

# Decontamination Approaches during Outages in Nuclear Power Plants — Experiences and Lessons Learned



**IAEA**

International Atomic Energy Agency

DECONTAMINATION  
APPROACHES DURING OUTAGES  
IN NUCLEAR POWER PLANTS —  
EXPERIENCES AND LESSONS LEARNED

The following States are Members of the International Atomic Energy Agency:

AFGHANISTAN	GEORGIA	OMAN
ALBANIA	GERMANY	PAKISTAN
ALGERIA	GHANA	PALAU
ANGOLA	GREECE	PANAMA
ANTIGUA AND BARBUDA	GRENADA	PAPUA NEW GUINEA
ARGENTINA	GUATEMALA	PARAGUAY
ARMENIA	GUYANA	PERU
AUSTRALIA	HAITI	PHILIPPINES
AUSTRIA	HOLY SEE	POLAND
AZERBAIJAN	HONDURAS	PORTUGAL
BAHAMAS	HUNGARY	QATAR
BAHRAIN	ICELAND	REPUBLIC OF MOLDOVA
BANGLADESH	INDIA	ROMANIA
BARBADOS	INDONESIA	RUSSIAN FEDERATION
BELARUS	IRAN, ISLAMIC REPUBLIC OF	RWANDA
BELGIUM	IRAQ	SAINT LUCIA
BELIZE	IRELAND	SAINT VINCENT AND THE GRENADINES
BENIN	ISRAEL	SAN MARINO
BOLIVIA, PLURINATIONAL STATE OF	ITALY	SAUDI ARABIA
BOSNIA AND HERZEGOVINA	JAMAICA	SENEGAL
BOTSWANA	JAPAN	SERBIA
BRAZIL	JORDAN	SEYCHELLES
BRUNEI DARUSSALAM	KAZAKHSTAN	SIERRA LEONE
BULGARIA	KENYA	SINGAPORE
BURKINA FASO	KOREA, REPUBLIC OF	SLOVAKIA
BURUNDI	KUWAIT	SLOVENIA
CAMBODIA	KYRGYZSTAN	SOUTH AFRICA
CAMEROON	LAO PEOPLE'S DEMOCRATIC REPUBLIC	SPAIN
CANADA	LATVIA	SRI LANKA
CENTRAL AFRICAN REPUBLIC	LEBANON	SUDAN
CHAD	LESOTHO	SWEDEN
CHILE	LIBERIA	SWITZERLAND
CHINA	LIBYA	SYRIAN ARAB REPUBLIC
COLOMBIA	LIECHTENSTEIN	TAJIKISTAN
COMOROS	LITHUANIA	THAILAND
CONGO	LUXEMBOURG	TOGO
COSTA RICA	MADAGASCAR	TRINIDAD AND TOBAGO
CÔTE D'IVOIRE	MALAWI	TUNISIA
CROATIA	MALAYSIA	TURKEY
CUBA	MALI	TURKMENISTAN
CYPRUS	MALTA	UGANDA
CZECH REPUBLIC	MARSHALL ISLANDS	UKRAINE
DEMOCRATIC REPUBLIC OF THE CONGO	MAURITANIA	UNITED ARAB EMIRATES
DENMARK	MAURITIUS	UNITED KINGDOM OF GREAT BRITAIN AND NORTHERN IRELAND
DJIBOUTI	MEXICO	UNITED REPUBLIC OF TANZANIA
DOMINICA	MONACO	UNITED STATES OF AMERICA
DOMINICAN REPUBLIC	MONGOLIA	URUGUAY
ECUADOR	MONTENEGRO	UZBEKISTAN
EGYPT	MOROCCO	VANUATU
EL SALVADOR	MOZAMBIQUE	VENEZUELA, BOLIVARIAN REPUBLIC OF
ERITREA	MYANMAR	VIET NAM
ESTONIA	NAMIBIA	YEMEN
ESWATINI	NEPAL	ZAMBIA
ETHIOPIA	NETHERLANDS	ZIMBABWE
FIJI	NEW ZEALAND	
FINLAND	NICARAGUA	
FRANCE	NIGER	
GABON	NIGERIA	
	NORTH MACEDONIA	
	NORWAY	

The Agency's Statute was approved on 23 October 1956 by the Conference on the Statute of the IAEA held at United Nations Headquarters, New York; it entered into force on 29 July 1957. The Headquarters of the Agency are situated in Vienna. Its principal objective is "to accelerate and enlarge the contribution of atomic energy to peace, health and prosperity throughout the world".

IAEA-TECDOC-1946

DECONTAMINATION  
APPROACHES DURING OUTAGES  
IN NUCLEAR POWER PLANTS —  
EXPERIENCES AND LESSONS LEARNED

INTERNATIONAL ATOMIC ENERGY AGENCY  
VIENNA, 2021

## COPYRIGHT NOTICE

All IAEA scientific and technical publications are protected by the terms of the Universal Copyright Convention as adopted in 1952 (Berne) and as revised in 1972 (Paris). The copyright has since been extended by the World Intellectual Property Organization (Geneva) to include electronic and virtual intellectual property. Permission to use whole or parts of texts contained in IAEA publications in printed or electronic form must be obtained and is usually subject to royalty agreements. Proposals for non-commercial reproductions and translations are welcomed and considered on a case-by-case basis. Enquiries should be addressed to the IAEA Publishing Section at:

Marketing and Sales Unit, Publishing Section  
International Atomic Energy Agency  
Vienna International Centre  
PO Box 100  
1400 Vienna, Austria  
fax: +43 1 26007 22529  
tel.: +43 1 2600 22417  
email: [sales.publications@iaea.org](mailto:sales.publications@iaea.org)  
[www.iaea.org/publications](http://www.iaea.org/publications)

For further information on this publication, please contact:

Nuclear Power Engineering Section  
International Atomic Energy Agency  
Vienna International Centre  
PO Box 100  
1400 Vienna, Austria  
Email: [Official.Mail@iaea.org](mailto:Official.Mail@iaea.org)

© IAEA, 2021  
Printed by the IAEA in Austria  
March 2021

### IAEA Library Cataloguing in Publication Data

Names: International Atomic Energy Agency.  
Title: Decontamination approaches during outages in nuclear power plants : experiences and lessons learned / International Atomic Energy Agency.  
Description: Vienna : International Atomic Energy Agency, 2021. | Series: IAEA TECDOC series, ISSN 1011-4289 ; no. 1946 | Includes bibliographical references.  
Identifiers: IAEAL 21-01388 | ISBN 978-92-0-101121-3 (paperback : alk. paper) | ISBN 978-92-0-101021-6 (pdf)  
Subjects: LCSH: Nuclear power plants — Safety measures. | Radioactive decontamination. | Decontamination. | Radiation — Safety measures.

## FOREWORD

After more than four decades of major decontamination activities during outages in nuclear power plants all over the world, decontamination technologies, tools and methods have advanced considerably. They have also benefited from parallel development in other industrial fields such as the chemical industry, electronics, robotics and computing. Decontamination plays an important role in keeping nuclear power plants competitive and safe, allowing long term operation.

This publication provides information on lessons learned and good practices for decontamination during outages in nuclear power plants. It addresses relevant aspects of decontamination in existing nuclear power plants with respect to radiation protection principles and outage planning.

The publication was produced by a committee of international experts and advisors from numerous Member States. The IAEA wishes to acknowledge the valuable assistance provided by the contributors and reviewers listed at the end of the publication. The IAEA officers responsible for this publication were H. Delabre of the Division of Nuclear Power and W. Meyer of the Division of Nuclear Fuel Cycle and Waste Technology.

#### *EDITORIAL NOTE*

*This publication has been prepared from the original material as submitted by the contributors and has not been edited by the editorial staff of the IAEA. The views expressed remain the responsibility of the contributors and do not necessarily represent the views of the IAEA or its Member States.*

*Neither the IAEA nor its Member States assume any responsibility for consequences which may arise from the use of this publication. This publication does not address questions of responsibility, legal or otherwise, for acts or omissions on the part of any person.*

*The use of particular designations of countries or territories does not imply any judgement by the publisher, the IAEA, as to the legal status of such countries or territories, of their authorities and institutions or of the delimitation of their boundaries.*

*The mention of names of specific companies or products (whether or not indicated as registered) does not imply any intention to infringe proprietary rights, nor should it be construed as an endorsement or recommendation on the part of the IAEA.*

*The authors are responsible for having obtained the necessary permission for the IAEA to reproduce, translate or use material from sources already protected by copyrights.*

*The IAEA has no responsibility for the persistence or accuracy of URLs for external or third party Internet web sites referred to in this publication and does not guarantee that any content on such web sites is, or will remain, accurate or appropriate.*

## CONTENTS

1.	INTRODUCTION .....	1
1.1.	Background.....	1
1.2.	Objective.....	1
1.3.	Scope .....	1
1.4.	Structure.....	2
2.	FUNDAMENTALS OF DECONTAMINATION DURING OUTAGES IN NPPS .....	2
2.1.	Definition.....	2
2.2.	Objectives and benefits.....	3
2.3.	Needs of decontamination .....	3
2.4.	Contamination mechanisms.....	4
2.5.	Main decontamination activities during an NPP outage .....	5
2.6.	Routine vs non-routine decontamination.....	5
3.	GENERAL CONSIDERATIONS FOR DECONTAMINATION.....	6
3.1.	Legal and regulatory considerations .....	7
3.2.	National vs local considerations .....	10
3.3.	Economic considerations .....	12
3.4.	Material considerations.....	12
3.5.	Radiation protection considerations .....	13
3.6.	Industrial safety considerations .....	14
3.7.	Outage planning considerations.....	15
3.7.1.	Long-term planning .....	15
3.7.2.	Short-term planning.....	16
3.7.3.	Critical path .....	16
3.8.	Technical considerations .....	16
4.	PREPARATION OF DECONTAMINATION .....	18
4.1.	ALARA approach.....	18
4.2.	Radiation data collection, evaluation and sharing .....	19
4.3.	Financial and human resources.....	19
4.4.	Training .....	20
4.5.	Procedures .....	21
4.6.	Logistics.....	23
4.7.	Contractors and suppliers .....	25
5.	TECHNIQUES OF DECONTAMINATION.....	27
5.1.	Decontamination of circuits.....	27
5.2.	Decontamination of pool cavities .....	28
5.3.	Decontamination of tanks and sumps .....	28
5.4.	Decontamination of concrete.....	28
5.5.	Decontamination of other equipments and materials .....	29
5.6.	Examples of decontamination methods.....	29



5.6.1.	Water wash .....	30
5.6.2.	Foams and gels .....	30
5.6.3.	Electrochemical decontamination .....	30
5.6.4.	Abrasive blast .....	31
5.6.5.	Dry ice blasting.....	31
5.6.6.	Strippable coatings .....	32
6.	ACHIEVEMENT OF DECONTAMINATION .....	32
6.1.	Key factors for a successful decontamination .....	32
6.1.1.	Preparation and realization .....	32
6.1.2.	Work and project management.....	32
6.1.3.	Cross departmental consideration.....	33
6.2.	Decontamination factor .....	33
6.2.1.	Definition.....	33
6.2.2.	Parameters affecting the decontamination factor .....	35
6.3.	Mitigation of recontamination and contamination buildup during decontamination procedure.....	36
6.4.	Knowledge management .....	38
7.	MANAGEMENT OF WASTE GENERATED DURING DECONTAMINATION.....	39
7.1.	Context.....	39
7.2.	Waste minimization .....	39
7.3.	Liquid waste .....	41
7.3.1.	Filtration .....	41
7.3.2.	Ion exchange.....	42
7.3.3.	Evaporation.....	43
7.3.4.	Sludge processing.....	44
7.3.5.	Precipitation.....	44
7.3.6.	Tritium removal.....	44
7.3.7.	Membrane processes .....	45
7.4.	Solid waste.....	45
7.4.1.	Incineration.....	46
7.4.2.	Compaction.....	47
8.	CONCLUSIONS .....	47
	REFERENCES.....	51
	ANNEX I.    INTERNATIONAL CASE STUDIES.....	55
	GLOSSARY.....	79
	LIST OF ABBREVIATIONS .....	83
	CONTRIBUTORS TO DRAFTING AND REVIEW .....	85

# 1. INTRODUCTION

## 1.1. BACKGROUND

Nuclear energy, as the largest low-carbon source of electricity, is vital to a clean energy future but it is threatened because it is facing challenging economic situation as well as public trust concerns. To cope these economic challenges and to regain public trust, technical, safety related, organizational and managerial aspects have been improved in the recent years in the nuclear power plants (NPPs). Decontamination is one of the technical aspects.

The IAEA has responded in the past to the needs of its Member States (MS) in the area of decontamination by producing various publications and supporting research programmes. However, it seemed necessary and appropriate to the IAEA to develop a new publication on decontamination of NPPs with the aim to update and review the needs, challenges and solutions in MSs.

As there are no dedicated IAEA publications on decontamination during outages, although it is frequently mentioned in sub-sections of publications, this new publication aims at addressing the key areas of decontamination during outages in NPPs. The goal is to provide state of the art guidance to Member States to select decontamination techniques suitable for their specific needs.

## 1.2. OBJECTIVE

The objective of this publication is to consolidate, update, reorganize and expand upon information contained in other IAEA NE publications related to the subject.

It describes experiences, good practices and lessons learned to address key areas of decontamination in NPPs during O&M, in particular during outages.

The information provided here represents experts' opinion and does not constitute recommendations made based on a consensus of Member States.

## 1.3. SCOPE

The publication describes, and provides guidance on various methodologies, tools, practices and approaches to carry out efficient decontamination during outage in NPPs in operation.

Even though if decontamination for newly build NPP reactors and decontamination during decommissioning are mentioned, this publication focusses mainly on NPPs in operation and for planned outages.

This publication is primarily intended for users from:

- Member States (MSs) with an operating NPP;
- MSs that are either building an NPP or are in an advanced planning phase for construction of a plant;
- International organizations involved in the development and/or promotion of nuclear energy;

- Governmental organizations in charge of nuclear energy or applications, including regulators;
- NPPs operating organizations wishing to improve their approaches for decontamination;
- Technical support organizations working in nuclear;
- Other entities involved in the nuclear industry sector (suppliers or contractors to nuclear power plants, e.g. NPP vendors, waste managers, technical support organizations, developers and suppliers of operating NPPs);
- Internal and external parties involved in the establishment, implementation, assessment and improvement of decontamination processes or activities.

#### 1.4. STRUCTURE

The main body of this publication is divided into eight sections including the introduction in Section 1 and the conclusions in Section 8.

An overview of the fundamentals of nuclear decontamination during outages in nuclear power plants is provided in section 2.

Section 3 lists the general considerations for decontamination.

The preparation of decontamination activities is described in section 4.

Section 5 shows various techniques of decontamination.

The achievements of decontamination are developed in section 6.

Treatment of waste coming from decontamination activities is discussed in section 7.

Finally, the IAEA-TECDOC is complemented by references, annexes providing relevant international case studies and experiences on specific aspects of nuclear decontamination, glossary and abbreviations.

## **2. FUNDAMENTALS OF DECONTAMINATION DURING OUTAGES IN NPPS**

### 2.1. DEFINITION

According to IAEA definition (see glossary at the end of the publication), decontamination is ‘the complete or partial removal of contamination by a deliberate physical, chemical or biological process’.

This definition is intended to include a wide range of processes for removing contamination from people, equipment and buildings, but excludes the removal of radionuclides from within the human body or the removal of radionuclides by natural weathering or migration processes, which are not considered to be decontamination. For the purposes of this publication, only surface decontamination of structures, systems and components (SSC) is considered.

Most processes described in this publication refer to chemical decontamination, as non-chemical processes are more pertinent to NPP decommissioning than to NPP outage for maintenance or refuelling, which is the focus of this publication. Several decontamination techniques described in this publication are not specific to outages, but they can be conveniently applied during outages, should such a need arises.

## 2.2. OBJECTIVES AND BENEFITS

The general objectives and benefits of NPP decontamination may include some or all the following:

- Reduce occupational exposure to the workforce e.g.:
  - For lowering dose rates or contamination of SSCs to allow personnel access and/or work in contaminated areas of the NPP;
  - For reducing requirements for shielding;
  - For reducing requirements for respiratory protection (especially for alpha contaminated SSC);
- Reduce the residual radiation source at the site to minimize any potential hazard to public health and safety in preparation for safe storage (more pertinent to decommissioning);
- To down-grade waste category of contaminated material (e.g. from high-level- to low-level waste (LLW) or from LLW to exempt waste (more pertinent to decommissioning));
- Reduce the volume of equipment and materials requiring disposal in licensed repositories (more pertinent to decommissioning);
- Concentrate radioactive material for placement in a permanent storage/disposal container (more pertinent to decommissioning);
- Restore the site and facility, or parts thereof, to an unrestricted use condition (more pertinent to decommissioning);
- Salvage equipment and materials (more pertinent to decommissioning);
- Reduce the overall cost of the nuclear project.

The reader can note that certain decontamination activities are more pertinent to decommissioning (as highlighted above) than to outages because of the large volumes of materials/wastes generated but may take place during outages as well.

## 2.3. NEEDS OF DECONTAMINATION

Decontamination planning commences with a recognized need. In general, decontamination will be less expensive and radiological exposure limited if the need is ascertained and planned for during the reactor design phase. In the early phase, structural features intended for decontamination as sampling points, materials compatible with added chemicals, injection of (e.g. zinc injection as a way of reducing contamination build-up) and draining lines, and sufficient waste tankage, can be easily incorporated into the reactor construction. Dedicated construction features can be installed at the construction stage to facilitate the planning and implementation of decontamination activities. Features could be designed for the decontamination of the entire conception of the plant or can be specifically aimed at full-system decontamination (FSD). Besides, if these features are included in the initial design, it will be less expensive to refurbish or upgrade –if the need occurs- than to install features during operation. Decontamination is typically covered in the reactor safety analysis report and related technical specifications that are promulgated as part of the license.

In some reactors, however, the need to decontaminate does not come to the attention of the operating organization for years of reactor operation until increased dose rates jeopardize the

required implementation of operations. The need for decontamination may then stem from consideration of collective exposures, from an expected impact on individual exposure limits, or from an anticipated shortage of qualified staff. These concerns have been the main reasons for the repeated decontaminations of CANDU plants in Canada, but relatively less important at some existing NPPs in the U.S.A. In the USA, decontamination is performed to facilitate inspections in high radiation field environments, during the imperative need for major maintenance of certain component or following accidents. The value of the decontamination is also tied to the overall dose performance of the utility. If the utility rank lower on the dose performance scale as compared to other plants, then a higher priority is typically given to perform a decontamination for general dose reduction.

Decontamination for maintenance is more likely to target a single component or a part of a system. Decontamination of a large component, e.g. a steam generator is generally easier than full-system decontamination because of shorter duration and less waste generated. The simplest decontaminations are those employing only fluids that are harmless to the system, such as water, or boric acid. Mechanical decontamination methods are generally more harmful and typically used when preservation of system properties is a lesser concern (e.g. in decommissioning).

During decontamination of NPP during outages, a dilute liquid process, in which radionuclides are absorbed from the decontamination chemicals onto ion-exchange resins, is expected to require minimal waste management. With such dilute processes a decontamination factor (DF) up to average 5-10 on full reactor systems is expected. Should fuel be present during decontamination, fuel warranties may be required with a specific agreement with the fuel supplier. A higher DF can be achieved using concentrated solutions, but this approach, in addition to being validated for material compatibility, may require prior removal of the fuel and evaporation of decontamination solutions prior to immobilization.

## 2.4. CONTAMINATION MECHANISMS

The rate of occurrence and growth of contamination levels during the NPPs operation and the subsequent request for decontamination depend on a wide range of parameters.

The main factors affecting origin, type and amount of contamination are:

- Type of reactor (e.g. PWR, WWER, BWR, PHWR, RBMK, FBR, AGR);
- Construction material with a focus to the content of the alloying elements which, after activation, significantly increase the dose rate levels (e.g. cobalt-rich materials such as stellite);
- Operating configuration e.g. number of the main components (circulation loops, circulation pumps, steam generators);
- Properties of the inner surfaces exposed to the coolant. It is known that surface roughness, type of the oxide films on the surfaces and oxide film thickness affect how much the films can incorporate activity;
- Method of surface passivation before the NPP commissioning (during the hot functional tests);
- Type of fuel (natural U, enriched U, Th and mixed oxide fuel) and its quality (cladding resistance to leakage);
- Type of coolant and moderator (gas, water, boric acid solution, liquid metal and heavy water);
- Thermodynamic and hydraulic parameters;
- Chemical redox (pH) regime;

- Refuelling period (periodical vs continuous);
- Electric power generation (operation history, load factors and power uprate);
- Major failures of technological components (including fuel damage);
- Leaks from radioactive to non-radioactive systems;
- Number of forced shutdowns;
- Accomplished modification;
- Large components replacement (SG, heat exchangers);
- Full system decontaminations (scope and periodicity);
- Types and capacities of gas purification systems and water treatment and purification systems.

## 2.5. MAIN DECONTAMINATION ACTIVITIES DURING AN NPP OUTAGE

The main decontamination activities performed during outage for maintenance or refuelling at NPPs may comprise one or more of the following:

- Removal (decontamination of un-fixed surface contamination (dust, particles, grease, puddles)
- Decontamination of metallic surfaces prior to material testing;
- Decontamination of SSCs contaminated during operation;
- Decontamination of removable or fixed parts of equipment repaired and/or maintained during outage;
- Decontamination of large components or areas (tanks, cavities, extensive technology systems, spent fuel pools) used for maintenance and/or refuelling activities;
- Full system decontamination (FSD) if needed;
- Decontamination of the spent fuel storage casks and components of refuelling machines.

A special case is the removal of deposits containing radionuclides from the surface of non-radioactive base materials (e.g. the secondary side of steam generators), which is often referred to as chemical cleaning.

## 2.6. ROUTINE VS NON-ROUTINE DECONTAMINATION

Routine decontamination activities could be defined as those activities occurring repeatedly during a plant lifetime due to refuelling, maintenance and or inspection requirements of the NPP. Examples could be decontamination of reactor coolant pumps and other primary pumps, heat exchangers, valves, tanks, pressure vessels, primary instrumentation, etc. The scope of the decontamination work is well known and understood. This activity could be performed by the NPP staff, or be sub-contracted, for example, to entities performing maintenance activities, or other specialized decontamination vendors.

Non-routine decontamination activities could be defined as those occurring infrequently during a plant lifetime as a specific intervention, for example for system dose reduction/plant life extension (sub-systems/systems/FSD) needing specific planning, engineering changes, equipment replacement and alternative application processes. Such activities are typically performed by a specialized vendor/sub-contractor using a proprietary chemical decontamination process.

The available decontamination systems at different NPPs varies from some rudimentary equipment to well-equipped decontamination workshops. This is a result of the NPP design, technical specifications, national legislation, regulatory body requirements, funding etc.

### 3. GENERAL CONSIDERATIONS FOR DECONTAMINATION

Decontamination is not necessary in all cases. In fact, the real questions to be asked are presented in Figure 1.

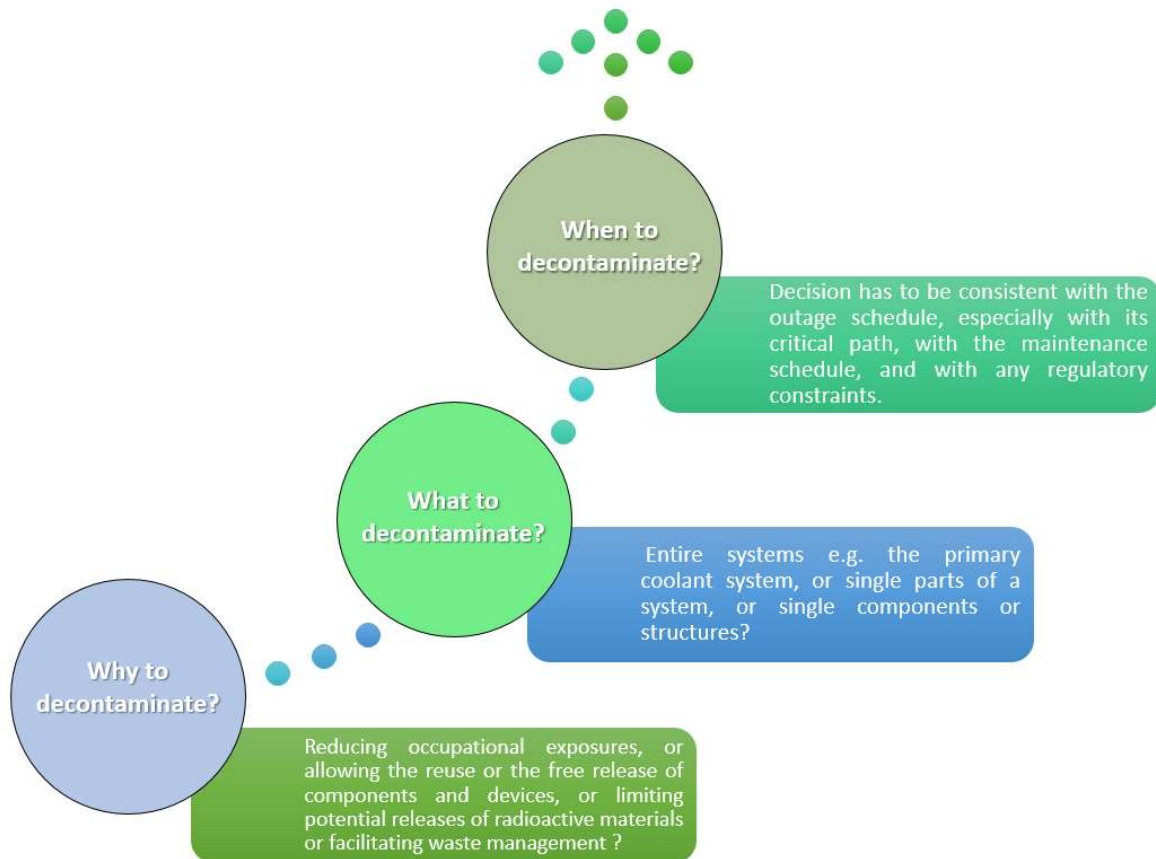

FIG. 1. General considerations for decontamination.

The decision to decontaminate during outages depends upon several factors. A factor that summarizes most of them is: does the benefit in operational performance or occupational exposures justify the cost, and environmental impacts? This determination can be realized through a cost-benefit analysis, in which the present value of benefits is compared –ideally using the same units- with the present value of costs. If the benefits exceed the costs, decontamination is justified and in principle has to be performed, unless overwhelming factors impede it.

Benefits may be achieved either in reduced financial cost or in reduced occupational exposure. In general, decontamination may be performed at some cost to reduce exposures. However, if a unit becomes inoperable because it is too highly contaminated, it can either be decontaminated or it can remain shut down.

Before initializing decontamination activities, alternatives have to be investigated and compared. For example, dose rates may be lowered by placing shielding over high-level sources. Remote monitoring or simplified inspection procedures may reduce the requirements for manned access. In some cases, natural decay may reduce the need for or postpone decontamination. In the USA most BWRs have employed both zinc injection and noble metal chemical addition to delay decontamination as:

- Zn reduces incorporation of activity into films and slows down the diffusion of Co from base metal to solution hence reducing the source term;
- Noble metal addition is used to reduce the amount of hydrogen to reduce the  $^{16}\text{N}$  levels in steam lines and at the same time ensuring that intergranular stress corrosion cracking (IGSCC) and irradiation assisted stress corrosion (IASCC) is mitigated

With these chemistry additions, these BWR units are experiencing reducing dose rates over time due to lower cobalt incorporation into base metals. If none of these alternatives are feasible, or other concerns remain, then decontamination may be required.

### 3.1. LEGAL AND REGULATORY CONSIDERATIONS

Depending on national legislations decontamination operations might require licensing. Typically, the approach required depends on whether the decontamination campaign is a routine activity or is a first-of-its-kind event (new technologies, new systems being decontaminated etc.) or is a rare event for this NPP. Another regulatory criterion is the size/extent of the process: if limited to one small component, a large component (e.g. a steam generator) or an entire system like FSD (see annexes). In many Member States, if planned decontamination projects do not require either modifications to technical specifications or raise an unresolved safety concern, decontamination can be carried out without specific regulatory approvals. Within these constraints preparatory activities during reactor operation are legally allowable without regulatory involvement.

Should a licensing process be needed this could include a formal approved safety assessment or it can be limited to reviewing the documentation submitted or made available by the licensee, or even be limited to regulatory in-the-field supervision or inspection. In some Member States the regulatory assessment includes even the review of work procedures.

A decontamination campaign can be reviewed by multiple regulators, e.g. the nuclear regulators and those entities responsible for industrial hazards (e.g. safe work Australia, Canadian Centre for Occupational Health and Safety, Occupational Safety and Health Administration (OSHA) in the USA etc.). These multiple interactions require coordination of roles and responsibilities. As one example, a specific authorization can be needed for the storage of hazardous materials (e.g. chemicals) intended for decontamination.

Regulators can also exert different roles in regard to decontamination contractors: in some Member States, regulators want to check the certifications, qualifications, experience/expertise and/or training of contractors, and may provide a specific authorization for their work; in others, the regulators will content themselves with ensuring that the operator (licensee) has provisions in place, e.g. a quality management (QM) programme to ascertain that its contractors can do the job safely.

Regulators may grant approval to a decontamination activity as a single campaign, or in phases, subject to the successful completion of a preceding phase: for example, laboratory validation



testing, followed by pilot plant operations, or decontamination of a small section of a circuit, before final approval for implementing the decontamination process.

In general, regulators will not take a prescriptive position forcing the operator to decontaminate components or systems, but they may view decontamination as implementing the ALARA principle 'as low as reasonably achievable'. For example, regulators may require the lowering of occupational doses during outages- based on past experience- when too high or not compliant with the ALARA principle based on past experience. This requirement may in turn result in the operator planning for and implementing decontamination, but it may alternatively result in other actions e.g. shielding dose-critical components or reducing the duration of certain outage operations.

In some Member States, regulators may review, license or certify a decontamination process regardless of the specific NPP under consideration. Regulators may also assume that the license or certification given to the process in another country is also sufficient for their own purposes. However, regulators who have already approved the decontamination process will review other specific content as well (i.e. the NPP components or systems in questions, the plant layout, contamination levels, organization and management measures etc.). In other Member States yet, the regulators will not approve the total decontamination project per se, but only a specified procedure within the decontamination project.

Prior to any detailed safety assessment, it is possible that the operator will be required to justify to the regulator(s) the rationale for the extent and strategy of the outage decontamination programme selected. Depending on national legislation, the operator may have to submit this justification before preparing other documents for detailed review.

It can be noted that not all national regulators are participating in the decision-making process as they may consider that it is the operator's prerogative and may be more interested in evaluating whether the proposed action (in this case, decontamination) is safe enough.

By contrast, in the UK the concept called Best Practicable Environmental Option (BPEO) is widely used, including for regulatory assessment. The aim of a BPEO study is to ensure that the rationale behind a strategic decision, involving technical, scientific and more qualitative judgements, e.g. consistency with the overarching principles of precautionary action and sustainable development, is made visible. A BPEO study may be required to direct the operator's or the regulator's decision-making; however, it is seldom the sole criterion for the choice. One example of BPEO as applied to waste management is given in the publication Ref. [1] related to the restoration of the Dounreay site.

To justify the need for outage decontamination, it is likely that the nuclear regulators' attention will address the radiation exposure aspects rather than any financial benefits generated by the decontamination programme. In this cost-benefit analysis, monetary values are assigned to the man-sievert spent or averted by the decontamination. These values are also used for ALARA assessment of the process.

In general, there are two types of values for the man-sievert:

- Those recommended by some national regulators, such as in Canada, Czech Republic, the Netherlands, Sweden, Switzerland, the United Kingdom and the United States;
- Those used as a planning tool at most nuclear facilities worldwide.

The values recommended by the regulatory bodies generally range around tens or a few hundreds of US \$ per man.mSv, while the facilities' managerial values are one order of

magnitude higher: they often range between one thousand and three thousand US \$ per man.mSv.

For this assessment, the following three exposure scenarios are typically compared:

- Continued reactor operation (occupational exposures with no decontamination can be estimated from exposure records);
- Exposure during decontamination (this can be estimated based on current NPP state and the state expected during all decontamination tasks, including waste management);
- NPP operation after decontamination (this exposure can be estimated using the expected DFs for the SSC affected, the number of workers used in each area, and the duration of work. This assessment will also have to consider the rate of radiation build-up during the NPP operation following decontamination).

It can be noted that factors inherent to a decision on if and how to decontaminate are of different nature and are expressed in different units (e.g. the DFs, the waste generation in m<sup>3</sup>, the monetary costs, occupational exposures in man.mSv) but there are also factors that are not easily quantifiable (e.g. probability of success, stakeholders' views, industrial safety, skills required). While some factors are safety-related, others aim at the costs of decontamination itself and its financial benefits to the NPP operation. An example of a formal decision aiding technique is multi-attribute analysis (MAA), a decision-making tool for comparing alternatives in decision making about complex alternatives, in our case for identifying and quantifying the impact of each decontamination alternative (including no decontamination).

A general description of MAA is given in Ref. [2] on decontamination-related applications. MAA models allow assign values to alternative choices (e.g. concentrate vs dilute solutions; or different concentrations of a given chemical agent) and the proposal with the highest value will be considered. MAA models could be used to investigate the consequences of different options. The models assume that the apparent desirability of one specific alternative depends on how its attributes are viewed by each evaluation team member. To use MAA, one first identifies all the attributes needed to fully assess the alternatives. The attributes are each given a weight that reflects their significance to the evaluation team member. One then gives a score to each of the alternatives for each attribute. Each alternative's score for each attribute is then multiplied by the weight of that attribute, and the total is calculated. That total represents the value (or utility) of that alternative and can be compared to the values estimated for the other alternatives.

However, selection of decontamination techniques by considering incompatible factors imply that the outcome of certain aspects could be judgmental and subjective. The operating organization has to ensure that all stakeholders are represented in the decision-making team (e.g. plant departments such as operations planning, health physics, waste management, chemistry) with the objective of reaching a mutually acceptable outcome. Either the cost-benefit analysis or MAA have not to be viewed as absolute arbiters of the decision-making: rather these techniques allow assist expert judgement.

It has to be clear to those performing cost-benefit analyses or MAA that safety is the predominant factor: in no case has safety to be impaired by the result of such optimization analyses. Some Member States have no specified \$ value for the man-sievert and uses cost-benefit on a case-by-case qualitative mode. Additionally, certain safety approaches (e.g. waste minimization) can be controversial in Member States where waste disposal is available and cost effective.

Regardless of the regulatory review being generic or plant-specific, the detailed safety assessment (if one is requested) is likely to address at least the following safety concerns in large-scale decontamination (more detail is given in section 3):

- Need of decontamination;
- Scheduled date and programme for decontamination;
- Scheduled date for reactor restart after completion of decontamination;
- Specific system, structure, component to be decontaminated;
- Changes to the licence or to the technical specifications required after decontamination or following restart;
- Key decontamination considerations, e.g., the decontamination process proposed, the rationale for the proposed process, compatibility of system materials and decontamination agents etc.;
- The impact of any external event or system malfunctions may have on the smooth operation of decontamination activities; interactions with plant safety systems resulting from such events will be considered;
- Organization managing the decontamination;
- Estimation and management of anticipated radioactive and hazardous chemical waste amounts (solid, liquid, and airborne);
- Environmental impact assessment of the proposed decontamination;
- Contingency and emergency provisions;
- Interactions with other existing protection functions or other systems;
- Plans for tests, inspections, and recertification of SSC prior to resumption of operation;
- Fluid systems (e.g. anti-leakage barriers, fracture prevention, prevention of criticality);
- Overall requirements (e.g. protection against environmental agents, sabotage or fire protection);
- Records.

Many of the above-mentioned issues may be assembled for regulatory review into dedicated documents such as the health and safety programme, the waste management programme, or the QM programme of the decontamination campaign.

The overarching IAEA references for licensing and safety assessment can be found in references [3–6].

As an example of relevant national regulations, those promulgated in Finland are given in Annex I-5.

### 3.2. NATIONAL VS LOCAL CONSIDERATIONS

The level at which decisions about decontamination are taken depends on the local context: number of NPPs, nuclear programmes and infrastructure, ownership of the plants, etc.

Typical elements of a decontamination strategy are described in Figure 2.

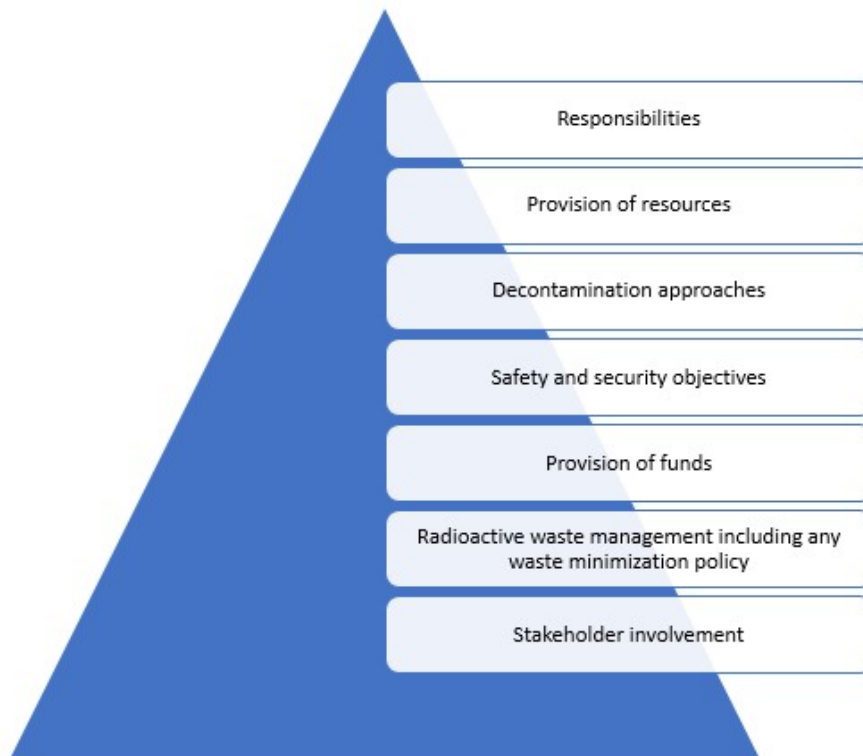

*FIG. 2. Typical elements of a decontamination strategy*

The strategy elaborates the objectives and requirements established in the policy.

Decontamination policy and strategy can be established at national, corporate or local (NPP site) level. The technical options decided upon for a project by the implementers will reflect priorities and requirements as mentioned in the decontamination policy and strategy document and also consider the impact of decontamination on the local workforce as well as the views of the stakeholders if relevant to the project in question. The following circumstances exemplify variations in radioactive waste (RAW) management following decontamination.

In a Member State with many NPPs under a common ownership (e.g. in France) there is a national policy and infrastructure covering most decontamination aspects e.g. a waste minimization policy, low-level waste (LLW) and very low-level waste (VLLW) disposal sites, a nation-wide regulatory system, a number of decontamination companies experienced in nuclear decontamination and active Research & Development (R&D) programmes. Within the mandatory boundaries of this infrastructure and an allocated budget, the operator of a given NPP will decide on the technical factors related to plant-specific features, such as dealing with materials, layout, radiation and contamination levels, and on renovation of the site infrastructure and re-configuration of the site for decontamination purposes.

There are also Member States (e.g. the USA) where national infrastructures and resources are widely available, but there is no national policy established for aspects relevant to decontamination e.g. on waste minimization: these decisions are taken at the utility corporate level, typically based on financial considerations (with the NPP organization being responsible for technical implementation depending on plant-specific features and the local market). It is therefore possible that within the same country, depending on availability and costs of using a waste disposal facility, one NPP pursue an aggressive programme of waste minimization, whereas another tends to produce and ship waste offsite within a minimum programme of waste minimization e.g. volume reduction.

The case of a country with one or two NPPs and/or modest nuclear power programmes is different: it is unlikely that resources and infrastructure are centralized, which implies that many more decisions about decontamination are taken locally. This may include, among others, decisions about the establishment of onsite RAW management facilities and additional (possibly long-term) storage capacity for RAW generated by decontamination. The operator can then decide on how the waste minimization principle is interpreted (subject to regulatory review).

The recruitment of outage decontamination contractors is another area where decisions can be taken either at corporate or NPP level, depending on the overall national policy (or lack thereof). An IAEA publication –although not specific to outage decontamination- providing guidance on the role played and interactions by different organizations in the NPP industry is to be found under the IAEA publication Ref. [7].

### 3.3. ECONOMIC CONSIDERATIONS

The decision as to perform decontamination is dependent on many aspects such as regulatory body requirements, impact on dose to personnel, Member State's policies, laws and regulations, maintenance requirements, financial implications, etc. Before deciding on to perform decontamination activities, the operating organization needs to have a clear achievable objective (lower dose rate, lifetime extension, etc.) and the cost involved to achieve these objectives i.e. what will be the return on investment.

The decision for decontamination can be made instantaneously, for example, decontamination of reactor coolant pump (RCP) prior to maintenance or can be more complex in the case of an FSD in which the entire primary system is affected. In addition, the cost and the final impact of the dose reduction will be significantly different depending on the magnitude and duration of the intervention.

A simplified list of decontamination-related costs includes the following:

- Chemicals, consumables, mechanical support equipment (forklifts, trolleys, drums, etc.);
- Equipment design, set-up, maintenance, disassembly incl. robotics (if any);
- Labour, including any training required;
- Contractor supervision;
- Critical path impact;
- Development and adaptation of the process to the plant;
- Upgrade of existing plant utilities/services;
- Waste management.

### 3.4. MATERIAL CONSIDERATIONS

Regarding material compatibility, it is important that the chemicals are authorized for use in the NPP.

Chemical decontamination involves the use of either concentrated or dilute reagents. In general, both the concentrated and dilute processes fall into one of the following chemical classifications:

- High-pH oxidation followed by low-pH dissolution;

- Low-pH oxidation followed by low-pH dissolution;
- Low-pH dissolution;
- Low-pH reduction and dissolution.

An example of the “High-pH oxidation followed by low-pH dissolution” process is the use of alkaline permanganate (AP), which oxidises chromium activity absorbed onto the metal surfaces to form chromium oxide. This alkaline permanganate step is followed by using organic acid e.g. oxalic acid or mixtures of citric/oxalic acids to dissolve the formed chromium oxide (low-pH dissolution). In this case there might be some dissolution of chromium from the base metal in the first step, but the main objective of AP is to transform the corrosion product film to an oxide form to ensure absorption as a decontamination step when using dilute acid as second step. For plants with high antimony levels (more common in heavy water plants), only the AP step is performed to release the antimony into solution allowing it to be removed by the ion-exchange (IX) resins. These processes are generally applied to PWR systems, which operate under reducing conditions.

Decontamination chemicals could have an impact on the base material of the system and/or component. It is recommended to do material mapping of material (metal surfaces, joints, sealing and others) that could be exposed to decontamination chemicals, as well as identifying composite materials that could initiate galvanic corrosion during decontamination process. This will be done to mitigate and prevent any unexpected corrosion.

Effective decontamination processes have the potential to remove some of the base material under the oxide layer. In establishing acceptable corrosion rates (or removal rates), the main consideration is to assure that system components will not be damaged and continue working under design conditions (e.g. no more than a pre-established percentage of the design corrosion allowance is removed in a decontamination pass). Acceptable corrosion rates will not be identical for all components, and certain types of corrosion (e.g. pitting, crevice corrosion, stress corrosion cracking) are not admissible at all. Special attention needs to be paid to:

- Residual chemicals remaining in dead legs or crevices, which may cause excessive corrosion after reactor restart;
- Products (chemicals and decontamination solutions) that upon decomposing are incompatible with system materials or decompose very little and remain in the system for longer than recommended durations.

### 3.5. RADIATION PROTECTION CONSIDERATIONS

Typically, the main driver for any decontamination activity is to reduce the dose, either for a maintenance activity on a component, sub-system or system or for some other requirement (Regulatory body, lifetime extension, etc.). The resultant dose savings are directly related to what this driver is. For example, if maintenance was required on a contaminated heat exchanger it can be easily calculated what the dose to workers would be with or without decontamination even using conservative DF estimates. The same would apply for a more extensive decontamination such as an FSD where the individual and collective dose savings impact would be far more significant in the long term.

Once again, prior to performing any decontamination activity, the objective is clearly defined and understood by all the involved parties.

Dose saving can be calculated based on the efficiency of the process implemented. The dose rate reduction from before to after decontamination (mSv/h) multiplied by the exposure time

(person-hours) for maintenance personnel after decontamination produces the collective dose saving. Following this approach, it is necessary to estimate the time that occurs before recontamination undoes the dose rate reduction.

Individual dose savings depend on the location and the radiological parameters of the contamination that can affect critically exposed workers (maintenance technicians, scaffolders, etc.).

The limits of acceptable radiation exposure for decontamination are the same as for other licensed operations and are given in IAEA Safety Standards Series No. GSR Part 3 [8]. However, changing dose rates and location during decontamination are a significant challenge in plan for minimal radiation exposure. Decontamination displaces the original radioactive inventory (influences local dose rates), mobilizes contamination and could result in possible airborne hazards.

Dead legs, valves, instruments, and sample lines are typical locations for radionuclide re-deposition. Decontamination planning includes early identification of these areas, and provisions are to be taken prior to decontamination to prevent the build-up of oxide film deposits or the dislodging of formed films. Preventative actions may include the removal of internal components from a valve (these being likely spots of re-deposition), installing flush lines on expected areas of stagnant flow, or injecting solutions through sample lines to flush these areas.

Prevention of radiological incidents or high doses to workers could also be done by shielding systems and/or components where possible increase in dose rate during decontamination is possible. Examples of systems and components to be shielded are ion exchangers, filters, heat exchangers, dead ends, etc.

Radiological re-classification of zones during or after decontamination can be required.

It is important to include RP/health physics in discussions before, during and after the decontamination period.

### 3.6. INDUSTRIAL SAFETY CONSIDERATIONS

Industrial safety is about the prevention of (non-radiological) physical damage to staff and to property. The main safety hazards include falling objects, slips and trips, cuts, and burns from chemicals or heating sources. These concerns are important considerations in planning. Certified industrial safety consultants may be recruited in support to the reactor staff.

Decontamination may require staff to enter areas that are not normally accessible. To minimize the risk of accidents in these areas, a mix of design features (e.g., railings, gangways), maintenance (e.g., lighting, equipment repair), training, and personnel protective equipment (e.g., respiratory protection, safety glasses, hard hats) is vital. Well managed maintenance, inspection, and testing of items such as cranes, hoists, and utilities that are used during decontamination can be critical to staff safety.

Planning for the housekeeping that will be needed before, during, and after decontamination is also important.

The selection and training of personnel with adequate strength, experience, and safety culture will minimize the probability of an accident. If individuals are assigned to do work (such as material handling or climbing) that they do not have enough skills for, the probability of an accident will increase.

Decontamination may also involve noise-related hazards and the potential for heat stress. Among other products, cooling vests are commercially available to reduce the risk of heat stress.

Fire requires combustible material, oxygen as well as a source of ignition (e.g. in decontamination a possible source could be from thermal cutting, welding, electrical and instrument wiring). A fire safety programme is primarily intended to remove all combustibles from the work zone, but a fire preparedness programme is yet needed to ensure that any occurring fire e.g. from brought-in material is quickly extinguished in situ. If the decontamination and waste management processes employ only aqueous solutions, there are no new facilities, and waste is immobilized in concrete, then fire protection cannot be a major concern.

Personnel safety is to be considered during the chemical selection. Example of parameters to evaluate could be available chemical/material safety data sheets, working staff protection, protection in case of fire, storage of chemicals and use of chemicals. The chemical/material safety data sheets include a lot of information regarding handling of the chemical. Reactor decontamination will commonly include the use of such hazardous chemicals as toxic, carcinogenic, mutagenic, explosive or causing developmental malformations.

The temperature of the fluids used for decontamination process could reached up to 100°C as part of the energy released by chemical reactions so this is also a safety-related parameter.

Plan and prevention for leaks of chemicals and decontamination fluids could be done in advance to discover a leakage or to mitigate its impact. For example, a start with heated demineralized water with no chemicals added could prevent or reduce the impact on personnel from chemicals should a leak be present before the actual operation.

The emergency preparedness required for decontamination operations is similar to that required for maintenance activities. To counteract the impacts of certain chemical decontaminants ad-hoc emergency showers, eyewash devices, and neutralizing chemicals may be required.

An IAEA publication, co-sponsored by the International Labour Office (ILO), provides guidance on industrial safety for nuclear activities: although not specific to nuclear decontamination, it can be usefully consulted for this purpose [9].

Industrial safety standards are provided by organizations such as Occupational Safety and Health Administration (OSHA) in the USA. One OSHA standard relevant to all aspects of this publication is given in Ref. [10].

### 3.7. OUTAGE PLANNING CONSIDERATIONS

#### 3.7.1. Long-term planning

The maintenance plans for outage, including requirements for decontamination, are prepared well in advance e.g. 9 to 12 months before planned outage start date. The decontamination requirements are based on the history of the reactor, previous collected data (i.e. during the previous outages/cycles/shutdowns) such as dose rates, chemical compositions, type of radionuclide and activity concentration.

A recommendation is to start planning for large scale decontamination at least one-two years before the decontamination takes place. FSD is recommended to be planned at least two years in advance. Small scale decontamination for example on a pump or a valve does not have to be planned years in advance. This could be done for example within the normal outage planning.



It is vital that the decision between effecting decontamination and other approaches not needing decontamination be taken in an early phase of planning. Decontamination generally incurs occupational doses, increases the non-radiological risk associated with the use of toxic products, generates airborne hazards, produces secondary waste, and weighs on the planning and the resources needed of facility's outage. Also, it has to be proved that sufficient expertise (in-house or contracted) is available to manage the decontamination process; and that the decontamination workers are correctly briefed and trained. Therefore, these issues have to be addressed in the decontamination file (i.e. decontamination plan, and supporting documents such as health and safety report, waste management plan and environmental impact assessment); depending on national legislation and other factors, this file may or may not be subject to regulatory review/approval.

### **3.7.2. Short-term planning**

The decontamination period for a larger scale decontamination including preparation, installation and provisioning is normally 20-60 days depending on decontamination scope. Plan and schedule include main activities mentioned in section 5. These main decontamination activities have to be submitted and integrated in the overall outage plans.

Normal time frame for large scale decontamination operation is around 6 to 14 days depending on the number of cycles. One cycle lasts approximately 1 to 2 days. Small scale decontamination could be done in much shorter time. It could be appropriate to have a back-up plan if something unexpected happens, for example when the DF achieved is not as high as required or expected.

### **3.7.3. Critical path**

Sometimes the duration of the decontamination process can be on the critical path of the outage. Decontamination normally will be adapted to the critical path but sometimes decontamination can affect the critical path. In this case, optimal decontamination planning and execution will help reduce critical path time. However, to stay within the time constraints of the outage plan has not to impair the safety of activities.

## **3.8. TECHNICAL CONSIDERATIONS**

Proven decontamination methods have to be considered as a first option. The time and other resources required to validate untested methods are not likely to be there during outage decontamination. If some adaptations or modifications to a standard decontamination technique are needed before implementation, the following major points to be considered are:

- Material to decontaminate and state of its surface (chemistry of oxide layers, roughness, irregularities, geometry etc.);
- Process effectiveness (local and average DF, material configuration, contamination (type, level), single-step vs multiple-step processes, cleaning rate);
- Operability/simplicity/reliability of the process (plant utilities available, operator training time, operators required, equipment set-up time, pre-conditioning, equipment clean-up time, time for decommissioning of decontamination tools/systems, flexibility);
- Remote applicability/robotics as needed;

- Required development (probability of success, test facilities, technology transfer, technological readiness);
- Licensing requirements (ease of environmental and safety compliance, compliance with existing permits / licences, safety documentation);
- Physical conditions and other industrial aspects of the environment (temperature, humidity, layout, access and egress, available space for all decontamination-related activities etc.);
- Compatibility of materials and solutions in both the system being decontaminated and waste storage tanks;
- System isolation requirements (blind flanges, containment tents);
- Post-decontamination component requirements (e.g. replacement of inner parts of a valve or pump, requalification of decontaminated system/component for reuse);
- Requirements for sampling and area surveys to monitor process performance during and after decontamination;
- Occupational exposure (pre-decontamination radiation survey, equipment installation and testing, chemical addition, decontamination operations, monitoring and surveys, decontamination system ultimate removal or modification);
- Industrial safety (material storage and handling, leakage, ingestion of toxic gases);
- QM;
- Waste management (primary and secondary waste).

In case of chemical decontamination, the following major points are also to be considered:

- Solution sensitivity to temperature and pressure variations (tolerance to variations without the solution decomposing or becoming inert);
- Solution purity requirements (corrosion due to impurities, solvent additions required to maintain concentration);
- System flushing requirements (number of passes and volume of wastes generated);
- Requirements for reconditioning decontaminated surfaces (passivation);
- Redistribution of contaminants (plate-out in 'dead legs', need of sequestrants to keep contamination in solution, occurrence/chances of 'hot spots');
- Some sub-systems such as fuel pool cooling and clean-up may have design temperature limitations that are less than typical chemical decontamination application temperatures (~90°C-95°C).

The main consideration, however, is the expected effectiveness of the process. Based on these considerations, one or more decontamination processes can be selected as likely candidates.

As an example, the EDF strategy is quoted. In a first approach, the means to implement the appropriate auxiliary circuit decontamination (mechanical and/or chemical processes) depends on out of flux circuit dose rate circuits and their radiochemical characterization (values obtained during outages, and time evolutions). To obtain good results in terms of dose rate reduction factors, it is essential to be sure that the source term at the origin of the over-contamination is stabilized before decontamination.

## 4. PREPARATION OF DECONTAMINATION

### 4.1. ALARA APPROACH

Decontamination is one of the possible steps to reduce radiological hazard in accordance with international, national, corporate and local policy and regulations. But, in parallel, adequate attention will be paid to the health and the safety of workers to protect them from radiological and non-radiological hazards associated with the decontamination itself.

Therefore, the principles of RP (see ICRP publication [11], EURATOM directive [12] and IAEA general safety guide [13]) have to be implemented at the stage of preparation of decontamination activities, but of course also during these activities.

As reminder, the three fundamental principles of RP are the following:

- Justification: any decision that alters the radiation exposure situation should be justified. It means that any exposure is only permitted when it is associated with a reasonable benefit. ‘Reasonable’ means that the benefit outweighs any possible harm to health;
- Optimization: even if a planned activity is justified, the likelihood of exposures, the number of exposed persons, and the magnitude of their individual doses should then be kept as low as reasonably achievable (so-called ‘ALARA principle’) taken into account the latest technical, economic and social factors;
- Dose limitation: radiation from planned exposures of human beings must not exceed certain dose limits. Different limit values apply to the general population and to persons occupationally exposed to radiation.

The results of radiological monitoring can be used for the planning of decontamination work to:

- Provide dose assessments;
- Provide risk assessments;
- Assess various scenarios to ensure compliance with the ALARA principle;
- Identify the types of safety and radiological protection required for the protection of workers and the environment.

Efficient monitoring can help reduce personnel exposure through careful planning. In any case, a detailed knowledge of the radioactive inventory is essential.

A comprehensive dose planning programme comprises the following steps:

- Review of data;
- Calculation methods;
- Dose rate and surface contamination measurements;
- Sampling and analysing of the samples;
- Results of operational in situ measurements;
- Review and evaluation of the data obtained;
- Comparison of calculation and measured data.

Methods and resources used to plan individual and collective doses may vary significantly; from using simple excel sheets to complex computing programs using data provided by corporate information systems and management programmes. Multi-professional teams are created for estimation of individual and collective doses of large-scale projects.

#### 4.2. RADIATION DATA COLLECTION, EVALUATION AND SHARING

Data collected and evaluated before and after decontamination activities will determine the results of the decontamination activity. This data is collected at each nuclear power plant for evaluation of collective dose savings, determining potential changes to the method used, potential savings to outage schedules and this information can be used in the development of new decontamination tools and processes. Some NPPs have specific software that is used for preparation and execution of decontamination activities. Other NPPs have huge systems that serve for issuing radiation work permits, resources needed and financial planning. The collected data can be kept as proprietary information or can be shared unofficially or officially. One frequently used way to share this information is the Information System on Occupational Exposure (ISOE).

“Since 1992, ISOE jointly sponsored by the OECD Nuclear Energy Agency (NEA) and the International Atomic Energy Agency (IAEA), has provided a forum for radiological protection professionals from nuclear power utilities and national regulatory authorities worldwide to discuss, promote and co-ordinate international co-operative undertakings for the radiological protection of workers at nuclear power plants. The objective of ISOE is to improve the management of occupational exposures at NPPs by exchanging broad and regularly updated information, data and experience on methods to optimize occupational RP” (see <http://www.oecd-nea.org/jointproj/isoe.html> and [www.isoe-network.net](http://www.isoe-network.net)). As an example of ISOE publication, see Ref. [14].

#### 4.3. FINANCIAL AND HUMAN RESOURCES

Whilst preparing a decontamination activity the ‘cost’ saved from the activity (converted in monetary units as needed) can be compared to the ‘cost’ of performing the activity (equipment, workforce, RP means, doses, etc.). Usually, during an outage, this activity will be performed by a contract service provider. Notably, the staff and contractor cost make a significant portion of the overall decontamination cost. Significant ‘cost’ savings are expected from decontamination.

Regardless the costs, retaining the contamination at the source and having a ‘clean’ nuclear power plant is a never-ending goal at each power station. Not only is there regulatory scrutiny, but it will also have an impact on public opinion and at the end of the day will enable the long-term operation of the NPP.

Decontamination specialists as part of NPP staff are normally responsible for routine decontamination activities during the normal operation of the reactor. But during outage, or for special decontamination activities, most of the NPP plants will need additional decontamination staff as consultants or contractors to provide expertise to reactor staff. Once the decontamination team is assembled, communications and reporting lines are defined, including the chain of command for internal approvals and for interactions with the regulatory body.

Contingency plans and funds need to be available in case of work stoppages, no-shows, or other work gaps.

#### 4.4. TRAINING

Technical and safety training is necessarily provided to the NPP staff, contractors and consultants dealing with the decontamination work. The specific training requirements would depend on the decontamination work which was planned and the prior experience of the workers. For example, a dilute chemical decontamination procedure may require much less training than a concentrated chemical decontamination procedure. New activities require more training than routine ones. Some utilities perform their own decontamination at component level, or this can be contracted to specialist vendors who will perform the maintenance on the equipment. Typically, certain decontamination processes are a specialist vendor activity and the NPP site prefers to contract the work out. However, plant workers may require less training than offsite personnel as far as familiarity with the plant is concerned.

In the case of the NPP staff performing the decontamination themselves, any training requirements would be contained in site-specific documents, procedures and training programmes. In the case of a specialist vendor performing the decontamination, some specific training would be required to be provided by the NPP organization, for example:

- Site access control;
- Emergency and RP procedures;
- Requirements & interfaces for working with site staff – operation, maintenance, RP, industrial safety, outage control centre, chemistry, QM, etc.

The site may require the vendor to produce records of training of the vendor team containing information such as formal qualification, decontamination work experience, specific vendor training courses related to the work to be performed, supervisory and safety training, technical training, etc.

Decontamination workers require extensive training on procedures and system controls to ensure versatility and interchangeability of team members. Rehearsals with mock-ups may be useful depending on the difficulty of the tasks, the intensity of radiation/contamination, and accessibility to the work areas. Visual aids, such as videos and photos taken during similar activities, are often invaluable for training purposes. Mock-up training is normally completed with a full-scale mock run to test worker reactions and system conditions. Radiological and chemical hazards are a key part of the training. Training has to fully adhere to the ALARA principle.

The training programmes for workers or supervisors include some or all of the followings (depending on individual roles):

- Identification and awareness of anticipated safety and health hazards;
- Control techniques or actions that are effective for those hazards;
- Monitoring procedures for characterizing exposure to chemical and radiological hazards;
- Safety and health programme for individuals and sites;
- Hands on training with PPE including respirators as needed;
- Duties, tasks and responsibilities, including use of procedures;
- Hazard communications, e.g. information to oncoming shift, notification of abnormal circumstances, alarms, reporting requirements, sharing of lessons learned, etc.

Additional training to specified classes of workers/supervisors may include such special actions as to:

- Spill containment;
- Medical surveillance and first aid;
- Firefighting;
- Assessment of incidents.

All forms of training require periodic renewal. Documentation of training includes the names of the trainees, training handouts, dates, identification of trainers, and exam scores. Copies of these documents need to be inserted and kept in individual files.

#### 4.5. PROCEDURES

As mentioned earlier, planning for outage decontamination can be routinely or entirely new. For routine decontamination applications (e.g. for periodic outages), procedures are available and the NPP staff responsible for implementation of decontamination procedures will be familiar with the details of the procedures and the working environment. This does not exempt the operator from gathering feedback, monitoring trends and seeking ways to improve performance based on own and others' experience. A learning no-blame attitude is encouraged.

For such routine activities, contractors are often recruited under permanent contracts and they are familiar with the application of these procedures. However, if any new contractors or sub-contractors are involved, specific training will be provided in the execution of technical procedures and in the operations context (NPP layout, administrative procedures, permissions, logistics, orientation etc.).

New activities pose significant challenges on both the NPP staff and contractors. For example, an increased effort is needed to develop new work procedures, a difficult task for people who may not have the full understanding of a complex environment. Therefore, pre-work characterization is paramount in these cases. A related aspect is that decontamination procedures can hardly be the same across the wide variety of facility's conditions. Basically, each room and each component involved in decontamination will call for an ad-hoc procedure to be developed anew: this includes not just the decontamination processes, but the organizational and administrative context: how to enter the working environment (including donning and doffing), how to reach each measuring point, installing piping connections and sampling lines, moving consumables and spare parts in and out working areas, etc.

Some new decontamination procedures that may be needed include:

- Area preparation;
- Handling, mixing, and storing chemicals;
- Introducing chemicals to the work area;
- Removing unused and spent chemicals;
- The mock decontamination run;
- The actual decontamination activities;
- Monitoring the performance of the decontamination (e.g. DFs) through selective sampling and measurements;
- Waste treatment, conditioning, storage, onsite transfer, packaging (shipment and disposal procedures may be the responsibility of NPP staff, onsite or offsite contractors);

- Flushing/rinsing the system, including dead legs;
- Surface reconditioning (passivation);
- Restarting the decontaminated system in a safe mode;
- QM measures;
- Supervision, inspections, reporting and records;
- Emergency procedures.

Other procedures, however, may be already available from previous routine activities and may require only minor adaptations, if any (e.g. workers' dosimetry, use of PPE).

Procedures may have been drafted by the decontamination team (reactor own personnel or contractor), but they will probably require independent review (e.g. by reactor units) and modification to be fully tailored to current NPP conditions (technical and administrative). For example, special care needs to be given to work involving interfaces between the decontamination system and the rest of the plant. It is highly advisable that the drafting of new procedures includes participation of plant staff as they have more knowledge about plant conditions and underlying issues (e.g. hidden or suspected contamination) than contractors.

Additionally, it is expected that those who will be doing the job also concur in the preparation of procedures for two reasons:

- Full understanding and acceptance of any personal risk;
- Training requirements.

The development of procedures starts with a task safety analysis, and it is essential that the procedures consider emergency conditions (loss of power, loss of ventilation, unexpected spills, falls etc.).

Specifications for each room, subsystem and component will be sufficiently detailed to allow ready procurement, acceptance testing, calibration or qualification with no undue delays or ambiguities. Temporary or permanent system modifications will be engineered and recorded through a formal design change process to assure that a safe system configuration is re-established after decontamination and before start-up. Special test facilities for monitoring the response of NPP systems and for requalification of certain components may also require the drafting of ad-hoc procedures.

In a first-of-its kind exercise, there can be some objective difficulties to draft new procedures. It might be especially difficult to strike an optimum balance between two opposite approaches as follows:

- Prescriptive (i.e. covering all details to the point of pedantry; writing procedures in this way for a new operation will inevitably disregard unknowns and unexpected events, and contingencies will be hard to determine in advance);
- Non-prescriptive (leaving ample flexibility to the implementers and counting on their experience to solve any unforeseen issues).

Potential issues and solutions with new procedures are highlighted in Table 1.

TABLE 1. POTENTIAL ISSUES AND SOLUTIONS WITH NEW PROCEDURES

Potential issues	Solutions
Unworkable	Include implementers in preparation of procedure
Out of date (e.g. trying to adapt existing procedures to new purposes)	Regularly reviewed as experience is being gained
Incomplete/inconclusive Too long Overprotective Conceal/underestimate hazards	Right balance between procedural compliance and hands-on skills
Obsessed with procedural compliance	Linked to specific training and individual qualifications

#### 4.6. LOGISTICS

When the facility undergoes decontamination, materials, equipment and components in place during operation may hinder manned access or the introduction of new machinery/chemicals. Depending on the extent of proposed decontamination, the work area can be modified to take account of new activities. Some of these changes may remain following completion of decontamination work; in other cases, it is important that the pristine status be re-instated after decontamination. In general, these logistic activities are intended to:

- Evaluate the efforts necessary to prepare the site for decontamination;
- Identify specific activities that can provide a safer workplace;
- Remove SSC that can interfere with the objectives of decontamination.

In early phases of decontamination planning, radiological hazards tend to be associated to preventive actions including:

- The radioactive inventory may need installation of provisional shielding;
- Radioactive substances are to be removed and packaged in containers;
- The decontamination method can produce spread of contamination and containment/confinement barriers need to be installed.

Industrial hazards in decontamination are not negligible and will require logistic plans. Hazards of this kind may include among others:

- Structural changes e.g. to insert new piping, electric lines;
- Heating, ventilation and air conditioning (HVAC) systems may need modifications;
- Interim utilities may substitute for existing ones;
- Electrical requirements can be significant for subsystem chemical decontaminations. More than 1000 Amperes (A) may be necessary. Locating an acceptable power source as well as wire routing needs to be considered.

Following removal of HVAC or demolition of engineering barriers, PPE may be required to keep personnel protection at safe levels. Portable lighting may be necessary as electrical power to the area may be discontinued. Temporary containment structures (e.g. plastic tents) are



normally used for decontamination work to prevent contamination spread. Portable HVAC may be necessary to provide air filtration to containment tents.

Site preparations also include provisions for spaces and activities such as:

- Material handling (hoisting, storage of empty and filled drums, etc.);
- High temperatures (cutting, welding, heating, etc.);
- Scaffolding, ladders, fall protection;
- Storage of clean and used decontamination tools and consumables;
- Floor loading limits need to be addressed for chemical decontamination equipment. Specifically, the ion exchange (IX) and shield my need a weight distribution plan.

In parallel, the onsite and/or offsite laboratory used in support of decontamination activities may need to be upgraded due to such factors as:

- Unusual types of sample materials (e.g. pipe sections of variable geometry);
- Unusual radionuclides;
- Complicated radio-chemical analyses requiring specialist expertise and/or ad hoc training;
- Large number of samples to be analysed in a short time period;
- Sample storage and archiving to document decontamination achievements;
- Laboratory waste management;
- Storage of hazardous materials.

Supplies, tools and equipment, and specialist services have to be procured in advance of the decontamination. Detail needs will be defined by the specific decontamination method, requirements and procedures. Conditions for procurement of supplies (e.g. consumables) and equipment include the determination of costs, delivery dates, and shipping requirements. It is convenient that alternate vendors be identified in case of delays. Other concerns of procurement include receiving areas, acceptance criteria, onsite transfer, storage capacity, and special requirements such as fragility, flammability or safety.

Specialized services and consultants may be needed for the decontamination project. Related contracts specify among others performance and reporting requirements, hold points and milestones, schedules, payments and any penalties in case of deviations or delays.

Labour requirements can be more accurately determined on the basis of the decontamination procedures. Once the skills and numbers of workers are identified, sources of this labour can be located, and related costs estimated. Some workers will be available from the NPP staff. Others will be staff from the prime contractor company or will be sub-contracted by the prime contractor. It is important that contingency plans be made to compensate for missing labour due to unpredictable events such as work interruptions for incidents or bad weather, illness, or resignation.

The needed modifications to SSCs are completed to facilitate the insertion, handling and removal of tools, decontamination solutions, waste etc. and to permit isolation of sections of the system. This logistic work will be performed taking account of accepted criteria regarding materials selection, workmanship, QM, acceptance testing, and calibration. 'As-built' drawings are prepared to document the modifications for future work.

Components or systems may be isolated in different ways during decontamination. Sections of the system can be "valved" off. Blind flanges can be inserted at piping connections. Water dams and freeze plugs are also possible. Component removal is another option e.g. when there is no

other access to the component or when failure of the isolation would cause a very serious damage.

If existing valves are used to isolate systems, it is important to ensure that valve components will not be damaged by decontamination solutions and fail (in case of failure, a 'fail-safe' configuration have to be ensured). Blanks or spool pieces are used as needed. Some components may be impossible to isolate, and water flush lines may have to be installed to protect these components from corrosion; the alternative is to replace such components after the decontamination.

Where the decontamination systems interface with the NPP, interconnections will be installed, regularly checked and maintained. These may include inter alia the following:

- Utilities - water, sewer, waste systems, electrical power, steam, compressed air, vacuum, lighting;
- Ventilation - HVAC, exhaust air with pre-filters, high-efficiency particulate air and charcoal filters;
- Radiation- area monitors, sampling of and monitoring of liquid and airborne discharges;
- Safety systems- fire alarms, fixed and portable extinguishers;
- Communications - phone, fax, radios, intranet.

When all the above-mentioned preparations are completed, an operational readiness review needs to be performed to ensure that personnel, organization, tools and hardware are ready for implementation of the decontamination project. Personnel will have been identified, trained and tested. Management controls include the definition of roles and responsibility, availability of the whole set of procedures, and a safety programme in place (approved by the regulators as needed).

Construction and installation of the decontamination system and interfaces has to be complete and validated including maintenance and survey provisions. The operational readiness review is intended to systematically identify any oversights or inadequacies in the preparatory work. The integrity of the decontamination system can be tested by a mock run (e.g. with water prior to the actual injection of chemicals). When all these activities are successfully ended, the actual decontamination can start.

#### 4.7. CONTRACTORS AND SUPPLIERS

A critical issue in planning (by especially, but not limited to, organizations with limited or poorly trained in-house resources) is to make decisions on the need, timing and extent of external contractors. While several operating organizations have created a pool of internal specialists for routine decontamination tasks, other organizations may need to recourse (partly or fully) to external contractors. This decision tends to be attached to corporate policy decisions and is the responsibility of the top management: in any case it is a key component of a detailed decontamination strategy. As for most decontamination activities internationally, many competent contractors are available, a rigorous process is needed in identifying and selecting one or more for the project in question: however, for more complex tasks such as full system decontamination, the international market is restricted to few companies.

Cost-effective management calls for an organizational structure that is unambiguous, orderly, responsive, and focused on safety and cost control. Management layers need to be minimized using a prime contractor coordinating other contractors or preferably one single contractor

taking the lead of all decontamination tasks from planning to implementation. Multiple layers of management increase the overall costs as the cost of managerial and professional services will be added to the cost of actual decontamination.

The use of contractors may create several issues. While the licensee can delegate work to contractors, the licensee's legal responsibility remains unaffected using contractors. The licensee has an obligation to prove to the regulators to be an "intelligent customer" and to maintain good understanding and supervision of the contractor's work. If there is lacking in-house knowledge or expertise to manage contracts effectively, then problems such as delays, cost overruns or safety implications are likely to occur. However, whereas the legal responsibility remains with the licensee, the contractor is given adequate freedom of manoeuvring and accountability in carrying out the decontamination.

Regulators can get concerned about safety and RP issues where licensees tend to transfer their responsibility to contractors without ensuring adequate control. See the UKAEA Dounreay case presented in the IAEA publication Ref. [15]. To alleviate these issues some operating organizations, aim to share performance risk with contractors, especially commercial risks. All-encompassing, turnkey contracts can save money and time in simplifying contacts between customer and contractor, but they can be hard to manage from the standpoint of control by the licensee.

Fixed-price contracts with incentives for cost, waste and schedule reduction are normally used where feasible. Technical support organizations (TSOs) can effectively assist the operator at each stage of the decontamination project and can be considered kind of contractors or partners. Generally, most of the consulting support provided by the TSOs is during the planning stages. For example, there are many RP issues in a decontamination project, where the expertise of the TSOs can ensure safe decontamination and best practices of addressing waste management.

In general, the following defines rules of engagement for an efficient management of contractors:

- Acquire accurate descriptions of the organization, roles and responsibilities of contractors, including certifications, qualifications and previous training arrangements. This is the basis for additional training to be provided to the contractors by the NPP organization;
- Consider contractor's (internal and external) operating experience in similar activities;
- Assure consistency between the QM programme of the operating organization and that of decontamination contractors: this is especially important when work is managed by mixed teams (for example, HP monitoring is typically performed by NPP staff even when contractors do the physical work);
- While the operating organization can delegate work to contractors, it remains legally responsible: therefore, the operator is bound to ensure adequate supervision of contractors' activities always;
- Early and frequent interaction between contractors and NPP managers is advisable;
- Execution of activities remains open to contribution by individual workers – including the NPP staff- throughout all decontamination activities; a questioning attitude will help; and
- All decontamination activities from preliminary measurements to final certification of accomplished mission need to be fully documented and passed on for future use.

External decontamination contractors are duly certified for the job according to national legislation/regulations: if decontamination is carried out with own staff, the operating organization has normally in place own engagement rules including qualifications.

## 5. TECHNIQUES OF DECONTAMINATION

Decontamination activities are mainly carried out to protect workers performing maintenance tasks during and after outages in order to lower external exposure and risks of internal exposure due to inhalation of contaminated particles.

For this purpose, depending on the type of reactor, on the type of outage and on the dose rates measured, the most suitable technology and/or process for the decontamination has to be implemented.

Most of decontamination processes or technologies are proprietary, and the patents are held either by the specialist vendors performing this work (e.g. Framatome, Westinghouse, Hitachi, Toshiba, etc.) or by utilities such as EDF in France. These technologies are all chemical based decontamination processes. The selection of technologies would once again depend on the decontamination activity which is being planned. Certain decontamination processes are more suited to component level decontamination and others to sub-system, system or FSD. The utility would need to set these requirements/objectives for the decontamination and then establish which of the available processes can achieve them.

Typical requirements are:

- Component, sub-system, system or FSD;
- Available duration during the outage for the decontamination;
- DF required;
- Waste volume limitations;
- Available budget;
- Nuclear qualified decontamination equipment (e.g. seismically qualified);
- Approved consumables/chemicals (qualified for materials, criteria to be respected);
- National Legislation (environmental, radiation safety);
- Safety Authority requirements.

There are decontamination processes other than diluted liquid processes such as hot spot reduction techniques, high pressure water lancing, foam and gel applications, laser ablation, mechanical decontamination (blasting, etc.)

Chemical and physical processes implemented to decontaminate circuits and system materials (stainless steel, inconel, stellites, etc.) have to be qualified for the materials concerned. Decontamination to reduce occupational exposure, to reuse/recycle materials and to reduce and optimize RAW concerns auxiliary circuits, pools, materials and concrete surfaces of building.

### 5.1. DECONTAMINATION OF CIRCUITS

Decontamination of circuits may be proceeded by:

- Chemical process to remove activated corrosion products from pipe surfaces (redox, pH, temperature and flow rate control). The chemical solution to be

- employed depends both on the composition of materials of the circuit and the chemical form of deposits to remove;
- Ultrasonic fuel cleaning (UFC), which was developed in 1999, has been showing success in source term reduction on US BWRs. The high-efficiency UFC (HE-UFC), which was introduced in 2011, offers improved operation and crud removal. HE-UFC is effective at removing most deposits present on fuel surfaces following the ordinary shutdown procedure using hydrogen peroxide injections;
  - Mechanical process to remove loose contamination: blasting, high pressure water lancing and filtration to eradicate this contamination;
  - Combination of the two previous processes.

## 5.2. DECONTAMINATION OF POOL CAVITIES

Decontamination of pool cavities may be proceeded by:

- Chemical process: implementation of decontamination solutions, foams (degreasing) and/or gels and water rinsing;
- Mechanical process: high pressure water lancing (pressure effect), rotating brushes, scraper and/or cloth implementation (rubbing effect), vacuum cleaner (to eradicate loose particles);
- Combination of the two previous processes;
- Use of remote operated submarines equipped with brushes to do underwater scrubbing;
- Local (a.k.a. in-situ) electrochemical decontamination using swabbing or spraying electrodes;
- Intervention of divers to eradicate localized hot spots under water.

## 5.3. DECONTAMINATION OF TANKS AND SUMPS

Decontamination of tanks and sumps may be proceeded by:

- Chemical process: chemical solutions, gels, foams and water rinsing;
- Mechanical process: blasting, high pressure water pressure lancing, vacuum cleaner to remove the sludge;
- Remote controlled mechanisms;
- Strippable coating;
- Removable parts;
- Chemical process: implementation of decontamination solutions, foams (degreasing) and/or gels and water rinsing;
- Physicochemical: electrochemical decontamination (in the decontamination bath, swabbing electrode);
- Ultrasonic cleaning: water, surfactants, detergents, acids, alkaline;
- Mechanical process: high pressure water lancing (pressure effect).

## 5.4. DECONTAMINATION OF CONCRETE

Concrete surfaces can be decontaminated by:

— Mechanical methods:

- scabbling (removing a thin layer of concrete from the structure);
- shaving (undercutting of concrete layers);
- grinding.

— Blast method;

— Thermal stress treatment:

- microwave irradiation;
- flame scarfing.

Concrete pieces/buildings can be decontaminated by:

— Cutting/sawing;

— Drill and spalling.

## 5.5. DECONTAMINATION OF OTHER EQUIPMENTS AND MATERIALS

There are specific procedures (chemical and or physical processes) adapted to decontaminate specific equipment such as:

- Steam generators;
- Pumps from RCS, from chemical and volume control system (CVCS) and from residual heat removal system (RHRS);
- Heat exchangers CVCS (no regenerative and regenerative) and RHRS (regenerative);
- Pipes (RCS, CVCS, RHRS, etc.);
- Pressurizers;
- Evaporators;
- Vessel heads;
- Valves (RCS, RHRS, ...);
- Lead containers;
- Electrical materials;
- On-line gamma measuring chambers;
- Spent fuel casks;
- Control rod drive mechanisms.

## 5.6. EXAMPLES OF DECONTAMINATION METHODS

There are literally a hundred of decontamination techniques or methods. A few of them either performed in situ or in decontamination enclosures during NPP outages will be further reviewed, as:

- Water wash;
- Foams and gels;
- Electrochemical decontamination;
- Abrasive blast;

- Dry ice blasting;
- Strippable coatings.

### **5.6.1. Water wash**

Nuclear facilities are often decontaminated using aqueous solutions. These processes generate effluents, and the contact time between the items to be decontaminated and the decontamination solution is frequently too short to guarantee a good DF. To improve the DFs chemicals can be added to water; it is also possible to increase temperatures, steam jetting and use brushes (including rotating). However, the water employed might cause a concrete risk of spreading contamination to nearby areas.

To reduce these inconveniences pressurized water jets have been employed that use smaller volumes of water; historically, water jets have been used at higher and higher pressures. Containment is assured by water jetting in enclosed cells rather than in open spaces. Pressurized jets present risks of industrial safety.

### **5.6.2. Foams and gels**

The drawbacks inherent to water process problems during decontamination can be eliminated using a foam- or gel-based medium. These mediums are generated from commercially available chemicals and can be applied with a spray nozzle, brushes or by simple pouring. By adhering to the contaminated surface for a long residence time, activity is encapsulated into the structure of the foams or gels allowing small amounts of decontaminants to be removed. These solutions are satisfactory reagents for decontaminating hot spots or selected areas. After use, they are removed by rinsing, spraying water or vacuuming. In general, the major disadvantage for foam and gel processes is that they tend to achieve lower DFs than similar aqueous-based systems. The volume of liquid waste generated is only 1 to 2% of that found in decontamination baths (soaking procedures).

### **5.6.3. Electrochemical decontamination**

Typically, this is the chemical process when decontamination technique is performed in solution baths outside the NPP and the goal is to remove all oxide films (activity) from the surfaces. The metal item to be decontaminated serves as an anode of an electrolytic cell, and high potential areas (activity layer) are preferentially attacked by ions from the solution and oxidized. The resulting oxidized activity dissolves into the solution resulting in surface decontamination of the metal item. Production of hydrogen as by-product from oxidation process may form explosive mixtures (if more than 5% in air) and requires adequate ventilation. After electrochemical decontamination, the item is removed from the electrolyte and rinsed in hot water to prevent the oxidation of the base metal. If the item decontaminated is to be reused, the technique uses a high current density to produce a smooth surface. The secondary waste generation could be reduced by the regeneration of the electrolyte (e.g. resins, precipitation).

The precipitation regeneration process includes the following steps:

- Transfer electrolyte to a separate tank;
- Adjust pH;
- Precipitate the dissolved iron as iron oxalate;
- Reuse electrolyte for decontamination;

- Evaporate spent solution;
- Transform it into solidified waste for storage or disposal.

However, the solutions become saturated with non-removable ions and require appropriate processes for final treatment and conditioning (like in chemical methods).

In situ electrochemical decontamination is a technique (not yet fully commercial) which can be used to decontaminate large tanks, the interior of long pipes, pool walls, and other contaminated surfaces that cannot be neither transported to nor immersed in an electro-polishing bath. This technique uses a movable cathode being held at a fixed distance from the surface: it does not require large volumes of electrolyte, so it does not generate large amounts of liquid waste. It is especially effective to remove hot spots.

#### **5.6.4. Abrasive blast**

Mechanical decontamination with abrasives uses the power of abrasives projected at high speed against the surface to remove layers of base material. There are two categories:

- Wet environment: fluid carrier is water;
- Dry environment: fluid carrier is air or centrifugal force (abrasive is thrown on the surface by rotating disc).

It is important to ensure the recycling of the abrasive to reduce the volume secondary waste. Mechanical decontamination methods are normally performed in a dedicated enclosure with suitable ventilated system to remove re-suspended contamination and aerosols.

For selecting such a method, the following should be considered:

- Select an abrasive with a long lifetime (a recycling issue);
- Minerals (magnetite, sand, garnet etc.);
- Steel pellets, aluminium oxide;
- Ceramic, glass beads;
- Plastic pellets;
- Wet and dry techniques allow recycle the abrasive by separation;
- Filtration or decantation in wet sandblasting;
- De-clogging filter (ventilation) in dry sandblasting;
- Air contamination in dry sandblasting is a critical factor (risk of cross contamination);
- The presence of water in wet sand blasting enhances the corrosion process on carbon steel (rust is a contamination trap);
- Type of use manually (inside the decontamination box, outside the decontamination box) or remote controlled.

#### **5.6.5. Dry ice blasting**

This process utilizes dry ice (solid CO<sub>2</sub>) which is ground into rice-like pellets or tiny particles. These particles are then accelerated to supersonic speeds via a blasting unit to the surface to be decontaminated. Upon impact, the dry ice immediately turns from its solid state into carbon dioxide vapour. Both the mechanical energy transferred upon impact and the energy released by the conversion from solid to vapour produce the cleaning effect on the base metal. The vapour disappears, leaving behind solid removable contaminant that can be removed by



conventional means as solid secondary waste. The vapour is filtered by standard air cleaning methods to remove any possible contaminant aerosols.

Dry ice blast cleaning is non-abrasive to the impacted surface. However, the generation of gaseous CO<sub>2</sub> requires an efficient removal ventilation system for personnel applying this technique.

### **5.6.6. Strippable coatings**

These coatings generally share a polymeric basis (e.g. decongel) and are doped with surfactants, organic or inorganic acids, sorbents, chagers, peptizers, for adjustment of strength, elasticity, adhesion, etc. These polymeric solutions can be applied with a spray nozzle, brushes or by simple pouring. By adhering to the contaminated surface for a long residence time, activity is encapsulated into the structure of the foams or gels allowing small amounts of decontaminants to be removed. Upon drying, the resulting film or coatings can be readily stripped off. This technique enables the removal of surface activities and corrosion products from surface of the base material. Activity removal from pores trapped in the base metal depends on the viscosity of the applied coatings and could limit the removal of activity in metal pores.

## **6. ACHIEVEMENT OF DECONTAMINATION**

### **6.1. KEY FACTORS FOR A SUCCESSFUL DECONTAMINATION**

#### **6.1.1. Preparation and realization**

There are a lot of factors contributing to a successful decontamination either at the stage of the preparation or at the stage of the realization as detailed in section 4. For example:

- Choice of the method;
- Quality of the procedures;
- Skills of the contractors;
- Training of the workers;
- Quality of the oversight of the contractors by the own staff;
- Time allocated for the decontamination in the outage planning;
- Type of equipment and of materials; etc.

#### **6.1.2. Work and project management**

Written instructions are key to the success of decontamination projects. These plans/procedures will guide the workforce through the process, ensuring key actions are completed. They will contain trigger points for the project. An example would be for reactor cavity decontamination: when does a plant call it good enough or what remaining contamination levels are desirable to stop decontamination efforts? This has to be predetermined. The guidance has also to contain any precautions such as controlling demineralized water introduction into the reactor during cavity decontamination.

Project management (PM) oversight is a key factor in successful decontamination activities. PM provides the coordination needed to successfully implement while supervisors/foremen

direct work activities in the field. Step guidance will provide instructions on the decontamination activity, including work permits, hold points, stop work and success criteria.

### **6.1.3. Cross departmental consideration**

Months in advance of the scheduled decontamination activity, the decontamination project manager has to insert the activity along with any predecessors and successors into the schedule. This includes waste management as well. All activities will need to be reviewed during schedule review challenges in order that the station can see each activity on the overall work plan. Support from outside organizations, if needed, will have to be identified during the scheduling process. As the project progress, plant schedules will be updated. The written guidance for the decontamination project will need to have all the required actions from other departments.

Large decontamination projects, if managed correctly, have the potential to realize lower waste generation, therefore reducing cost and personnel exposure. Planned management of the project is suggested with a waste control specialist to coordinate the activities associated with waste generations and disposal. Inputs from several departments such as chemistry, outage management, and RP are needed to optimize waste reduction.

Planning will include the expected volumes of waste to be generated along with the type of waste. For example, will waste water be processed via filtration or demineralizers? Cleaning agent's material safety data sheets need to be reviewed for impacts on plants components and RAW treatment systems/media. Failure may result in the generation of a mixed hazardous waste and significantly increase disposal costs.

It is important to stage the appropriate waste packaging in the evaluated location to reduce handling so that radiological exposure and resource use cost time are kept at a minimal. If the decontamination project is outage related, outage management will need to be consulted to ensure the waste can be easily removed and that it will not interfere with other activities. ALARA engineering will need to evaluate any shielding needed for the waste.

## **6.2. DECONTAMINATION FACTOR**

### **6.2.1. Definition**

The efficiency of different decontamination processes has to be evaluated beforehand to select the most suitable to the NPP in question. The most common parameter for a preliminary evaluation is the decontamination factor (DF).

According to the definition given by the IAEA Safety Glossary [16], the DF is “the ratio of the activity per unit area (or per unit mass or volume) before a particular decontamination technique is applied to the activity per unit area (or per unit mass or volume) after application of the technique:

- This ratio may be specified for a particular radionuclide or for gross activity;
- The background activity may be deducted from the activity per unit area both before and after a specific decontamination technique is applied.”

DF is calculated as ratio between pre-decontamination and post-decontamination measurements:

$$DF = M_b / M_a$$

Where  $M_b$  = measurement before decontamination (at a reference point) and  $M_a$  = measurement after decontamination (at the same reference point as  $M_b$ ).

Regarding the kind of measurements, the DF can be defined (or calculated) by two different methods. The first method is to use radiation measurements. This is called the radiation DF and is defined as:

$$\text{Radiation DF} = I_b / I_a$$

Where (see Ref. [17] )  $I_b$  = dose (radiation) rate before decontamination (at a reference point) and  $I_a$  = dose (radiation) rate after decontamination (at the same reference point as  $I_b$ ).

This definition is widely used in decontamination for operating plant, where the radiation measurements referred to are dose rate area measurements. In this case,  $I_b$  and  $I_a$  are given in mSv/hr or mGy/hr. In many cases the radiation measurements can be taken from monitor counters located near or over the surface to be measured.

The second method is to use activity measurements. This is called the decon DF and is defined as:

$$\text{Decon DF} = A_b / A_a$$

Where  $A_b$  = activity before decontamination (at a reference point), Bq/cm<sup>2</sup> and  $A_a$  = activity after decontamination (at the same reference point as  $A_b$ ), Bq/cm<sup>2</sup>.

This definition is widely used for off-line decontamination where the surface activity can be properly measured. In laboratory studies and research, the decon DF is more widely used than the radiation DF. As mentioned before, each numerical value of DF has to be referred to a single measurement before decontamination and a single measurement after decontamination. This means that the DF can be of relevance only for single points or for very small surfaces or components (which can be measured with a single operation). In any other case, where many measurements have been carried out, an average DF will be calculated.

In addition, it is important that measurements be taken under steady conditions (e.g. long after the activity of the component/system being decontaminated is subject to fluctuations).

The average DF can be a sufficient indicator of successful decontamination if subsequent (post-decontamination) activities e.g. maintenance involve all parts of the component/system in question and for similar times: but if most subsequent activities focus on one part of the component/system, local DFs will be required.

The activity of the background is a parameter which is strongly dependent on the procedures and instrumental techniques used for the activity measurements. High radiation background (typically due to radiation sources near the measuring point) can considerably mask the decontamination effect.

For a proper evaluation of a DF, the background has to be deducted from measurements both before and after decontamination. The influence of the background levels is particularly strong when initial or (more likely) post-decontamination levels are close to background. For evaluation of DFs based on the above-mentioned formulae shielding contiguous sources of radiation may be necessary to provide accurate data: this is not always easy as there can be several radiation sources nearby.

DFs are widely available in the technical literature. However, experience shows that DFs drawn from laboratory, small-scale trials, simulated contamination coupons, or under unspecified conditions (e.g. temperature, humidity) have to be taken cautiously if in-the-field applications are pursued. In fact, the working environment (i.e. components/systems that have operated in

real conditions for a long time) is unsuitable to be well represented under the ideal, “clean” conditions of laboratory or small-scale experiments.

While experiments keep their validity as the first step in validating a decontamination process, still more trials under conditions as close as possible to reality are needed in most cases. It has to be emphasized that no decontamination process fits all circumstances and careful selection of the preferable process is needed. For example, the selection of an FSD process requires a good knowledge of the corrosion layers and crud deposits on primary coolant surfaces. Normally these deposits chemically differ in BWRs and PWRs because of different reactor chemistry and system materials.

BWRs have an oxidizing chemistry, which tends to form higher iron oxidation state (hematite) externally and ferrite internally. By contrast, PWR corrosion products consist of a loose crud layer on top of a magnetite strongly adhesive spinel embedding chromium in the +3 valence, which is insoluble without further oxidation. For US BWR plants that have employed hydrogen water chemistry the BWR films behave more like traditional PWR films. However, due to the open circuit design the deposits in BWRs are much more significant than in PWRs. It is also essential to distinguish between activated corrosion products and fission products (from fuel failure), because different decontamination processes are required.

In some cases, it might be appropriate to use measurement of smearable contamination as an indication of the success of the decontamination process. This could be applied to the reactor cavity decontaminations for example.

### **6.2.2. Parameters affecting the decontamination factor**

DF strongly depends on the initial contamination levels: the higher initial contamination levels are, the higher DFs are expected to be, and subsequent decontamination passes on the partly decontaminated materials are likely to give lower and lower DFs.

The following gives a list of parameters affecting DFs:

— System related:

- Material type (carbon steel, stainless steel, nonferrous). Geometry (e.g. straight-run pipes, vertical vs horizontal direction, pipe bends and elbows, small vs large diameters, pipe restrictions). Vessels and tanks;
- Smooth vs rough surfaces;
- Flow-obstructing items (e.g. valves, components, flanges, traps and ‘dead legs’);
- Direction of impinging flow;
- Speed of the decontamination chemicals (e.g. turbulent vs laminar flow);

— Contamination characteristics:

- Extent and uniformity of contamination spread;
- Physical, chemical and radiological nature of contamination layers;
- Fixed vs loose contamination;
- Single or multiple contamination layers;
- Plant operating history;
- Fuel cladding failures (resulting in a significant presence of fission products);
- Water chemistry control;

- Steam generator tube leaks;
  - Soluble vs insoluble deposits;
- Corrosion effect:
- Attack on base metal;
  - Attack on contamination layer;
- Solvent stability and concentration:
- High temperatures cause solvent breakdown;
  - Concentration decreases as contamination reacts with solvent;
  - Solvent additions required to maintain concentration;
  - Chemistry control during process;
- Redistribution of contaminants:
- Plate-out in ‘dead-legs’;
  - Requires sequestrants to keep contamination in solution;
  - Causes ‘hot spots’ in system;
- Process temperature:
- Most effective at elevated temperatures (80 °C-120°C).

These parameters have to be considered to estimate the ‘true’ DFs for the case in question. They are also going to determine the experimental conditions to test a proposed decontamination process in lab or in a pilot plant: simulated conditions have to be as close as possible to the real ones.

During decontamination for maintenance, as typical for outages, components and systems are supposed to be reused for the same functions after decontamination and therefore have not to be damaged by the decontamination process; if so, the use of very aggressive decontamination methods (high DFs) is generally inappropriate. Therefore, in outage decontamination DFs up to 10 are quite normal. Frequent decontaminations with dilute solutions normally reduce the average radiation fields in the primary coolant to an extent enough to permit routine maintenance with an overall saving in dose exposure. Acceptable DFs for these processes may be as low as 2 and still be worth. By contrast, in decontamination for decommissioning, destructive techniques are allowed that presents the possibility of free releasing of the material.

As discussed above, DF is only one factor affecting the overall performance of the decontamination process: many other factors contribute to the selection of a decontamination method (e.g. secondary waste generation and management, required skills and training, technological readiness including any need for additional R&D and costs).

### 6.3. MITIGATION OF RECONTAMINATION AND CONTAMINATION BUILDUP DURING DECONTAMINATION PROCEDURE

DFs for some chemical processes may be comfortably high but the continuing contact of contaminated solutions with cleaned surfaces may cause re-deposition of the contamination at another position, resulting in little or no general gain. Thus, previously clean areas may become

contaminated and constitute a broader radiological problem than before. Recontamination is sometimes minimized by reducing the contact time of the decontaminants with the surfaces, but this reduces the initial DF. Therefore, good decontamination processes and procedures have to balance an acceptable DF with minimal recontamination.

There are actions to help mitigate recontamination after decontamination described below in this section. While there is no absolute guarantee that the recontamination rate will be reduced with these actions, it could be worth spending some extra time and money to evaluate them.

Reducing the source term and origin of radioactive nuclides, e.g. Ni, Co, Ag and Sb is probably the most effective and is a proven industry best practice. This has to be a continuous improvement practice which is continually addressed by all NPP's whether a specific decontamination exercise is undertaken or not. It is effective because it allows removing the radioactive source before it is formed, but it is also expensive because replacing material before the end of its service lifetime is not so cost-effective. An example of this is the removal of the hard-facing alloy stellite used in primary system valve seats. Stellite has high  $^{59}\text{Co}$  concentration (some 60%), which is released through wear and corrosion. When cobalt is released in systems with a flow path to the reactor core, it can become neutron-activated to  $^{60}\text{Co}$ . It also needs to be considered that the source of the radiological contamination is not always easy to identify and locate. There are also other ways to mitigate recontamination after decontamination and radiation field build-up.

Passivation of system surfaces, for example, is a way to prevent recontamination after decontamination. Specific passivation steps have to be taken after decontamination to ensure that a protective oxide layer is built up after decontamination is performed. These passivation steps could be specific to the design of the NPP (e.g. using heavy water for PHWR's) and to the materials of the system(s) that were decontaminated. This passivation process can prevent the radioactive species present during operation from being incorporated into these oxide layers and reduce long term radiation build-up. Proper passivation also reduces the amount of soluble iron and nickel ions in the primary coolant during the reactor start-up and hence mitigate crud formation on the fuel surfaces.

Zinc injection is used by many NPPs to mitigate  $^{60}\text{Co}$  build-up on primary system surfaces. The period after decontamination when the radioactive contamination is low on system surfaces is a convenient time to start with zinc injection. The dose rate is low, and zinc injection could be used to mitigate further  $^{60}\text{Co}$  build-up on system surfaces. Significant success has been reported with zinc injection for reducing dose rates in BWR's in the US and is currently employed by the entire US BWR fleet. At EDF, zinc injection has been used on a number of PWR's both for dose reduction and primary water stress corrosion cracking mitigation. Zinc injections also result in thinner oxide films on material surfaces, hence reducing the possible sites for activated corrosion products to adsorb on. It is recommended to generally implement zinc injection after system decontaminations.

Another activity that seems to be important to mitigate recontamination after decontamination is the flushing of systems and dead-ends with demineralized water to avoid that radioactive particles (hot-spots) depositing again on surfaces and/or components. This is an important part of the decontamination activities planning as particles can be mobilized by the decontamination process and settle in low flow areas such as dead legs, valves, pipe bends, etc. If these particles are not removed by a focussed flushing program, previously non-contaminated areas could become contaminated.

Extended demineralized water clean-up with increased flow using resin and/or filters after decontamination is recommended if possible. Once again this can prevent the depositing of radioactive particulate matter in low flow areas of the plant. Planning for filter and IX resin

change-outs during this flushing program have to be included in the decontamination activity schedule.

#### 6.4. KNOWLEDGE MANAGEMENT

Decontamination operations may span over an NPP service life of at least 40 years (currently extended in some Member States to 60 years, with proposals to further extend it to 80 years). A period of many decades is long enough for the knowledge acquired in decontamination to disappear with the ageing and retiring workforce -unless specific provisions are taken. To this end the role of records is crucial.

It has to be recognized however, that being outages frequent events in an NPP lifetime, there are good chances that the knowledge acquired during previous decontamination operations will not be lost, instead it will be passed on along a line of experienced implementers (reactor staff and contractors). However, there is a potential for the “tacit knowledge” acquired during decontamination activities to get lost due to unexpected events such as illness or early retirements. It is the loss of minor, practical details (a.k.a. the “nitty-gritty”) that often make the difference.

Properly managed succession planning (incl. briefing / debriefing sessions etc.) is expected to avert these mishaps. However, the loss of practical information in outage decontamination cannot be totally excluded. Therefore, relevant records (“explicit knowledge”) have to be produced, assessed and kept with the assumption that they will be consulted and used by newcomers not necessarily familiar with the NPP configuration and the know-how of the deployed decontamination processes: to this end, records have to be drafted and compiled with a wealth of details, conservatively including even those that could appear superfluous to more experienced decontamination players.

Records have to include all aspects related to decontamination planning and execution, including but not limited to:

- Rationale for decontamination;
- Pre-decontamination physical and radiological characterization;
- Criteria for selection of decontamination processes and methodologies;
- Administrative, regulatory and logistic requirements/constraints;
- Preliminary and detailed plans;
- Operating procedures;
- Training;
- Waste generation and management;
- Safety assessment;
- Post-decontamination physical and radiological characterization;
- Human, scientific and financial resources employed;
- Measures taken in view of reactor re-start (e.g. proper re-passivation of the decontaminated surfaces);
- Evaluation of decontamination performance (using different performance indicators e.g. radiological inventory removed, secondary waste generated, costs, occupational doses, validation of method and procedures etc.);
- Lessons learned (including tips, hints, incidents and near misses).

As mentioned earlier, record management is only part of the broader knowledge management, which includes also human resources, staff and contractor qualifications, technical competence

management, primary and continuing education, stakeholder involvement, organizational and managerial schemes, etc.

A general review of knowledge management as applicable to RAW is given in [18] and [19].

## 7. MANAGEMENT OF WASTE GENERATED DURING DECONTAMINATION

### 7.1. CONTEXT

Decontamination activities generate RAW to be managed in a manner that protects human health and the environment now and in the future.

RAW management takes into account treatment, conditioning, packaging, storage, transportation and disposal of waste considering costs and radiation exposure of the workers, the public and the environment. This is why waste minimization has become a major part of the waste management policies. Among reference reports published by the IAEA one can quote Ref. [20] and the more recent, focused on technological advances [21].

### 7.2. WASTE MINIMIZATION

The fundamental principles of waste minimization can be summarized as follows:

- Keep the generation of RAW to the minimum possible or practicable;
- Minimize the spread of radioactivity to the greatest extent possible;
- Optimize possibilities for recycle and reuse of valuable materials; and
- Minimize the amount of RAW generated by applying adequate treatment technology.

A review of waste minimization methods, addressing decontamination operation, was published by the IAEA in 2001 in the publication Ref. [22].

RAWs resulting from decontamination need to be processed according to the types of waste, concentrations of radionuclides and requirements for waste storage and/or disposal. The choice of treatment/conditioning processes will depend on a variety of parameters, including:

- The physical, chemical and radiological properties of the waste;
- The type of treatment processes available;
- The location of the requisite processing equipment, e.g. whether the treatment facilities are on-site or at a nearby location;
- The transportation, storage and disposal alternatives available;
- Economic considerations.

Usually, decontamination during outage is relatively mild in order not to damage components and systems of the nuclear plant: however, in this way very limited amounts of materials can be decontaminated to comply with unrestricted release criteria.

Administrative controls and management of operating NPPs during decontamination make a significant part of the waste minimization strategy. These include:



- Characterization of the types amounts and activities of waste at their different points of generation;
- Establishment of a waste accounting and traceability system to quantify the sources, types, amounts, activities and dispositions of waste materials;
- Identification of all points in the working environments and all stages in the process where it is possible to prevent materials from becoming RAW. Individual decontamination tasks have to be reviewed constantly;
- Improvement of operational practices and management for sorting and segregating waste streams at their sources to prevent mixing of different waste categories;
- Sorting of waste of the same physical and chemical forms to process them more efficiently in dedicated equipment. Activity measurements are easier if the matrix is well characterized. For sorted waste of the same activity level it is easier to optimize the filling of waste containers and further treatment and conditioning processes;
- Training of operators so that they understand the consequences in downstream waste management of individual actions that produce waste.

The main area where waste minimization will be effective during NPP outage decontamination is the treatment of RAW generated. The volume of RAW resulting from decontamination operations may be reduced by processes such as compaction, incineration, filtration and evaporation. These operations will prolong the operating life of current disposal sites, limit the need for storage if disposal is not available, and reduce the number of shipments of waste.

Limiting the wastes arising from the decontamination process may result in the selection of processes other than chemical decontamination, e.g. electrochemical decontamination or ultrasounds. As stated earlier, only a detailed cost–benefit analysis can include all criteria for selecting the best option for decontamination (or selecting not to decontaminate at all).

The management of RAW arising from decontamination will be similar to that used in other segments of the nuclear fuel cycle. However, certain decontamination waste, for example, concentrated acids, will require specific consideration.

Specific consideration needs to be given to the packaging, transportation and disposal requirements. The waste forms and packages have to comply with transport regulations and with the acceptance criteria at waste disposal facilities. Ultimately the key requirement of the waste management strategy is the safety of all the waste operations.

The decontamination types that will typically apply during NPP outage include:

- FSD for dose reduction;
- Decontamination in situ/local workshop.

The treatment of waste may represent a considerable fraction of the total cost of decontamination. In some Member States there are also limitations (e.g. chelate concentrations) on the waste disposal. In some other Member States, there are no established disposal modes and the decontamination-related waste has to remain at the NPP site for long periods. In these cases, the waste volume may be a critical parameter in the decision whether decontamination is viable.

Typical example of waste that could be expected from decontamination activities during outages are liquid waste (water containing different types of chemicals), resin, filters, textile, brushes, etc.

### 7.3. LIQUID WASTE

During an outage, large amounts of different liquid waste streams could be generated, varying in activity, chemical composition, and insoluble impurities. The basic prerequisite for the efficient management of liquid wastes is the consistent sorting, collection and processing of individual waste streams.

The characteristic properties of liquid waste are different depending on which decontamination method is used and the material of the system being decontaminated. Example of content in liquid waste could be  $\text{Fe}^{2+}$ ,  $\text{Fe}^{3+}$ ,  $\text{Ni}^{3+}$ ,  $\text{Co}^{2+}$ , organic content, flammable content and this need to be considered from case to case.

Chemical, electrochemical and some mechanical decontamination methods generate radioactive liquid waste. Because the result of decontamination is concentrated activity liquid waste that is more radioactive than waste handled during normal reactor operation, new challenges may arise in liquid waste treatment, storage, solidification, and disposal. The most common processes that have been used for activity reduction in liquid waste from decontamination are filtration, reverse osmosis and ion exchanges (IX).

Current regulations in many Member States forbid the transportation of radioactive liquids offsite so rendering some form of solidification compulsory. Additionally, economic aspects suggest concentrating the liquid waste and cleaning the water for release to the environment or in-plant reuse.

Following liquid waste purification, the resulting liquids, sludge, or solids (e.g. IX media, filters, or concentrator bottoms) have to be conditioned into a waste form.

Significant savings can be achieved by establishing specific procedures and controls. As an example, consistent recirculation of water used for rinsing and decontamination of technological surfaces, consistent separation of sludge and solids arising from the heat exchanger cleaning, and consistent adherence to filling and emptying off-plant systems through propelling media are indicated.

The availability and the order of the different techniques to treat the liquid waste mentioned in following sections could be different between NPPs.

#### 7.3.1. Filtration

Filtration is done by passing the liquid through filtration materials designed to remove solids, producing a less active solution and a concentrated contaminant on the material used for filtration (if activity is absorbed onto particulate matter). Eventually the accumulation of solids on the filtration material reduces its effectiveness, and the filtration material has to be replaced or cleaned. Cleaning is commonly done by reversing the flow of water through the filtration material and diverting it to a collection tank (a process known as backwashing). This process eliminates the handling of highly radioactive cartridges or bags and thus minimizes radiation exposure of the team. Backwashing removes much of the activated corrosion products from the filter and isolates it for further treatment. The filters can be backwashed to either the reactor's RAW system or the IX system.

According to [digital.library.unt.edu](http://digital.library.unt.edu):

“Filtration can be divided into two main categories: in-depth filtration, in which the suspended matter being removed is deposited within the pores of the filter media, and surface filtration, in

which filtration takes place as a cake. Granular media filtration is an example of the former, and a cartridge-type and pre-coat filters are examples of the latter”.

Another type of filtration-like process is the membrane separation process. Filtration is typically a precursor to IX or other processes such as sludge processing and precipitation for example.

### 7.3.2. Ion exchange

IX can generally be used for removing of radioactive impurities (activity) from dilute chemical solutions. Preconditioning may be necessary with certain chemicals: for example, a permanganate solution can oxidize the organic “backbone” of the resin resulting in its breakdown, so it is necessary to reduce the permanganate to manganous ions. Both cation and anion resins are usually required: the cation resin removes most of the activity in the form of metal cations such as  $\text{Co}^{2+}$ , while the anion resin removes organic anions such as citrate and oxalate. Full removal of radionuclides on the cation resin is unlikely, since many nuclides appear as anionic species. Therefore, both cation and anion resins have to be processed as RAW.

The amounts of resins required during FSD for dose reduction can be accurately estimated on the basis of the capacity of the resin and the foreseen ionic load of the solutions, which is normally dominated by the concentration of the added reagents. Still it is prudent to provide excess resin to tackle unexpected occurrences during the decontamination, e.g. the need to add more reagent to allow for thicker oxides to dissolve. Trace metal impurities such as molybdenum, vanadium, radium and sulphate in the liquid solutions can adsorb onto resins without release thereby, reducing its functionality as described in Ref. [23].

Rather than employ a large single mixed bed column or separate single cation and anion bed, it is more common to employ many smaller IX columns that can be switched in as needed when a column becomes saturated. In some processes, a filter is placed before the IX columns. To improve flexibility, it is desirable to include a pre-column filter that can be bypassed if it blocks.

These operational features optimize resin utilization and ensure that only the minimum amount of resin is used, so contributing to the waste minimization strategy.

A typical case of IX resin management following FSD is described in Ref. [24].

In general, advantages of IX processes include:

- Good chemical, thermal and radiation stability;
- Large choice of products ensuring high selectivity.

Conversely, limitations include:

- Affected by high salt content;
- Blockage problems;
- Regeneration and recycling often difficult to employ.

Zeolites as IX have received great attention in radioactive liquid waste treatment. The cationic radionuclides present in low and intermediate level liquid wastes can be removed by the IX with the  $\text{Na}^+$  ions of the zeolites. These inorganic materials possess high exchange capacity, possible selectivity and specificity, good resistant to radiation.

Continual efforts are being made to reduce the concentration of decontamination reagents to reduce the quantities of IX resin used to clean up decontamination solutions. Another helpful

approach is the utilization of reagents in a regenerative mode using IX resin to remove active material and metal ions and to regenerate reagents for further decontamination.

All liquid waste from decontamination activities is usually processed by IX system to such levels that the water can be recycled for onsite use or transferred to the reactor's RAW system for further treatment and eventual discharge to the environment. If filters were employed during the application, the cartridges or bags are usually placed in the waste container along with the IX resin.

Initially in the USA the preferred method of disposal of spent IX resins was solidification in cement followed by disposal at a licensed waste disposal facility. However, during some resin solidifications, the mixture did not solidify satisfactorily. Although waste processing companies adjusted their formulations to mitigate the problem, dewatering of resins and direct burial in a high-integrity container (HIC) became the most cost-effective and preferred processing method in the USA.

Some IX processes are described for example in the IAEA publication Ref. [25] and in the document Ref. [26].

In lack of IX equipment more expensive ultra-filtration or solvent extraction techniques are used. However, IX is less sensitive to the volume or grade of liquor than solvent extraction.

### **7.3.3. Evaporation**

Considering that evaporator technologies are controlled by physical and chemical characteristics of the waste streams and not by their radioactivity, almost any type of evaporation technology can be applied to LLW consistent with keeping radiation exposures ALARA. Evaporators are used for treatment of large volumes of liquids, including also decontamination solutions.

When separating a solution of salts in water, the water can be vaporized from the solution without salt removal because salts are non-volatile under normal operating conditions. Loss of water by evaporation leaves behind a more concentrated solution of radioactive material (often called sludge or evaporator bottoms) thereby reducing the volume of RAW requiring disposal. The vaporized water can be condensed and reused in process applications or in many cases can be discharged. Following evaporation, the concentrated liquid or slurry waste may undergo additional drying to further reduce waste volume. Dewatering processes e.g. filter processes or centrifuges produce 'cake' (solid contents up to 60%). Process applicability has to be evaluated on a site-by-site basis.

The waste has then to be solidified, encapsulated or in some manner treated prior to disposal, and normally stored in 200 L drums prior treatment.

“The extruder-evaporator unit produces a solidified waste material, but other evaporator systems require post-evaporative treatment. It is also possible that the evaporated water may still not be of sufficient quality for direct discharge to the environment, especially if organics are present in the waste stream” [23].

General advantages of evaporators include:

- High DF > 100;
- Well established technology;
- High volume reduction factor;

- Suitable for a variety of radionuclides.

Typical issues include:

- Process limitations (scaling, foaming, volatility of certain radionuclides);
- High operation and capital costs;
- Occasional problems about evaporator corrosion and damage have been reported;
- Release of tritium and ammonia from evaporated concentrate.

Evaporation of radioactive liquid waste is an active R&D topic. For the purposes of this publication, one example will suffice, see Ref. [27].

#### **7.3.4. Sludge processing**

The primary components in the sludge formed during evaporation are undissolved solids (inert material) in water. To process the sludge, it is initially necessary to remove the water by thermal treatment (drying, vacuum drying). This is normally used when the percentage of suspended solids is high (> 60%) and the cost-benefit analysis shows that volume reduction is more efficient than direct disposal.

If thermal treatment is not available, mechanical dewatering could be considered as a pre-treatment operation. Dewatering is the packing or compressing of individual small particles into larger clumps. The most common dewatering devices are belt filter presses, plate and frame filter presses, and centrifuges. These dewatering devices can produce a solid cake of up to 60% solids and a solid capture of 90-95%.

The primary focus of the low-temperature thermal treatment (up to 150°C) is drying. The term drying encompasses chemical reactions other than water evaporation. It includes the removal of bound water (the water of crystallization). As compared to mechanical dewatering, thermal drying is more effective since it can remove all the surface water present in sludge. Thermal drying is usually more expensive than mechanical drying.

#### **7.3.5. Precipitation**

Precipitation is a general term for many processes for removing activity from liquids using techniques such as flocculation, sedimentation, co-precipitation and centrifugation. For processing of chemical decontamination solutions, reagents are added to interact with activity to form metal hydroxides as a precipitate that can be removed. In general, precipitation processes are easy to manage, inexpensive, and suitable for large volumes and high salt content waste; however, low DFs are generally achieved, and process efficiency depends on the solid-liquid separation step.

#### **7.3.6. Tritium removal**

Tritium removal from water solutions (wastewater) presents particularly a difficult problem as an isotope separation process is required. As there are no highly specific adsorbents for tritium or tritiated water, and the separation factors are so low, many separation stages are required. This makes the capital and running costs for high throughput systems very high.

The current standard technology may be the hydrophobic water-hydrogen catalytic process being employed by the Canadian nuclear programme for removing tritium from heavy water

coolant in their reactor. Special feed preparation such as demineralization, evaporation, or even electrolysis may be needed, as reported in Ref. [23].

### 7.3.7. Membrane processes

The technological maturity of suitable membrane materials has been long demonstrated in conventional water purification: later, membrane processes have been introduced to the nuclear industry as a good alternative method for treatment of liquid RAWs. Pressure driven membrane separation technologies successfully removed selective radioactive substances and have certain clear advantages over traditional processes. Typical membrane processes include reverse osmosis, ultrafiltration and microfiltration. A full review of these methods, including also design features, operating parameters, design and operational aspects, membrane performance and maintenance is given in IAEA publication Ref. [28].

Main advantages and drawbacks of membrane processes, as described in Ref. [29], are presented in TABLE 2.

TABLE 2. ADVANTAGES AND DISADVANTAGES OF MEMBRANES

Process	Advantages	Drawbacks
Reverse osmosis	<ul style="list-style-type: none"> <li>“Removes dissolved salts</li> <li>DF <math>10^2 - 10^3</math></li> <li>Economical</li> <li>Established for large scale operations</li> </ul>	<ul style="list-style-type: none"> <li>High pressure system, limited by osmotic pressure</li> <li>Non-back washable, subject to fouling</li> </ul>
Ultrafiltration	<ul style="list-style-type: none"> <li>Separation of dissolved salts from particulates and colloids</li> <li>Good chemical and radiation stability for inorganic membranes”</li> </ul>	<ul style="list-style-type: none"> <li>Fouling</li> <li>Organic membranes subject to radiation damage</li> </ul>
Microfiltration	<ul style="list-style-type: none"> <li>High recovery (99%)</li> <li>Low fouling when air backwash</li> </ul>	<ul style="list-style-type: none"> <li>Sensitive to impurities in waste stream</li> </ul>

Innovations in this field are described in Ref. [30].

## 7.4. SOLID WASTE

Solid waste is generally segregated into compactible and non-compactible, where available also as combustible forms. There are significant differences in waste acceptance criteria requirements for combustion compared to high-pressure compaction.

Solid waste can be segregated as follows:

- Specific activity of  $\alpha$ ,  $\beta$ ,  $\gamma$  radiation;
- Dose rate;
- Surface contamination;
- Mass and dimensions of waste;
- Type of solid waste;
- Hazardous materials (asbestos, organic liquids);
- Combustible and non-combustible materials.

Treatment of large solid objects as waste that is not combustible or compactible generally requires some segmentation. The extent to which segmentation is required depending on the storage capacities, transport methods, size or weight restrictions, availability of disposal containers, and availability of repository. The melting of large decontaminated objects with internal spaces (e.g. tanks) could be considered as a means of reducing the volume considerably.

Conditioned or packaged solid wastes can be disposed in a licensed disposal site, subject to waste acceptance criteria. Hazardous waste, to which ordinary disposal is normally precluded, includes material that is flammable, corrosive (e.g.  $\text{pH} < 2$  or  $\text{pH} > 12$ ), reactive, or toxic (e.g. containing heavy metals or pesticides).

#### 7.4.1. Incineration

Incineration is a very versatile process. Many devices and techniques are available that work with combustible materials in almost any physical form. In general, the following radioactive materials can be incinerated:

- Dry active waste, such as paper, plastic (but not PVC and other dioxin-producing materials), wood, cloth, rubber, fiberglass and charcoal;
- IX resins (with limited sulphur content);
- Sludge and lubricating oils (with limited heavy metal content) that have become contaminated with radioactive materials;
- High-efficiency particulate air filters.

Large pieces of metal, such as sections of pipe, cannot be incinerated, because they can jam the augers that slowly propel ashes from the charging area to the discharge area of the incinerator.

Volume reduction greater than 100 before final ash and dust immobilization and packaging are routinely realized when burning LLW: burning organic liquids (with limited tritium content) that are not contaminated with inorganic materials leaves almost no solid residue. Organic materials (e.g. plastics) are massively converted to  $\text{CO}_2$  and  $\text{H}_2\text{O}$  with essentially no production of toxic by-products. Even after final packaging, the net volume reduction is still 2 to 5 times greater than competing technologies such as super-compaction.

As a waste management strategy incineration serves several objectives:

- Destroying some hazardous materials by breaking them down into simpler chemical forms;
- Eliminating liquids in waste that otherwise complicate waste management;
- Decreasing the volume of waste.

Incineration as an alternative to direct shallow-land disposal of LLW also has the benefits of providing a waste that is readily stabilized, which minimizes long-term ground residence and leaching by rain and groundwater. Incineration operates at sufficiently high temperatures to destroy any chelated IX resins, thus eliminating the concern about the chelant limits at disposal sites.

The main disadvantage of RAW incinerator is that it produces waste residues that have much higher activity concentrations than does the original waste stream. As a result, containers of ash from the incineration of RAW may have high external dose rates and need to be shielded: also, personnel interactions with equipment and ash containers have to be minimized. Besides, original waste that would qualify for LLW disposal, after incineration could be re-classified as intermediate level waste (ILW) or high-level waste (HLW) and thus be unacceptable for

shallow land disposal. This incineration residue will be stored in suitable containers awaiting a national repository for ILW/HLW. Another drawback for incinerator operation is that materials such as iron and concrete debris have to be removed from combustible waste.

The emerging plasma technology may be suitable for treatment of problematic chemical waste (such as some resulting from decontamination). The first full-scale industrial plant for treatment of radioactive LLW started up in early 2004 (the ZWILAG plant in Switzerland). A demonstration test run of the plasma melting facility at the Kozloduy NPP, Bulgaria was completed in late 2017. The facility will be used to treat low- and intermediate-level solid RAW, as shown in Ref. [31].

Because of its extremely high temperatures (up to 10,000°C) plasma can treat any radioactive material with no need for pre-treatment or pre-sorting. The inorganic materials are melted into a glassy slag containing most activity (incl. Co, U, and most of the semi-volatile <sup>137</sup>Cs), while the organic materials are vaporized into a synthesis gas and then oxidized in an afterburner (see Ref. [18] and IAEA publication for incinerators [32]).

#### **7.4.2. Compaction**

Compaction is one of the simplest and most effective techniques for reducing the volume of dry solid radioactive waste. Compactors are simple to operate, and available in various designs, forms and sizes. Compaction is a process by which material is physically compressed into a smaller volume. It does not change the composition of the solids or reduce the mass during the increasing densification of the waste. Compacted waste can be compacted into a 200 L drum, steel box, or other container, depending on the design of the compactor.

Conventional low-pressure compactors compact waste directly into 60 or 200 L drums, exerting forces of 10 t and more. Box compactors can accept larger objects and developing compressive forces up to 250 t. Their rectangular-shaped containers also utilize space more efficiently than conventional compactors, resulting in larger volume reduction. Super-compactors can exert forces greater than 1000 t compressing entire waste drums. Consequently, they can accept and compact nearly all dry active waste including metal components that fit into the disposal container.

The volume reduction achieved by a compactor depends on the applied force, the bulk density of the waste material, and the spring-back characteristic of the material when compaction pressure is released. This technology is described in Ref. [18].

## **8. CONCLUSIONS**

Decontamination is by definition the complete or partial removal of contamination from surfaces by a deliberate mechanical, physical, chemical or biological process. Sometimes, it can also concern the removal of radioactivity situated deeper in the material (mostly for concrete). There are many varied types of decontamination that can be performed during outages, from single component to full system.

There are also routine decontamination activities which could be defined as those activities occurring repeatedly during a plant lifetime due to maintenance and or inspection requirements of the NPP. In addition, there are non-routine decontamination activities which could be



defined as those occurring infrequently during a plant lifetime requiring a specific intervention needing specific planning, engineering, equipment and application processes.

Direct and indirect costs of decontamination should be assessed in the cost-benefit analysis intended to agree to the need of decontamination and to a specific decontamination method. A generic form of the cost-benefit assessment includes monetary and nonmonetary terms, and its complexity may well require a multi-attribute analysis (MAA). The overall dose and financial benefits should be estimated to determine whether the decontamination process justifies its cost.

Decontamination methods selected should be compatible with reactor materials and should produce the most effective decontamination without undue corrosion or recontamination of those areas treated. This process should be done safely, within regulatory guidelines, at an acceptable cost, with a minimum duration, and with minimum radiation or chemical risks to the workers involved in the decontamination. Provisions to address unexpected situations should be part of the planning.

The efficiency of different decontamination processes must be evaluated beforehand to select the most suitable to the NPP in question and the most common parameter for a preliminary evaluation is the DF.

There are actions to help mitigate recontamination after decontamination, but there is no guarantee that the recontamination rate will be reduced with specific actions, but it could be worth spending some extra time and money to evaluate them.

Workers performing activities in the radiation-controlled area should meet the requirements resulting from applicable legislation

Decontamination operations may span over an NPP service life and because of this the role of records is crucial.

The planning of decontamination activities is essential for the decontamination performed and must be adapted to the reactor in question and to the specific need. Main activities such as dose planning, training program, selection of technologies, cost estimation and logistics have to be considered before starting the decontamination activities.

Waste minimization from decontamination activities is important as it can have a high impact on the budget of a station and lead to scrutiny from the public domain if unnecessary waste is deposited into the environment. With these two factors, it is important to incorporate waste minimization into NPP decontamination techniques.

Plant design, processing cost, worker radiological exposure, and allowable final disposition forms are all inputs into the waste minimization equation. Using these inputs along with industry experience a solid rad-waste minimization plan will need to be constructed prior to decontamination activities so that a reduction plan can be incorporated into the overall decontamination project plan.

Decontamination operations may span over an NPP operational period of at least 40 years (currently extended in some Member States to 60+ years). As outages are frequent events in an NPP lifetime, it is imperative to ensure that the knowledge acquired during previous decontamination operations will not be lost but will be forwarded on along a line of experienced implementers (reactor personnel and contractors). Properly conducted succession planning (incl. briefing / debriefing sessions etc.) is intended to prevent the loss of knowledge. Record management is also a key component of this assurance. In fact, the broader knowledge management includes record-keeping, human resources, technical competence management, primary and continuing education, stakeholder involvement, organizational and managerial schemes etc.

DFs in some chemical processes may be reasonably high but the continuing contact of contaminated solutions with the newly cleaned surfaces may re-deposit contamination, resulting in limited or no reduction of general dose rates.

Reducing the source term of such radioactive nuclides as Co, Ag and Sb is probably the most effective (but most expensive) means of mitigating recontamination after decontamination. But there are also other ways to this end. For example, passivation of system surfaces is one option to prevent recontamination. Zinc injection is used by many NPPs to mitigate  $^{60}\text{Co}$  build-up on primary system surfaces. The choice of chemistry, including pH, hydrogen injection, noble metal injection and also operation parameters such as flow rates, temperature and pressure is meant to reduce the activity build-up before and after decontamination.

Not unlike other segments of the nuclear fuel cycle, the challenges and costs of each step of radioactive waste management during decontamination (treatment, conditioning, packaging, storage, transportation and disposal), the radiation exposure of the workers and the public, and the contamination of the working environment, all depend on the volumes of the waste generated. Waste management may represent a considerable fraction of the total cost of decontamination.

During an outage, large amounts of different liquid waste streams arise, varying in activity, chemical composition, and insoluble impurities. In addition, chemical, electrochemical and mechanical decontamination methods generate secondary radioactive waste. Management methods for all types of waste are generally available but it is essential that they are identified and as needed tested before application.

Detailed consideration needs also to be given to the types of solid waste and to the packaging, transportation, storage and disposal requirements.

In addition to available techniques, administrative controls play a significant role in the waste minimization strategy during outage and decontamination.

The volume of radioactive waste resulting from decontamination operations may be reduced by processes such as compaction, incineration and evaporation. Limiting the waste arising from the decontamination may lead to the selection of processes other than chemical decontamination, e.g. electro-chemical or ultrasonic processes.

Over the years, nuclear power plant operators have adopted new decontamination techniques or improved existing ones mostly to reduce radiation exposures during shutdowns, and maintenance and inspection activities during subsequent plant operation. These efforts have produced a large amount of information which is the basis of this publication.

Furthermore, economic constraints made more and more clear that decontamination activities during outages should be consistent with the planned duration, schedule and constraints of the outage and minimize any delays to the planned restart of the reactor. Experience also showed that, while decontamination produces radiological and economic benefits, it cannot be undertaken without consideration of its disadvantages including e.g. extra doses, generation and management of secondary waste, and costs. Therefore, the decision of undertaking decontamination and the selection of decontamination processes is inherently subject to some form of cost-benefit analysis.

This publication reviews the current state-of-the-art in decontamination technology including radiological and organizational planning/preparation, as well as the deposition of radionuclides during NPP operation, and design/operational measures to minimize the build-up of contamination and recontamination.



## REFERENCES

- [1] UKAEA, Best Practicable Environmental Option Study for Management of Radioactive Waste Arisings from the Dounreay Site Restoration Plan, UKAEA (2003).
- [2] GORSCHBOTH, F., HAMILTON, M., An Evaluation of the Cost/Benefits of Concrete Biodecontamination, INEEL/EXT-98-00780, US DOE (1998).
- [3] INTERNATIONAL ATOMIC ENERGY AGENCY, Deterministic Safety Analysis for Nuclear Power Plants, IAEA Safety Standards Series No. SSG-2, IAEA, Vienna (2009).
- [4] INTERNATIONAL ATOMIC ENERGY AGENCY, Predisposal Management of Radioactive Waste from Nuclear Power Plants and Research Reactors, IAEA Safety Standards Series No. SSG-40, IAEA, Vienna (2016) 83 pp.
- [5] INTERNATIONAL ATOMIC ENERGY AGENCY, Predisposal Management of Radioactive Waste, IAEA Safety Standards Series No. GSR Part 5, IAEA, Vienna (2009).
- [6] INTERNATIONAL ATOMIC ENERGY AGENCY, Safety Assessment for Facilities and Activities, IAEA Safety Standards Series No. GSR Part 4 (Rev. 1), IAEA, Vienna (2016).
- [7] INTERNATIONAL ATOMIC ENERGY AGENCY, Industrial Involvement to Support a National Nuclear Power Programme, Nuclear Energy Series No. NG-T-3.4, IAEA, Vienna (2016) 66 pp.
- [8] INTERNATIONAL ATOMIC ENERGY AGENCY, Radiation Protection and Safety of Radiation Sources: International Basic Safety Standards, Safety Standards Series No. GSR Part 3, IAEA, Vienna (2014) 436 pp.
- [9] INTERNATIONAL ATOMIC ENERGY AGENCY, Industrial Safety Guidelines for Nuclear Facilities, IAEA Nuclear Energy Series No. NP-T-3.3, IAEA, Vienna (2018) 87 pp.
- [10] UNITED DEPARTMENT OF LABOR, Occupational Exposure to Hazardous Chemicals in Laboratories, Occupational Safety and Health Standards 1910.1450, US DOL.
- [11] ICRP, General Principles for the Radiation Protection of Workers, ICRP Publication 75. Ann. ICRP 27, ICRP (1997).
- [12] EURATOM, Basic Safety Standards for Protection against the Dangers Arising from Exposure to Ionising Radiation, Council Directive 2013/59/EURATOM, EURATOM (2013).
- [13] INTERNATIONAL ATOMIC ENERGY AGENCY, Occupational Radiation Protection, IAEA Safety Standards Series No. GSG-7, IAEA, Vienna (2018).
- [14] ISOE Network - ISOE Annual report - 2017, Information System on Occupational Exposure (2019).
- [15] INTERNATIONAL ATOMIC ENERGY AGENCY, Planning, Managing and Organizing the Decommissioning of Nuclear Facilities: Lessons Learned, IAEA-TECDOC-1394, IAEA, Vienna (2004).

- [16] INTERNATIONAL ATOMIC ENERGY AGENCY, IAEA Safety Glossary Terminology Used in Nuclear Safety and Radiation Protection, 2018 Edition, Non-serial Publications, IAEA, Vienna (2019) 261 pp.
- [17] KAUL, A., BECKER, D., BRIX, G., DALHEIMER, A., Landolt-Börnstein Group VIII: Advanced Materials and Technologies Volume 4 Radiological Protection, Numerical Data and Functional Relationships in Science and Technology, Springer Verlag, Berlin (2005) 20 pp.
- [18] OJOVAN, M., Handbook of Advanced Radioactive Waste Conditioning Technologies, Woodhead Publishing Ltd (2011) 512 pp.
- [19] GOWIN, P., KINKER, J., KOSILOV, A., UPSHALL, I., YANEV, Y., Knowledge Management for Radioactive Waste Management Organisations, Woodhead Publishing Ltd (2009).
- [20] INTERNATIONAL ATOMIC ENERGY AGENCY, Handling and Processing of Radioactive Waste from Nuclear Applications, Technical Reports Series No. 402, IAEA, Vienna (2001) 143 pp.
- [21] INTERNATIONAL ATOMIC ENERGY AGENCY, Innovative Waste Treatment and Conditioning Technologies at Nuclear Power Plants, TECDOC Series No. 1504, IAEA, Vienna (2006).
- [22] INTERNATIONAL ATOMIC ENERGY AGENCY, Methods for the Minimization of Radioactive Waste from Decontamination and Decommissioning of Nuclear Facilities, Technical Reports Series No. 401, IAEA, Vienna (2001) 157 pp.
- [23] NOYES, R., Nuclear Waste Cleanup Technology and Opportunities, William Andrew Inc. (1995) 471 pp.
- [24] SATO, Y., SUZUKI, N., WILLE, H., FULL SYSTEM DECONTAMINATION FOR DOSE REDUCTION AT THE PREVENTIVE MAINTENANCE WORK OF THE REACTOR CORE INTERNALS, International Nuclear Information System, Vienna (1999).
- [25] INTERNATIONAL ATOMIC ENERGY AGENCY, Application of Ion Exchange Processes for the Treatment of Radioactive Waste and Management of Spent Ion Exchangers, Technical Report Series No 408, IAEA, Vienna (2002) 115 pp.
- [26] REHAB O. ABDEL RAHMAN, H.F. ALI, A. M. EL KAMASH, YUNG-TSE HUNG, Overview on Recent Trends and Developments in Radioactive Liquid Waste Treatment Part 1: Sorption/Ion Exchange Technique, (2011).
- [27] LU, J., ZHOU, Y., Process Design of Heat Pump Evaporation Technology for Liquid Radioactive Waste Treatment, Conference paper at ICONE 25, Shanghai, China (2017).
- [28] INTERNATIONAL ATOMIC ENERGY AGENCY, Application of Membrane Technologies for Liquid Radioactive Waste Processing, Technical Report Series, Vol. No 431, IAEA, Vienna (2004) 145 pp.
- [29] ABDEL RAHMAN, R.O., IBRAHIUM, H.A., HUNG, Y.T., Liquid Radioactive Wastes Treatment: A Review, ISSN 2073-4441, (2011).

- [30] ZAKRZEWSKA-TRZNADEL, G., Advances in Membrane Technologies for the Treatment of Liquid Radioactive Waste, (2013).
- [31] Bulgarian waste treatment facility testing completed, WNN, <http://www.world-nuclear-news.org/WR-Bulgarian-waste-treatment-facility-testing-completed-3011174.html> (2017).
- [32] INTERNATIONAL ATOMIC ENERGY AGENCY, Design and Operation of Radioactive Waste Incineration Facilities, Safety Series No 108, IAEA, Vienna (1992).
- [33] INTERNATIONAL ATOMIC ENERGY AGENCY, Radioactive Waste Management Glossary, 2003 Edition, IAEA, Vienna (2003).
- [34] POINT BEACH NUCLEAR PLANT, Exclusion of Foreign Material from Plant Components and Systems, Procedures manual NP 8.4.10, Point Beach Nuclear Plant (2004).



## ANNEX I. INTERNATIONAL CASE STUDIES

The examples provided in the following pages address the organization and detailed technical aspects of NPP outage decontamination. The descriptions can be useful to provide practical information on how such projects are planned and managed in various Member States. The examples given are not necessarily best practices. Rather, they reflect a variety of international practices. Readers are invited to assess the applicability of the annexes below to the projects of their concern. These national annexes reflect the experience and views of their contributors and, although generally consistent with the main text, are not for guidance. Of course, the information presented is not intended to be exhaustive.

### I-1. CZECH CASE STUDIES

Permission to reproduce is the courtesy of Kopecky, P., CEZ, Czech Rep.

#### **I-1.1. Steam generator's decontamination at Dukovany NPP with AP-Citrox method**

##### *I-1.1.1. Context*

The Dukovany nuclear power plant was put into operation in 1985-1987. These are 4 units of WWER-440 reactor type. The specific feature of the WWER-440 design is six reactor cooling loops, that means each reactor is connected to six circulating pumps and six steam generators (SGs).

Equipment DEKOZ PG, as shown in Figure I-1, was designed for the chemical decontamination of the SGs of the plant. It separates the primary part of SG from the remaining part of the reactor cooling loop, serves for filling and draining the decontamination solutions into and from SG separated section and ensures also their circulation. Used decontamination solutions are drained by compressed air from the SG into the liquid waste draining lines. The device does not allow the recovery of the used decontamination solutions.



## STEAM GENERATOR DECONTAMINATION EQUIPMENT

- 1 Lower part
- 2 Upper part
- 3 Flange
- 4 Support
- 5 Electric motor
- 6 Propeller
- 7 Shaft
- 8 Control rod
- 9 Sliding segments
- 10 Plug
- 11 Control rod
- 12 Outlet
- 13 Support structure
- 14 Flange
- 15 Distribution unit
- 16 Expansion vessel
- 17 Revolving rod
- 18 Level indicator
- 19 Thermometer
- 20 Sample take out
- 21 Deaeration
- 22 Level indicator
- 23 Pressure indicator
- 24 Metallic ring
- 25 O ring
- 26 Rubber gasket

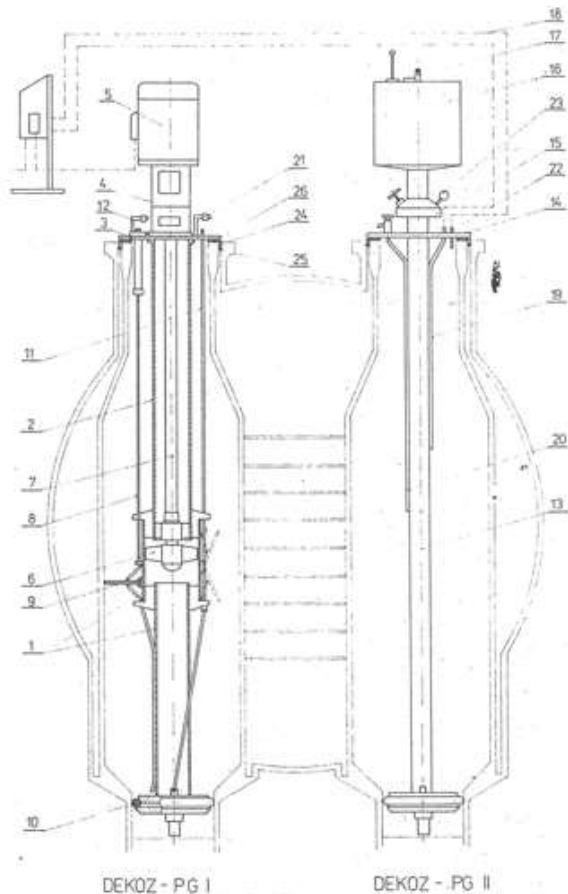

FIG. I-1. Equipment DEKOZ PG from CEZ a.s., Dukovany NPP.

Reproduced from CEZ a.s., Dukovany NPP Operational instruction k004j- Decontamination SG with permission.

### I-1.1.2. Need for steam generators' decontamination

In the years 1988-1992, leaks of heat-exchanging tubes of the SGs were identified. Due to lack of remote-controlled equipment, presence of workers was required inside the steam generator collectors. The radiation situation that faced workers led to carry out the decontamination of SGs.

The bulk of the SG's decontamination (see equipment used in the Figure I-2) was carried in 1993-1996 for the feed water distribution piping (see Figure I-3) replacement project.



*FIG. I-2. Decontamination equipment from CEZ a.s., Dukovany NPP.  
Reproduced from Intranet CEZ a.s., Dukovany NPP with permission.*



*FIG. I-3. Feed water distribution piping from CEZ a.s., Dukovany NPP.  
Reproduced from Intranet CEZ a.s., Dukovany NPP with permission.*

The time-consuming activities performed inside the secondary part of SG could not be ensured without decontamination. Twenty-four SGs have been then decontaminated, some of them repeatedly. Extensive decontaminations of SGs appeared necessary because of significant recontamination (see the dose rates in Figure I-4).

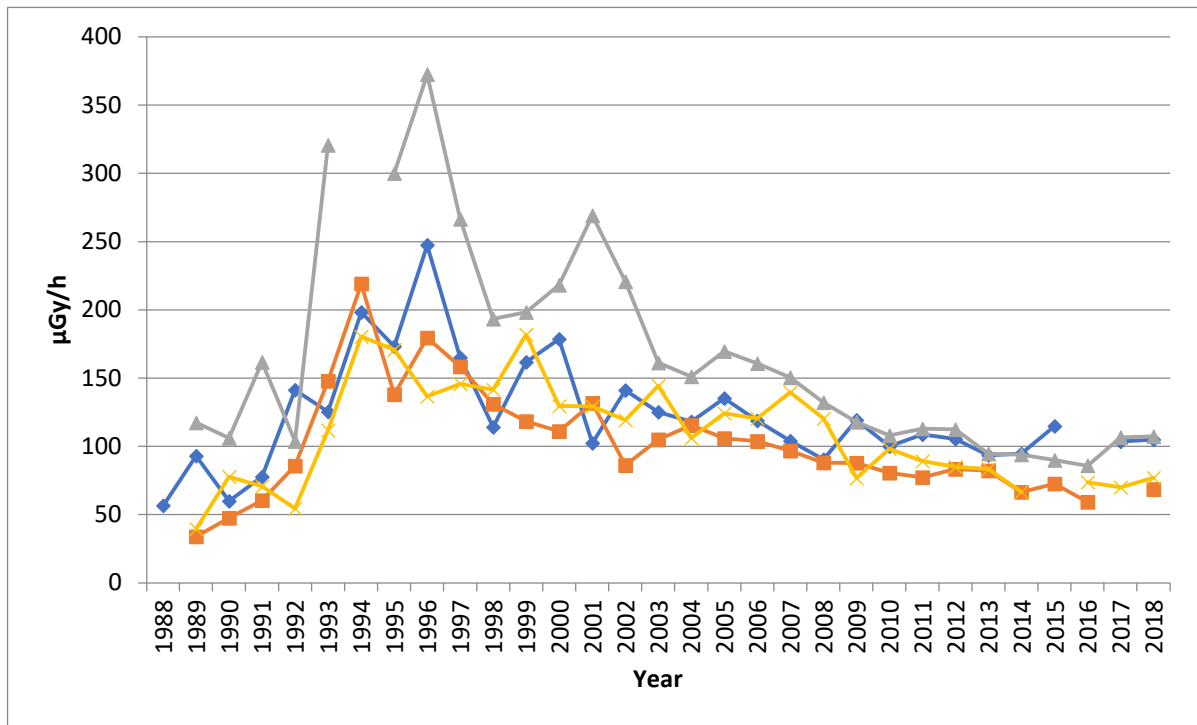

FIG. I-4. Average dose rates at reference points of the reactor coolant circulation loops after reactor shut down (units 1 to 4).

Reproduced from CEZ a.s., Dukovany NPP, Radiation Protection Department data, 2018 with permission.

In the period 1999-2005 three SGs were decontaminated before replacement of the upper part of the SG's collector (indications on the flange in the thread holes). Consequently, the maintenance activities inside the SG's collectors were minimized; remote-controlled tools were used (cutting, welding, eddy current testing).

Based on experience collected during decontamination of more than thirty SGs, it was decided to stop the chemical decontamination of SGs and prefer alternative methods for reducing the radiation doses to the personnel during SG repair and maintenance.

#### I-1.1.3. Summary

Thirty-four SGs were chemically decontaminated between 1988 and 2005. All decontaminations were performed by NPP's staff. Generated liquid waste was evaporated and processed (bituminized) on site.

The main reasons for SG chemical decontamination were:

- Material testing and plugging of damaged SG heat exchange tubes;
- Extensive modification of the feed water distribution pipelines on the secondary part of all twenty-four SGs;
- Replacement of SG primary collector main flanges, (failed thread holes).

The main advantages of SG decontamination were:

- Reduction of collective effective dose by 60-80 mSv per SG;
- Fulfilling the requirement to reduce the dose rate below 4mGy/h;

- No ILW was generated;
- Liquid RAW is processable by the technology available at the NPP.

The results of the performed SG decontamination are listed in Table I-1.

TABLE I-1. SG DECONTAMINATION SUMMARY DATA

	Min	Max	Unit
Duration of process	67	175	hour
Decontamination cycles	1	3	
Process	AP/Citrox	AP/Citrox	
Volume of liquid waste *	70	150	m <sup>3</sup>
Activity removed*	1.2E+12	8.9E+12	Bq
Dose rate at the hot leg	2.2	27	mGy/h
Dose rate at the cold leg	2.1	28.3	mGy/h
DF at the hot leg	1.8	14.3	
DF at the cold leg	1.6	35	
Estimated mass of removed material*	11.3	28.2	kg
Collective effective doses (decontamination staff)	1.2	4.7	mSv

The disadvantages of SG decontamination were:

- Volume of generated liquid RAW;
- Duration of decontamination process;
- Impact on the surface of the SG construction material;
- Radioactive sludge remaining in the heat exchange tubes.

#### *I-1.1.4. Lessons learned*

Chemical decontamination of SGs is an effective means of reducing the radiation doses of personnel performing maintenance activities inside SGs. At the same time, SG chemical decontamination is a source of significant risks in relation to reactor cooling loop materials, subsequent recontamination and RAW production. Based on the assessment of the results of the decontamination of thirty-four SGs, Dukovany NPP decided to reduce SG's chemical decontamination.

Alternative methods (chemical treatment modification, shielding, remote controlled devices, etc.) are now preferred.

### **I-1.2. Ultrasonic decontamination at Dukovany NPP**

#### *I-1.2.1. Basics of ultrasonic decontamination*

Ultrasonic cleaning has been widely used in the industry.

---

\* Values estimated in liquid phase (spent decontamination solutions)

Ultrasonic cleaning combines the effects of cavitation of a liquid at the surface to be cleaned with the chemical action of liquid. Cavitation can be induced in a liquid by vibration producing a high localized pressure and temperature. Cavitation occurs at a metal-liquid interface and also on the surfaces of holes, crevices and internal surfaces.

An ultrasonic cleaner generally includes the following components:

- Ultrasonic generator – (converts normal 50Hz power frequency to a high frequency 20-40 kHz or higher);
- Transducer (vibrator) - contains piezoelectric or magnetostrictive elements;
- Stainless steel tank;
- Heater;
- Control panel;
- Baskets - small items can be immersed in the liquid for cleaning by placing them in a basket.

Ultrasonic decontamination has been used successfully to decontaminate a variety of items in several nuclear plants.

#### *I-1.2.2. Limitations of ultrasonic decontamination*

The limitations are usually the following:

- Temperature of decontamination solution < 80°C;
- Limited effectiveness in removing tightly adherent material;
- Limited effectiveness in decontamination of plastic, energy absorbing, materials such as rubber, silicon;
- Maximum distance of transducer from decontaminated surface approx. 0,5m.

#### *I-1.2.3. Implementation at Dukovany NPP*

The equipment used at Dukovany NPP is shown in Figure I-5.



*FIG. I-5. . Ultrasonic decontamination bath with transducers CEZ a.s., Dukovany NPP.*

*Reproduced from CEZ a.s., Dukovany NPP Operational instruction K097j-Ultrasonic decontamination tank with permission.*

The characteristics of the ultrasonic decontamination bath are listed in Table I-2.

TABLE I-2. CHARACTERISTICS OF ULTRASONIC DECONTAMINATION BATH

Characteristic	Value
Geometric volume	3,5 m <sup>3</sup>
Working temperature	50°C
Internal dimensions	1,6x1,6x1,5m
Voltage	220V
Max. electrical input	2000W
Transducers frequency	40kHz
Number of transducers	18
Total effective output	18kW
Max dimensions of item	1,4x1,4x1,2 m
Max weight of item	1500kg

### I-1.3. Electrochemical decontamination at Dukovany NPP

#### I-1.3.1. Basics of electrochemical decontamination

Electrochemical decontamination is a rapid and effective technique for removal of radionuclides from metallic surfaces. The decontaminated object is immersed in a tank of electrolyte and serves as the anode in an electrolytic cell. The passage of electric current results in the anodic dissolution of surface material. The material removed during electropolishing remains in the electrolyte. The electrolyte is replaced when effectiveness of decontamination drops down.

Major components of electrochemical decontamination system are the following:

- DC power supply converts alternating current to direct current;
- Voltage requirements range: 0–24V with required sufficient power density;
- Amperage requirements: in case of immersion electropolishing power supply amperage capacities are > 2000 A;
- Stainless steel tank;
- Cathodes made of stainless steel or titanium;
- Ventilation system to control the release of aerosols from decontamination tank during electropolishing;
- Electric cables.

Electrolyte volumes used for decontamination are relatively low compared to those for chemical decontamination.

The equipment used for electrochemical decontamination at Dukovany NPP is presented in Figure I-6.



FIG. I-6. Electrochemical decontamination bath CEZ a.s., Dukovany NPP.

Reproduced from CEZ a.s., Dukovany NPP Operational instruction K097j- Electrochemical decontamination tank with permission.

The characteristics of the electrochemical decontamination bath are listed in Table I-3.

TABLE I-3. CHARACTERISTICS OF ELECTROCHEMICAL DECONTAMINATION BATH

Characteristic	Value
Usable volume	2,2m <sup>3</sup>
Working temperature	50°C
Internal dimensions	1,4x1,4x1,2m
Current density	100mA/cm <sup>2</sup>
Max. Voltage	25V
Max. Amperage	2000A
Electrical input	50kVA

#### I-1.3.2. Limitations of electrochemical decontamination

DFs up to 500 or more are often achieved by this method. However, the effectiveness of electrochemical decontamination can be limited by foreign materials on the surface of items to be decontaminated (oil, grease, rust and other coatings).

Decontamination of large components may be limited by the capacity of the decontamination tank. The electrolyte has to be completely rinsed before use.

#### I-1.3.3. Lessons learned both from ultrasonic and electrochemical decontamination

Czech NPPs have been using ultrasonic and electrochemical decontamination for more than fifteen years. These technologies contributed significantly to reducing the volume of RAW and increased the efficiency of decontamination.

After implementing these technologies at Dukovany NPP, the volume of liquid RAW was reduced by 70-80%, compared with chemical decontamination. For solid RAW, the waste volume was reduced by 50-60%.

Thus, the introduction of these technologies has contributed significantly to increasing the efficiency of decontamination of contaminated materials before releasing into the environment.

## I-2. FRENCH CASE STUDY AT EDF

Permission to reproduce is the courtesy of Rocher, A., EDF, France.

### I-2.1. RHRS/CVCS circuit decontamination

#### I-2.1.1. Overview of EDF's radiological surveillance program

The radiological surveillance program of French NPPs is based on the monitoring of 3 indices, measured at the beginning of refuelling outages. These indices are used to mark the radiological level of the circuits.

- The loop index represents the overall state of the primary circuit contamination;
- The reactor building (RB) index shows the contamination state of RB and auxiliary circuits;
- The so-called 'Cd-Zn-Te gamma spectrometry' allows to define the origin of the contamination:  $^{60}\text{Co}$ ,  $^{110\text{m}}\text{Ag}$ , etc. It also helps select the chemical process to be implemented for decontamination if needed.

These three indices are specified in Table I-4. They are measured under the same conditions in each French NPP.

TABLE I-4. INDICES OF CONTAMINATION MEASURED IN FRENCH NPPs

	Loop index (Dose rate)	RB index and sub-indices (Dose rate)	Cd-Zn-Te gamma spectrometry
Where	Legs: hot, cold and crossover 9 or 12 pts: loops	At different RB levels 46 to 50 RB measurement points	3 pts CVCS + 3 RCS + 1 SIS + 1 RHRS Total of 8 pts: RCS, CVCS, RHRS & SIS
When	12 to 16 hours after shutdown	After permission of entry into the RB	Before and after oxygenation
From	1st cycle of Fessenheim NPP prescribed since the beginning of the operations	Since 2010 for few units Prescribed since 2011	Since 2006 for few units in addition to the DR indices Prescribed since 2011
Why	Overall primary circuit contamination Primary loops radioactive state	RB and auxiliary circuits radiological states/contamination	Radiological characterization of the circuits
Stakes	Temporal evolution of the primary circuit contamination Helps decide to perform Zn injection and/or implementation of tool for biological shielding	Temporal evolution of RB and auxiliary circuits contamination Helps decide to decontaminate and/or to implement tools for biological shielding Helps remove hot spots	Radiological characterization of dose rates and indication of presence of pollutants Helps select the decontamination method for RHRS/CVCS circuits



More precisely:

- Loop index is calculated from the dose rate measurements around the primary pipes. The location of the contact dose rates is perfectly identified: hot legs, crossover legs and cold legs of the primary circuit. These measurements have to be taken just at the beginning of the reactor shutdown, between 12 and 16 hours after the reactor shutdown, when the primary fluid volume activity is not too high (lower than 1 GBq/Ton) in order to avoid misinterpretation. The loop index represents mainly the state of the loop contamination and the overall primary circuit itself;
- RB index has been specified since 2011 to evaluate the auxiliary circuit contamination and to early identify an over-contamination. It is measured at the beginning of the shutdown before oxygenation. Sub-indices can be calculated to assess the radiological state of a particular circuit if needed;
- Cd-Zn-Te gamma spectrometry measurements describe the activated corrosion product contribution to the dose rates at different circuit locations. It may allow an early detection of specific contamination and could help choose the appropriate decontamination process, depending on the nature and the half-life of the radionuclide ( $^{60}\text{Co}$ ,  $^{58}\text{Co}$ ,  $^{110\text{m}}\text{Ag}$ , etc.).

#### *I-2.1.2. RHRS/CVCS circuit decontamination*

The EDF strategy consists in decontaminating only the RHRS and CVCS circuits. Based on the radiological surveillance program described earlier, a multi-annual plan for decontamination is proposed. It aims at reducing dose rates of the highest dose circuits to bring them back to the average dose rates of the nuclear units of their series (900MW, 1300MW, 1400MW).

#### *I-2.1.3. Initial methodology*

The initial methodology of decontamination consisted in identifying units with significantly higher radiological indices compared to the average of their series. In a first step, the radiological indices are considered significantly high when they are greater than 25% of the mean of the series. Regarding circuits' decontamination plan at EDF, only the indices RHRS and CVCS indices are taken into consideration.

Thus, the units with the highest indices are identified. Appropriate actions are taken to bring them back to the average of the series, depending on the affected circuits and the nature of the contamination ( $^{60}\text{Co}$ ,  $^{110\text{m}}\text{Ag}$ , etc.)

Feedback has shown certain limits of the initial methodology:

- RHRS and CVCS indices can vary each year, which may lead to a re-evaluation of the ongoing decontamination programme;
- The main maintenance tasks on the RHRS and CVCS circuits are not taken into account in the preparation of the decontamination schedule.

#### *I-2.1.4. New methodology*

Therefore, a new methodology has been developed. This new methodology considers the number of RHRS/CVCS indices calculated over the last four years. It allows a consolidation of these indices, and the maintenance program focuses on RHRS and CVCS circuits for five years after the decontamination. Thus, it allows to optimize the RHRS/CVCS decontamination date, prior to major maintenance activities, in order to

increase the dose savings after decontamination. This methodology breaks down into two successive stages.

The first stage reinforces the choice of eligible units for decontamination. It consists of the consolidation of the RHRS/CVCS indices, considering the indices calculated over 4 rolling years. A unit becomes eligible for decontamination from 2 high indices out of 8 (4 indices for the RHRS and 4 for the CVCS), as shown in the Figure I-7).

Year	Index RHRS				Index CVCS			
	N	N + 1	N + 2	N + 3	N	N + 1	N + 2	N + 3
Unit A								

FIG. I-7. Selection of eligible units based on the number of RHRS and CVCS high indices.

In the example described in the Figure I-7, Unit A becomes eligible for RHRS/CVCS decontamination because of its 5 high indices (2 for RHRS and 3 for CVCS).

When a unit is eligible for decontamination, it is necessary to conduct a complementary study. This study consists of the realization of a specific cartography of the most polluted circuits to determine more precisely the dose savings for the 5 years after the decontamination. The dose savings will also depend on the number of hours worked in the controlled area during this period. Finally, the dose savings are monetarily valued and compared to the cost of achieving decontamination by a contractor. At the end of the study, if the ratio (dose saving/cost of decontamination) is positive, the unit will be decontaminated. Otherwise the unit will not be decontaminated.

The second stage consists in considering the year of the main RHRS/CVCS maintenance activities for the five years following the decontamination, i.e. material replacements and hydrostatic tests. Information relating to indices and maintenance operations before decontamination appears in Figure I-8.

RHRS/CVCS high indices			Number of main maintenance activities				Product of high indices by number of activities			
RHRS	CVCS	Total	2019	2020	2021	2022	2019	2020	2021	2022
2	3	5	1	2	2	2	5	Refuelling outage	10	Refuelling outage

FIG. I-8. RHRS & CVCS maintenance activities - 5 years after decontamination

The table shown in Figure I-8 is a dynamic tool calculating the weight of the high index number and the number of maintenance operations on the RHRS/CVCS circuits within five years after decontamination. This weight is used to determine the optimal year for decontamination. In the example, the unit is eligible for decontamination and the optimal year for decontamination is 2021.

To establish the multi-year RHRS/CVCS decontamination plan for the whole nuclear fleet, following parameters have to be considered: type of outage (refuelling, standard, decennial),

planning of outage, and maximum number of possible decontaminations per year due to the allocated budget.

As a result, the estimated collective dose saved at EDF by the decontamination of RHRS/CVCS circuits is comprised between 200 and 800 man.mSv over 5 years.

## I-2.2. Decontamination of reactor cavity and spent fuel pool (SFP)

### I-2.2.1. Overview

The reactor cavity is used during cold shutdowns for refuelling to perform fuel handling or maintenance operations. The walls and floors of the reactor cavity are contaminated during the unloading and reloading of the fuel. This contamination comes from the fuel deposits and contaminating species of the primary fluid as  $^{58}\text{Co}$ ,  $^{60}\text{Co}$ ,  $^{59}\text{Fe}$ ,  $^{54}\text{Mn}$ , etc.

This contamination is deposited on the surfaces and is rather labile. However, the operator often mentions a phenomenon of contamination re-emergence after decontamination and drying of the reactor cavity surfaces. This contamination is then most likely related to the porosities and roughness of the surfaces. It is then more fixed and less easy to eliminate. In addition, a greasy aspect of the contamination (less labile appearance) is often evoked by the decontaminants.

Whatever the decontamination process used, it comprises both a phase of chemical decontamination by applying foam and a mechanical decontamination phase by using a high-pressure cleaner, a squeegee and wipes.

During refuelling outage (short outage) or maintenance outage (standard outage), two decontaminations of the reactor cavity are systematically implemented (see Figure I-9):

- Intermediate decontamination after unloading;
- Final decontamination after reloading.

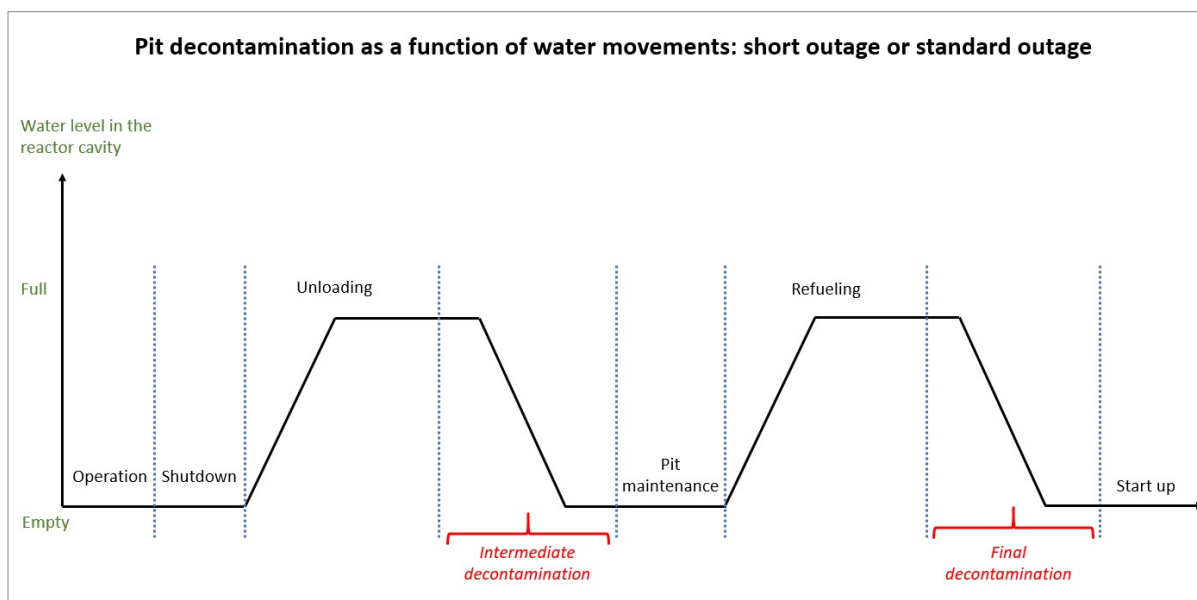

FIG. I-9. Pit decontamination as a function of water movements: short outage or standard outage.

During a decennial outage, three decontaminations are systematically implemented (see Figure I-10):

- Decontamination before hydrostatic test after unloading;
- Decontamination before containment building pressure test;
- Final decontamination after reloading.

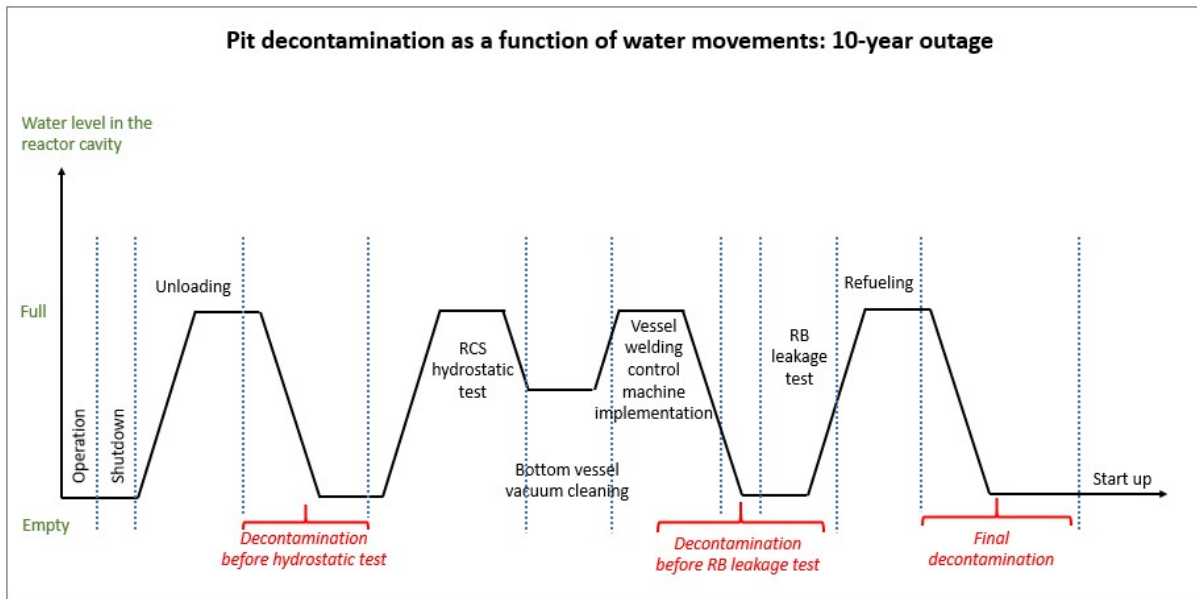

FIG. I-10. Pit decontamination as a function of water movements: 10-year outage.

#### I-2.2.2. Intermediate decontamination after unloading

The objective of intermediate decontamination is to reduce the dose rates at the bottom of the reactor cavity to lower workers' exposure. This decontamination does not affect the critical path of the outage, but it is recommended to plan sufficient length of the outage to perform this operation. At the end of the decontamination, following equivalent dose rates have to be reached:

- Ambient dose rate (DR) < 2 mSv / h; Ambient DR < Ambient DR from the previous outage;
- Ambient DR mappings are made from measurement points. The result taken is the average of these points.

The activities implemented for intermediate decontamination are as follows:

- Implementation of fine filters (strainers) at the bottom of reactor cavities;
- Vacuuming underwater to eliminate hot spots (oxides that come off the fuel when handling assemblies);
- Commissioning of the spray booms in parallel with the reactor cavity draining using conditioned water (cf. reactor cavity and spent fuel pit cooling and treatment system circuit water chemical treatment), then demineralized water;
- Initial mappings before decontamination;
- Lancing hot spots by high pressure water;
- Applying foam to the walls up to human height;
- Rinsing with deionized water under pressure;
- Drying with a squeegee;
- Removal of waste and filters;

- Final mapping after decontamination.

#### *I-2.2.3. Final decontamination after reloading*

The objective of the final decontamination after reloading is the reduction of labile contamination before closing the reactor vessel, and the overall radiological cleanliness of the unit for the next outage.

At the end of decontamination, following values have to be reached:

- Reactor cavity < 100 Bq/cm<sup>2</sup>;
- Internals storage pool:
  - < 200 Bq/cm<sup>2</sup> in the work area;
  - < 400 Bq/cm<sup>2</sup> outside the work area;
  - < 100 Bq/cm<sup>2</sup> in case of "clean" units.

For the realization of the cartographies the average of the points of measurement is recommended for the surface contamination by compartment (tank, internals storage, work area, etc.).

The activities implemented for the final decontamination are as follows:

- Implementation of fine filters (strainers) at the bottom of pools;
- Vacuuming underwater to eliminate hot spots (oxides that come off the fuel when handling assemblies);
- Commissioning of the spray booms in parallel with the reactor cavity draining using conditioned water and demineralized water;
- Initial mappings before decontamination.

#### *I-2.2.4. Decontamination before containment pressure test (10-year outage)*

During 10-year outages, additional decontamination takes place before the containment pressure test and before commissioning of the reactor vessel inspection equipment. This is to avoid the dispersion of pool contamination during the pressure increases in the reactor building. The objectives to be achieved are similar to those of the final decontamination:

- Reactor cavity < 100 Bq/cm<sup>2</sup>;
- Internals storage compartment:
  - < 200 Bq/cm<sup>2</sup> in the work area;
  - < 400 Bq/cm<sup>2</sup> outside the work area;
  - < 100 Bq/cm<sup>2</sup> in case of "clean" units.

This decontamination can be on the critical path of the outage.

#### *I-2.2.5. Additional decontaminations*

- Decontamination of the transfer tube:
  - A decontamination of the transfer tube each second outage is recommended, going from the fuel building side to the side of the reactor building in order

to carry out the activity before the shutdown. Several companies have developed a specific tool for this activity;

— Decontamination of the mast of the unloading machine:

- External decontamination of the mast is performed from the hood and consists of rinsing the mast. Foam is applied and rinsed. The internal decontamination of the mast is recommended for modifications, during decennial outages and according to the EDF maintenance program requirements;

— Decontamination of the hood of the unloading machine:

- Decontamination of the hood of the unloading machine is recommended at each outage for reloading. It consists of rinsing with hot water under pressure.

#### *I-2.2.6. Outlook*

As part of the optimization of the decontaminations, robots equipped with a brushing system for decontaminating the floor and the walls of the reactor cavity are currently being tested.

#### *I-2.2.7. Special case of units affected by hot spots*

The divers intervene either fortuitously or on units with very high dose rates at bottom of the reactor cavity which would prohibit work after draining. Divers often intervene following stellite pump bearing degradations (CVCS pump bearing for example) which generate high dose rate ( $^{60}\text{Co}$ ) in the long term. These operations maintain the state of cleanliness and significant dose savings. The constraints related to decontamination by divers include:

- The duration of the activity longer than the standard decontamination;
- The availability of the polar crane or the fuel unloading machine;
- The temperature of the water has to be below 30°C or even 28°C;
- A hyperbaric chamber is required, near hospital or transportable box;
- Decontamination by divers can take place before unloading, after unloading or after reloading.

### **I-3. GERMAN CASE STUDY – FSD DECONTAMINATION AT GRAFENRHEINFELD NPP**

Permission to reproduce is the courtesy of Framatome, France and Preussen Elektra, Germany - Source Framatome & Nuclear Engineering International – Dec 2017 – Ref. [I-1].

At the end of 2010 the German government decided on a life extension program for the German reactors for an average of 12 years. As a result of this, the operating company Preussen Elektra decided at an early stage that FSD would play a key part in the refurbishment activities at its plants. Framatome was contracted to plan and perform the FSD during the 2010 refuelling outage at Grafenrheinfeld NPP, followed by a specific passivation treatment during the plant restart.

Subsequently the German government made the decision to phase out its nuclear power program by 2022, however this Grafenrheinfeld FSD was done specifically as part of the lifetime extension program as proposed at the time.

The FSD at Grafenrheinfeld involved the simultaneous decontamination of the complete primary circuit and auxiliary systems. Planning for the application was done in close collaboration with Grafenrheinfeld and Framatome which was monitored by an independent consultancy and the German technical inspection association, TÜV.

Framatome’s chemical oxidation reduction decontamination (CORD®) was applied for the FSD at Grafenrheinfeld. CORD comprises multi-cycle, regenerative chemical decontamination processes, as shown in the Figure I-11.

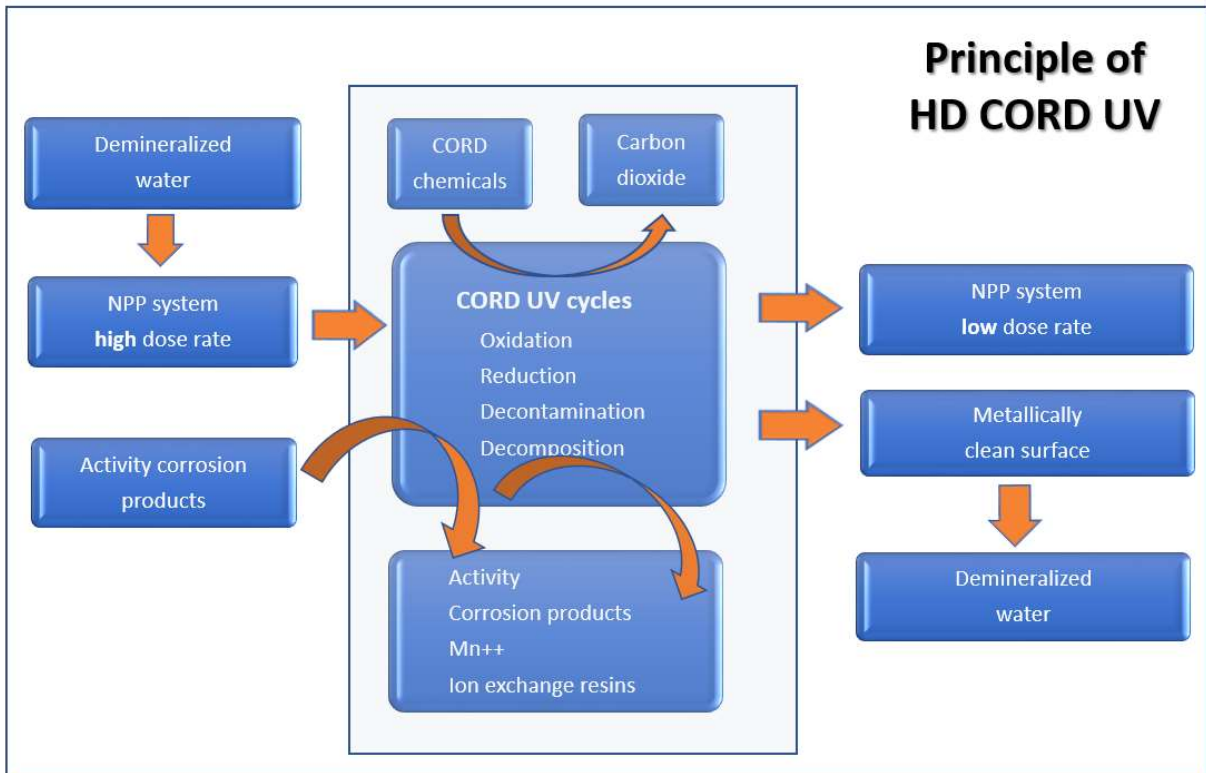

FIG. I-11. CORD® process.

One of the major advantages of CORD is the ability to tailor the process to site requirements and goes hand in hand with low waste generation.

For the FSD the plant’s systems were used together with Framatome’s automated modular decontamination appliance (AMDA®) for chemical process control. That included sampling and injection of chemicals, acceleration of overall project execution by flexible and efficient cleaning via ion exchange resin and mechanical filtration, and ultraviolet (UV) decomposition of the decontamination chemicals to minimise total RAW volume, as shown in the Figure I-12.

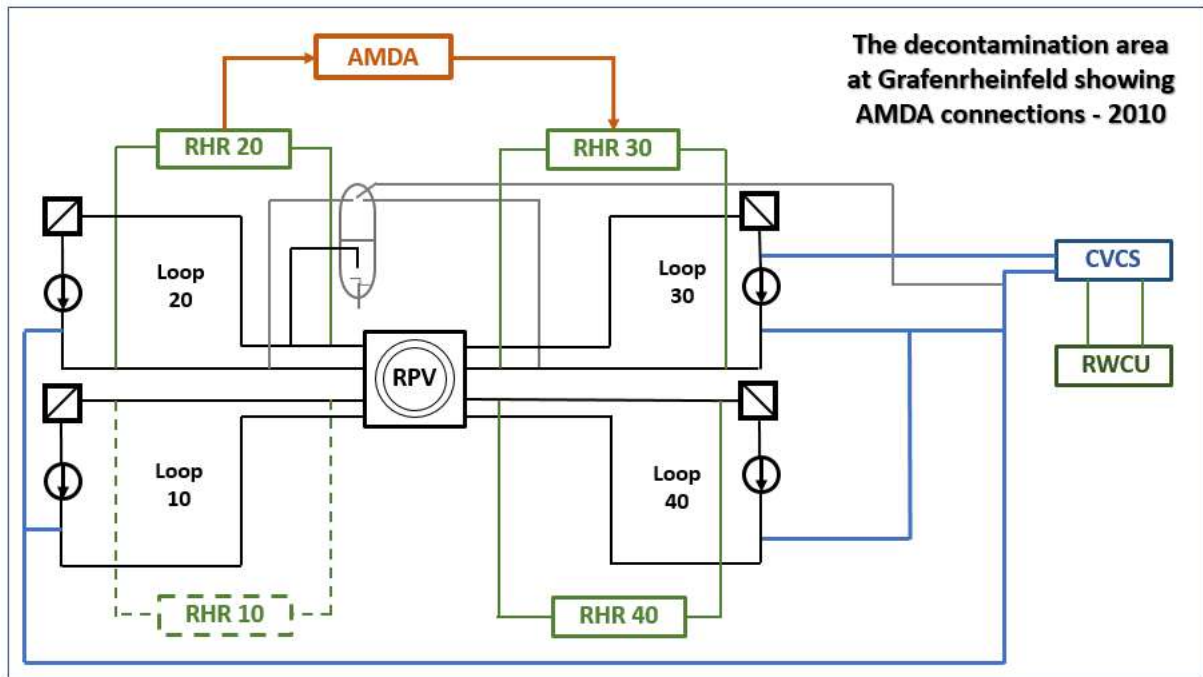

FIG. I-12. AMDA® process.

In 2010 three cycles of the HP CORD UV process were applied with an average DF of 60.5. The results are presented in Table I-5.

TABLE I-5. DOSE RATES BEFORE AND AFTER DECONTAMINATION IN 2010

Location	Number of measuring points	Average dose rates (mSv/h)		Decontamination factor (DF)
		Before	After	
SG tubing area	16	0.102	0.002	67
Pressuriser, spraylines, surgeline	12	3.366	0.097	42
Primary loops	16	5.831	0.070	96
RHR system	9	0.627	0.091	17
Volume control system	14	8.345	0.381	85

Average contact dose rates for the steam generator shell, the main coolant loops, the pressuriser and connected piping were below 0.1mSv/hr. Visual inspections showed clean metallic surfaces. These results were consistent with the Framatome experience gathered at previous FSDs at Stade NPP and Obrigheim NPP using the HP CORD UV process.

In 2015 Preussen Elektra decided to permanently shut down Grafenrheinfeld and perform a final FSD to prepare for the decommissioning activities. The primary focus of this FSD was to reduce dose of the primary system components to prepare for the future decommissioning works. The same HP CORD UV process was used (4 cycles instead of 3, due to the decreased time pressure during this application).

The results related to activity and corrosion products removed are presented in Table I-6.



TABLE I-6. DATA FROM THE DECONTAMINATION IN 2016

FSD Grafenrheinfeld 2016		
Activity and corrosion products removed	Corrosion products (Fe, Cr, Ni)	185.6kg
	Zinc	4.6kg
	Total activity removed (>99% <sup>60</sup> Co)	2.8 x 10 <sup>13</sup> (757Ci)
Waste	Ion exchange resins	7.8m <sup>3</sup>

The results related to dose rates before and after decontamination are presented in Table I-7.

TABLE I-7. DOSE RATES BEFORE AND AFTER DECONTAMINATION IN 2016

Location	Number of measuring points	Average dose rates (mSv/h)		Decontamination factor (DF)
		Before	After	
SG tubing area	16	0.143	0.0008	189
Pressuriser, spraylines, surgeline	12	0.706	0.010	112
Primary loops	16	1.69	0.018	272
RHR system	14	0.303	0.015	24
Volume control system	21	1.184	0.025	98

The ambient dose rate at the component location was reduced by a factor of 14 to only 9μSv/hr. The average dose rate at the measuring points was 11μSv/hr with an average DF of 155. This showed clearly the value of performing an FSD to support the planning and execution of decommissioning activities at Grafenrheinfeld.

#### I-4. US CASE STUDY – MONTICELLO NPP

Permission to reproduce is the courtesy of Barker, D., Xcel Energy, US.

##### I-4.1. Description of problem

The underwater robot utilized at Monticello NPP to decontaminate the reactor cavity may not have been effective due to potentially recontamination of the cavity after using the robot.

##### I-4.2. Evaluation details

During 1R29, an underwater robot was obtained through a vendor to decontaminate the reactor cavity walls while flooded up. Industry operating experience revealed significant results, to the point that methods of decontamination other than mopping/scrubbing were not required after draining down. Monticello attempted to utilize this robot to capture the efficiency savings with not having to apply a strippable coating.

The robot was put into use on or around 5/1/2019, with cavity drain down occurring on 5/4/19. As part of the evolution, a 600gpm Tri-Nuke filter (from Tri Nuclear Corp.) was utilized to collect the discharge of the robot and capture the contamination. The robot was utilized for 24

hours in the reactor cavity. As part of the cavity design, there were certain places where the robot could not clean effectively and was not utilized by the team in those spots. These spots amounted to less than half of the cavity floor. During cleaning, a visual difference was observed in the colour of the cavity walls.

Robotic cleaning was scheduled to occur between core verification and cavity drain down. The outboard main steam isolation valve work occurring was delayed, extending the window between core verification and drain down. Numerous potential CRUD burst causing evolutions occurred after the cleaning, which prompted a review of the results.

### I-4.3. Evaluation results

A comparison of conditions to the 2017 refuelling outage was conducted. The 2017 refuelling outage had numerous CRUD bursts, and dose rate conditions that were similar in nature to the 2019 outage. Conditions in the cavity for initial drain down and post-decon in 2017 were less than desirable (see Table I-8 for contamination levels).

TABLE I-8. CONTAMINATION LEVELS IN 2017

Survey	Max B/G Contamination (dpm/100cm <sup>2</sup> )	Average B/G Contamination (dpm/100cm <sup>2</sup> )	Max alpha Contamination (dpm/100cm <sup>2</sup> )
Cavity Drain Down	200,000,000	92,857,143	88422
RPV Head Installed	8,000,000	2,713,000	464

Dose rates in the cavity ranged from 80-250 mrem/hr on initial drain down and 40-120 mrem/hr after the RPV head was installed.

The 2019 refuelling outage survey data is shown in Table I-9.

TABLE I-9. CONTAMINATION LEVELS IN 2019

Survey	Max B/G Contamination (dpm/100cm <sup>2</sup> )	Average B/G Contamination (dpm/100cm <sup>2</sup> )	Max alpha Contamination (dpm/100cm <sup>2</sup> )
Initial Cavity Survey (pre-flood up)	443,300	217,016	118
Cavity Drain Down	16,000,000	2,317,028	4161
RPV Head Installed	1,000,000	251,309	359

Dose rates in the cavity for the 2019 refueling outage ranged between 60-200 mrem/hr on initial drain down and 40-80 after the RPV head was installed.

The data reflects a significant improvement in contamination levels found post-drain down between outages. Of interesting note, contamination on the walls post-drain down in 2019 averaged 221,827 dpm/100cm<sup>2</sup>. While the survey data is not descriptive enough to determine whether each smear taken was on the walls or the floor, the data seems to reflect that in areas where the robot was able to decontaminate, the method was very effective.

Floor level contaminations reflect higher levels. Comparing to the 2017 outage, contamination levels were less. It is not conclusive whether the survey data taken on the floor of the cavity was in areas where the robot could not reach (i.e. hatches), or whether these areas were potentially re-contaminated from evolutions that cause deposition, such as moving the steam

dryer and moisture separator. The two highest smears on the floor were in an area between the weir wall and the reactor cavity, which is in the travel path of the moisture separator and steam dryer.

Another potential CRUD burst occurred during the backwash and precoat of the fuel pool cooling filter demineralizers. At this time, the fuel pool gates were open, and the reactor cavity was flooded. The CRUD burst created a visual "cloud" in the spent fuel pool. While dose rates increased on the refuel floor in relation to this event, it is unknown whether the CRUD burst affected the robotic cleaning effectiveness.

#### **I-4.4. Lessons learned**

It is recommended that the robot is utilized for future outages based upon the improvement in contamination levels. However, it is also recommended to schedule the cavity cleaning closer to reassembly to minimize the potential effects of CRUD burst causing evolutions on final contamination levels.

### **I-5. FINNISH CASE STUDY – FINNISH REGULATIONS FOR DECONTAMINATION DURING OPERATION**

Permission to reproduce is the courtesy of Lampen, M., Stuk, Finland.

The following are excerpts of STUK regulations Ref.[I-2].

#### **I-5.1. Component decontamination**

“A nuclear facility has to have rooms for the decontamination, repair and maintenance of activated or contaminated components and their parts. It is possible to place all systems and equipment that are of essential importance for decontamination in the decontamination rooms. In addition, separate rooms with radiation shielding have to be provided for the decontamination of highly activated and contaminated components.

If necessary, it is possible to handle the components and objects to be decontaminated remotely and in a protected manner.

Components requiring decontamination have to be identified during plant design. Their transport has to be planned such that their disassembling and transfer for decontamination does not result in significant occupational doses.”[I-2]

#### **I-5.2. Accumulation of radioactive substances and systems decontamination**

“Components and their parts have to be designed to prevent unintentional accumulation of radioactive substances. The materials and treatment of the surfaces of systems and components have to reduce contamination. The uncontrolled accumulation of particles containing radioactive substances in pipelines has to be prevented by fluid flow and chemistry design. The accumulation of radioactive substances in individual components and systems has to be anticipated by making the accumulation points shieldable and, if necessary, flushable.

A nuclear power plant’s reactor circuit as well as primary circuit components containing significant amounts of radioactive substances has to be decontaminable.

It is possible to connect the necessary flushing and decontamination equipment to systems and piping that may contain radioactive liquids.

Pipelines have to be designed with few vent and drain lines. Drainage has to be led to a floor trap or a closed system. Venting has to be led to a radioactive gas treatment system.”[I-2]

### **I-5.3. Water chemistry of the primary and secondary circuit - decontamination**

“The facility has to have procedures in place for routine decontamination of individual components and component parts. The effectiveness of the decontamination process has to be monitored, and records have to be kept of the decontamination results.

The chemical decontamination method applied to the large-scale purification of the interior surfaces of the primary circuit has to be effective without causing excessive corrosion to the materials. The purification process has to be monitored with chemical and radiochemical practices. Passivation has to be performed on the decontaminated interior surfaces of the primary circuit before the reactor is made critical. In the outage following decontamination, special attention has to be paid to component parts and the condition of the components and seals.”[I-2]

### **I-5.4. Documentation to be submitted to STUK for decontamination**

“When the primary circuit and systems connected to the primary circuit are decontaminated, a decontamination plan has to be submitted to STUK for approval. The decontamination plan has to describe at least the following:

- The decontamination process used
- Suitability assessment of the decontamination method for the material to be decontaminated
- Target level of decontamination
- Radiation safety plan during decontamination
- Treatment plan for RAW generated during decontamination
- Decontamination follow-up programme.”[I-2]



---

## REFERENCES

- [I-1] FISCHER, M. et al., Double decontamination, NEI magazine (2017) 5.
- [I-2] STUK, GUIDE YVL B.5 - REACTOR COOLANT CIRCUIT OF A NUCLEAR POWER PLANT, YVL Guide, Finland YVL B.5, 02.09.2019., Stuk, Helsinki (2019) 20 pp.



## GLOSSARY

The following definitions have been partly taken from the IAEA Safety Glossary, Terminology Used in Nuclear Safety and Radiation Protection, 2018 Edition, IAEA, Vienna (2019) [16].

**automated modular decontamination appliance.** A Framatome proprietary equipment for chemical process control during an FSD including sampling and injection of chemicals, ion exchange resin purification and mechanical filtration, and ultraviolet (UV) decomposition of the decontamination chemicals to minimize total radioactive waste volume.

**background.** The dose or dose rate (or an observed measure related to the dose or dose rate) attributable to all sources other than the one(s) specified.

**barrier.** A physical obstruction that prevents or inhibits the movement of people, radionuclides or some other phenomenon (e.g. fire), or provides shielding against radiation.

**characterization.** Determination of the nature and activity of radionuclides present in a specified place.

**best practicable environmental option.** The outcome of a systematic consultative and decision-making procedure which emphasizes the protection and conservation of the environment across land, air and water.

**citrox.** A dilute regenerative process for both PWR and BWR reactor piping and system components. The CITROX process comprises citric acid and oxalic acid. It was developed in the 1980s.

**containment.** Methods or physical structures designed to prevent or control the release and the dispersion of radioactive substances.

**contamination.** Radioactive substances on surfaces, or within solids, liquids or gases (including the human body), where their presence is unintended or undesirable, or the process giving rise to their presence in such places.

**contractor.** One that contracts or is party to a contract, such as one that contracts to perform work or provide supplies.

**chemical oxidation reduction decontamination.** A proprietary Framatome decontamination process used for component, sub-system and full system decontamination.

**corrosion.** Progressive surface dissolution of a material. A term generally used for metals. Corrosion can be uniform over the surface of the material or non-uniform through enhanced corrosion in stressed areas at physical discontinuities. The definition has been taken from Ref. [33].

**cost–benefit analysis.** A systematic technical and economic evaluation of the positive effects (benefits) and negative effects (dis-benefits, including monetary costs) of undertaking an action.

**decommissioning.** Administrative and technical actions taken to allow the removal of some or all of the regulatory controls from a facility.

**decontamination.** The complete or partial removal of contamination by a deliberate physical, chemical or biological process. For the purposes of this publication, only surface decontamination is considered.

**decontamination, chemical.** The removal or reduction of radioactive contamination from surfaces by chemical processes. The definition has been taken from Ref. [33].

**decontamination factor.** The ratio of the activity per unit area (or per unit mass or volume) before a particular decontamination technique is applied to the activity per unit area (or per unit mass or volume) after application of the technique.



**design.** The process and the result of developing a concept, detailed plans, supporting calculations and specifications for a facility and its parts.

**discharge.** Planned and controlled release of (usually gaseous or liquid) radioactive substances to the environment.

**dismantling.** The taking apart, disassembling and tearing down of the structures, systems and components of a facility for the purposes of decommissioning

**disposal.** Emplacement of waste in an appropriate facility without the intention of retrieval.

**disposition.** Consigning of, or arrangements for the consigning of, radioactive waste for some specified (interim or final) destination, for example for the purpose of processing, disposal or storage.

**foreign material.** Any material not part of any system or component as designed. This includes unexpected dirt and debris, tools, equipment combustible materials, machine tailings, grinding particles, paint chips, leak sealing compounds, unapproved chemicals, or any other item or residue which, left inside the system, could adversely affect its operation, components or chemistry. The definition has been taken from Ref. [34].

**full system decontamination.** Refers to decontamination of all major plant systems simultaneously. The reactor pressure vessel may be included or bypassed, and the reactor may be fueled ('fuel-in') or defueled ('fuel-out'). Reactor coolant pumps are usually run to provide adequate flow.

**hot spot.** Areas of radioactive contamination higher than average.

**occupational exposure.** Exposure of workers incurred during their work.

**operating organization (operator).** Any person or organization applying for authorization or authorized to operate an authorized facility and responsible for its safety.

**operation.** All activities performed to achieve the purpose for which an authorized facility was constructed. For a nuclear power plant, this includes maintenance, refuelling, in-service inspection and other associated activities.

**process.** A course of action or proceeding, especially a series of progressive stages in the manufacture of a product or some other operation.

**quality management.** The function of a management system that provides confidence that specified requirements will be fulfilled.

**reactor coolant system.** Main coolant recirculation system. This term is usually applied to PWRs.

**regulatory body.** An authority or a system of authorities designated by the government of a state as having legal authority for conducting the regulatory process, including issuing authorizations, and thereby regulating the safety of nuclear installations, radiation safety, the safety of radioactive waste management and safety in the transport of radioactive material.

**safety assessment.** Assessment of all aspects of facilities and activities that are relevant to protection and safety; for an authorized facility, this includes siting, design and operation of the facility. This will normally include risk.

**storage.** The holding of radioactive sources, radioactive material, spent fuel or radioactive waste in a facility that provides for their/its containment, with the intention of retrieval.

**structures, systems and components.** A general term encompassing all of the elements (items) of a facility or activity that contribute to protection and safety, except human factors.

**vendor.** A person or company that sells goods or services.

**waste.** Material for which no further use is foreseen.

**waste acceptance criteria.** Quantitative or qualitative criteria specified by the regulatory body or specified by an operator and approved by the regulatory body, for the waste form and waste package to be accepted by the operator of a waste management facility.

**waste management, radioactive.** All administrative and operational activities involved in the handling, pre-treatment, treatment, conditioning, transport, storage and disposal of radioactive waste.

**waste, secondary.** Radioactive waste resulting as a by-product from the processing of primary radioactive waste.



## LIST OF ABBREVIATIONS

A	ampere
AGR	advanced gas-cooled reactor
ALARA	as low as reasonably achievable
AMDA	automated modular decontamination appliance
BPEO	best practicable environmental option
BWR	boiling water reactor
CANDU	Canada deuterium uranium
CORD	chemical oxidation reduction decontamination.
CVCS	chemical and volume control system
DF	decontamination factor
DR	dose rate
EDF	Electricité de France
EPRI	Electric Power Research Institute
FBR	fast breeder reactor
FSD	fuel system decontamination
HVAC	heating, ventilating, and air conditioning
IAEA	International Atomic Energy Agency
ICRP	International Commission on Radiological Protection
IGALL	international generic ageing lessons learned
ILW	intermediate level waste
INPO	Institute of Nuclear Power Operators
ISO	International Organization for Standardization
ISOE	information system on occupational exposure
IX	ion exchange
LLW	low level (radioactive) waste
MAA	multi-attribute analysis
MS	member states
NEA	Nuclear Energy Agency
NEI	Nuclear Energy Institute
NPP	nuclear power plant
O&M	operation and maintenance
pH	potential for hydrogen
PHWR	pressurized heavy water reactor
PM	project management
PPE	personal protective equipment
PVC	polyvinyl chloride
PWR	pressurized water reactor
QM	quality management

R&D	research and development
RAW	radioactive waste
RB	reactor building
RBMK	graphite-moderated nuclear power reactor
RCP	reactor coolant pump
RCS	reactor coolant system
RHRS	residual heat removal system
RP	radiation protection
SG	steam generator
SS	stainless steel
SSC	systems, structures and components
TSO	technical support organization
UFC	ultrasonic fuel cleaning
UKAEA	United Kingdom Atomic Energy Authority
UN	United Nations
VLLW	very low-level waste
WANO	World Association of Nuclear Operators
WWER	water-water energetic reactor

## CONTRIBUTORS TO DRAFTING AND REVIEW

Afzal, A.	Pakistan Atomic Energy Commission, Pakistan
Avagyan, N.	Armenian NPP CJSC, Armenia
Barker, D.	Xcelenergy, USA
Bradley, E.	International Atomic Energy Agency, Austria
Caris, N.	Framatome, South Africa
Delabre, H.	International Atomic Energy Agency, Austria
Duncan, R.	Westinghouse, USA
Deng, J.	State Nuclear Power Plant Services Company, China
Geniaux, A.	Autorité de Sûreté Nucléaire, France
Gilber, L	Brazilian Navy, Brazil
Gordon, I.	International Atomic Energy Agency, Austria
Hagg, J.	Vattenfall, Sweden
Holubek, E.	Wood Nuclear Slovakia, Slovakia
Ibrahim Issa, G.	Nuclear Power Plants Authority, Egypt
Kopecky, P.	CEZ, Czech Republic
Lampen, M.	STUK, Finland
Laraia, M.	Consultant, Italy
Maekelae, K.	International Atomic Energy Agency, Austria
Meyer, W.	International Atomic Energy Agency, Austria
Mykolaichuk, O.	International Atomic Energy Agency, Austria
Rajagopalan, H.	Nuclear Power Corporation of India Ltd., India
Rocher, A.	Electricite de France, France
Sharma, R.	International Atomic Energy Agency, Austria
Stone, C.	South Texas Project, USA
Taghizadeh, N.	Nuclear Power Production and Development Company, Iran
Teixera Marcos, L.	Eletrobas Eletronuclear, Brazil
Vincze, P.	International Atomic Energy Agency, Austria
Yordanova, O.	Kozloduy NPP PLC, Bulgaria

## CONSULTANTS MEETINGS

Vienna, Austria: 5-8 June 2018, 22-25 January 2019, 14-17 October 2019

## TECHNICAL MEETING

Vienna, Austria: 14-16 October 2019



**IAEA**

International Atomic Energy Agency

No. 26

## ORDERING LOCALLY

IAEA priced publications may be purchased from the sources listed below or from major local booksellers.

Orders for unpriced publications should be made directly to the IAEA. The contact details are given at the end of this list.

### NORTH AMERICA

***Bernan / Rowman & Littlefield***

15250 NBN Way, Blue Ridge Summit, PA 17214, USA

Telephone: +1 800 462 6420 • Fax: +1 800 338 4550

Email: [orders@rowman.com](mailto:orders@rowman.com) • Web site: [www.rowman.com/bernan](http://www.rowman.com/bernan)

### REST OF WORLD

Please contact your preferred local supplier, or our lead distributor:

***Eurospan Group***

Gray's Inn House  
127 Clerkenwell Road  
London EC1R 5DB  
United Kingdom

***Trade orders and enquiries:***

Telephone: +44 (0)176 760 4972 • Fax: +44 (0)176 760 1640

Email: [eurospan@turpin-distribution.com](mailto:eurospan@turpin-distribution.com)

***Individual orders:***

[www.eurospanbookstore.com/iaea](http://www.eurospanbookstore.com/iaea)

***For further information:***

Telephone: +44 (0)207 240 0856 • Fax: +44 (0)207 379 0609

Email: [info@eurospangroup.com](mailto:info@eurospangroup.com) • Web site: [www.eurospangroup.com](http://www.eurospangroup.com)

### Orders for both priced and unpriced publications may be addressed directly to:

Marketing and Sales Unit

International Atomic Energy Agency

Vienna International Centre, PO Box 100, 1400 Vienna, Austria

Telephone: +43 1 2600 22529 or 22530 • Fax: +43 1 26007 22529

Email: [sales.publications@iaea.org](mailto:sales.publications@iaea.org) • Web site: [www.iaea.org/publications](http://www.iaea.org/publications)

**International Atomic Energy Agency  
Vienna**