



Si photodiodes

Contents

1. Operating principle

- p.02 1-1 Structure
- 1-2 Equivalent circuit

2. Characteristics

- p.03 2-1 Current vs. voltage characteristics
- 2-2 Linearity
- 2-3 Spectral response
- 2-4 Noise characteristics
- 2-5 Sensitivity uniformity
- 2-6 Response speed

3. How to use

- p.09 3-1 Connection to an op amp
- 3-2 Application circuit examples

4. Applications

- p.16 4-1 Particle size analyzers (laser diffraction and scattering method)
- 4-2 Barcode readers
- 4-3 UV sensors
- 4-4 Rotary encoders
- 4-5 Color sensors
- 4-6 VICS (Vehicle Information and Communication System)

Photodiodes are photosensors that generate a current or voltage when the PN junction in the semiconductor is irradiated by light. The term photodiode can be broadly defined to include even solar batteries, but it usually means sensors that accurately detect changes in light level. Si photodiodes provide the following features and are widely used to detect the presence or absence, intensity, and color of light, etc.

- ❑ Excellent linearity with respect to incident light
- ❑ Mechanically rugged
- ❑ Low noise
- ❑ Compact and lightweight
- ❑ Wide spectral response range
- ❑ Long life

The lineup of Si photodiodes we manufacture utilizing our own advanced semiconductor process technologies covers a broad spectral range from the near infrared to ultraviolet and even to high-energy regions, and features high-speed response, high sensitivity, and low noise. Hamamatsu Si photodiodes are used in a wide range of applications including medical and analytical fields, scientific measurements, optical communications, and general electronic products. These photodiodes are available in various packages such as metal, ceramic, and plastic packages, as well as in surface mount types. Hamamatsu also offers custom-designed devices to meet special needs.

❖ Hamamatsu Si photodiodes

Type	Features	Product examples
Si photodiode	These photodiodes feature high sensitivity and low noise, and they are specifically designed for precision photometry and general photometry in the visible range.	<ul style="list-style-type: none"> ● For UV to near infrared range ● For visible to near infrared range ● For visible range ● RGB color sensor ● For vacuum ultraviolet (VUV) detection ● For monochromatic light detection ● For electron beam detection
Si PIN photodiode	Si PIN photodiodes deliver high-speed response when operated with a reverse voltage applied and are suitable for use in optical fiber communications, optical disk pickups, etc.	<ul style="list-style-type: none"> ● Cutoff frequency: 10 MHz or more
IR-enhanced Si PIN photodiode	These photodiodes have improved sensitivity in the near infrared region above 900 nm.	<ul style="list-style-type: none"> ● For YAG laser monitoring
Multi-element Si photodiode	Si photodiode arrays consist of multiple elements formed in a linear or two-dimensional arrangement in a single package. These photodiode arrays are used in a wide range of applications such as light position detection and spectrophotometry.	<ul style="list-style-type: none"> ● Segmented photodiode ● One-dimensional photodiode array
Si photodiode with preamp, thermoelectrically cooled Si photodiode	Si photodiodes with preamp incorporate a photodiode and a preamplifier into the same package, so they are highly immune to external noise and allow compact circuit design. Thermoelectrically cooled types offer drastically improved S/N.	<ul style="list-style-type: none"> ● For analysis and measurement

1. Operating principle

1 - 1 Structure

Figure 1-1 shows a cross section example of a Si photodiode. The P-type region (P-layer) at the photosensitive surface and the N-type region (N-layer) at the substrate form a PN junction which operates as a photoelectric converter. The usual P-layer for a Si photodiode is formed by selective diffusion of boron to a thickness of approx. 1 μm or less, and the intrinsic region at the junction between the P-layer and N-layer is known as the depletion layer. By controlling the thickness of the outer P-layer, N-layer, and bottom N⁺-layer as well as the dopant concentration, the spectral response and frequency response described later can be controlled.

When a Si photodiode is illuminated by light and if the light energy is greater than the band gap energy, the valence band electrons are excited to the conduction band, leaving holes in their place in the valence band [Figure 1-2]. These electron-hole pairs occur throughout the P-layer, depletion layer and N-layer materials. In the depletion layer the electric field accelerates these electrons toward the N-layer and the holes toward the P-layer. Of the electron-hole pairs generated in the N-layer, the electrons, along with electrons that have arrived from the P-layer, are left in the N-layer conduction band. The holes are diffused through the N-layer up to the depletion layer, accelerated, and collected in the P-layer valence band. In this manner, electron-hole pairs which are generated in proportion to the amount of incident light are collected in the N-layer and P-layer. This results in a positive charge in the P-layer and a negative charge in the N-layer. When an electrode is formed from each of the P-layer and N-layer and is connected to an external circuit, electrons will flow away from the N-layer, and holes will flow away from the P-layer toward the opposite respective electrodes, generating a current. These electrons and holes generating a current flow in a semiconductor are called the carriers.

[Figure 1-1] Schematic of Si photodiode cross section

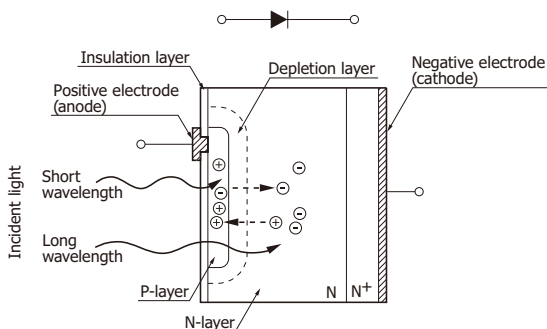

KPDC0002EA

[Figure 1-2] Si photodiode PN junction state

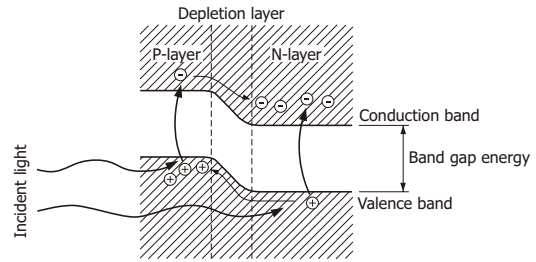

KPDC0003EA

1 - 2 Equivalent circuit

An equivalent circuit of a Si photodiode is shown in Figure 1-3.

[Figure 1-3] Si photodiode equivalent circuit

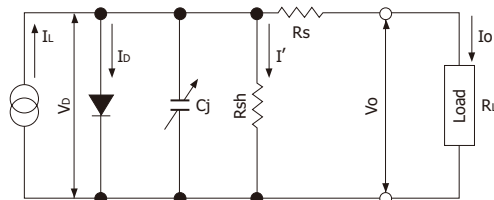

- I_L : current generated by incident light (proportional to light level)
- V_o : voltage across diode
- I_o : diode current
- C_j : junction capacitance
- R_{sh} : shunt resistance
- I' : shunt resistance current
- R_s : series resistance
- V_o : output voltage
- I_o : output current

KPDC0004EA

Using the above equivalent circuit, the output current (I_o) is given by equation (1-1).

$$I_o = I_L - I_D - I' = I_L - I_s \left(\exp \frac{q V_D}{k T} - 1 \right) - I' \dots \dots \dots (1-1)$$

- I_s : photodiode reverse saturation current
- q : electron charge
- k : Boltzmann's constant
- T : absolute temperature of photodiode

The open circuit voltage (V_{oc}) is the output voltage when $I_o=0$, and is expressed by equation (1-2).

$$V_{oc} = \frac{k T}{q} \ln \left(\frac{I_L - I'}{I_s} + 1 \right) \dots \dots \dots (1-2)$$

If I' is negligible, since I_s increases exponentially with respect to ambient temperature, V_{oc} is inversely proportional to the ambient temperature and proportional to the log of I_L . However, this relationship does not hold when detecting low-level light.

The short circuit current (I_{sc}) is the output current when load resistance (R_L)=0 and $V_o=0$, and is expressed by equation (1-3).

$$I_{sc} = I_L - I_s \left(\exp \frac{q \times I_{sc} \times R_s}{k T} - 1 \right) - \frac{I_{sc} \times R_s}{R_{sh}} \dots \dots \dots (1-3)$$

In equation (1-3), the 2nd and 3rd terms become the cause that determines the linearity limit of the short circuit current. However, since R_s is several ohms and R_{sh} is 10^7 to 10^{11} ohms, these terms become negligible over quite a wide range.

2. Characteristics

2-1 Current vs. voltage characteristics

When a voltage is applied to a Si photodiode in a dark state, the current versus voltage characteristics observed are similar to the curve of a rectifier diode as shown by ① in Figure 2-1. However, when light strikes the photodiode, the curve at ① shifts to ② and increasing the incident light level shifts this characteristic curve still further to position ③ in parallel. As for the characteristics of ② and ③, if the Si photodiode terminals are shorted, a short circuit current I_{sc} or I_{sc}' proportional to the light level will flow from the anode to the cathode. If the circuit is open, an open circuit voltage V_{oc} or V_{oc}' will be generated with the positive polarity at the anode.

V_{oc} changes logarithmically with changes in the light level but greatly varies with temperature, making it unsuitable for measurement of light level. Figure 2-2 shows a typical relation between I_{sc} and incident light level and also between V_{oc} and incident light level.

[Figure 2-1] Current vs. voltage characteristics

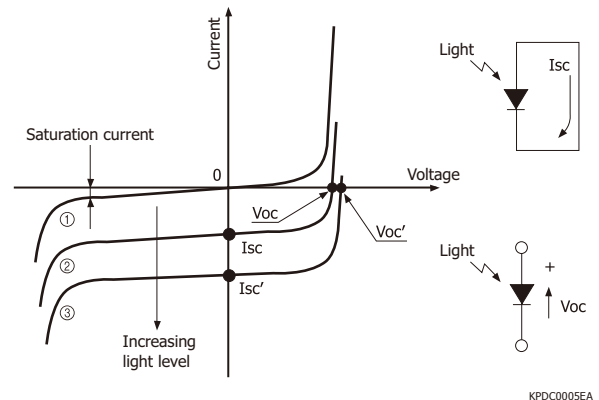

[Figure 2-2] Output signal vs. incident light level (S2386-5K)

(a) Short circuit current

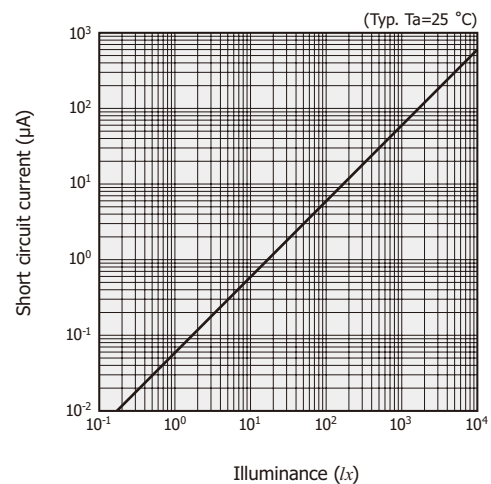

(b) Open circuit voltage

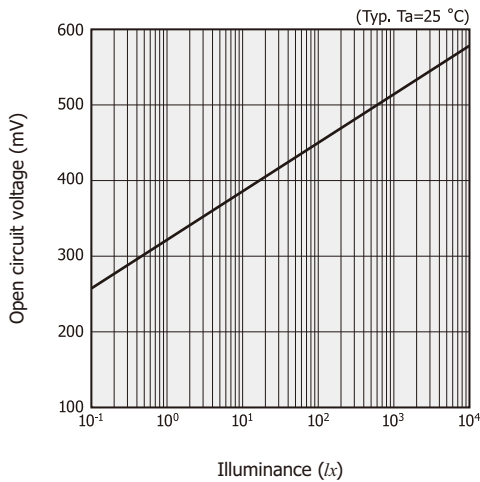

KPDB0002EB

Figure 2-3 shows the basic circuit for measuring a photocurrent. In the circuit shown at (a), the voltage ($I_o \times R_L$) is amplified by an amplifier with gain G . A higher linearity is maintained by applying a reverse voltage to the photodiode [Figure 2-6 (a), Figure 2-7]. The circuit shown at (b) uses an op amp to connect to the photodiode. If we let the open-loop gain of the op amp be A , the negative feedback circuit allows the equivalent input resistance (equivalent to load resistance R_L) to be R_f/A which is several orders of magnitude smaller than R_L . Thus this circuit enables ideal measurements of short circuit current. When necessary to measure the photocurrent over a wide range, the proper values of R_L and R_f must be selected to prevent output saturation even when the incident light level is high.

[Figure 2-3] Connection examples

(a) When load resistor is connected

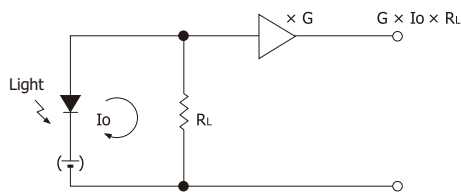

(b) When op amp is connected

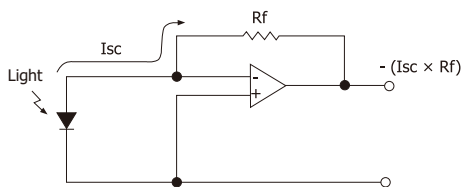

KPDC0006EA

Figure 2-4 is a magnified view of the zero region of curve ① shown in Figure 2-1. This proves that the change in dark current (I_D) is approximately linear in a voltage range of about ± 10 mV. The slope in this straight line indicates the shunt resistance (R_{sh}), and

this resistance is the cause of thermal noise current described later. For Hamamatsu Si photodiodes, the shunt resistance values are obtained using a dark current measured with 10 mV applied to the cathode.

[Figure 2-4] Dark current vs. voltage (enlarged view of zero region of curve ① in Figure 2-1)

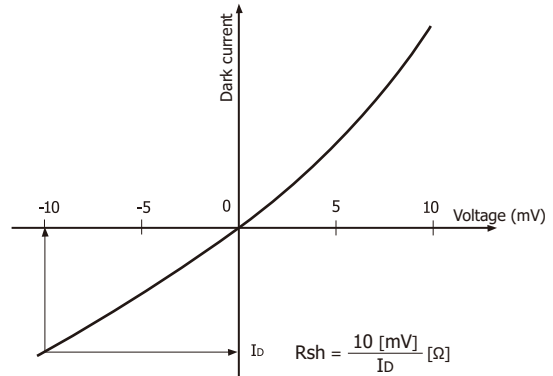

KPDB0004EA

2-2 Linearity

The photocurrent of the Si photodiode is extremely linear with respect to the incident light level. When the incident light is within the range of 10^{-12} to 10^{-2} W, the achievable range of linearity is higher than nine orders of magnitude (depending on the type of photodiode and its operating circuit, etc.). The lower limit of this linearity is determined by the noise equivalent power (NEP), while the upper limit depends on the load resistance, reverse voltage, etc., and is given by equation (2-1). As the series resistance component increases, the linearity degrades.

$$P_{sat} = \frac{V_{bi} + V_R}{(R_S + R_L) \times S_\lambda} \dots \dots \dots (2-1)$$

- P_{sat} : input energy [W] at upper limit of linearity ($P_{sat} \leq 10$ mW)
- V_{bi} : contact voltage [V] (approx. 0.2 to 0.3 V)
- V_R : reverse voltage [V]
- R_S : photodiode series resistance (several ohms)
- R_L : load resistance [Ω]
- S_λ : photosensitivity [A/W] at wavelength λ

[Figure 2-5] Current vs. voltage characteristics and load lines

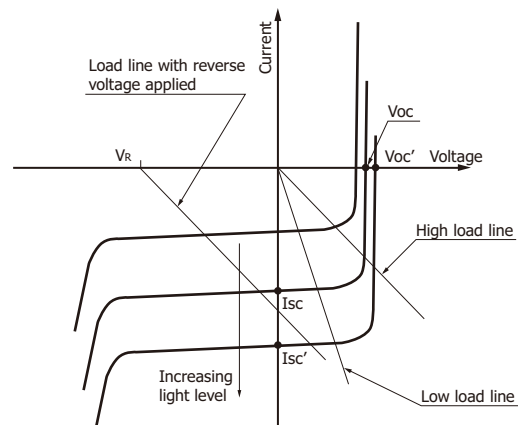

KPDB0003ED

In some cases, applying a reverse voltage is effective in enhancing the upper limit of linearity. Figure 2-6 shows connection examples for applying a reverse voltage. (a) is an example in which the photocurrent is converted into voltage with load resistance and amplified with an amplifier. When the load resistance is large, the upper limit of linearity is limited [equation (2-1)]. This prevents the connection of large load resistance, and is not suitable for low-light-level detection. (b) is an example in which a photodiode is connected directly to the op amp input terminal and current-to-voltage conversion is performed using feedback resistance (R_f). In this case, the load resistance for the photodiode is the input resistance to the op amp and is a constant value. Since the input resistance of the op amp is low (several ohms), as long as the op amp output does not saturate, the photocurrent also does not saturate regardless of how large the feedback resistance is set to. Therefore, (b) is suitable for low-light-level detection. Figure 2-7 shows how the upper limit of linearity changes with a reverse voltage (V_R). While application of a reverse voltage to a photodiode is useful in improving the linearity, it also increases dark current and noise levels. Since an excessive reverse voltage may damage the photodiode, use a reverse voltage that will not exceed the absolute maximum rating, and make sure that the cathode is maintained at a positive potential with respect to the anode.

When laser light is condensed on a small spot, caution is required because the amount of light per unit area increases, and linearity deteriorates.

[Figure 2-6] Connection examples (with reverse voltage applied)

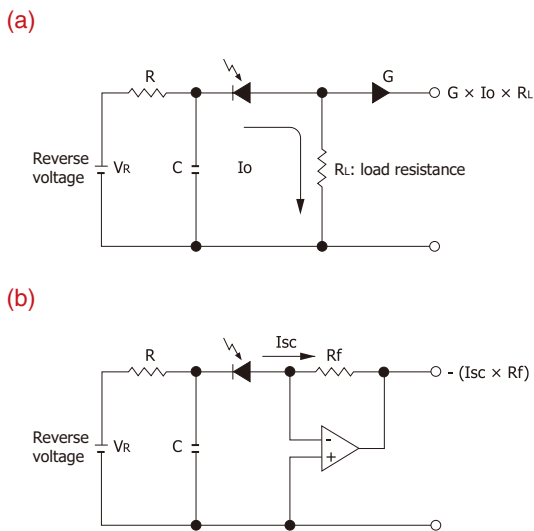

KPDC0008EC

[Figure 2-7] Photocurrent vs. illuminance (S1223)

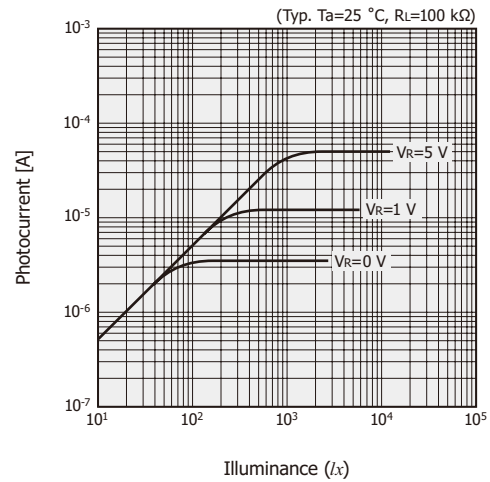

KPDB0009EC

2 - 3 Spectral response

As explained in section 1-1, "Principle of operation," when the energy of absorbed light is lower than the band gap energy of Si photodiodes, the photovoltaic effect does not occur.

The cutoff wavelength (λ_c) can be expressed by equation (2-2).

$$\lambda_c = \frac{1240}{E_g} [\text{nm}] \dots\dots\dots (2-2)$$

E_g : band gap energy [eV]

In the case of Si at room temperature, the band gap energy is 1.12 eV, so the cutoff wavelength is 1100 nm. For short wavelengths, however, the degree of light absorption within the surface diffusion layer becomes very large [Figure 1-1]. Therefore, the thinner the diffusion layer is and the closer the PN junction is to the surface, the higher the sensitivity will be. For normal Si photodiodes, the cutoff wavelength on the short wavelength side is 320 nm, whereas it is 190 nm for UV-enhanced Si photodiodes (S1226/S1336 series, etc.).

The cutoff wavelength is determined by the intrinsic material properties of the Si photodiode and the spectral transmittance of the light input window material. For borosilicate glass and plastic resin coating, wavelengths below approx. 300 nm are absorbed. If these materials are used as the window, the short-wavelength sensitivity will be lost.

When detecting wavelengths shorter than 300 nm, Si photodiodes with quartz windows are used. Measurements limited to the visible light region use a visual-sensitive compensation filter that allows only visible light to pass through it.

Figure 2-8 shows spectral responses for various types of Si photodiodes. The BQ type uses a quartz window

and the BR type a resin-coated window. The S9219 is a Si photodiode with a visual-sensitive compensation filter.

[Figure 2-8] Spectral response (Si photodiodes)

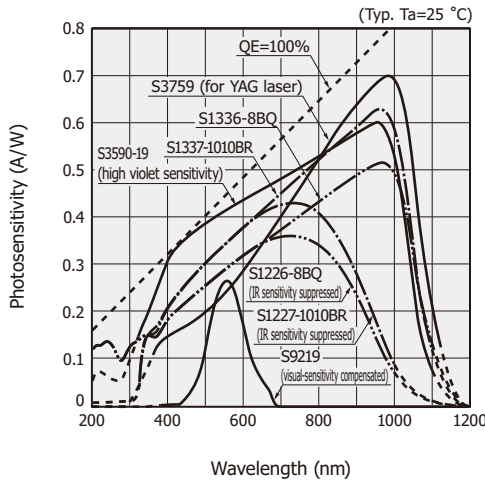

KSPDB0247EB

At a given wavelength, the number of electrons or holes that can be extracted as a photocurrent divided by the number of incident photons is called the quantum efficiency (QE). The quantum efficiency is given by equation (2-3).

$$QE = \frac{S \times 1240}{\lambda} \times 100 [\%] \dots\dots\dots (2-3)$$

S: photosensitivity [A/W]
λ: wavelength (nm)

The IR-enhanced Si PIN photodiode features drastically improved sensitivity in the near infrared region for wavelengths from 900 nm to 1100 nm.

Since silicon has a large light absorption coefficient in the visible and ultraviolet regions, even a photodiode from a thin wafer can sufficiently detect light in these regions. However, in the near infrared region, the light absorption coefficient becomes extremely low (allowing more light to pass through), which lowers the sensitivity. To achieve high sensitivity with silicon in the near infrared region, the light absorption layer could be made thicker by using a thicker silicon wafer, but this causes shortcomings such as the need for high supply voltage, increased dark current, and decreased response speed.

2 - 4 Noise characteristics

Like other types of photosensors, the lower limits of light detection for Si photodiodes are determined by their noise characteristics. The Si photodiode noise current (i_n) is the sum of the thermal noise current or Johnson noise current (i_j) of a resistor which approximates the shunt resistance (Rsh) and the shot

noise currents (i_{SD} and i_{SL}) resulting from the dark current and the photocurrent.

$$i_n = \sqrt{i_j^2 + i_{SD}^2 + i_{SL}^2} [A] \dots\dots\dots (2-4)$$

i_j is viewed as the thermal noise of Rsh and is given by equation (2-5).

$$i_j = \sqrt{\frac{4k T B}{Rsh}} [A] \dots\dots\dots (2-5)$$

k: Boltzmann's constant
T: absolute temperature of photodiode
B: noise bandwidth

When a reverse voltage is applied as in Figure 2-6, there is always a dark current. The shot noise i_{SD} of the dark current is given by equation (2-6).

$$i_{SD} = \sqrt{2q I_D B} [A] \dots\dots\dots (2-6)$$

q : electron charge
 I_D : dark current

The shot noise i_{SL} generated by photocurrent (I_L) due to the incident light is expressed by equation (2-7).

$$i_{SL} = \sqrt{2q I_L B} [A] \dots\dots\dots (2-7)$$

If $I_L \gg 0.026/Rsh$ or $I_L \gg I_D$, the shot noise current i_{SL} of equation (2-7) becomes predominant instead of the noise factor of equation (2-5) or (2-6).

The amplitudes of these noise sources are each proportional to the square root of the noise bandwidth (B) so that they are expressed in units of $A/Hz^{1/2}$ normalized by B.

The lower limit of light detection for Si photodiodes is usually expressed as the incident light level required to generate a current equal to the noise current as expressed in equation (2-5) or (2-6), which is termed the noise equivalent power (NEP).

$$NEP = \frac{i_n}{S} [W/Hz^{1/2}] \dots\dots\dots (2-8)$$

i_n : noise current [$A/Hz^{1/2}$]
S : photosensitivity [A/W]

In cases where i_j is predominant, the relation between NEP and shunt resistance is plotted as shown in Figure 2-9. This relation agrees with the theoretical data.

[Figure 2-9] NEP vs. shunt resistance (S1226-5BK)

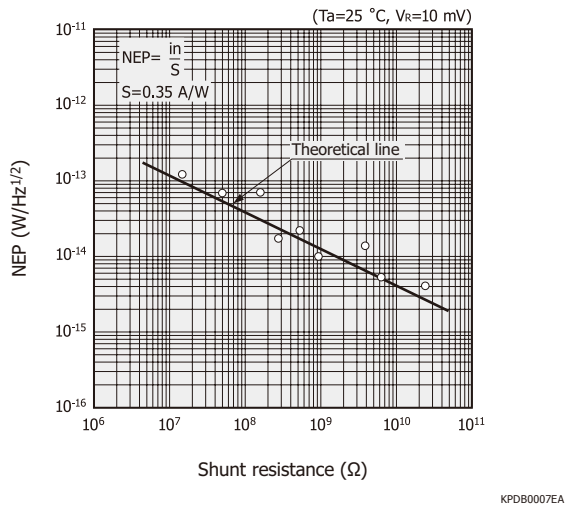

2 - 5 Sensitivity uniformity

This is a measure of the sensitivity uniformity in the photosensitive area. Si photodiodes offer excellent sensitivity uniformity; their nonuniformity in 80% of the effective photosensitive area in the visible to near infrared region is less than 2%. This is measured with a light beam (e.g., from a laser diode) condensed to a small spot from a few microns to dozens of microns in diameter.

[Figure 2-10] Sensitivity uniformity (S1227-1010BQ)

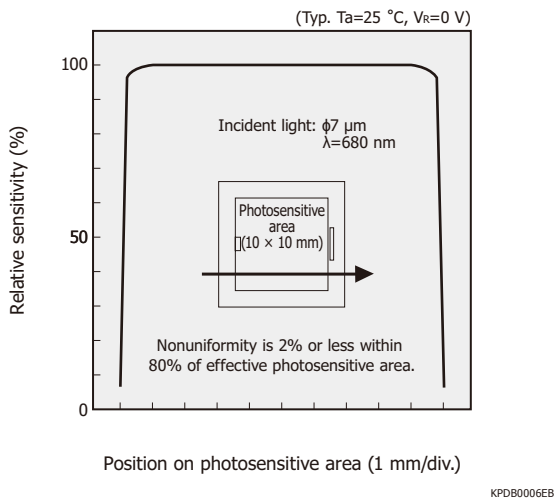

2 - 6 Response speed

The response speed of a photodiode is a measure of how fast the generated carriers are extracted to an external circuit as output current, and it is generally expressed as the rise time or cutoff frequency. The rise time is the time required for the output signal to change from 10% to 90% of the peak output value and is determined by the following factors.

(1) Time constant t_1 of terminal capacitance C_t and load resistance R_L

C_t is the sum of the package capacitance and the photodiode junction capacitance (C_j). t_1 is then given by equation (2-9).

$$t_1 = 2.2 \times C_t \times R_L \dots\dots\dots (2-9)$$

To shorten t_1 , the design must be such that C_t or R_L is made smaller. C_j is nearly proportional to the photosensitive area (A) and inversely proportional to the depletion layer width (d). Since the depletion layer width is proportional to the second to third root of the product of the reverse voltage (V_R) and the electrical resistivity (ρ) of the substrate material, this is expressed by equation (2-10).

$$C_j \propto A \{(V_R + 0.5) \times \rho\}^{-1/2 \text{ to } -1/3} \dots\dots\dots (2-10)$$

Accordingly, to shorten t_1 , a photodiode with a small A and large ρ should be used with a reverse voltage applied. However, this is advisable in cases where t_1 is a predominant factor affecting the response speed, so it should be noted that carrier transit time (t_3) in the depletion layer becomes slow as ρ is made large. Furthermore, applying a reverse voltage also increases dark current, so caution is necessary for use in low-light-level detection.

(2) Diffusion time t_2 of carriers generated outside the depletion layer

Carriers may be generated outside the depletion layer when incident light is absorbed by the area surrounding the photodiode photosensitive area and by the substrate section which is below the depletion layer. The time (t_2) required for these carriers to diffuse may sometimes be greater than several microseconds.

(3) Carrier transit time t_3 in the depletion layer

The transit speed (v_d) at which the carriers travel in the depletion layer is expressed using the carrier traveling rate (μ) and the electric field (E) in the depletion layer, as in $v_d = \mu E$. The average electric field is expressed using the reverse voltage (V_R) and depletion layer width (d), as in $E = V_R/d$, and thus t_3 can be approximated by equation (2-11).

$$t_3 = \frac{d}{v_d} = \frac{d^2}{\mu V_R} \dots\dots\dots (2-11)$$

To shorten t_3 , the distance traveled by carriers should be short or the reverse voltage higher. t_3 becomes slower as the resistivity is increased.

The above three factors determine the rise time of a photodiode. The rise time (t_r) is approximated by

equation (2-12).

$$tr = \sqrt{t_1^2 + t_2^2 + t_3^2} \dots\dots\dots (2-12)$$

As can be seen from equation (2-12), the factor that is slowest among the three factors becomes predominant. As stated above, t_1 and t_3 contain the factors that contradict each other. Making one faster inevitably makes the other slower, so it is essential to create a well-balanced design that matches the application. When a photodiode receives sine wave-modulated light emitted from a laser diode and the like, the cutoff frequency (f_c) is defined as the frequency at which the photodiode output drops by 3 dB relative to the 100% output level which is maintained while the sine wave frequency is increased. This is roughly approximated from the rise time (tr) as in equation (2-13).

$$f_c = \frac{0.35}{tr} \dots\dots\dots (2-13)$$

Figure 2-11 shows examples of the response waveforms and frequency characteristics for Si photodiodes.

[Figure 2-11] Examples of response waveforms and frequency characteristics

(a) Response waveforms

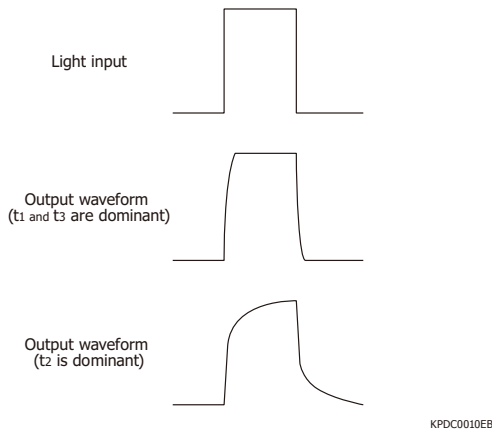

(b) Response waveform (S2386-18K)

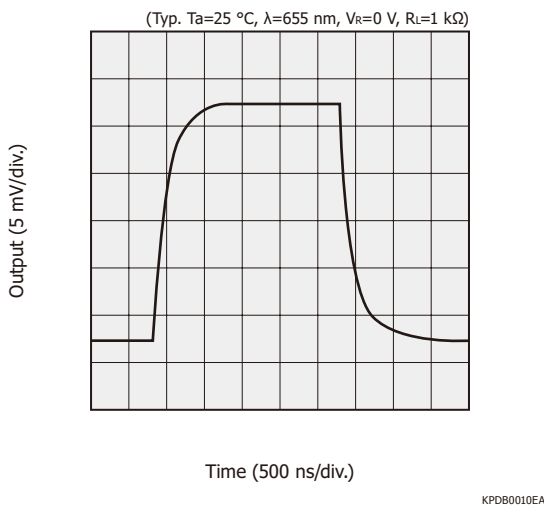

(c) Frequency characteristics (S5973)

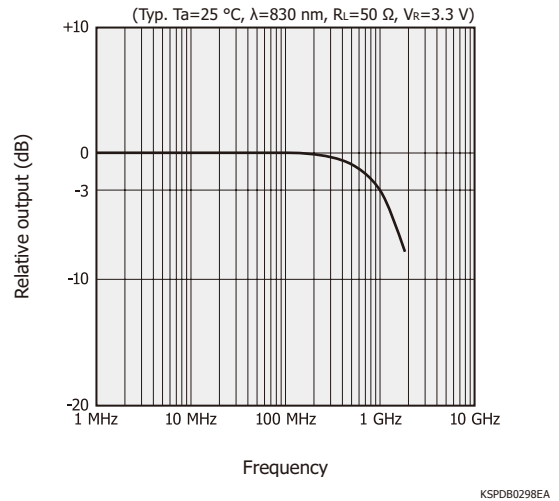

PIN photodiodes are designed such that fewer carriers are generated outside the depletion layer, the terminal capacitance is small, and the carrier transit time in the depletion layer is short. They are suited for optical communications and other applications requiring high-speed response. Hamamatsu PIN photodiodes exhibit relatively low dark current when reverse voltage is applied and have excellent voltage resistance. Figure 2-12 shows changes in the cutoff frequency with increasing reverse voltage.

[Figure 2-12] Cutoff frequency vs. reverse voltage (S5973, S9055)

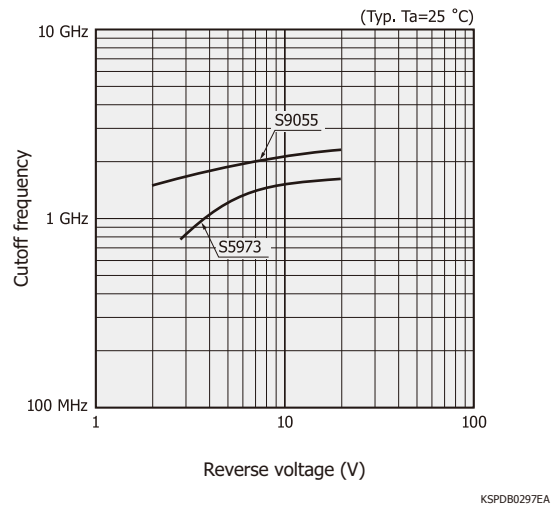
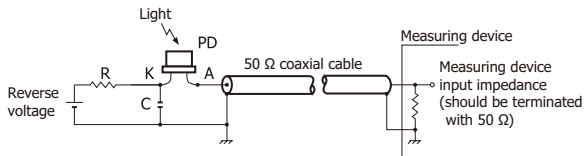

Figure 2-13 shows an example of a simple connection with 50 Ω load resistance (measurement device input impedance). The ceramic capacitor C is used to suppress ripples or noise which may occur from the reverse voltage power supply, while the resistor R is used to protect the Si photodiode. The resistor value is selected such that the extent of the voltage drop caused by the maximum photocurrent will be sufficiently smaller than the reverse voltage. The Si photodiode leads, capacitor leads, and coaxial cable wires carrying high-speed pulses should be kept as short as possible.

[Figure 2-13] Connection example of coaxial cable



PD: high-speed Si PIN photodiode (S5972, S5973, S9055, S9055-01, etc.)
 R : 10 kΩ; Voltage drop by photocurrent should be sufficiently lower than reverse voltage.
 C : 0.1 μF ceramic capacitor

KPDC0009EA

3. How to use

3-1 Connection to an op amp

» Feedback circuit

Figure 3-1 shows basic connection examples of a Si photodiode and op amp. When connected with this polarity, in the DC to low-frequency region, the output voltage V_{out} is 180 degrees out of phase with the input current (photodiode short circuit current I_{sc}) and is given by: $V_{out} = -I_{sc} \times R_f$. The feedback resistance R_f is determined by how much the input current needs to be multiplied. If, however, the feedback resistance is made greater than the photodiode shunt resistance R_{sh} , the op amp equivalent input voltage noise (e_n) and input offset voltage will be multiplied by $(1 + \frac{R_f}{R_{sh}})$ and then superimposed on the output voltage V_{out} . Moreover, the op amp's bias current error (described later) will also increase, thus making it not practical to use an infinitely large feedback resistance. If there is an input capacitance C_t , the feedback capacitance C_f prevents unstable operation of the circuit in high-frequency regions. The feedback capacitance and feedback resistance also form a lowpass filter with a time constant of $C_f \times R_f$, so their values should be chosen according to the application. When it is desired to integrate the amount of incident light in applications such as radiation detection, R_f should be removed so that the op amp and C_f act as an integrating circuit. However, a switch is required to discharge C_f in order to detect continuous signals.

[Figure 3-1] Connection examples of Si photodiode and op amp

(a)

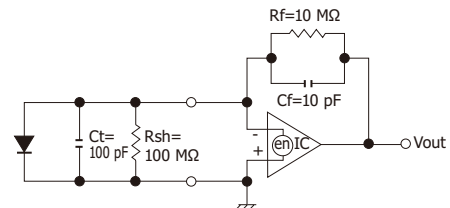

KPDC0011EA

(b)

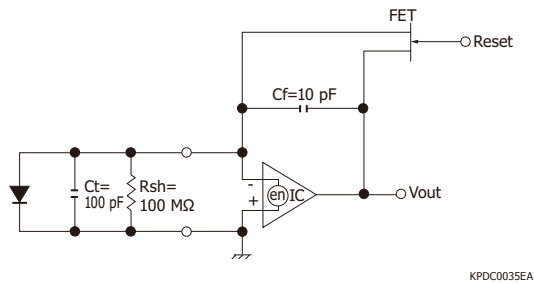

IC: op amp
en: equivalent input voltage noise of op amp

» Bias current

Since the actual input impedance of an op amp is not infinite, some bias current will flow into or out of the input terminals. This may result in error, depending on the magnitude of the detected current. The bias current which flows in an FET-input op amp is sometimes lower than 0.1 pA. Bipolar op amps, however, have bias currents ranging from several hundred picoamperes to several hundred nanoamperes. In general, the bias current of FET-input op amps doubles for every 10 °C increase in temperature, while the bias current of bipolar op amps decreases. In some cases, the use of a bipolar op amp should be considered when designing circuits for high-temperature operation. As is the case with offset voltage, the error voltage attributable to the bias current can be adjusted by means of a variable resistor connected to the offset adjustment terminals of the op amp. Leakage currents on the printed circuit board used to configure the circuit may be greater than the op amp's bias current. Besides selecting the optimal op amp, consideration must be given to the circuit pattern design and parts layout, as well as the use of guard rings and Teflon terminals.

» Gain peaking

The high-frequency response characteristics of a Si photodiode and op amp circuit are determined by the time constant $R_f \times C_f$. However, if the terminal capacitance or input capacitance is large, a phenomenon known as "gain peaking" will sometimes occur. Figure 3-2 contains examples of frequency response characteristics showing gain peaking. The output voltage increases abnormally in the high-frequency region [see the upper trace in Figure 3-2 (a)], causing significant ringing in the output voltage waveform in response to the pulsed light input [Figure 3-2 (b)]. This gain operates in the same manner with respect to op amp input noise and may result in abnormally high noise levels [see the upper trace in Figure 3-2 (c)]. This occurs at the high-frequency region when each reactance of the input capacitance and the

feedback capacitance of the op amp jointly form an unstable amplifier with respect to noise. In such a case, adverse effects on light detection accuracy may result.

[Figure 3-2] Gain peaking

(a) Frequency characteristics

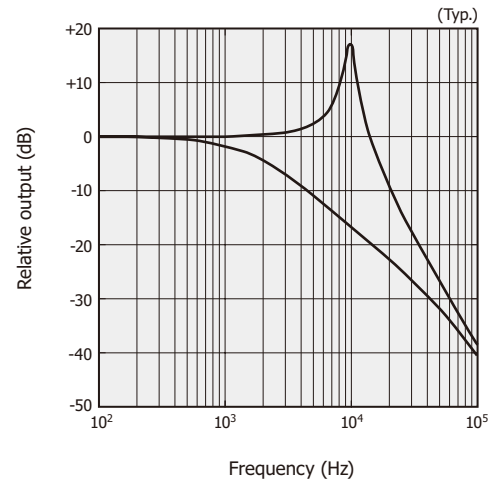

Circuit : Figure 3-1 (a) Upper trace: Cf=0 pF
Op amp : AD549 Lower trace: Cf=10 pF
Light source: 780 nm

KPDB0019EA

(b) Light pulse response (typical example)

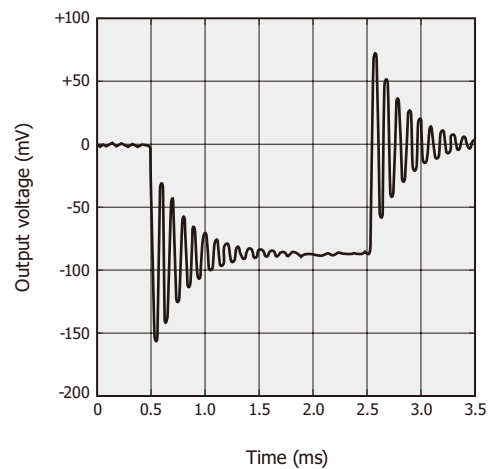

Circuit : Figure 3-1 (a) Light source: 780 nm
Op amp: AD549 Cf=0 pF

KPDB0020EA

(c) Frequency characteristics of noise output (typical example)

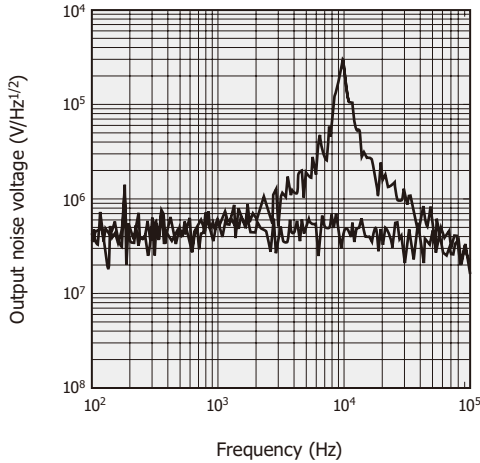

Circuit : Figure 3-1 (a) Upper trace: Cf=0 pF
Op amp: AD549 Lower trace: Cf=10 pF

KPD80021EA

» Elimination of gain peaking

To achieve a wide frequency characteristic without gain peaking and ringing phenomena, it is necessary to select the optimal relationship between the photodiode, op amp, feedback resistance, and feedback capacitance. It will prove effective in this case to reduce the terminal capacitance (C_t), as was previously explained in section 2-6, "Response speed." In the op amp, the higher the speed and the wider the bandwidth, the less the gain peaking that occurs. However, if adequate internal phase compensation is not provided, oscillation may be generated as a result. Connect the feedback elements in parallel, not only the resistance but also the feedback capacitance, in order to avoid gain peaking. The above measures can be explained as follows, using the circuit shown in Figure 3-1 (a).

As shown in Figure 3-3, the circuit gain of the op amp is determined for the low-frequency region ① simply by the resistance ratio of R_{sh} to R_f .

From the frequency $f_1 = \frac{R_{sh} + R_f}{2\pi R_{sh} R_f (C_f + C_t)}$, gain begins to increase with frequency as shown in region ②. Next, at the frequency $f_2 = \frac{1}{2\pi C_f R_f}$, and above, the circuit gain of the op amp enters a flat region ③ which is determined by the ratio of C_t and C_f . At the point of frequency f_3 where circuit gain contacts the open-loop gain line (normally, rolloff is 6 dB/octave) of the op amp, region ④ is entered. In this example, f_1 and f_2 correspond to 160 Hz and 1.6 kHz, respectively, under the circuit conditions of Figure 3-1 (a). If C_f is made 1 pF, f_2 shifts to f_2' and the circuit gain increases further. What should be noted here is that, since the setting of increasing circuit gain in region ③ exceeds the open-loop gain line of the op amp, region ③ actually does not exist. As a result, gain peaking occurs in the frequency

characteristics of the op amp circuit, and ringing occurs in the pulsed light response characteristics, then instability results [Figure 3-2].

[Figure 3-3] Graphical representation of gain peaking

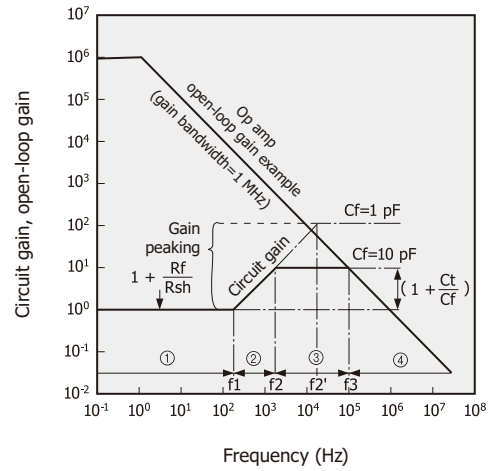

KPD80016EA

To eliminate gain peaking, take the following measures:

- (1) Determine R_f and C_f so that the flat region ③ in Figure 3-3 exists.
- (2) When f_2 is positioned to the right of the open-loop gain line of the op amp, use the op amp having a high frequency at which the gain becomes 1 (unity gain bandwidth), and set region ③.
- (3) Replace a photodiode with a low C_t value. In the example shown in Figure 3-3, $(1 + \frac{C_t}{C_f})$ should be close to 1.

The above measures (1) and (2) should reduce or prevent gain peaking and ringing. However, in the high-frequency region ③, circuit gain is present, and the input noise of the op amp and feedback resistance noise are not reduced, but rather, depending on the circumstances, may even be amplified and appear in the output. Measure (3) can be used to prevent this situation.

Using the above procedures, the S/N deterioration caused by gain peaking and ringing can usually be solved. However, regardless of the above measures, if load capacitance from several hundred picofarads to several nanofarads or more (for example, a coaxial cable of several meters or more and a capacitor) is connected to the op amp output, oscillation may occur in some types of op amps. Thus the load capacitance must be set as small as possible.

3 - 2 Application circuit examples

» Ultra-low-light detection circuit

Ultra-low-light detection circuits require measures for reducing electromagnetic noise in the surrounding area, AC noise from the power supply, and internal op amp noise, etc.

Figure 3-4 shows some measures for reducing electromagnetic noise in the surrounding area.

[Figure 3-4] Ultra-low-light sensor head

(a) Using shielded cable to connect to photodiode

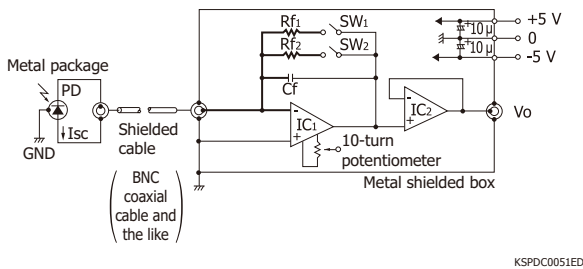

KSPDC0051ED

(b) Using metal shielded box that contains entire circuit

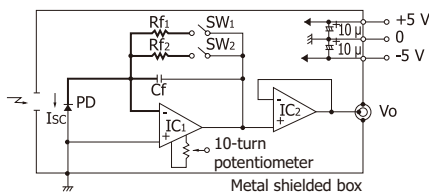

KSPDC0052EB

(c) Using optical fiber

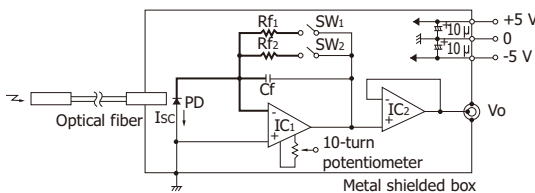

KSPDC0053EB

Bold lines should be within guarded layout or on Teflon terminals.

IC1: FET-input op amp and the like

IC2: OP07 and the like

Cf : 10 pF to 100 pF polystyrene capacitor

Rf : 10 GΩ max.

SW: reed relay or switch with low leakage current

PD : S1226/S1336/S2386 series, S2281, and the like

$V_o = I_{sc} \times R_f [V]$

Terminating the photosensitive area of the photodiode to the ground to use it as a shield layer and extracting the photodiode signal from the cathode terminal is another effective means. An effective countermeasure against AC noise from the power supply is inserting an RC filter or an LC filter in the power supply line. Using a dry cell battery for the power supply also proves effective against power supply noise. Op amp noise can be reduced by selecting an op amp having a low 1/f noise

and low equivalent input noise current. Moreover, high-frequency noise can be reduced by using a feedback capacitor (Cf) to limit the frequency bandwidth of the circuit to match the signal frequency bandwidth.

Output errors (due to the op amp input bias current and input offset voltage, routing of the circuit wiring, circuit board surface leakage current, etc.) must next be reduced. Select an FET-input op amp or a CMOS input op amp with low 1/f noise, both of which allow input bias currents below a few hundred femtoamperes. In addition, it will be effective to use an op amp that provides input offset voltages below several millivolts and has an offset adjustment terminal. Also use a circuit board made from materials having high insulation resistance. As countermeasures against current leakage from the surface of the circuit board, try using a guard pattern or aerial wiring with teflon terminals for the wiring from the photodiode to op amp input terminals and also for the feedback resistor (Rf) and feedback capacitor (Cf) in the input wiring.

Hamamatsu offers the C6386-01, C9051, and C9329 photosensor amplifiers optimized for use with photodiodes for ultra-low-light detection.

[Figure 3-5] Photosensor amplifiers

(a) C6386-01

(b) C9051



(c) C9329



Photodiodes and coaxial cables with BNC-to-BNC plugs are sold separately.

» Light-to-logarithmic voltage conversion circuit

The voltage output from a light-to-logarithmic voltage conversion circuit [Figure 3-6] is proportional to the logarithmic change in the detected light level. The log diode D for logarithmic conversion should have low dark current and low series resistance. The base-emitter (B-E) junction of a small signal transistor or the gate-source (G-S) junction of a junction FET can also be used as the log diode. I_B is the current source that supplies bias current to the log diode D and sets the circuit operating point. Unless this I_B current is supplied, the circuit will latch up when the photodiode short circuit current I_{sc} becomes zero.

[Figure 3-6] Light-to-logarithmic voltage conversion circuit

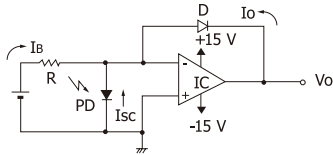

D : diode of low dark current and low series resistance
 Ib : current source for setting circuit operating point, $I_b \ll I_{sc}$
 R : 1 G Ω to 10 G Ω
 Io : saturation current of D, 10^{-15} to 10^{-12} A
 IC : FET-input op amp and the like

$$V_o \approx -0.06 \log \left(\frac{I_{sc} + I_b}{I_o} + 1 \right) \text{ [V]}$$

KPDC0021EA

» Light level integration circuit

This light level integration circuit uses an integration circuit made up of a photodiode and an op amp. This is used to measure the amount of integrated light or average amount of a light pulse train with irregular pulse heights, cycles, and widths.

The IC and C in Figure 3-7 make up the integrator that accumulates short circuit current I_{sc} generated by each light pulse in the integration capacitor C. By measuring the output voltage V_o immediately before reset, the average short circuit current can be obtained from the integration time (t_o) and the capacitance C. A low dielectric absorption type capacitor should be used as the capacitance C to eliminate reset errors. The switch SW is a CMOS analog switch.

[Figure 3-7] Light level integration circuit

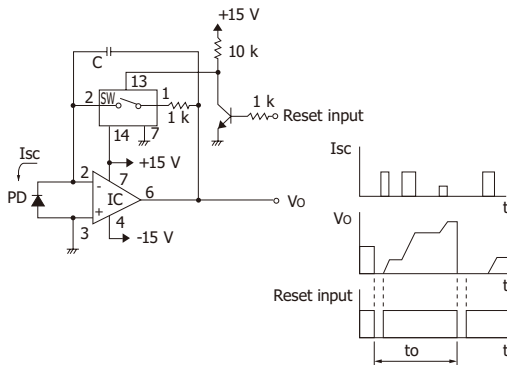

Reset input: Use TTL "low" level to reset.
 IC : LF356 and the like
 SW : CMOS 4066
 PD : S1226/S1336/S2386 series and the like
 C : polycarbonate capacitor and the like

$$V_o = I_{sc} \times t_o \times \frac{1}{C} \text{ [V]}$$

KPDC0027EB

» Simple illuminometer (1)

A simple illuminometer circuit can be configured by using the Hamamatsu C9329 photosensor amplifier and the S9219 Si photodiode with sensitivity corrected to

match human eye sensitivity. As shown in Figure 3-8, this circuit can measure illuminance up to a maximum of 1000 lx by connecting the output of the C9329 to a voltmeter in the 1 V range via an external resistive voltage divider.

A standard light source is normally used to calibrate this circuit, but if not available, then a simple calibration can be performed with a 100 W white light source.

To calibrate this circuit, first select the L range on the C9329 and then turn the variable resistor VR clockwise until it stops. Block the light to the S9219 while in this state, and rotate the zero adjustment knob on the C9329 so that the voltmeter reads 0 V. Next turn on the white light source, and adjust the distance between the white light source and the S9219 so that the voltmeter display shows 0.225 V. (The illuminance on the S9219 surface at this time is approx. 100 lx.) Then turn the VR counterclockwise until the voltmeter display shows 0.1 V. The calibration is now complete.

After calibration, the output should be 1 mV/lx in the L range, and 100 mV/lx in the M range on the C9329.

[Figure 3-8] Simple illuminometer (1)

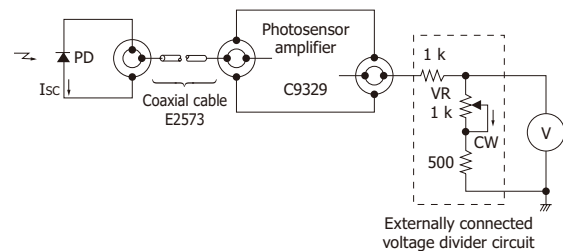

PD: S9219 (4.5 μ A/100 lx)

KSPDC0054EB

» Simple illuminometer (2)

This is a simple illuminometer circuit using an op amp current-voltage conversion circuit and the S7686 Si photodiode with sensitivity corrected to match human eye sensitivity. This circuit can measure illuminance up to a maximum of 10000 lx by connecting to a voltmeter in the 1 V range.

Use a low current consumption type op amp that operates from a single power supply and allows low input bias currents. A simple calibration can be performed using a 100 W white light source.

To calibrate this circuit, first select the 10 mV/lx range and short the op amp output terminal to the sliding terminal of the variable resistor for meter calibration. Next turn on the white light source, and adjust the distance between the white light source and the S7686 so that the voltmeter reads 0.45 V. (The illuminance on the S7686 surface at this time is approx. 100 lx.) Then adjust the variable resistor for meter calibration until the voltmeter reads 1 V. The calibration is now complete.

[Figure 3-9] Simple illuminometer (2)

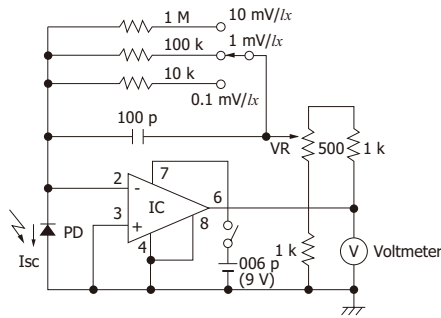

VR: variable resistor for meter calibration
 IC : TLC271 and the like
 PD: S7686 (0.45 μ A/100 lx)

KPDC0018EE

» Light balance detection circuit

Figure 3-10 shows a light balance detector circuit utilizing two Si photodiodes, PD₁ and PD₂, connected in reverse-parallel and an op amp current-voltage converter circuit. The photosensitivity is determined by the value of the feedback resistance R_f. The output voltage V_o becomes zero when the light levels incident on PD₁ and PD₂ are equal. Since two diodes D are connected in reverse in parallel, V_o will be limited to about ± 0.5 V when the light levels on PD₁ and PD₂ are in an unbalanced state, so that only the light level near a balanced state can be detected with high sensitivity. If a filter is used, this circuit can also be utilized to detect a light level balance in specific wavelength regions.

[Figure 3-10] Light balance detection circuit

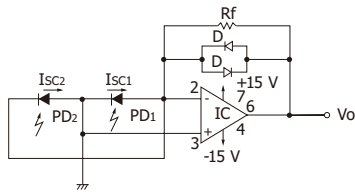

PD: S1226/S1336/S2386 series and the like
 IC : LF356 and the like
 D : ISS226 and the like

$$V_o = R_f \times (I_{sc2} - I_{sc1}) \text{ [V]}$$

(Note that V_o is within ± 0.5 V.)

KPDC0017EB

» Absorptiometer

This is a light absorption meter that obtains a logarithmic ratio of two current inputs using a dedicated IC and two Si photodiodes [Figure 3-11]. By measuring the light level of the light source and the light level transmitting through a sample using two Si photodiodes and then comparing them, light absorbance by the sample can be measured.

To make measurements, the optical system such as an aperture diaphragm should first be adjusted so that the short circuit currents of the two Si photodiodes are equal and the output voltage V_o is set to 0 V. Next, the sample is placed on the light path of one photodiode. The output voltage at this point indicates the absorbance of the sample. The relation between the absorbance A and the output voltage V_o is expressed by $A = -V_o$ [V].

If necessary, a filter is placed in front of the light source as shown in Figure 3-11 in order to measure the spectral absorbance of a specific wavelength region or monochromatic light.

[Figure 3-11] Absorptiometer

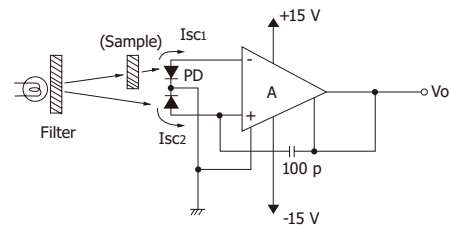

A : log amp
 PD: S5870 and the like

$$V_o = \log (I_{sc1}/I_{sc2}) \text{ [V]}$$

KPDC0025EC

» Total emission measurement of LED

Since the emitting spectral width of LED is usually as narrow as dozens of nanometers, the amount of the LED emission can be calculated from the Si photodiode photosensitivity at a peak emission wavelength of the LED. In Figure 3-12, the inner surface of the reflector block B is mirror-processed and reflects the light emitted from the side of the LED toward the Si photodiode, so that the total amount of the LED emission can be detected by the Si photodiode.

[Figure 3-12] Total emission measurement of LED

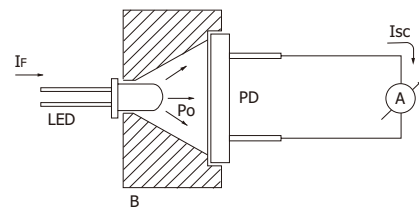

A : ammeter, 1 mA to 10 mA
 PD: S2387-1010R
 B : aluminum block with inner surface gold-plated
 S : Si photodiode photosensitivity
 See characteristics table in our datasheet.
 S2387-1010R: S \approx 0.58 A/W at 930 nm
 Po : total amount of emission

$$P_o \approx \frac{I_{sc}}{S} \text{ [W]}$$

KPDC0026EA

» High-speed light detection circuit (1)

This is a high-speed light detection circuit using a low-capacitance Si PIN photodiode with a reverse voltage applied and a high-speed op amp current-voltage converter circuit [Figure 3-13]. The frequency band of this circuit is limited by the op amp device characteristics to less than about 100 MHz.

When the frequency band exceeds 1 MHz in this circuit, the lead inductance of each component and stray capacitance from feedback resistance R_f exert drastic effects on device response speed. That effect can be suppressed by using chip components to reduce the component lead inductance, and connecting multiple resistors in series to reduce stray capacitance.

The photodiode leads should be kept as short as possible, and the pattern wiring to the op amp should be made as short and thick as possible. This will lower the effects from the stray capacitance and inductance occurring on the circuit board pattern of the op amp inputs and also alleviate effects from photodiode lead inductance. To enhance device performance, a ground plane structure using the entire surface of the board copper plating as the ground potential will be effective. A ceramic capacitor should be used for the $0.1 \mu\text{F}$ capacitor connected to the op amp power line, and it should be connected to the nearest ground point in the shortest distance.

Hamamatsu provides the C8366 photosensor amplifier for PIN photodiodes with a frequency bandwidth up to 100 MHz.

[Figure 3-13] High-speed light detection circuit (1)

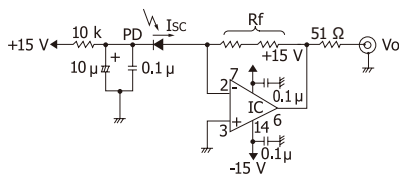

PD: high-speed PIN photodiode (S5971, S5972, S5973, etc.)
 R_f : Two or more resistors are connected in series to eliminate parallel capacitance.
 IC: AD745, LT1360, HA2525, etc.

$$V_o = -I_{sc} \times R_f [V]$$

KPDC0020ED

[Figure 3-14] Photosensor amplifier C8366

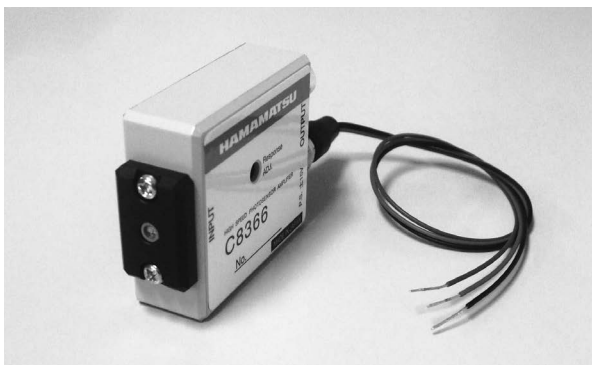

» High-speed light detection circuit (2)

This high-speed light detection circuit [Figure 3-15] uses load resistance R_L to convert the short circuit current from a low-capacitance Si PIN photodiode (with a reverse voltage applied) to a voltage, and amplifies the voltage with a high-speed op amp. In this circuit, there is no problem with gain peaking due to phase shifts in the op amp. A circuit with a frequency bandwidth higher than 100 MHz can be fabricated by selecting the correct op amp. Points for caution in the components, pattern, and structure are the same as those listed for the “High-speed light detection circuit (1).”

[Figure 3-15] High-speed light detection circuit (2)

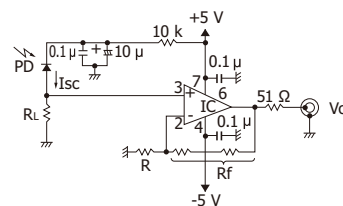

PD : high-speed PIN photodiode
 (S5971, S5972, S5973, S9055, S9055-01, etc.)
 R_L , R , R_f : adjusted to meet the recommended conditions of op amp
 IC : AD8001 and the like

$$V_o = I_{sc} \times R_L \times \left(1 + \frac{R_f}{R}\right) [V]$$

KPDC0015EE

» AC light detection circuit (1)

This is an AC light detection circuit [Figure 3-16] that uses load resistance R_L to convert the photocurrent from a low-capacitance Si PIN photodiode (with a reverse voltage applied) to a voltage, and amplifies the voltage with a high-speed op amp. In this circuit, there is no problem with gain peaking due to phase shifts in the op amp. A circuit with a frequency bandwidth higher than 100 MHz can be fabricated by selecting the correct op amp.

Points for caution in the components, pattern, and structure are the same as those listed for the “High-speed light detection circuit (1).”

[Figure 3-16] AC light detection circuit (1)

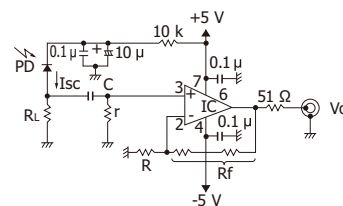

PD : high-speed PIN photodiode
 (S5971, S5972, S5973, S9055, S9055-01, etc.)
 R_L , R , R_f , r : adjusted to meet the recommended conditions of op amp
 IC : AD8001 and the like

$$V_o = I_{sc} \times R_L \times \left(1 + \frac{R_f}{R}\right) [V]$$

KPDC0034EA

» AC light detection circuit (2)

This AC light detection circuit utilizes a low-capacitance PIN photodiode with a reverse voltage applied and an FET serving as a voltage amplifier [Figure 3-17]. Using a low-noise FET allows producing a small and inexpensive low-noise circuit, which can be used in light sensors for FSP (free space optics), optical remote control, etc. In Figure 3-17, the signal output is taken from the FET drain. However, to interface to a next-stage circuit having low input resistance, the signal output should be taken from the source or a voltage-follower should be added.

[Figure 3-17] AC light detection circuit (2)

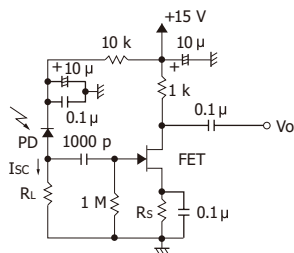

PD : high-speed PIN photodiode (S2506-02, S5971, S5972, S5973, etc.)
 RL : determined by photodiode sensitivity and terminal capacitance
 Rs : determined by FET operating point
 FET: 2SK362 and the like

KPDC0014EE

4. Applications

4 - 1 Particle size analyzers (laser diffraction and scattering method)

The laser diffraction and scattering method is a particle size measurement technique offering features such as a short measurement time, good reproducibility, and measurement of the flowing particles. Irradiating a laser beam (monochrome collimated beam) onto the particles for measurement generates a light level distribution pattern from spatially diffracted and scattered light. This distribution pattern changes with the size of the particles. Large area sensors with high resolution are needed to detect the diffracted and scattered light.

Hamamatsu multi-element Si photodiodes have superb sensitivity and small characteristic variations between elements. These photodiodes are manufactured using our sophisticated “large chip mounting/processing” technology. Many of them are used in sensor units (forward diffracted/scattered light sensors & side and back scattering light sensors) which are the core of the particle size analyzers. These photodiodes are also incorporated in particle size analyzers capable of measuring particles from 10 nm to 300 μm, and so are used for environmental measurements.

[Figure 4-1] Structure of particle size analyzer
(laser diffraction and scattering method)

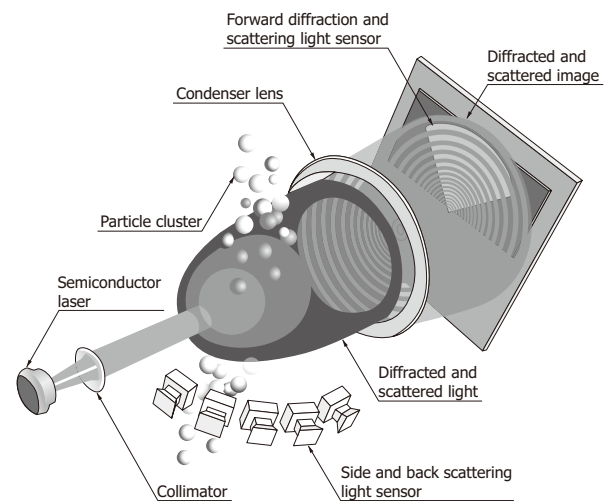

KSPDC0056EA

4 - 2 Barcode readers

In a barcode reader, the light source such as an LED or laser diode emits light onto the barcode surface, and the lens focuses the light reflected from that surface, which is then detected by the photosensor.

The detected pattern is compared with the registered patterns and then decoded into characters and numbers, etc.

The photosensor in the barcode reader must have high-speed response and high sensitivity, and it must also be able to detect the reflected light accurately. Hamamatsu Si PIN photodiodes meet all these needs, and their photosensitive area has small variations in sensitivity and so can detect light with high stability at any position on the photosensitive area. Hamamatsu also uses advanced technologies for mounting filters that block extraneous light and mounting components in a compact manner, which help reduce the size of barcode readers.

4 - 3 UV sensors

Ultraviolet light is high in energy and exhibits sterilizing effects and photocatalysis. On the other hand, ultraviolet rays deteriorate the materials that absorb them.

Si photodiodes also have high sensitivity in the ultraviolet region and so are widely used for detecting ultraviolet light. For example, a product consisting of Si photodiode and ultraviolet monochromatic band-pass filters mounted in the highly reliable package is widely used in devices that detect organic contamination, which is a kind of water pollution.

Sensitivity may degrade as a result of received ultraviolet light reacting with the outgas that is emitted from the resin in the package depending on the operating environment. Hamamatsu has also developed packaging technology that does not use resin and Si photodiode chips highly resistant to ultraviolet light. These are used to produce high-reliability UV Si photodiodes.

4 - 4 Rotary encoders

Rotary encoders are widely used in FA (factory automation) and industrial control equipment. Rotary encoders contain a rotary slit disk and fixed slit plate between a light emitter and a photosensor (photodiode). The rotation of the rotary slit disk serves to pass or block light from the light emitter, and changes in this light are detected by the photosensor as rotations.

The photosensor must have high-speed response and high chip position accuracy in order to convert the number of shaft rotations (analog values) into pulses (digital values). Multi-element Si PIN photodiodes made by Hamamatsu are suitable for detecting high-speed changes in the optical signal. These photosensors deliver stable detection because there is small variation in sensitivity and response speed between elements.

To ensure low photosensor noise, patterning technology may be applied to block light to sections other than the photosensitive areas.

[Figure 4-2] Example of rotary encoder structure

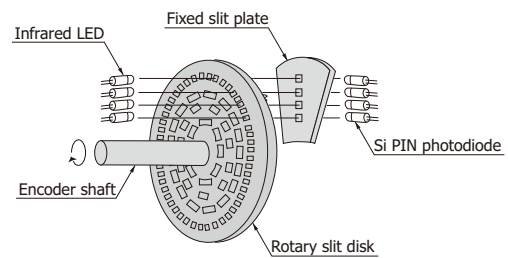

KSPDC0062EA

4 - 5 Color sensors

Separately detecting the three primary colors of light, which are red (R), green (G), and blue (B) color signals, not only simplifies color identification but also makes it possible to authenticate paper money, identify paint colors, and manage printed matter and textile product colors, and so on. Si photodiodes have sensitivity over a wide wavelength range. However, combining them with filters allows detecting the individual RGB wavelengths. Hamamatsu Si photodiodes for RGB color sensors are small since each of the RGB sensors is integrated on the same chip and allows easy detection of color signals.

4 - 6 VICS (Vehicle Information and Communication System)

VICS is a system used in Japan for providing information such as traffic congestion, road construction, traffic regulations, and required time, etc. by media such as FM multiplex broadcasts, radio waves, and light.

Information supplied by light (optical media) makes use of optical beacons (in-vehicle devices) mounted in the vehicle and optical beacons (roadside devices) mounted at major points on the road to carry out two-way communication by near infrared light. One advantage of this method is that unlike other communication media, information can be exchanged in both directions. A disadvantage however is that only pinpoint information can be provided since the communication area is limited. The uplink (in-vehicle device → roadside device) communication range is different from the downlink (roadside device → in-vehicle device) range.

[Figure 4-3] Optical beacons used by VICS

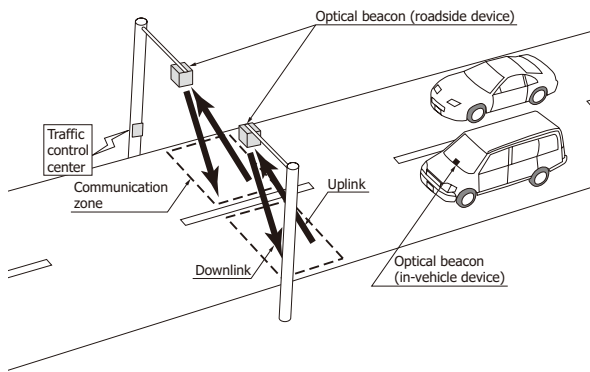

KLEDC0029EA

The optical beacon contains an LED and a photodiode. The in-vehicle device must be compact to avoid installation space problems and uses a surface mount type photodiode. The in-vehicle device will have to operate under harsh environmental conditions, so the design specifications must allow for a wider operating and storage temperature range than in ordinary photodiodes.

In early-stage VICS systems, the LED array and the photodiode were almost always mounted separately. Currently, however, both are integrated into one compact device [Figure 4-4].

[Figure 4-4] Light emitting/receiving module P12793 for VICS

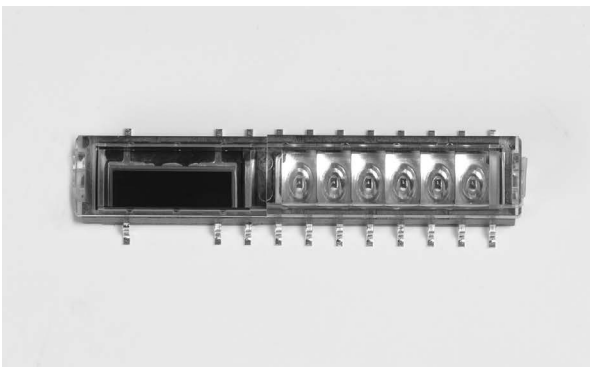

Information described in this material is current as of May 2022.

Product specifications are subject to change without prior notice due to improvements or other reasons. This document has been carefully prepared and the information contained is believed to be accurate. In rare cases, however, there may be inaccuracies such as text errors. Before using these products, always contact us for the delivery specification sheet to check the latest specifications.

The product warranty is valid for one year after delivery and is limited to product repair or replacement for defects discovered and reported to us within that one year period. However, even if within the warranty period we accept absolutely no liability for any loss caused by natural disasters or improper product use. Copying or reprinting the contents described in this material in whole or in part is prohibited without our prior permission.

HAMAMATSU

www.hamamatsu.com

HAMAMATSU PHOTONICS K.K., Solid State Division

1126-1 Ichino-cho, Higashi-ku, Hamamatsu City, 435-8558 Japan, Telephone: (81)53-434-3311, Fax: (81)53-434-5184

U.S.A.: HAMAMATSU CORPORATION: 360 Foothill Road, Bridgewater, NJ 08807, U.S.A., Telephone: (1)908-231-0960, Fax: (1)908-231-1218 E-mail: usa@hamamatsu.com

Germany: HAMAMATSU PHOTONICS DEUTSCHLAND GMBH.: Arzbergerstr. 10, 82211 Herrsching am Ammersee, Germany, Telephone: (49)8152-375-0, Fax: (49)8152-265-8 E-mail: info@hamamatsu.de

France: HAMAMATSU PHOTONICS FRANCE S.A.R.L.: 19, Rue du Saule Trapu, Parc du Moulin de Massy, 91882 Massy Cedex, France, Telephone: (33)1 69 53 71 00, Fax: (33)1 69 53 71 10 E-mail: infos@hamamatsu.fr

United Kingdom: HAMAMATSU PHOTONICS UK LIMITED: 2 Howard Court, 10 Tewin Road, Welwyn Garden City, Hertfordshire AL7 1BW, UK, Telephone: (44)1707-294888, Fax: (44)1707-325777 E-mail: info@hamamatsu.co.uk

North Europe: HAMAMATSU PHOTONICS NORDEN AB: Torshamnsgatan 35 16440 Kista, Sweden, Telephone: (46)8-509 031 00, Fax: (46)8-509 031 01 E-mail: info@hamamatsu.se

Italy: HAMAMATSU PHOTONICS ITALIA S.R.L.: Strada della Moia, 1 int. 6, 20044 Arese (Milano), Italy, Telephone: (39)02-93 58 17 33, Fax: (39)02-93 58 17 41 E-mail: info@hamamatsu.it

China: HAMAMATSU PHOTONICS (CHINA) CO., LTD.: 1201 Tower B, Jiaming Center, 27 Dongsanhuan Beilu, Chaoyang District, 100020 Beijing, P.R. China, Telephone: (86)10-6586-6006, Fax: (86)10-6586-2866 E-mail: hpc@hamamatsu.com.cn

Taiwan: HAMAMATSU PHOTONICS TAIWAN CO., LTD.: 8F-3, No.158, Section 2, Gongdao 5th Road, East District, Hsinchu, 300, Taiwan R.O.C. Telephone: (886)3-659-0080, Fax: (886)3-659-0081 E-mail: info@hamamatsu.com.tw

Cat. No. KSPD9001E02 May 2022 DN