

Mini-spectrometer



[**Micro series**]

C12880MA

Fingertip sized, ultra-compact spectrometer head supporting high sensitivity and long wavelength region

The C12880MA is a high-sensitivity, ultra-compact (fingertip sized) spectrometer head that supports the long wavelength region (up to 850 nm). Hermetically sealed packaging provides improved humidity resistance. This product is suitable for integration into a variety of compact devices.

Features

- **Fingertip size: 20.1 × 12.5 × 10.1 mm**
- **Weight: 5 g**
- **Spectral response range: 340 to 850 nm**
- **High sensitivity**
- **Spectral resolution: 15 nm max.**
- **Supports synchronized integration (electronic shutter function)**
- **Hermetic package: high reliability against humidity**
- **For integration into mobile measurement equipment**
- **Wavelength conversion factors^{*1} are listed on final inspection sheet.**

*1: Conversion factors for converting the image sensor pixel number into a wavelength. A calculation factor for converting the A/D converted count into the input light level is not provided.

Applications

- **Food inspection**
- **Biometry (POC)**
- **Tester for lights, LEDs, etc.**
- **Water quality control monitors and other environment measuring instruments**
- **Various light level measurements**

Structure

Parameter	Specification	Unit
Image sensor	High-sensitivity CMOS linear image sensor with slit	-
Number of pixels	288	pixels
Pixel size (H × V)	14 × 200	μm
Slit*2 (H × V)	50 × 500	μm
NA*3	0.22	-
Dimensions (W × D × H)	20.1 × 12.5 × 10.1	mm
Weight	5	g

*2: Entrance slit aperture size

*3: Numeric aperture (solid angle)

Absolute maximum ratings (Ta=25 °C unless otherwise noted)

Parameter	Symbol	Condition	Value	Unit
Supply voltage	Vs max		-0.3 to +6	V
Clock pulse voltage	V(CLK)		-0.3 to +6	V
Start pulse voltage	V(ST)		-0.3 to +6	V
Operating temperature	Topr	No dew condensation*4	+5 to +50	°C
Storage temperature	Tstg	No dew condensation*4	-20 to +70	°C

*4: When there is a temperature difference between a product and the surrounding area in high humidity environment, dew condensation may occur on the product surface. Dew condensation on the product may cause deterioration in characteristics and reliability.

Note: Exceeding the absolute maximum ratings even momentarily may cause a drop in product quality. Always be sure to use the product within the absolute maximum ratings.

▣ Recommended terminal voltage (Ta=25 °C)

Parameter	Symbol	Min.	Typ.	Max	Unit
Supply voltage	Vs	4.75	5	5.25	V
Clock pulse voltage	High level	3	Vs	Vs + 0.25	V
	Low level	0	-	0.3	
Start pulse voltage	High level	3	Vs	Vs + 0.25	V
	Low level	0	-	0.3	

▣ Electrical characteristics [Ta=25 °C, Vs=5 V, V(CLK)=V(ST)=5 V]

Parameter	Symbol	Min.	Typ.	Max	Unit
Clock pulse frequency	f(CLK)	0.2	-	5	MHz
Video rate	VR	-	f(CLK)	-	Hz
Output impedance*5	Zo	-	150	-	Ω
Current consumption*6	I	-	20	-	mA

*5: Video signal output terminal (10-pin)

An increase in the current consumption at the video output terminal also increases the chip temperature and so causes the dark current to rise. To avoid this, connect a buffer amplifier to the video output terminal so that the current flow is minimized.

*6: f(CLK)=5 MHz

▣ Electrical and optical characteristics [Ta=25 °C, Vs=5 V, V(CLK)=V(ST)=5 V]

Parameter	Symbol	Min.	Typ.	Max	Unit
Conversion efficiency	CE	-	50	-	μV/e ⁻
Dark output voltage*7	Vd	-	0.8	8.0	mV
Saturation output voltage*8	Vsat	-	4.3	-	V
Readout noise	Nr	-	1.8	3.6	mV rms
Output offset voltage	Vo	0.3	0.5	0.9	V
Spectral response range	λ	-	340 to 850	-	nm
Spectral resolution (FWHM)	-	-	12	15	nm
Wavelength reproducibility*9	λr	-0.5	-	+0.5	nm
Wavelength temperature dependence	λTd	-0.1	-	+0.1	nm/°C
Spectral stray light*10	SL	-	-	-25	dB

*7: Integration time=10 ms

*8: Relative value in reference to output offset voltage Vo

Example: When output offset voltage Vo is 0.5 V and saturation output voltage Vsat is 4.3 V, the saturation voltage at the video signal output terminal is 4.8 V.

*9: Measured under constant light input conditions

*10: The ratio of the output signal when a light spectrum (655 nm) is input to the output signal at that wavelength ± 40 nm

Optical component layout

Besides a CMOS image sensor chip integrated with an optical slit by etching technology, the C12880MA employs a reflective concave blazed grating formed by nanoimprint. In addition, the glass used in the light path of the previous C10988MA-01 is not used in the C12880MA, making it extremely compact.

Structure

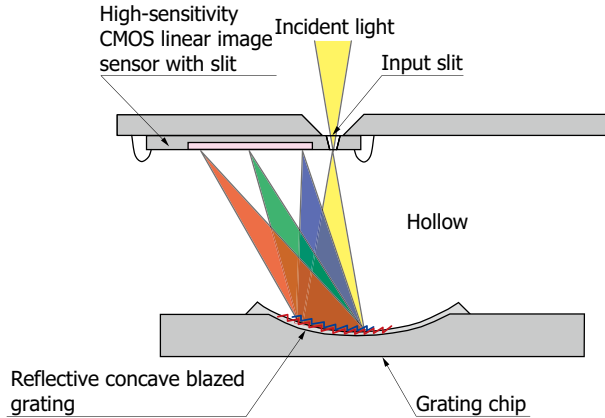

KACCC0757EB



High-sensitivity CMOS linear image sensor with a slit [Incident light side (back of chip)]

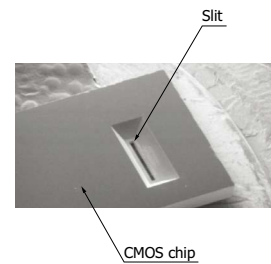

Spectral response (typical example)

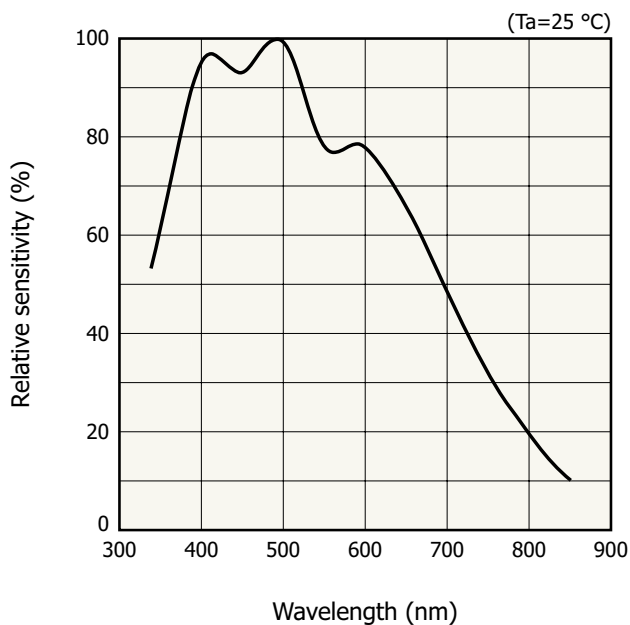

KACCB0381EA

Spectral resolution vs. wavelength (typical example)

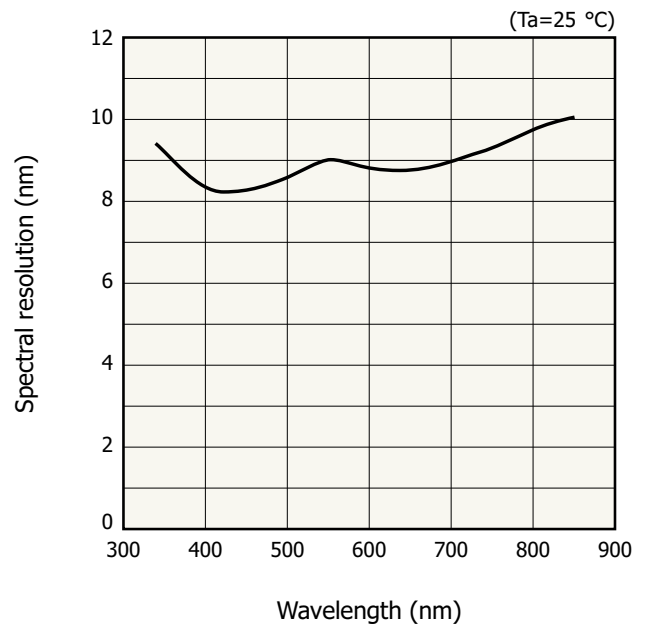

KACCB0382EA

Linearity (typical example)

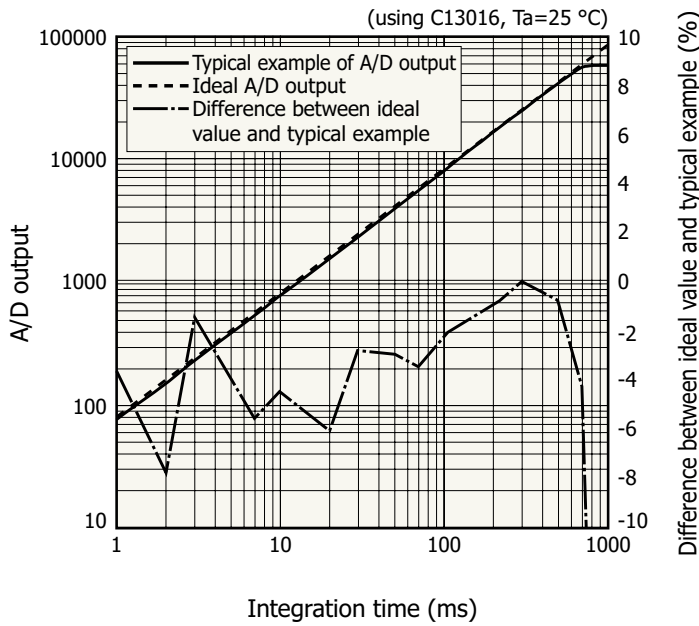

KACCB0383EB

A/D output is the output with dark output is subtracted when light is input. The difference between the ideal value and typical example contains a measurement error. The smaller the A/D output, the larger the measurement error.

Dark output vs. ambient temperature (typical example)

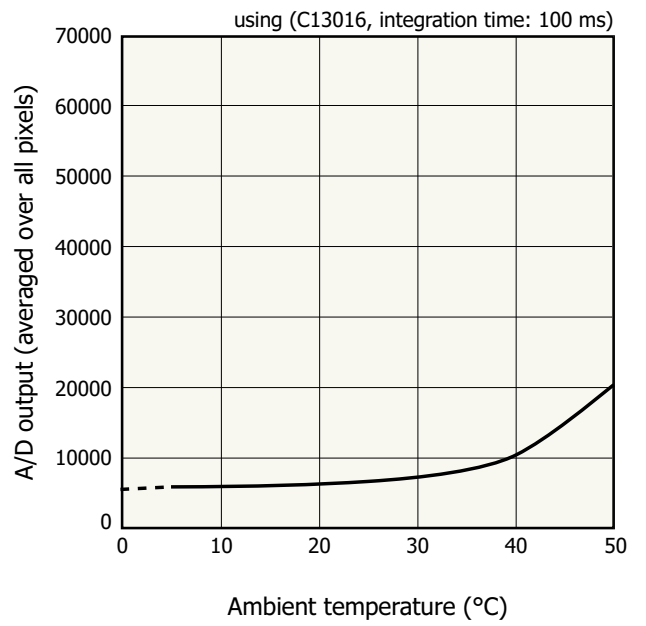

KACCB0384EA

A/D output is the sum of the sensor and circuit offset outputs and the sensor dark output.

Measurable incident light level

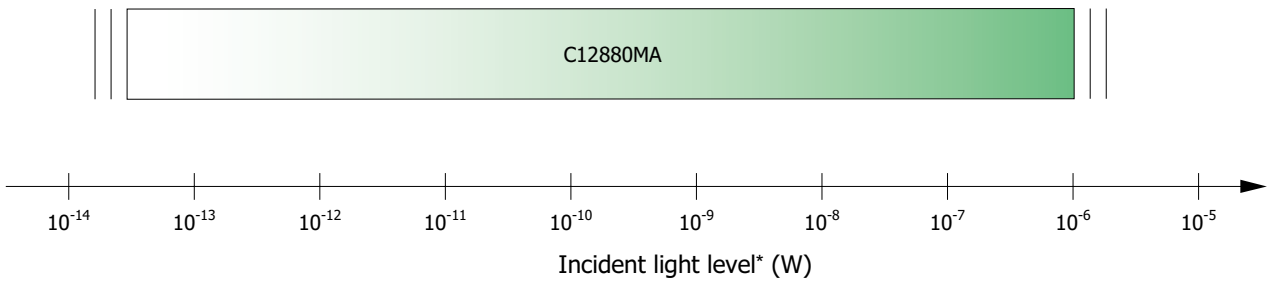

* Using C13016, input spot diameter 800 μm ($\lambda=600\text{ nm}$)

KACCB385EA

Recommended driver circuit example

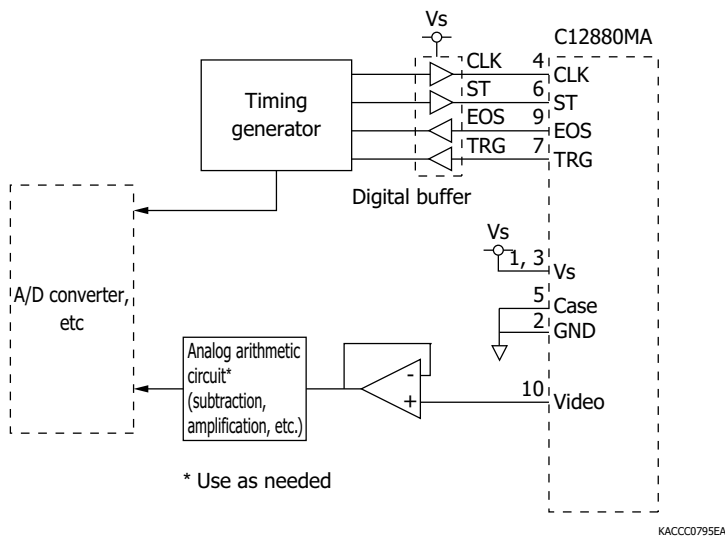

Precautions

- The packaging of the C12880MA is electrically conductive, so be careful when designing the circuit to avoid short circuit caused by contact with a circuit pattern.
- If external force is repeatedly applied to the lead pins, this may damage the lead pins.
- To prevent damage due to soldering, be careful of the soldering temperature and time.
As a general guide, finish soldering within 3.5 seconds at 350 °C or less when soldering by hand, or within 10 seconds at 260 °C or less when using a solder bath.

Dimensional outline
(unit: mm, tolerance unless otherwise noted: ± 0.2)

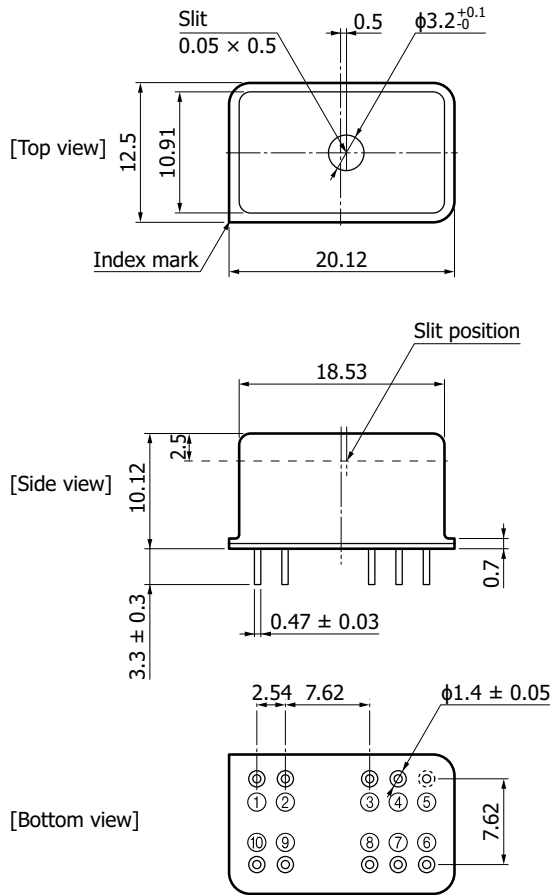

Enlarged view of slit (unit: mm)

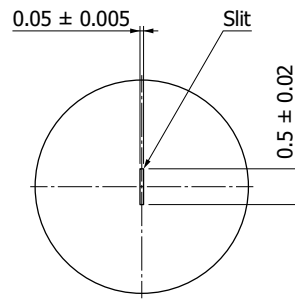

KACCA0473EA

- ① +Vs (+5 V)
- ② GND
- ③ +Vs (+5 V)
- ④ CLK
- ⑤ Case
- ⑥ ST
- ⑦ TRG
- ⑧ -
- ⑨ EOS
- ⑩ Video

KACCA0356EB

Pin connections

Make electrical connections to an external circuit using leads.

Pin no.	Symbol	Name	I/O	Description
1	+Vs	Supply voltage	I	Sensor power supply: 5 V
2	GND	Ground	-	Sensor ground
3	+Vs	Supply voltage	I	Sensor power supply: 5 V
4	CLK	Clock pulse	I	Sensor clock pulse
5	Case	Case	-	Case connection
6	ST	Start pulse	I	Sensor start pulse
7	TRG	Trigger pulse	O	Pulse for capturing sensor video signals
8	-	Fastening pin	-	Do not connect electrically.
9	EOS	End of scan	O	Sensor scan end
10	Video	Video output	O	Sensor video output

Note: Pin no. 5 and the case of the micro-spectrometer are at the same potential. Ensure that the case is not in contact with other potentials during use. Parts coming in contact with the case must be set at the same potential as pin no. 5 or insulated from other potentials.

Timing chart

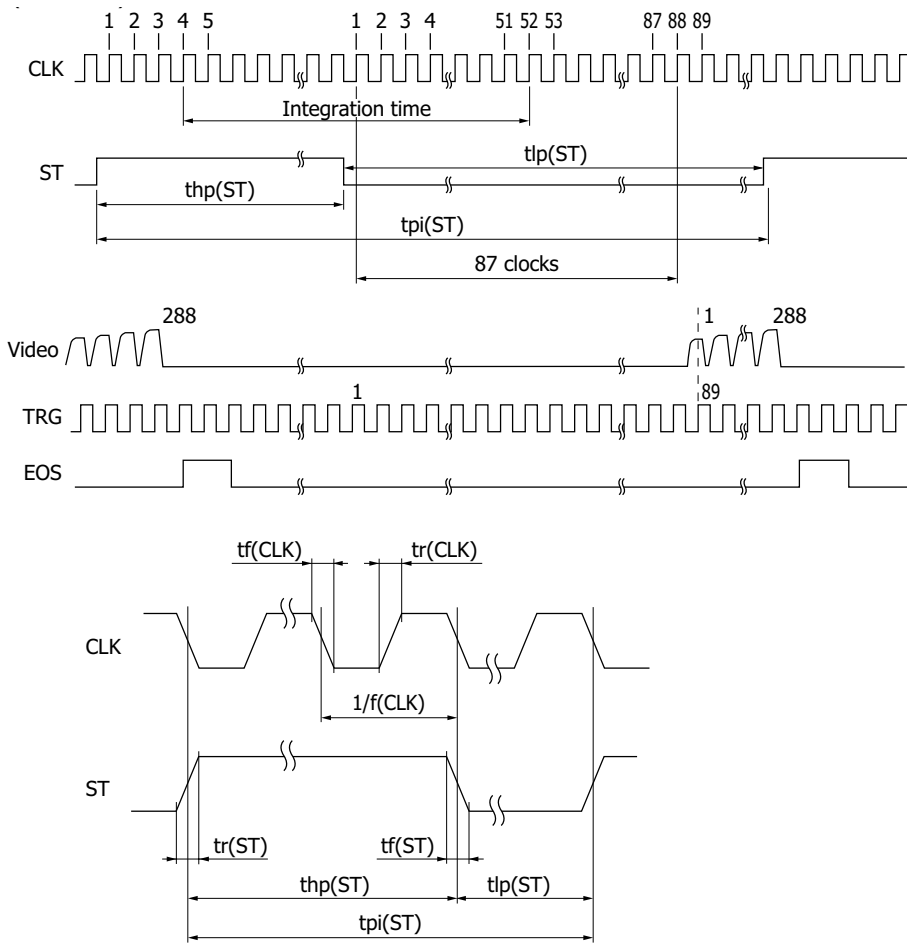

KACCC0771EA

Parameter	Symbol	Min.	Typ.	Max.	Unit
Start pulse cycle*11	t _{pi} (ST)	381/f(CLK)	-	-	s
Start pulse high period*12	t _{hp} (ST)	6/f	-	-	s
Start pulse low period	t _{lp} (ST)	375/f	-	-	s
Start pulse rise and fall times	t _r (ST), t _f (ST)	0	10	30	ns
Clock pulse duty	-	45	50	55	%
Clock pulse rise and fall times	t _r (CLK), t _f (CLK)	0	10	30	ns

*11: The shortest period required to output the video signals from all pixels.

*12: The integration time equals the high period of ST plus 48 CLK cycles.

The shift register starts operation at the rising edge of CLK immediately after ST goes low.

The integration time can be changed by changing the ratio of the high and low periods of ST.

If the first TRG pulse after ST goes low is counted as the first pulse, the Video signal should be acquired at the rising edge of the 89th TRG pulse.

Do not use the video signal read at the first ST immediately after the power supply voltage (+Vs) is input.

❏ Operation example

This is an operating example when the clock pulse frequency is set to maximum (video data rate is also set to maximum), the time per scan to minimum, and the integration time to maximum.

- Clock pulse frequency $[f(\text{CLK})] = \text{Video data rate}$
 $= 5 \text{ MHz}$
- Start pulse cycle $[t_{\text{pi}}(\text{ST})] = 381/f(\text{CLK})$
 $= 381/5 \text{ MHz}$
 $= 76.2 \mu\text{s}$
- Low period of start pulse min. $[t_{\text{lp}}(\text{ST})] = 375/f(\text{CLK})$
 $= 375/5 \text{ MHz}$
 $= 75 \mu\text{s}$
- High period of start pulse $[t_{\text{hp}}(\text{ST})] = \text{Start pulse cycle } [t_{\text{pi}}(\text{ST})] - \text{Low period of start pulse min. } [t_{\text{lp}}(\text{ST})]$
 $= 76.2 \mu\text{s} - 75 \mu\text{s}$
 $= 1.2 \mu\text{s}$

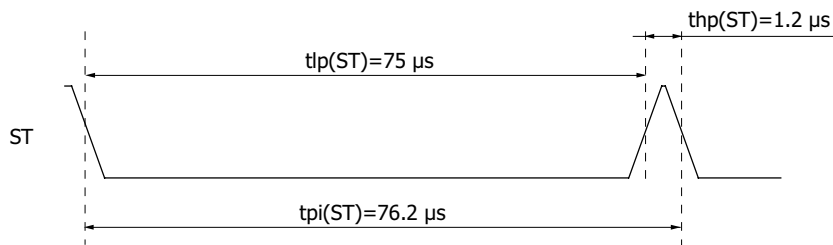

KACCC0772EA

Integration time is equal to the high period of start pulse + 48 cycles of clock pulses, so it will be $1.2 \mu\text{s} + 9.6 \mu\text{s} = 10.8 \mu\text{s}$.

Selection chart

A mini-spectrometer with SMA connector (for optical fiber connection), an evaluation circuit, and a driver circuit are available as related products for the mini-spectrometer (micro series).

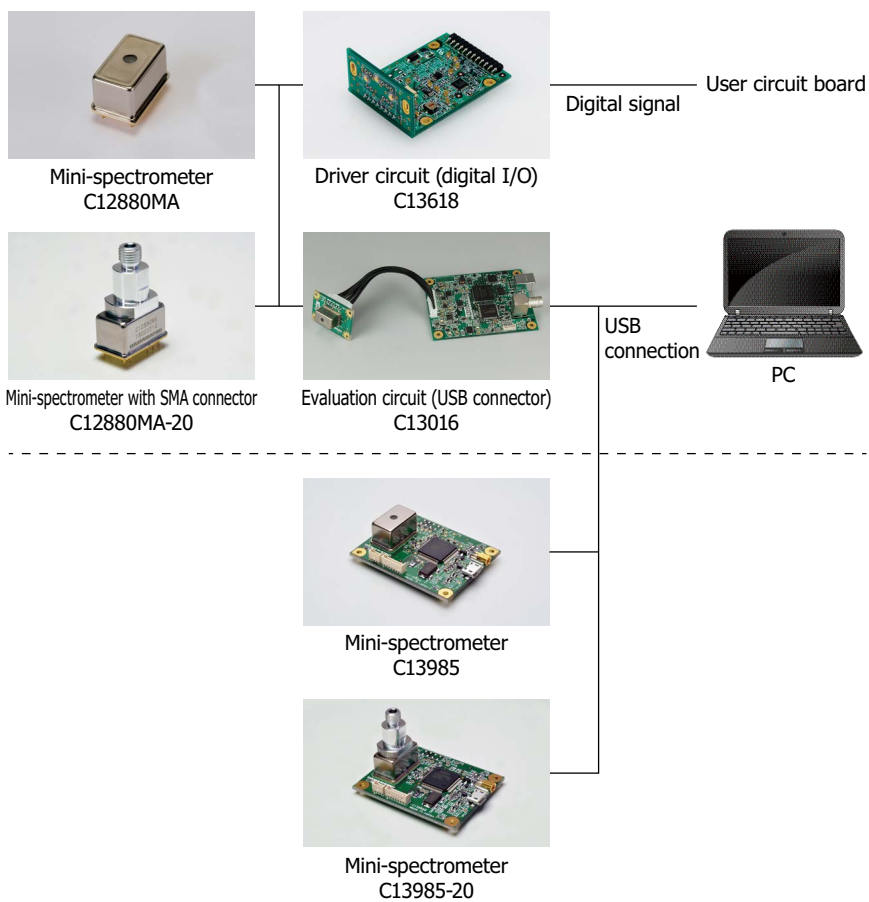

KACCC0836ED

Mini-spectrometer with SMA connector C12880MA-20

The C12880MA-20 is a product in which an SMA connector is attached to the C12880MA. It has an optical system inside the connector that can be connected with an optical fiber (single core, NA=0.22) with an SMA connector. The specifications of the C12880MA-20 is the same as those of the C12880MA except the connector section.

Dimensional outline (unit: mm)

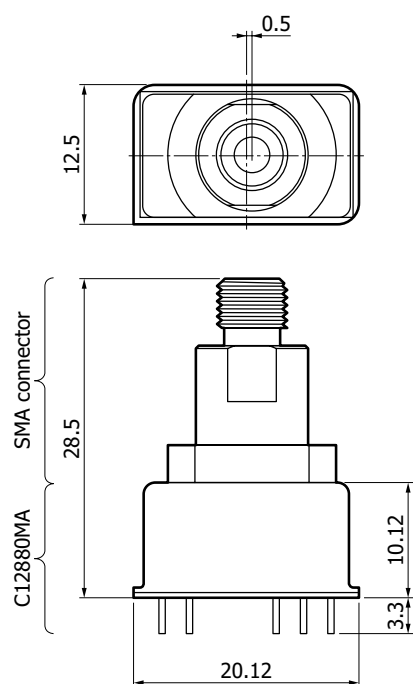

Tolerance unless
otherwise noted: ± 0.2

KACCA0381EB



Options

Product name	Type no.	Core diameter (μm)	Specification
Fiber for UV/visible range (resistance to UV)	A15362-01	600	NA=0.22, length=1.5 m With SMA905D connector on each end
	A15362-05	400	

Driver circuit for mini-spectrometer (micro series) C13618

The C13618 is a driver circuit that the C12880MA or C12880MA-20 can be mounted on. It has an A/D converter that can be used to obtain digital data (16-bit) by applying an external power supply and drive signal. Using this driver circuit with the user's circuit board having LVDS level and 3.3 V level I/O ports eliminates the need for designing analog circuits and video output conversion circuits.



Structure

Parameter	Specification	Unit
Applicable micro-spectrometers (sold separately)	C12880MA, C12880MA-20	-
A/D converter	AD7961 by Analog Devices	-
I/O terminal	Connector 801-87-012-20-002101 by PRECI-DIP	-
Number of I/O terminals	12	-
Dimensions	55 × 40 × 21.6	mm
Weight	14.3	g

Absolute maximum ratings

Parameter	Symbol	Condition	Value	Unit
Operating temperature	Topr	No dew condensation*13	+5 to +40	°C
Storage temperature	Tstg	No dew condensation*13	-20 to +70	°C

*13: When there is a temperature difference between a product and the surrounding area in high humidity environment, dew condensation may occur on the product surface. Dew condensation on the product may cause deterioration in characteristics and reliability.

Note: Exceeding the absolute maximum ratings even momentarily may cause a drop in product quality. Always be sure to use the product within the absolute maximum ratings.

Electrical characteristics (Ta=25 °C, Vs=SENSOR_ST=SENSOR_CLK=3.3 V)

Parameter	Symbol	Min.	Typ.	Max.	Unit
Sensor clock frequency	SENSOR_CLK	0.2	-	5	MHz
A/D converter clock frequency	AD_CLK	-	250	300	MHz
Current consumption	Ic	-	150	200	mA

Recommended operating conditions (Ta=25 °C)

Parameter	Symbol	Min.	Typ.	Max.	Unit
Power supply	Vs	3.15	3.3	3.45	V
Sensor clock input signal	High level	3.15	3.3	3.45	V
	Low level	0	-	0.3	
Sensor start input signal	High level	3.15	3.3	3.45	V
	Low level	0	-	0.3	
A/D converter output signal*14	Input voltage range	0.8	-	1.575	V
	Differential input voltage	0.1	-	0.65	

*14: AD_CLK+ and AD_CLK- are a pair of LVDS signals.

Dimensional outline (unit: mm)

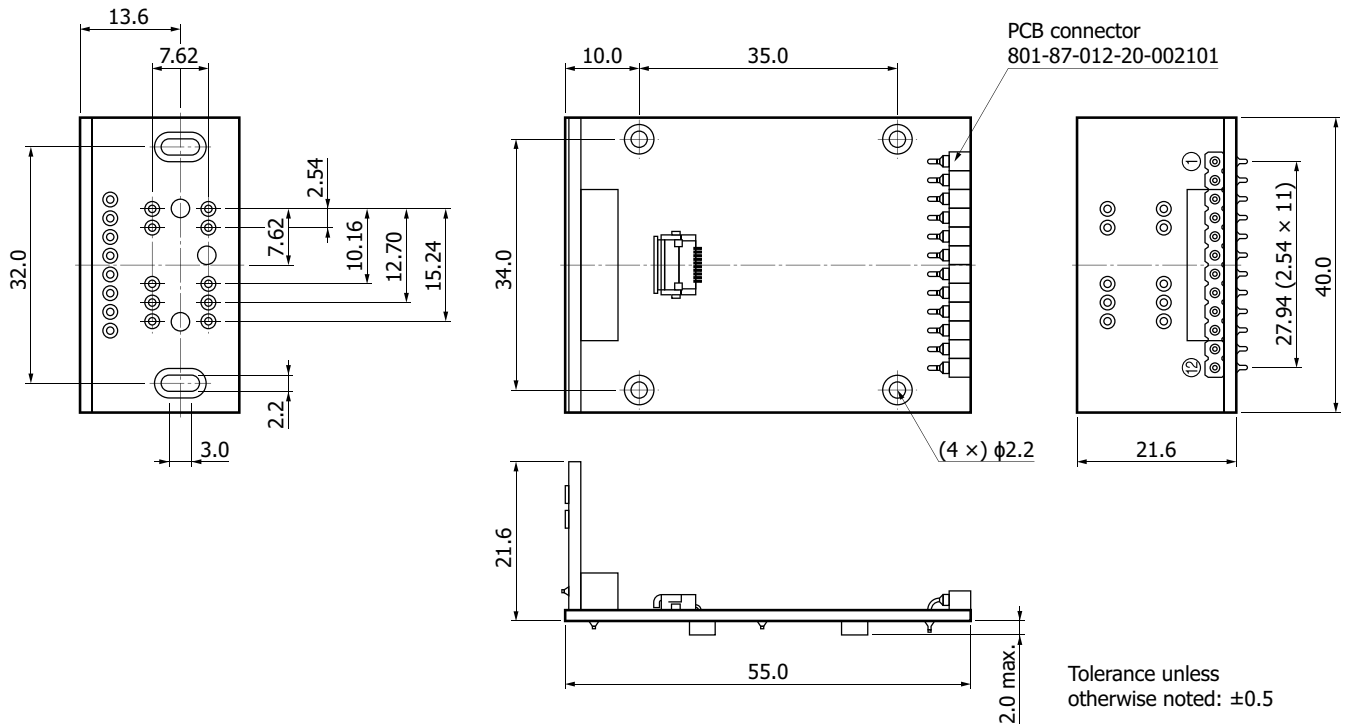

KACCA0387EA

Pin connections

Pin no.	Symbol	Input/Output	Function
1	Vs	Input	Supply voltage
2	NC	-	-
3	SENSOR_CLK	Input	Clock pulse for C12880MA and C12880MA-20
4	SENSOR_ST	Input	Start pulse for C12880MA and C12880MA-20
5	SENSOR_TRG	Output	Trigger pulse for C12880MA and C12880MA-20
6	AD_CLK+	Input	Clock pulse for A/D converter
7	AD_CLK-		
8	AD_DCO+	Output	Buffered clock pulse of A/D converter
9	AD_DCO-		
10	AD_D+	Output	Data of A/D converter
11	AD_D-		
12	GND	-	Ground

Mini-spectrometer (micro series) evaluation circuit C13016 (sold separately)

The C13016 is a circuit board designed to simply evaluate the characteristics of the mini-spectrometer C12880MA. The characteristics of the C12880MA can be evaluated using the evaluation software by connecting the C12880MA to a PC with a USB cable A9160 (AB type, sold separately)*15.

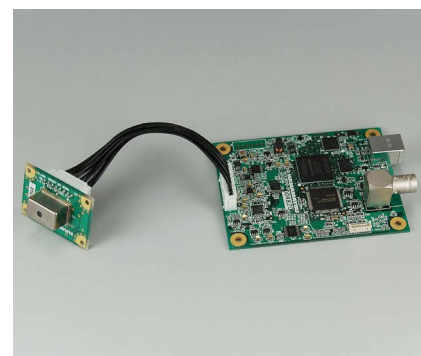

Features

- Initial evaluation circuit for mini-spectrometer C12880MA
- Wavelength conversion factors of the mini-spectrometer can be input from a PC.*16
- High A/D resolution (16-bit)
- USB powered

*15: Compatible OS:

Microsoft Windows 8.1 Pro (32-bit, 64-bit), Microsoft Windows 10 (32-bit, 64-bit)

*16: Typical wavelength conversion factors are entered at the time of shipment of the C13016. To measure a spectrum with higher wavelength accuracy, it is necessary to input the wavelength conversion factors listed in the final inspection sheet that comes with each mini-spectrometer.

Note: Microsoft and Windows are registered trademarks of Microsoft Corporation in the United States and/or other countries.

Electrical characteristics

Parameter	Specification	Unit
Interface	USB 2.0	-
A/D conversion	16	bit
Clock pulse frequency	5	MHz
Video rate	5	MHz
Integration time	11 to 1000000	μs

Structure

Parameter	Specification	Unit
Applicable spectrometer	C12880MA	-
Dimensions	Control board	90 × 70
	Sensor board	30 × 44

Absolute maximum ratings

Parameter	Condition	Value	Unit
Operating temperature	No dew condensation*17	+5 to +40	°C
Storage temperature	No dew condensation*17	-20 to +70	°C

*17: When there is a temperature difference between a product and the surrounding area in high humidity environment, dew condensation may occur on the product surface. Dew condensation on the product may cause deterioration in characteristics and reliability.

Note: Exceeding the absolute maximum ratings even momentarily may cause a drop in product quality. Always be sure to use the product within the absolute maximum ratings.

Connection example

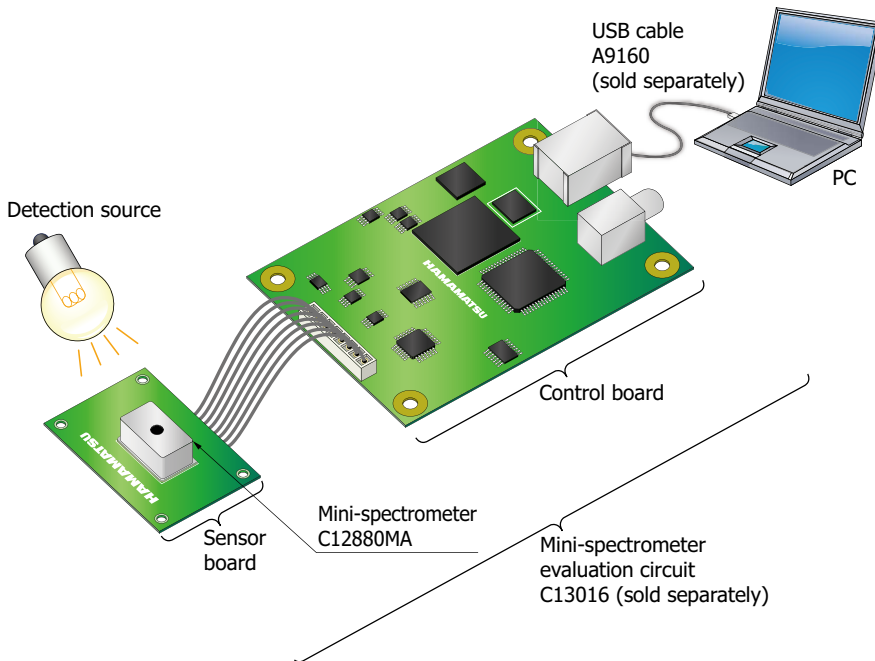

KACCCD800EB

Evaluation software display example

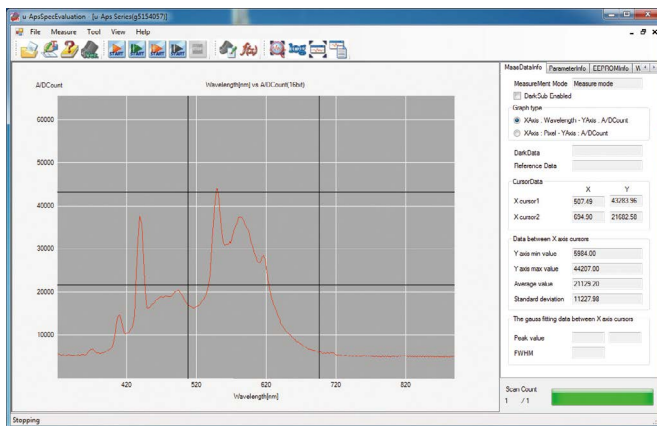

Mini-spectrometer evaluation circuit C13985 series (sold separately)

The C13985 series are USB connection type modules with mini-spectrometer (C12880MA or C12880MA-20) mounted. Spectroscopic measurement using evaluation software is possible when connected to a PC using a Micro USB cable (AB type)*18.

Features

- Modules with mini-spectrometer (C12880MA, C12880MA-20) mounted.
- Mini-spectrometer wavelength conversion factor inputted
- Operated only with USB power supply



C13985



C13985-20

*18: Compatible OS:

Microsoft Windows 8.1 Pro (32-bit, 64-bit)

Microsoft Windows 10 (32-bit, 64-bit)

Note: Microsoft and Windows are registered trademarks of Microsoft Corporation in the United States and/or other countries.

Electrical characteristics

Parameter	Specification	Unit
Interface	USB 2.0	-
A/D conversion	12	bit
Clock pulse frequency	200	kHz
Video rate	200	kHz
Integration time	270 to 1000000	μs

Structure

Parameter	C13985	C13985-20	Unit
Applicable spectrometer	C12880MA	C12880MA-20	-
Dimensions	40 × 50 × 14.7	40 × 50 × 32.3	mm

Absolute maximum ratings

Parameter	Condition	Value	Unit
Operating temperature	No dew condensation*19	+5 to +40	°C
Storage temperature	No dew condensation*19	-20 to +70	°C

*19: When there is a temperature difference between a product and the surrounding area in high humidity environment, dew condensation may occur on the product surface. Dew condensation on the product may cause deterioration in characteristics and reliability.

Note: Exceeding the absolute maximum ratings even momentarily may cause a drop in product quality. Always be sure to use the product within the absolute maximum ratings.

Related information

www.hamamatsu.com/sp/ssd/doc_en.html

- Precautions
- Disclaimer

- Technical information
- Mini-spectrometers

Information described in this material is current as of December 2022.

Product specifications are subject to change without prior notice due to improvements or other reasons. This document has been carefully prepared and the information contained is believed to be accurate. In rare cases, however, there may be inaccuracies such as text errors. Before using these products, always contact us for the delivery specification sheet to check the latest specifications.

The product warranty is valid for one year after delivery and is limited to product repair or replacement for defects discovered and reported to us within that one year period. However, even if within the warranty period we accept absolutely no liability for any loss caused by natural disasters or improper product use. Copying or reprinting the contents described in this material in whole or in part is prohibited without our prior permission.

HAMAMATSU

www.hamamatsu.com

HAMAMATSU PHOTONICS K.K., Solid State Division

1126-1 Ichino-cho, Higashi-ku, Hamamatsu City, 435-8558 Japan, Telephone: (81)53-434-3311, Fax: (81)53-434-5184

U.S.A.: HAMAMATSU CORPORATION: 360 Foothill Road, Bridgewater, NJ 08807, U.S.A., Telephone: (1)908-231-0960, Fax: (1)908-231-1218

Germany: HAMAMATSU PHOTONICS DEUTSCHLAND GMBH: Arzbergerstr. 10, 82211 Herrsching am Ammersee, Germany, Telephone: (49)8152-375-0, Fax: (49)8152-265-8 E-mail: info@hamamatsu.de

France: HAMAMATSU PHOTONICS FRANCE S.A.R.L.: 19 Rue du Saule Trapu, Parc du Moulin de Massy, 91882 Massy Cedex, France, Telephone: (33)1 69 53 71 00, Fax: (33)1 69 53 71 10 E-mail: infos@hamamatsu.fr

United Kingdom: HAMAMATSU PHOTONICS UK LIMITED: 2 Howard Court, 10 Tewin Road, Welwyn Garden City, Hertfordshire, AL7 1BW, UK, Telephone: (44)1707-294888, Fax: (44)1707-325777 E-mail: info@hamamatsu.co.uk

North Europe: HAMAMATSU PHOTONICS NORDEN AB: Torshamnsgatan 35, 16440 Kista, Sweden, Telephone: (46)8-509-031-00, Fax: (46)8-509-031-01 E-mail: info@hamamatsu.se

Italy: HAMAMATSU PHOTONICS ITALIA S.R.L.: Strada della Moia, 1 int. 6 20044 Arese (Milano), Italy, Telephone: (39)02-93 58 17 33, Fax: (39)02-93 58 17 41 E-mail: info@hamamatsu.it

China: HAMAMATSU PHOTONICS (CHINA) CO., LTD.: 1201, Tower B, Jiaming Center, 27 Dongsanhuan Beilu, Chaoyang District, 100020 Beijing, P.R. China, Telephone: (86)10-6586-6006, Fax: (86)10-6586-2866 E-mail: hpc@hamamatsu.com.cn

Taiwan: HAMAMATSU PHOTONICS TAIWAN CO., LTD.: 8F-3, No.158, Section 2, Gongdao 5th Road, East District, Hsinchu, 300, Taiwan R.O.C. Telephone: (886)3-659-0080, Fax: (886)3-659-0081 E-mail: info@hamamatsu.com.tw