

PureFlow WS1

Traffic Shaper NF7500 series WebGUI Operation Manual

Third Edition

- For safe and appropriate use of the equipment, please read this manual before using the equipment.
- Additional safety and warning information is provided within the Operation Manual (NF7500-W011E). Please also refer to this document before using the equipment.
- Keep the manual with the equipment.

ANRITSU CORPORATION

Safety Symbols

To prevent the risk of personal injury or loss related to equipment malfunction, Anritsu Corporation uses the following safety symbols to indicate safety-related information. Ensure that you clearly understand the meanings of the symbols BEFORE using the equipment.

Some or all of the following symbols may be used on all Anritsu Corporation equipment. In addition, there may be other labels attached to products that are not shown in the diagrams in this manual.

Symbols used in this manual

 **DANGER** This indicates a very dangerous procedure that could result in serious injury or death if not performed properly.

 **WARNING** This indicates a hazardous procedure that could result in serious injury or death if not performed properly.

 **CAUTION** This indicates a hazardous procedure or danger that could result in light-to-severe injury, or loss related to equipment malfunction, if proper precautions are not taken.

Safety Symbols Used on Equipment and in Manual

The following safety symbols are used inside or on the equipment near operation locations to provide information about safety items and operation precautions. Ensure that you clearly understand the meanings of the symbols and take the necessary precautions BEFORE using the equipment.



This indicates a prohibited operation. The prohibited operation is indicated symbolically in or near the barred circle.



This indicates an obligatory safety precaution. The obligatory operation is indicated symbolically in or near the circle.



This indicates a warning or caution. The contents are indicated symbolically in or near the triangle.



This indicates a note. The contents are described in the box.

PureFlow WS1
Traffic Shaper NF7500 series
WebGUI Operation Manual

31 May 2017 (First Edition)
15 June 2020 (Third Edition)

Copyright © 2017-2020, ANRITSU CORPORATION

All rights reserved. No part of this manual may be reproduced without the prior written permission of the publisher.

The contents of this manual may be changed without prior notice.

Printed in Japan

Anritsu Corporation Contact

For information on this equipment, contact an Anritsu Corporation Service and Sales office. Contact information can be found on the safety manual.

Maintenance Contract

Anritsu Corporation can provide a range of optional services under a maintenance contract. For details, contact your dealer.

Notes On Export Management

This product and its manuals may require an Export License/Approval by the Government of the product's country of origin for re-export from your country.

Before re-exporting the product or manuals, please contact us to confirm whether they are export-controlled items or not.

When you dispose of export-controlled items, the products/manuals need to be broken/shredded so as not to be unlawfully used for military purpose.

Trademark/Registered Trademark

Windows, Internet Explorer, and Microsoft Edge are trademarks or registered trademarks of Microsoft Corporation in the United States and/or other countries.

Firefox is a trademark or registered trademark of Mozilla Foundation in the United States and/or other countries.

About This Manual

This manual describes in detail the operation method of WebGUI used in the PureFlow WS1 Traffic Shaper (hereafter referred to as “this device”).

The applicable models of this equipment are described below.

- NF7501A

The manual of this device consists of the following four manuals. This document is <4>.

<1> Operation Manual (NF7500–W011E)

Describes in detail the installation and handling of this device.

<2> Command Reference (NF7500–W012E)

Describes in detail the commands used in this device.

<3> Configuration Guide (NF7500–W013E)

Describes the basic features of this device and provides specific examples of the settings required to build a network using these features.

<4> WebGUI Operation Manual (NF7500–W014E)

Describes the operation for setting and display of this device using a Web browser.

If the following documents related to this device or other documents related to the features of this device are issued, be sure to read them:

Release notes

(For details of the issuance of release notes, contact your dealer.)

Table of Contents

About This Manual.....	I
Chapter 1 Overview	1-1
Chapter 2 Operating Environment.....	2-1
Chapter 3 Operation Method.....	3-1
3.1 Marks Used in Text	3-2
3.2 Notes for Settings	3-3
3.3 How to Log In / Log Out.....	3-4
3.4 Screen Configuration	3-7
3.5 Setting Flow	3-8
3.6 How to Set Channel.....	3-9
3.7 How to Set IP Address of Channel	3-12
3.8 How to Configure Scenario.....	3-14
3.9 Application Acceleration Settings	3-18
3.10 How to Configure Filter	3-22
3.11 How to Set Rule List	3-26
3.12 How to Perform Settings Related to Time	3-30
3.13 Setting Flow Identification Mode.....	3-37
3.14 How to Display Traffic Graph of Scenario.....	3-39
3.15 How to Display Traffic Graph of Network Port.....	3-43
3.16 How to Display WAN-accel Sessions Graph	3-46
3.17 How to Check and Save Configuration.....	3-52
3.18 How to Check System Log	3-56
3.19 How to Check Module Information.....	3-58
3.20 How to Perform Maintenance Operations.....	3-59

1
2
3

(Blank page)

This chapter describes overview of WebGUI.

This device is equipped with WebGUI (Graphical User Interface). WebGUI is an application to perform settings, display and maintenance of this device by using the Web browser of the network-connected terminal.

The WebGUI system sketch drawing is shown below:

WebGUI is connected from the system interface. For the system interface setting method, refer to "PureFlow WS1 Traffic Shaper NF7500 Series Configuration Guide". Do not exceed four sessions including WebAPI when using WebGUI.

- (1) Connection via the Ethernet port

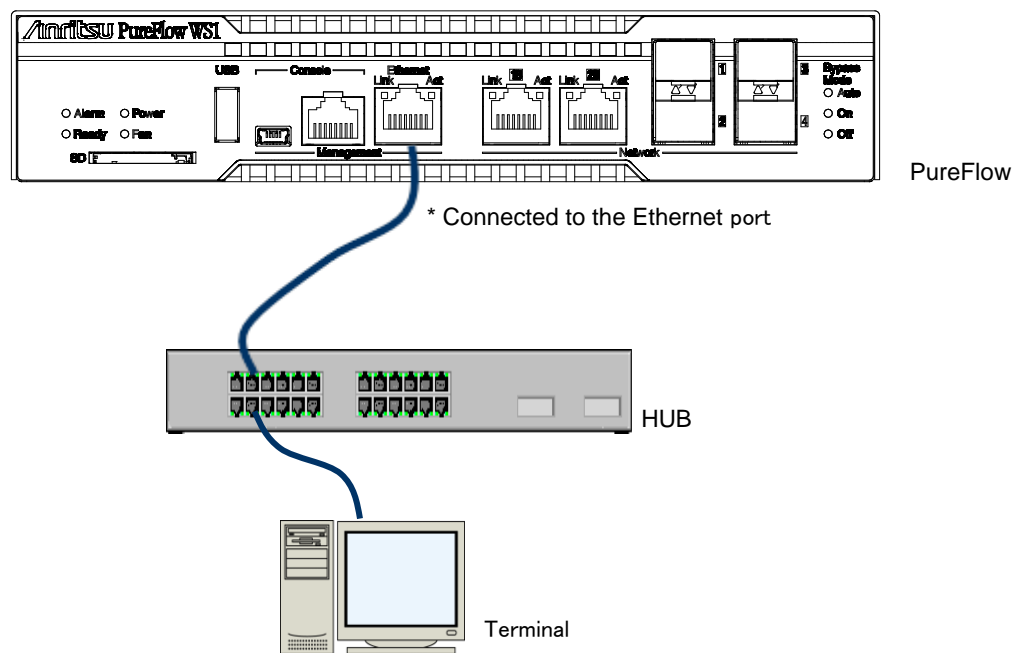

Figure 1.1 WebGUI system sketch drawing (Ethernet port)

(2) Connection via the Network port

This device cannot be managed remotely in the bypass connection state enabled by the network bypass function. To manage this device remotely in the bypass connection state, connect this device via the Ethernet port.

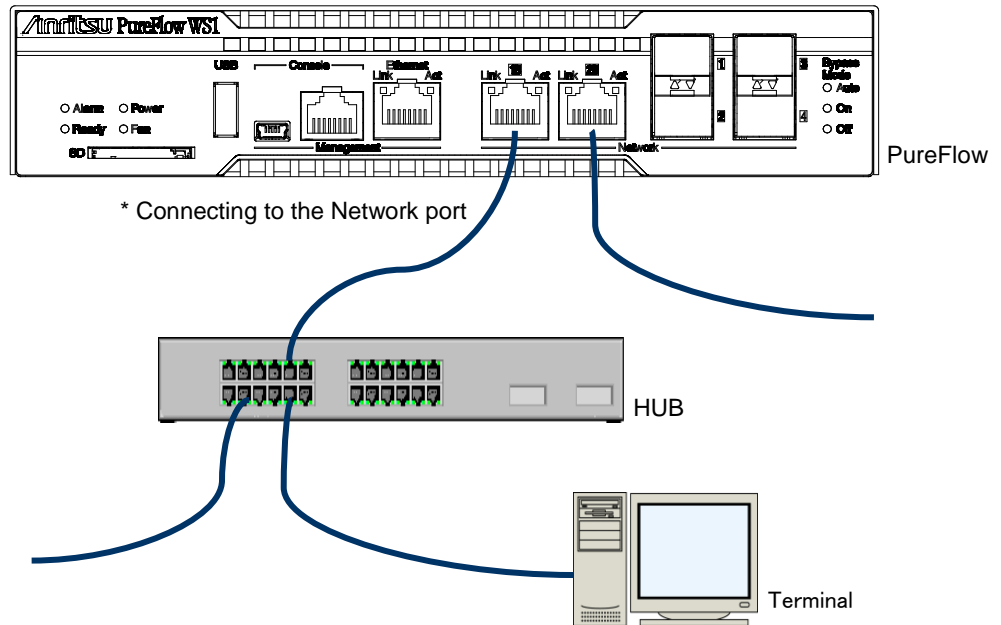

Figure 1.2 WebGUI system sketch drawing (Network port)

WebGUI enables the partial settings, display and maintenance of this device.

The items that can be set, displayed and maintained by WebGUI are shown below:

- Items related to network

WebGUI enables the following settings related to the traffic control.

- Channel setting
- Channel IP address setting
- Scenario configuration
- Application acceleration configuration
- Filter configuration
- Rule list setting
- Flow identification mode setting

- Items related to management

WebGUI enables the following settings related to the device built-in time.

- Time zone setting
- Daylight-saving time setting
- SNTP setting
- Manual time setting

- Items related to display

WebGUI enables the following settings.

- Scenario traffic graph
- Network port traffic graph
- WAN accel sessions graph
- Configuration
- Syslog
- Module information

- Items related to maintenance

WebGUI enables the following maintenance.

- Uploading software
- Restarting the device

(Blank page)

Chapter 2 Operating Environment

This chapter describes the operating environment of WebGUI.

Use WebGUI under the recommended operating environment described below:

Using under environments other than the recommended operating environment cannot ensure the WebGUI is operated normally. Additionally, use the terminal that is not affected by the virus.

- OS
 - Windows® 7
 - Windows® 8.1
 - Windows® 10

- Web browser
 - Internet Explorer® 9.0
 - Internet Explorer® 10.0
 - Internet Explorer® 11.0
 - Microsoft Edge™ 20 or later
 - Firefox® 4

- CPU
 - 2.6 GHz or more

- Memory
 - 4 GB or more

(Blank page)

Chapter 3 Operation Method

This chapter describes how to operate WebGUI.

3.1	Marks Used in Text.....	3-2
3.2	Notes for Settings	3-3
3.3	How to Log In / Log Out.....	3-4
3.4	Screen Configuration	3-7
3.5	Setting Flow	3-8
3.6	How to Set Channel.....	3-9
3.7	How to Set IP Address of Channel	3-12
3.8	How to Configure Scenario.....	3-14
3.9	Application Acceleration Settings	3-18
3.10	How to Configure Filter	3-22
3.11	How to Set Rule List	3-26
	3.11.1 How to set rule list group	3-26
	3.11.2 How to set rule list entry	3-28
3.12	How to Perform Settings Related to Time	3-30
	3.12.1 How to set time zone	3-31
	3.12.2 How to set daylight-saving time.....	3-32
	3.12.3 How to set SNTP	3-33
	3.12.4 How to set time manually	3-35
3.13	Setting Flow Identification Mode.....	3-37
3.14	How to Display Traffic Graph of Scenario	3-39
3.15	How to Display Traffic Graph of Network Port.....	3-43
3.16	How to Display WAN-accel Sessions Graph	3-46
3.17	How to Check and Save Configuration.....	3-52
	3.17.1 How to check configuration	3-52
	3.17.2 How to save configuration	3-55
3.18	How to Check System Log	3-56
3.19	How to Check Module Information	3-58
3.20	How to Perform Maintenance Operations	3-59
	3.20.1 How to upload software	3-60
	3.20.2 How to reboot the device.....	3-63

3.1 Marks Used in Text

The following marks are used in this chapter:

- " " mark: Indicates the name displayed on the Web browser screen.
- [] mark: Indicates the point to be clicked (selected) on the Web browser screen.
- [] mark: Indicates the name of the reference destination.
- " " mark: Indicates a proper name other than those described above.
- * mark: Indicates the items to be noted.

Numbers, for example, <1>:

Used when a procedure for the operation on the Web browser screen is shown related to the operation described in this chapter.

3.2 Notes for Settings

After settings, be sure to save the setting contents by referring to “3.17.2 How to save configuration”.

The setting detail is reflected without saving it. However, the setting is deleted when restarting this device.

3.3 How to Log In / Log Out

To use WebGUI, the system interface (IP address) of this device must be configured.

For details of how to set the system interface, refer to [PureFlow WS1 Traffic Shaper NF7500 series Command Reference].

After the completion of system interface setting, start up the Web browser, and specify the IP address set in the system interface.

- * The default value of the system interface is 192.168.1.1.
When the IP address is 192.168.1.1, specify as described below.
`http://192.168.1.1`

When the connection to this device is successfully established, the login screen is displayed as shown below.

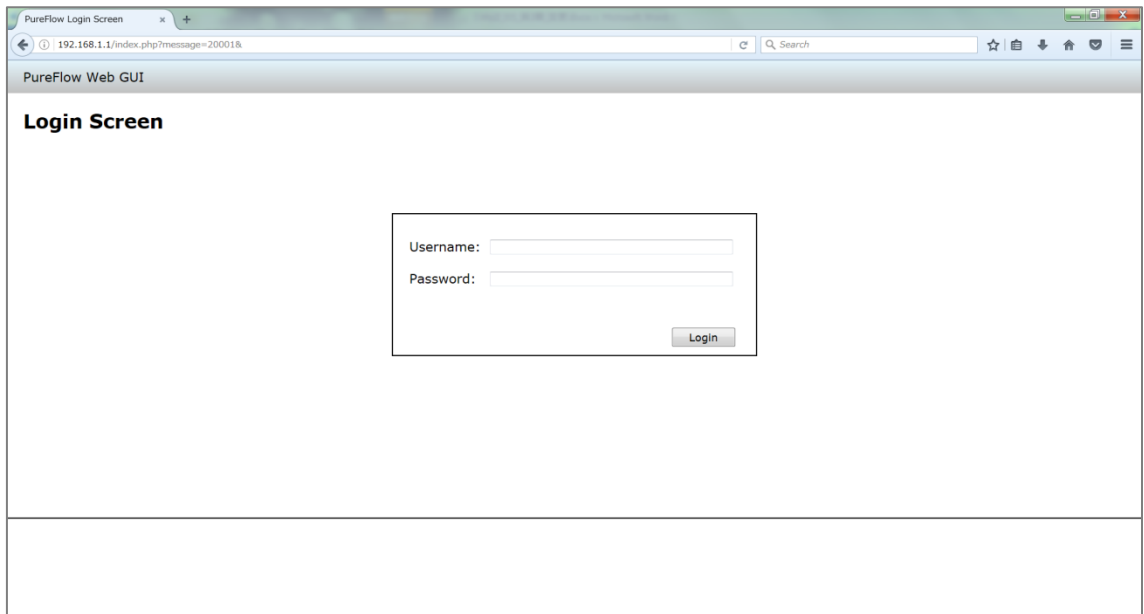

Enter "admin" in the "Username" column. Enter the adminpassword which was set for this device in the "Password" column. If the password was not set, do not fill the "Password" column. Click the [Login] button for login.

* For details of how to set the password, refer to [PureFlow WS1 Traffic Shaper NF7500 series Command Reference]. Be sure to set the adminpassword for security reasons.

For login by the RADIUS authentication server, enter the RADIUS server user name in the "UserName" column. Enter the RADIUS server password in the "Password" column, and click the [Login] button for login.

When Top Page is displayed as shown below, login has been completed.

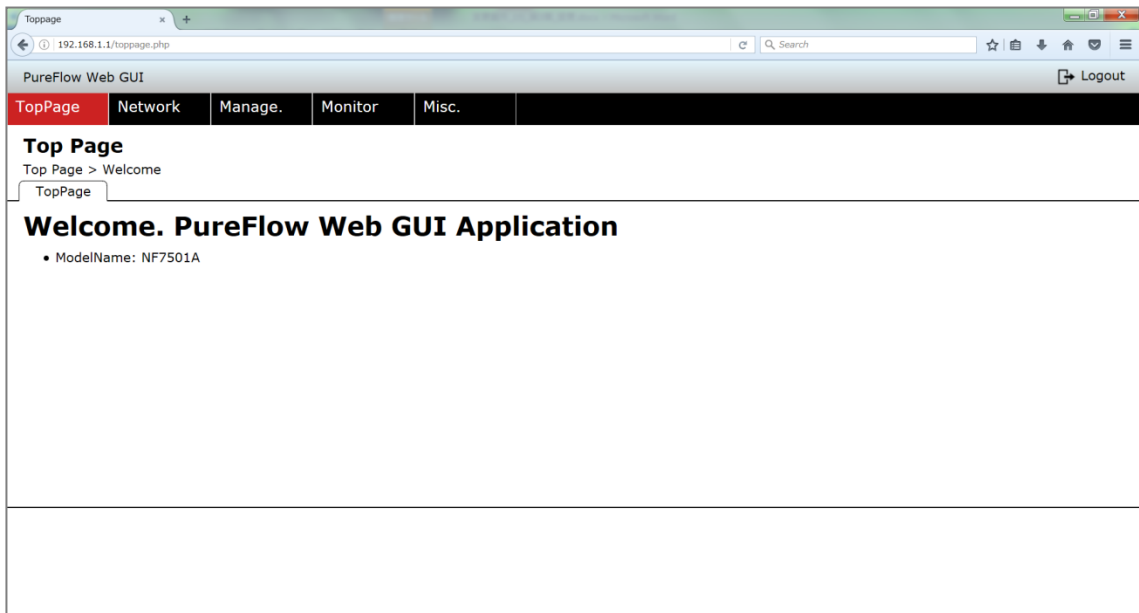

Note:

When a channel, a scenario and a filter register the biggest number with this device, it takes time for operation of login of WebGUI, setting and display.

When logging in to this device in WebGUI, please set each registration number of the channel, the scenario and the filter to less than 3000.

For logout, click the [Logout] button at upper right of the screen.
If this screen is not operated for 5 minutes, it automatically logs out.
Time taken until the automatic logout is 5 minutes.

* This time cannot be changed.

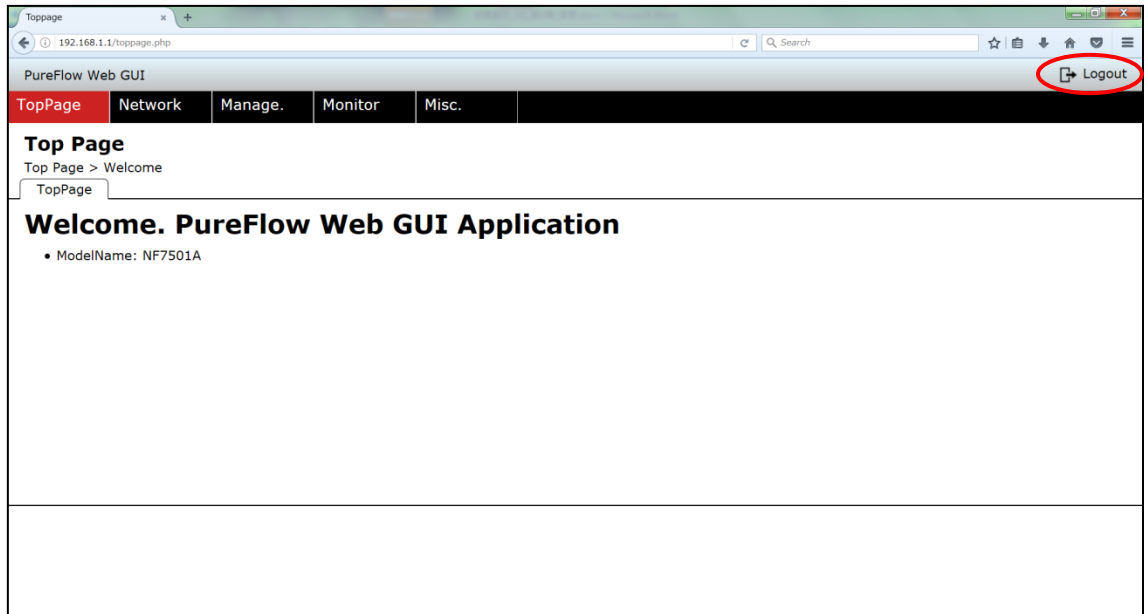

3.4 Screen Configuration

Selecting the tab on the WebGUI screen switches the screen.

The screens corresponding to the tabs selected are configured as shown below.

TopPage	.. This screen is the top page of WebGUI. This screen enables you to check the model name and model number of this device.
Network	<ul style="list-style-type: none"> — General This screen is used for the general settings related to the network. — Channel..... This screen is used for setting channel and IP address of the channel. — Scenario..... This screen is used for the scenario setting. — Filter / Rulelist..... This screen is used for setting the filter and rule list. — Application This screen is used for setting the application acceleration.
Manage.	— Time This screen is used for the settings related to the time.
Monitor	<ul style="list-style-type: none"> — Scenario Traffic This screen is shows traffic graph of specified scenario. — Network Port Traffic · This screen is shows traffic graph of network port. — WAN Accel Sesions · This screen is shows sessions graph that applied the traffic acceleration.
Misc.	<ul style="list-style-type: none"> — Config This screen shows the setting information of this device and is used for saving the settings. — Syslog..... This screen shows the system log information of this device. — Maintenance..... This screen is used for the settings related to the maintenance of this device. — About..... This screen shows the module information of this device.

3.5 Setting Flow

The respective setting flows are shown below.

The setting can be performed in orders other than the order shown below. However, please note that the IP address of the channel can be set only after setting the channel and that the filter can be set only after setting the scenario.

WebGUI works with CLI (Command Line Interface) of this device. Therefore, understanding the command specifications enables you to set the WebGUI smoothly.

For details of the command specifications, refer to [PureFlow WS1 Traffic Shaper NF7500 series Command Reference].

Set WebGUI.	Related CLI command	Description
<div style="border: 1px solid black; padding: 5px; text-align: center;"> STEP 1 Set the channel. </div>	add channel delete channel show channel	Set the channel required for the bridge operation between desired 2 ports. Specify 1 port each on the LAN side and WAN side of 1 channel.
↓		
<div style="border: 1px solid black; padding: 5px; text-align: center;"> STEP 2 Set the IP address of the channel. </div>	set ip channel unset ip channel show ip channel	When using the traffic acceleration function, set the IP address for the channel set in STEP 1. This setting is not required to use the traffic shaping function only.
↓		
<div style="border: 1px solid black; padding: 5px; text-align: center;"> STEP 3 Configure the scenario. </div>	add scenario update scenario delete scenario show scenario	Set the scenario required for the traffic control.
↓		
<div style="border: 1px solid black; padding: 5px; text-align: center;"> STEP 4 Configure the filter and rule list (as required). </div>	add filter delete filter show filter add rulelist group add rulelist entry delete rulelist group delete rulelist entry show rulelist	Set the filter criteria to classify the packet. Set the filter for the scenario set in STEP 3. Additionally, create the rule list with the packet classification grouped, as required, and set the list as a filter.

3.6 How to Set Channel

Set the channel.

Place the mouse cursor on the [Network] tab at upper left of the screen.

The pull-down menu of the Network menu appears. Click the [Channel] tab.

The Channel Setting screen appears as shown below.

Channel Setting

Networking > Channel

General Channel Scenario Filter / Rulelist Application

Name	WAN	LAN	Type	VLAN ID	Inner VLAN ID	TPID	Inner TPID	MTU
ch1	1/2	1/1	Default					

Diagram showing four ports: 1/1, 1/2, 1/3, 1/4

Channel Name:

WAN:

LAN:

Default Normal

VLAN ID:

TPID:

Inner VLAN ID:

Inner TPID:

MTU:

IP Channel

ChannelName	IpAddress(Ipv4)	Netmask(Ipv4)	IpAddress(Ipv6)	PrefixLength(Ipv6)
ch1				

ChannelName:

IPv4 Set UnSet

IP Address:

NetMask:

IPv6 Set UnSet

IP Address:

PrefixLength:

<1> Enter and select the parameter in the column on the left side of the screen, and <2> click the [Add] button.

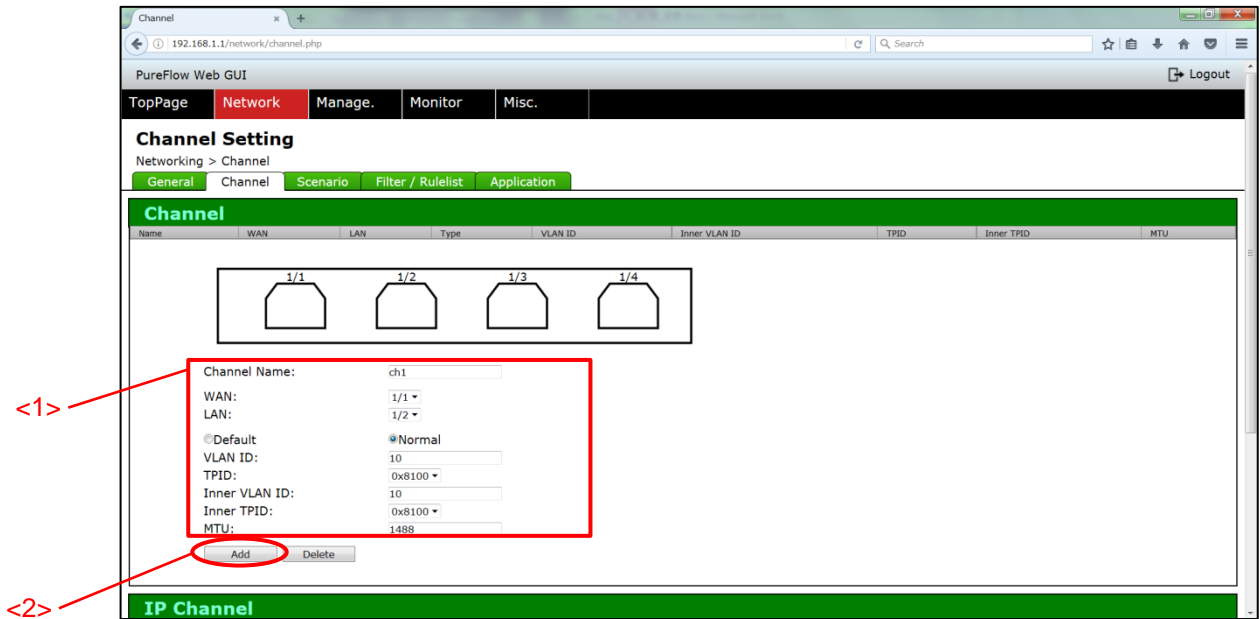

Check that the channel has been added as shown below.

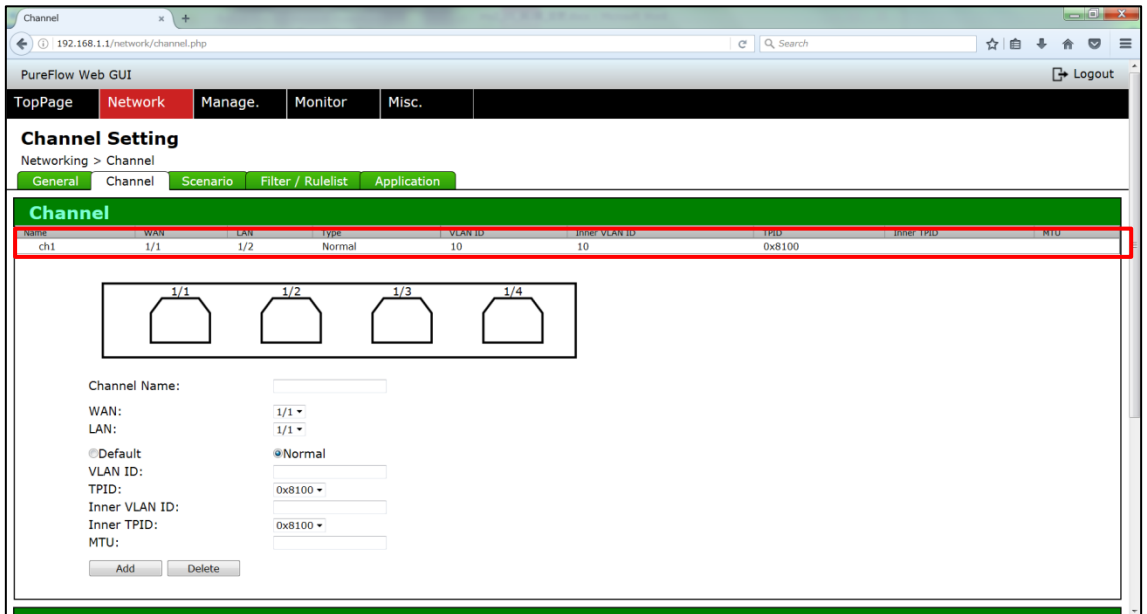

To delete the channel , <3> select the relevant channel.
<4> Click the [Delete] button to delete the channel.

The screenshot shows the 'Channel Setting' page in the PureFlow Web GUI. The page has a navigation bar with 'TopPage', 'Network', 'Manage.', 'Monitor', and 'Misc.'. Below the navigation bar, there are tabs for 'General', 'Channel', 'Scenario', 'Filter / RuleList', and 'Application'. The 'Channel' tab is selected. A table lists channels, with the first row highlighted in red and labeled '<3>'. The table has columns for Name, WAN, LAN, Type, VLAN ID, Inner VLAN ID, and MTU. Below the table, there are four port icons labeled 1/1, 1/2, 1/3, and 1/4. Below the icons, there are input fields for Channel Name, WAN, LAN, and radio buttons for Default and Normal. There are also input fields for VLAN ID, TPID, Inner VLAN ID, and MTU. At the bottom, there are 'Add' and 'Delete' buttons. The 'Delete' button is circled in red and labeled '<4>'.

Name	WAN	LAN	Type	VLAN ID	Inner VLAN ID	MTU
ch1	1/1	1/2	Normal	10	10	0x8100

Channel Name:

WAN:

LAN:

Default Normal

VLAN ID:

TPID:

Inner VLAN ID:

Inner TPID:

MTU:

3

Operation Method

3.7 How to Set IP Address of Channel

Set the IP address of the channel.

* To set the IP address of the channel, set the channel in advance.

<1> Select the relevant channel.

<2> IPv4 and IPv6 address can be set. Select radio button [set] or [unset]. Enter the IP address in the "IPAddress" column, and the net mask or prefix in the "NetMask" column respectively.

<3> Click the [Apply] button, the IP address will be set or unset.

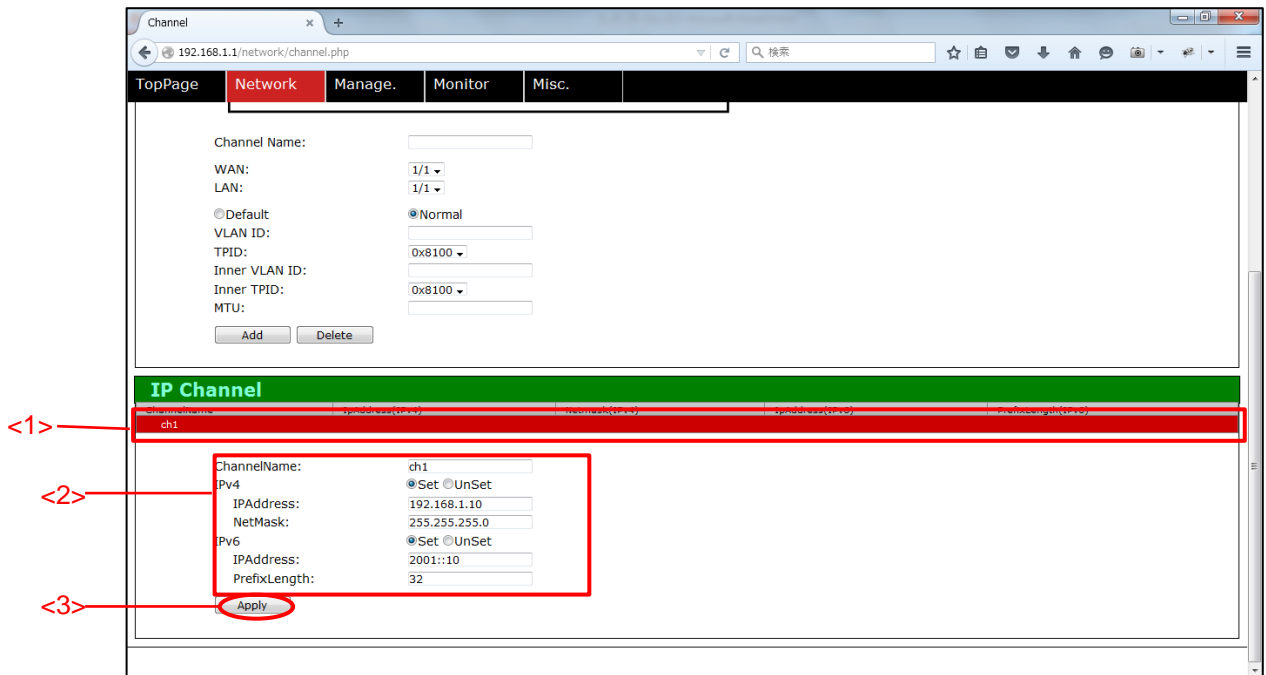

Check that IP address has been added as shown below.

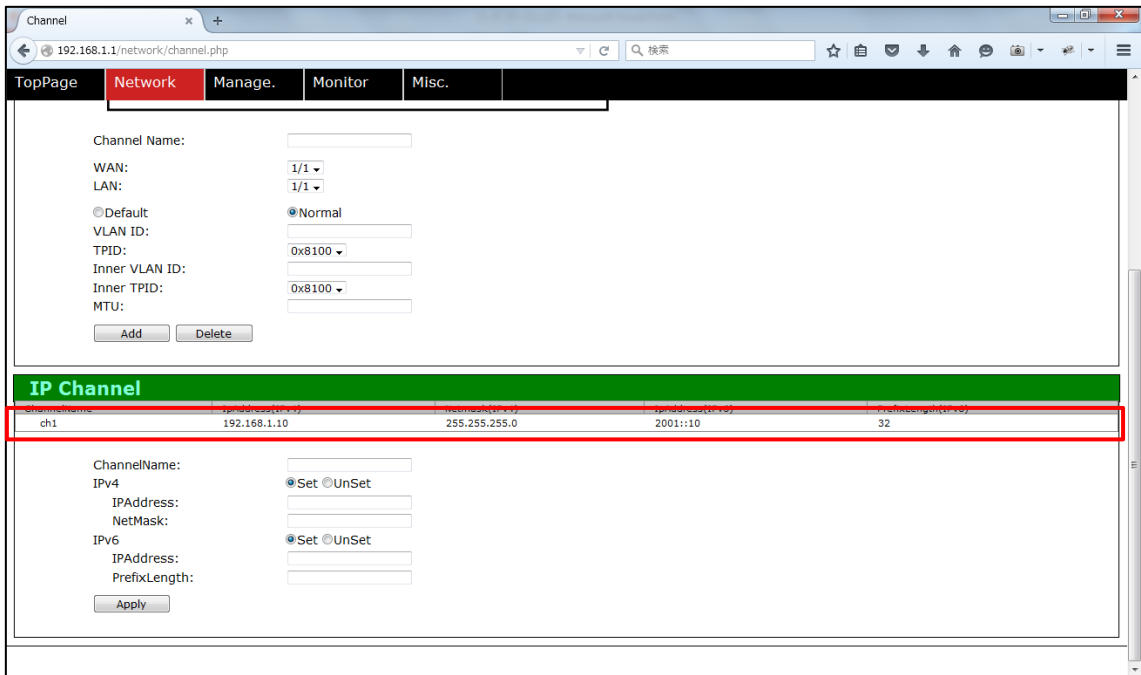

3

Operation Method

3.8 How to Configure Scenario

Configure the scenario.

- * To register the Wan Accel scenario, the TCP acceleration function license is required.

Place the mouse cursor on the [Network] tab at upper left of the screen. The pull-down menu of the Network menu appears. Click the [Scenario] tab.

The Scenario Configuration screen appears as shown below.

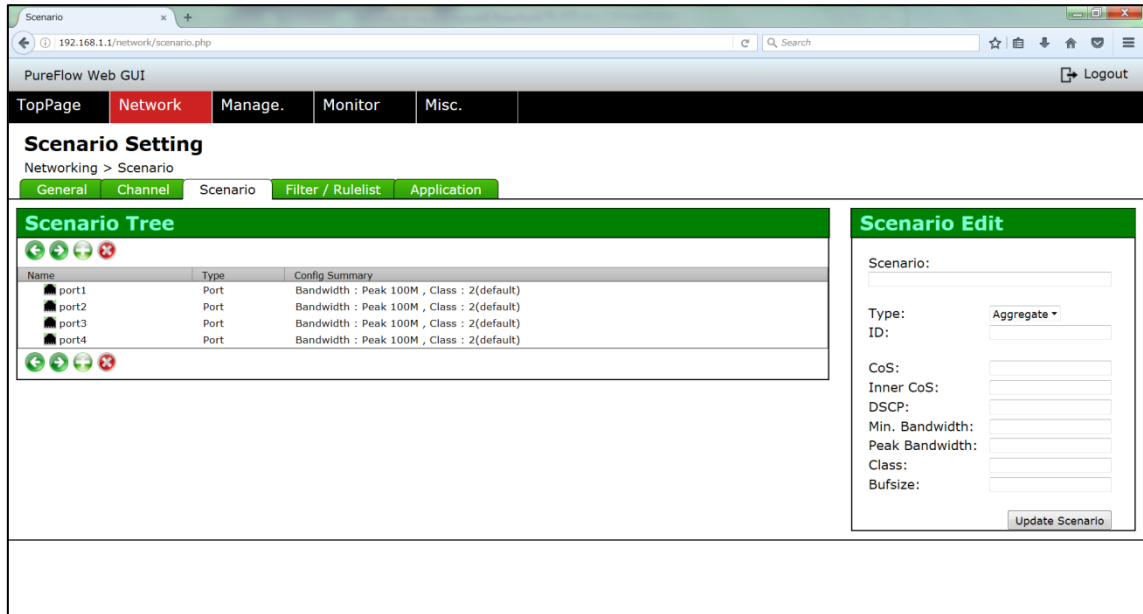

The scenario on the 1st layer is configured as the default scenario in each port. As an example, procedure for adding a scenario on the 2nd layer for port1 is described below.

<1> Select "port1" in the "Scenario Tree" window on the left side of the screen, and <2> click the [+] button in green.

<3> Enter each parameter in the "Scenario Edit" window on the right side of the screen, and <4> click the [Add Scenario] button.

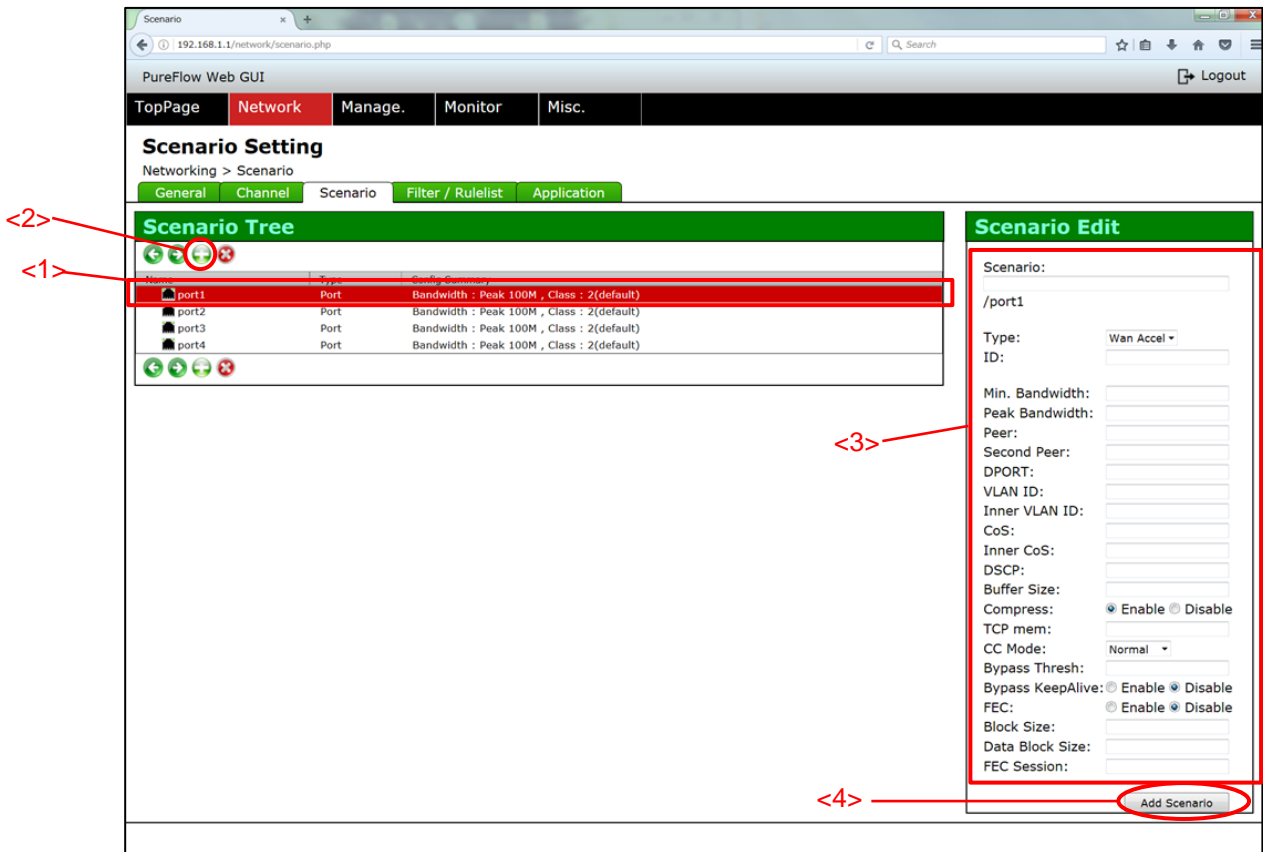

Check that the [+] button in gray appears at the scenario on the first layer in the "Scenario Tree" window as shown below. This button appears to indicate the existence of the scenarios on the lower layers.

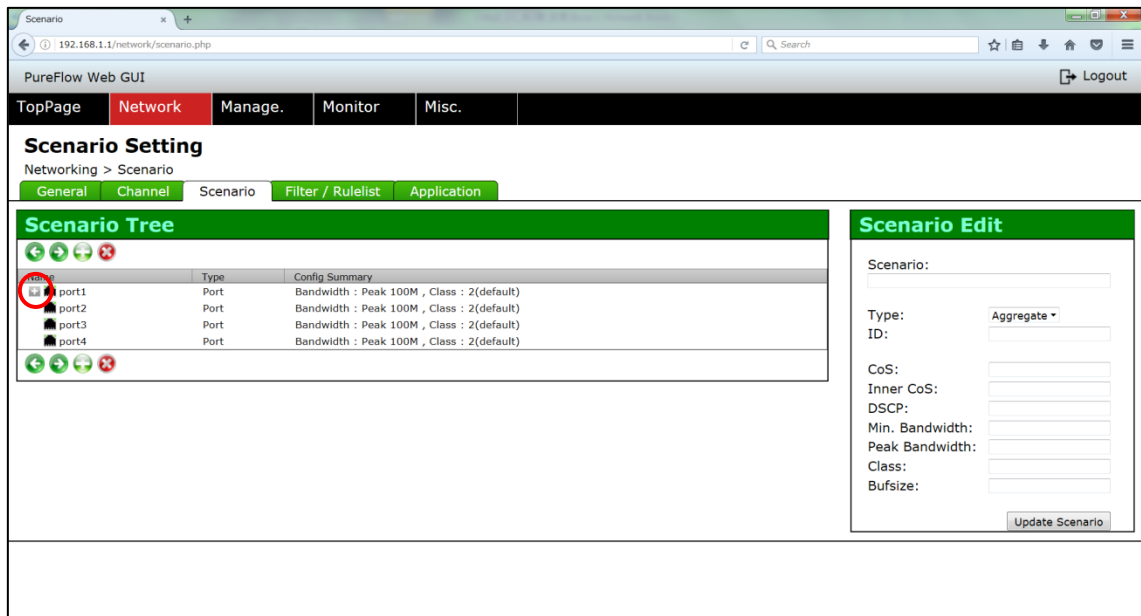

Clicking the [+] button in gray displays the scenarios on the lower layers.
 By selecting the relevant scenario, the parameter of the scenario can be checked in the "Scenario Edit" window.

To delete the scenario or change the parameter, <5> select the relevant scenario.

To delete the scenario, <6> click the [x] button in red.

After changing the relevant parameter, <7> click the [Update Scenario] button to change the scenario.

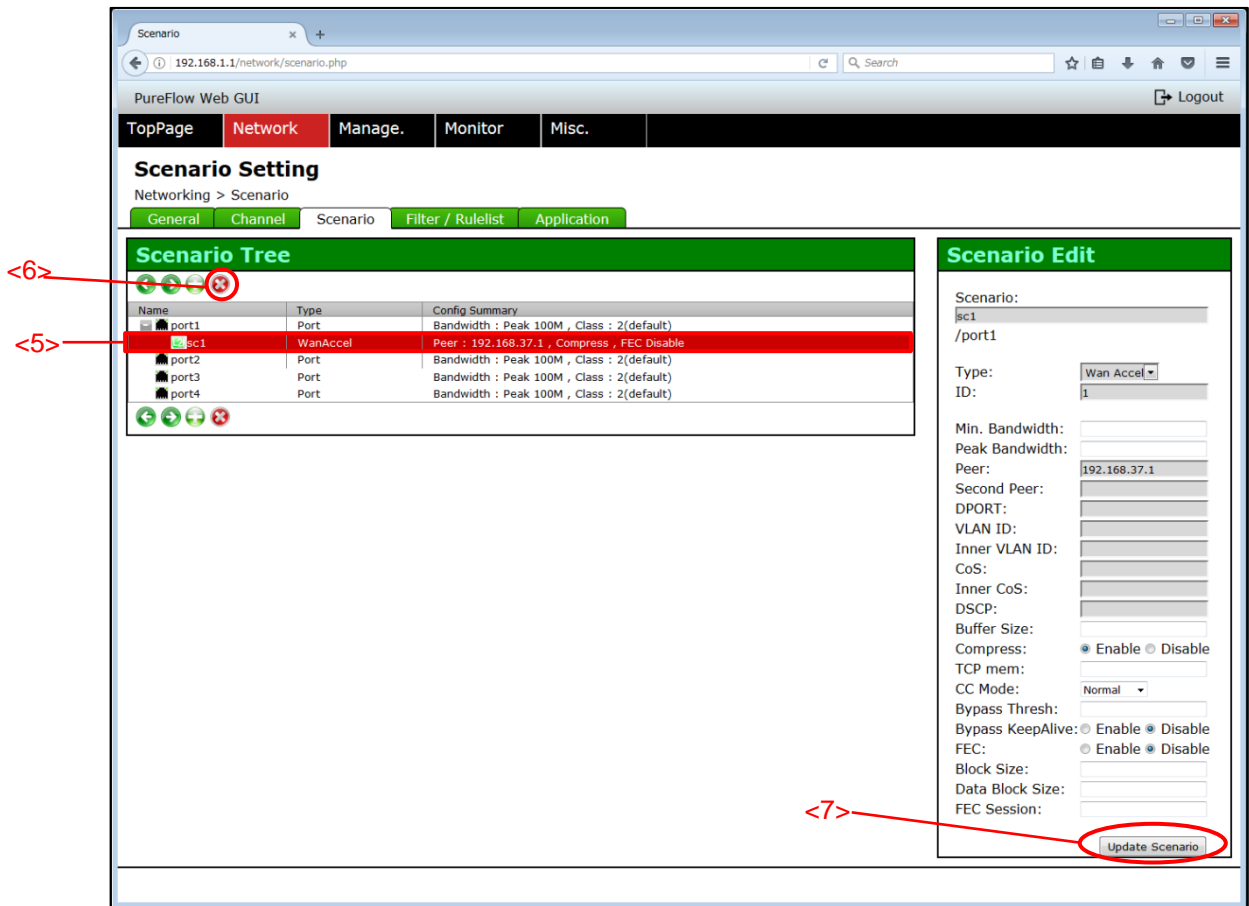

3.9 Application Acceleration Settings

Register the application acceleration.

* To register the application acceleration setting, the TCP acceleration function license is required.

In addition, configure the acceleration mode scenario prior to registration.

Place the mouse cursor on the [Network] tab at the upper left of the screen.

The pull-down menu of the Network menu appears. Click the [Application] tab.

The Application Setting screen appears as shown below.

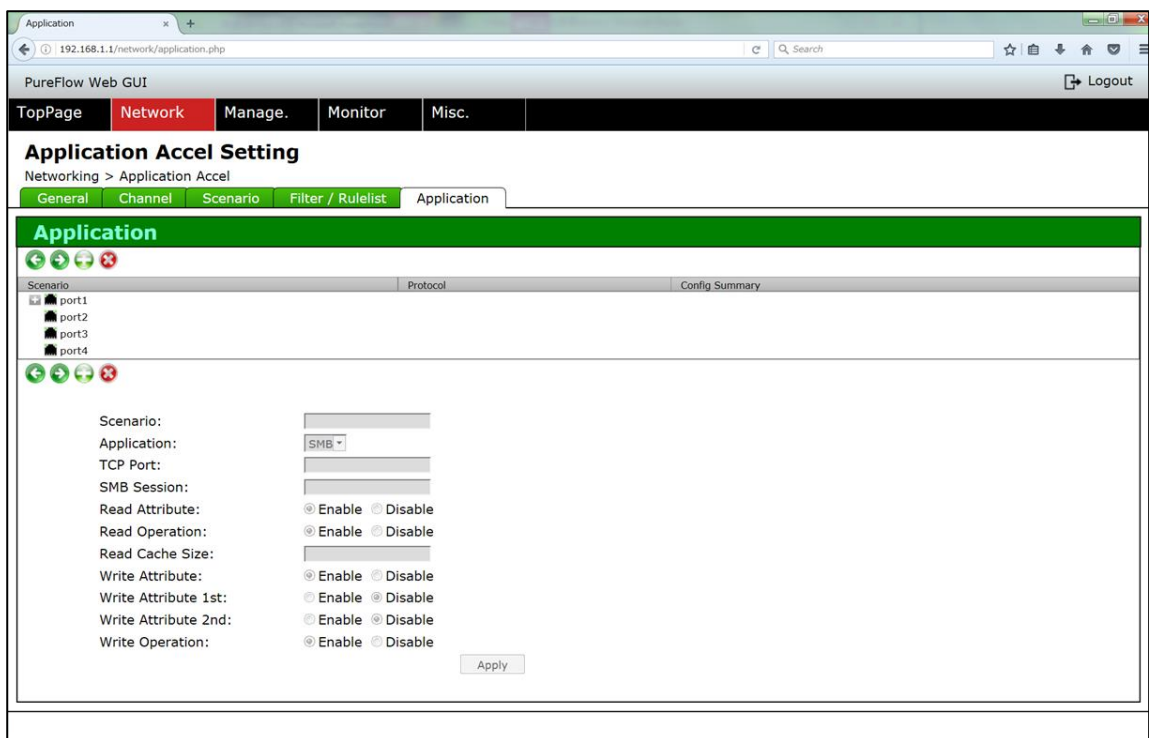

<1> Select the scenario to accelerate the application in the "Application" window, and <2> click the [+] button in green.

In the "Application" window, <3> select Application, and <4> enter each parameter. <5> Click the [Apply] button.

* If the above steps are performed for the scenario in which the application acceleration settings have already been registered, the existing parameter is overwritten with a new parameter.

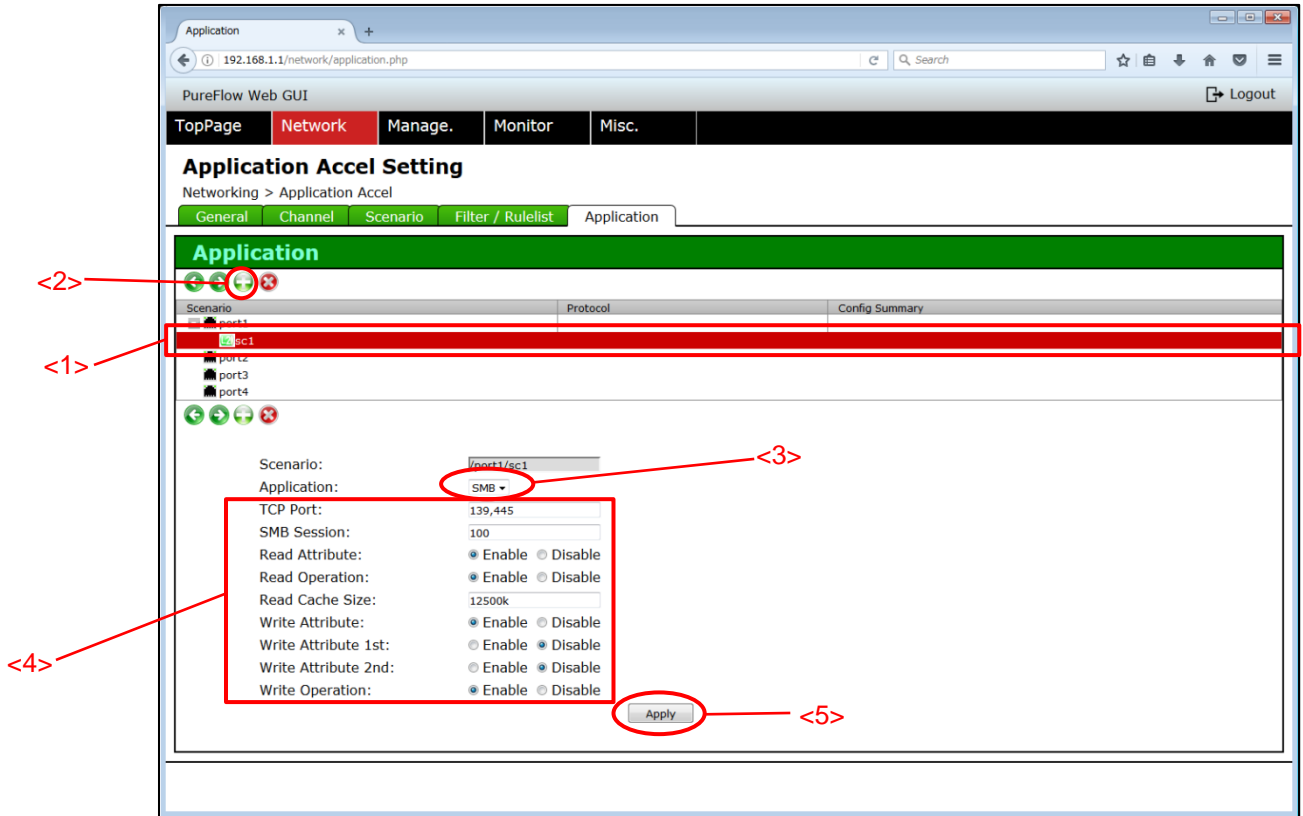

Check that the <6> [+] button in gray appears at the scenario in which the application acceleration setting was registered.

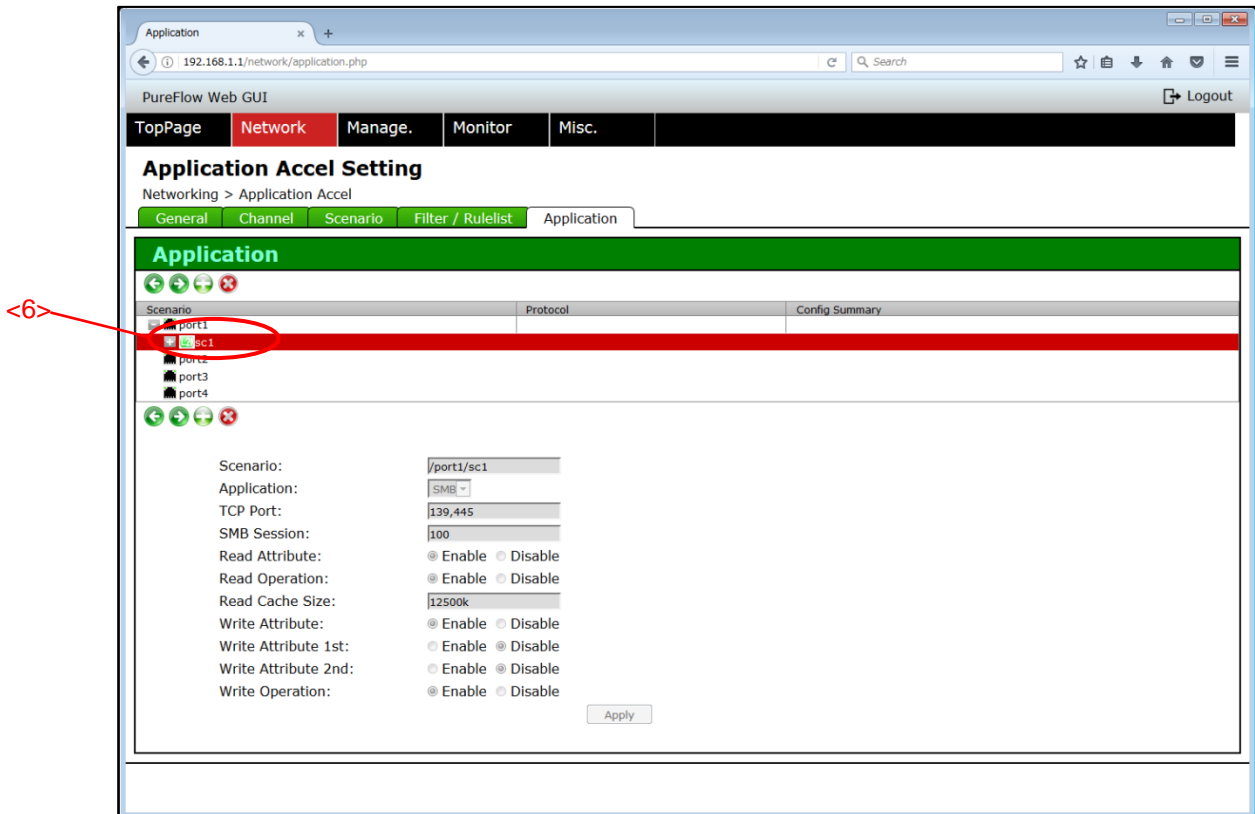

Clicking the [+] button in gray displays the application acceleration setting entry linked with the scenarios.

To delete the application acceleration setting, first, <7> select the scenario where the relevant application is set, then, <8> select the application to be deleted, and <9> click the [x] button in red.

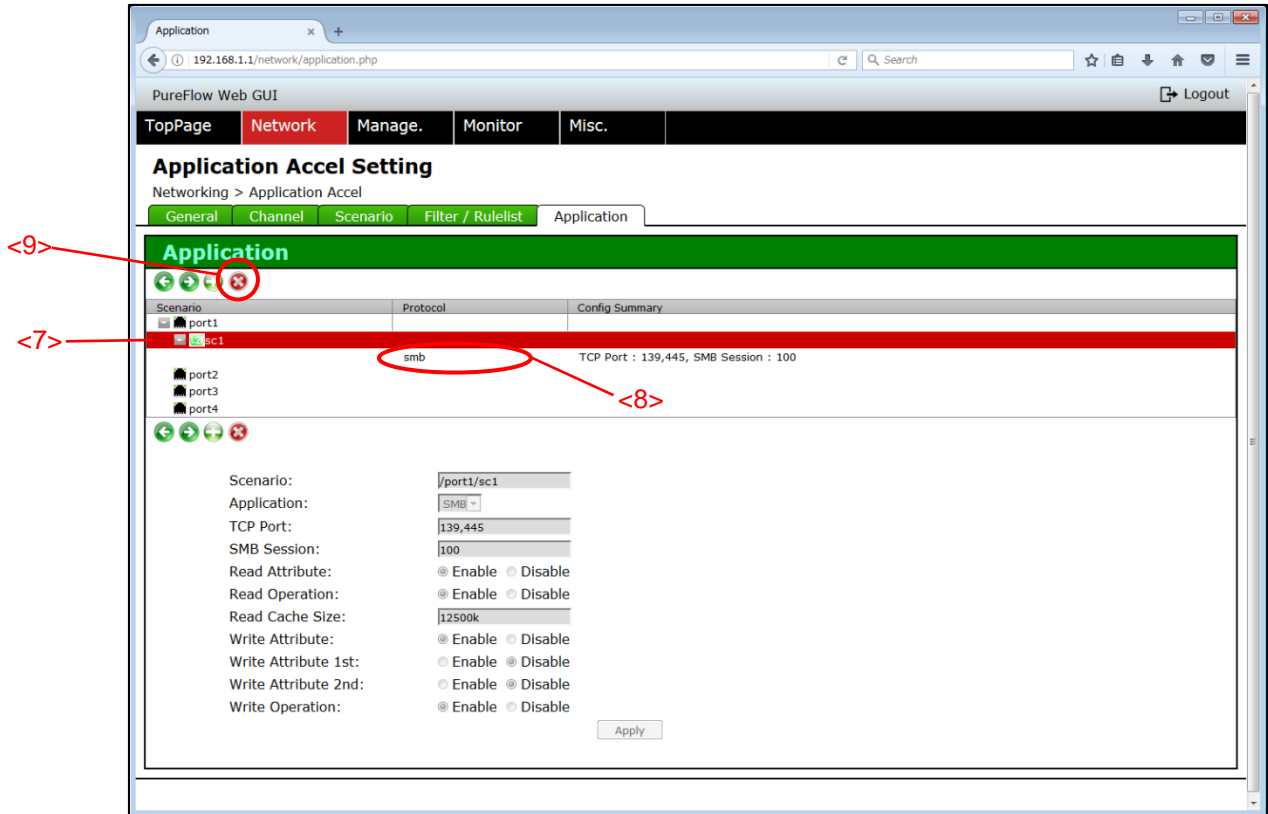

3
Operation Method

3.10 How to Configure Filter

Configure the filter.

* To configure the filter, configure the scenario in advance.

Place the mouse cursor on the [Network] tab at upper left of the screen. The pull-down menu of the Network menu appears. Click the [Filter / Rulelist] tab.

The Filter / Rulelist configuration screen appears as shown below.

The screenshot displays the 'Filter and Rulelist Setting' page in the PureFlow Web GUI. The browser address bar shows '192.168.1.1/network/filterandrule.php'. The navigation menu includes 'TopPage', 'Network', 'Manage.', 'Monitor', and 'Misc.'. The 'Network' menu is expanded, showing 'Filter / Rulelist' and 'Application' tabs. The 'Filter / Rulelist' tab is active, showing a 'Filter' section with a table of scenarios and a configuration form. The 'Rulelist' section is also visible below the filter configuration.

Filter Configuration Form:

- Filter Name:
- Scenario:
- Type:
- VLAN ID:
- Inner VLAN ID:
- CoS:
- Inner CoS:
- Source IP: Rulelist
- Destination IP: Rulelist
- ToS:
- Protocol: The Setting range is [TCP,UDP,ICMP] or [0-255].
- Source Port: Rulelist
- Destination Port: Rulelist
- Priority:

Rulelist Configuration Form:

- List Name:
- Type:
- Entry:

<1> Select the desired filter in the "Filter" window.

In the "Filter" window, <2> enter each parameter, and <4> click the [Add Filter] button. To use a rule list as a parameter, <3> select the rule list, and <4> click the [Add Filter] button.

For details of how to set the rule list, refer to "3.11 How to Set Rule List".

The screenshot displays the 'Filter and Rulelist Setting' page. At the top, there are navigation tabs: 'TopPage', 'Network', 'Manage.', 'Monitor', and 'Misc.'. Below this is the page title 'Filter and Rulelist Setting' and a breadcrumb 'Networking > Filter / Rulelist'. There are sub-tabs: 'General', 'Channel', 'Scenario', 'Filter / Rulelist', and 'Application'. The main content area is titled 'Filter' and contains a table with columns: Scenario, Filter Name, Type, Config Summary, and Priority. The table lists several filters, with 'sc1' under the 'Scenario' column highlighted by a red box and labeled with '<1>'. Below the table is a configuration form for a selected filter. The form fields are: Filter Name (filter1), Scenario (/port1/sc1), Type (IPv4), VLAN ID (10), Inner VLAN ID, CoS, Inner CoS, Source IP (192.168.1.10), Destination IP, ToS, Protocol, Source Port, Destination Port, and Priority. A red box and arrow labeled '<2>' encompasses the form fields. To the right of the form, there are two 'Rulelist' selection buttons, each with a 'Select Rulelist' button next to it. A red box and arrow labeled '<3>' highlights these buttons. At the bottom right of the form area is an 'Add Filter' button, which is circled in red and labeled with '<4>'. On the far right of the page, there is a large number '3' and the text 'Operation Method' written vertically.

Check that the <5> [+] button in gray appears at the relevant scenario as shown below. This button appears to indicate the existence of the filters of the scenario.

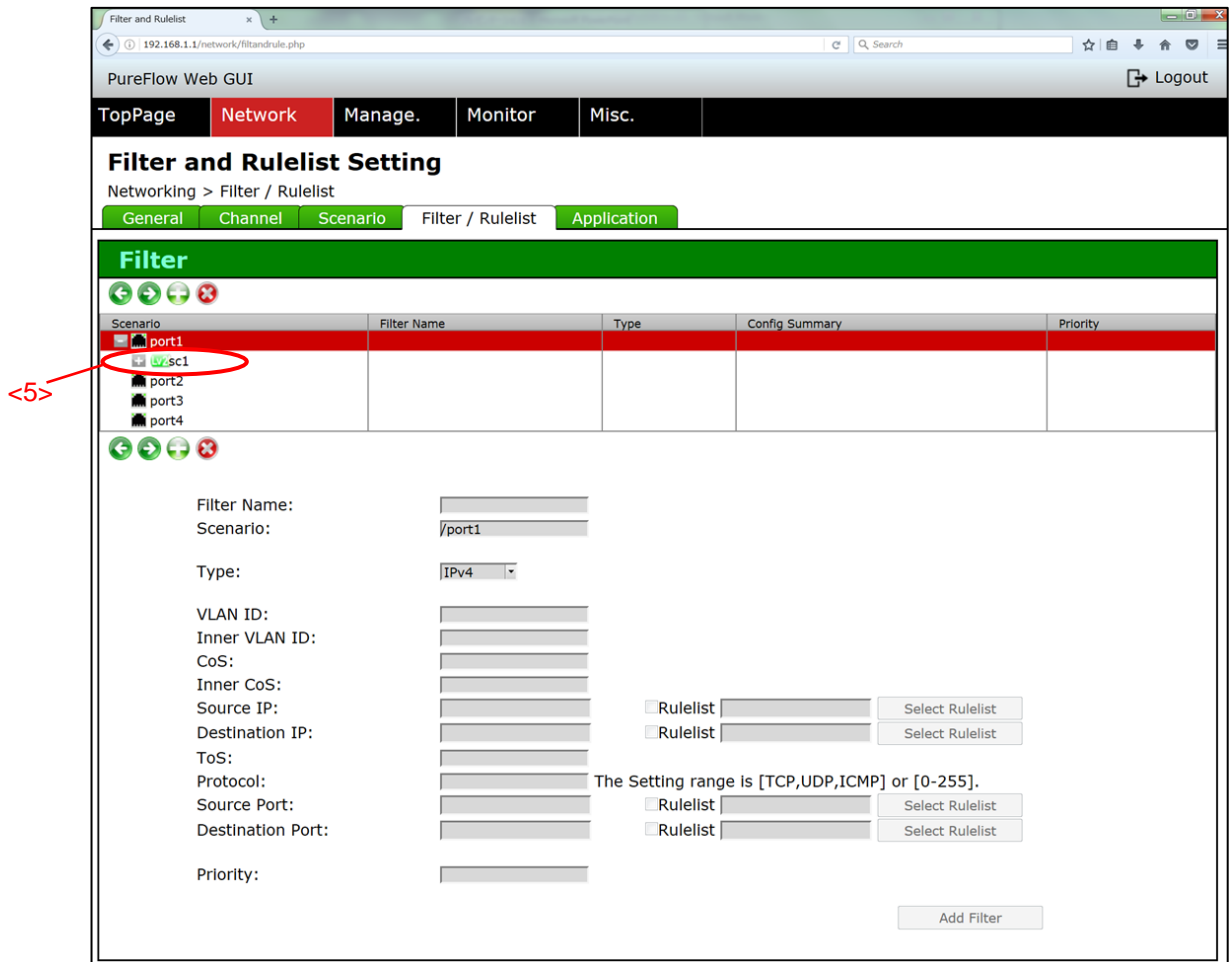

Clicking the [+] button in gray displays the filters linked with the scenarios. By selecting the relevant filter, the parameter of the scenario can be checked.

To delete the filter or change the parameter, <6> select the relevant filter. To delete the filter, <7> click the [x] button in red.

The screenshot shows the 'Filter and Rulelist Setting' page in the PureFlow Web GUI. The page is titled 'Filter and Rulelist Setting' and is part of the 'Networking > Filter / Rulelist' section. There are five tabs: 'General', 'Channel', 'Scenario', 'Filter / Rulelist', and 'Application'. The 'Filter / Rulelist' tab is active.

Under the 'Filter' heading, there are four icons: a plus sign, a left arrow, a right arrow, and a red 'x' icon. A red arrow labeled '<7>' points to the red 'x' icon.

Below the icons is a table with the following columns: Scenario, Filter Name, Type, Config Summary, and Priority. The table contains several rows, with the row for 'joy' highlighted in red. A red arrow labeled '<6>' points to this row.

Scenario	Filter Name	Type	Config Summary	Priority
port1				
sc1	joy	IPv4	VLAN ID : 10 , SIP : 192.168.1.10-192.168.1.10	20000
port2				
port3				
port4				

Below the table is a configuration form for the selected filter. The fields are as follows:

- Filter Name: joy
- Scenario: /port1/sc1
- Type: IPv4
- VLAN ID: 10
- Inner VLAN ID: (empty)
- CoS: (empty)
- Inner CoS: (empty)
- Source IP: 192.168.1.10-192.168.1.10
- Destination IP: (empty)
- ToS: (empty)
- Protocol: (empty)
- Source Port: (empty)
- Destination Port: (empty)
- Priority: 20000

There are also checkboxes for 'Rulelist' and 'Select Rulelist' buttons for Source IP, Destination IP, Source Port, and Destination Port. A note says 'The Setting range is [TCP,UDP,ICMP] or [0-255]'. An 'Add Filter' button is at the bottom right.

3.11 How to Set Rule List

Set the rule list.

Divide the rule list into the rule list group and rule list entry, and set them.

3.11.1 How to set rule list group

Set the rule list group.

Place the mouse cursor on the [Network] tab at upper left of the screen.

The pull-down menu of the Network menu appears. Click the [Filter / Rulelist] tab.

The Filter / Rulelist configuration screen appears as shown below.

The screenshot shows a web browser window titled "Filter and Rulelist" at the URL "192.168.1.1/network/fitandrule.php". The browser's address bar and navigation icons are visible. The page has a dark navigation bar with tabs: "TopPage", "Network" (highlighted in red), "Manage.", "Monitor", and "Misc.". Below the navigation bar, the "Filter" configuration section contains the following fields and controls:

- Destination IP: [text input] Rulelist [text input] Select Rulelist
- Protocol: [text input] The Setting range is [TCP,UDP,ICMP] or [0-255].
- Source Port: [text input] Rulelist [text input] Select Rulelist
- Destination Port: [text input] Rulelist [text input] Select Rulelist
- Priority: [text input] 20000
- [Add Filter] button

The "Rulelist" section is highlighted with a green header and contains:

- Table with columns: ListName, Type, Entry
- Form to add a new group:
 - List Name: [text input]
 - Type: [dropdown menu] IPv4
 - Entry: [text input]
 - [Add Group] button

- <1> Click the [+] button in green in the "Rulelist" window.
- <2> Enter the desire name in the "List Name" column, select "Type", and
- <3> click the [Add Group] button.

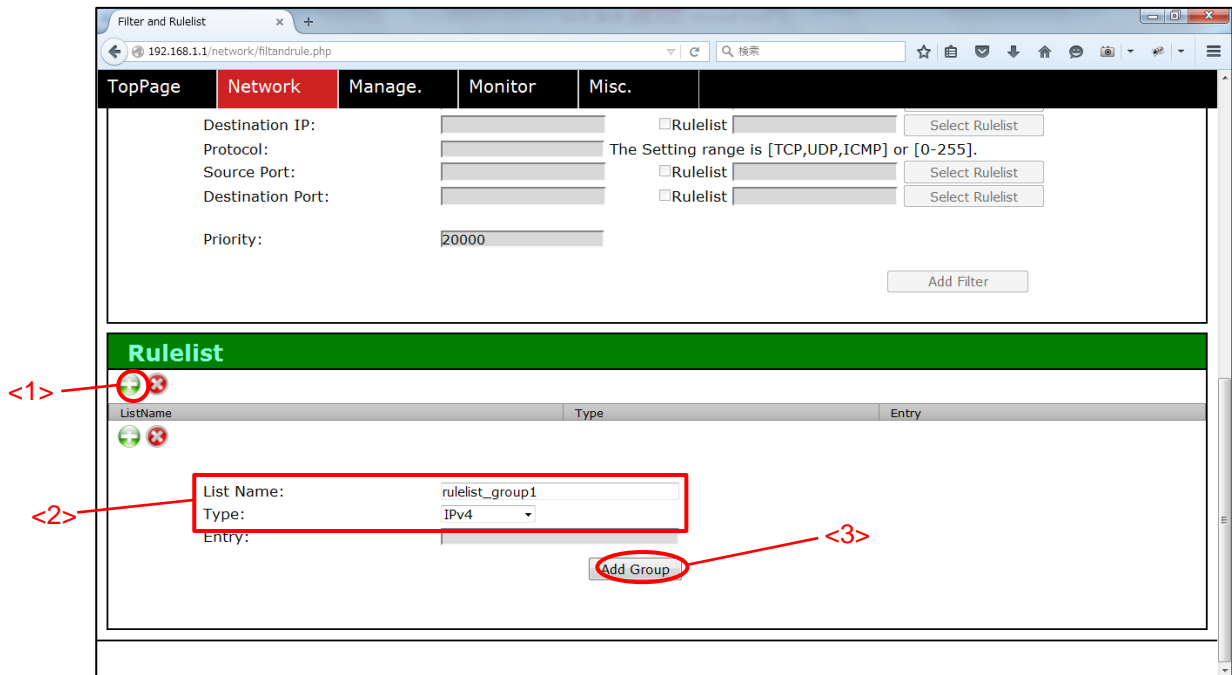

3
Operation Method

- Check that the set rule list group as shown below.
- To delete the list group, <4> select the relevant rule list group, and <5> click the [x] button in red.

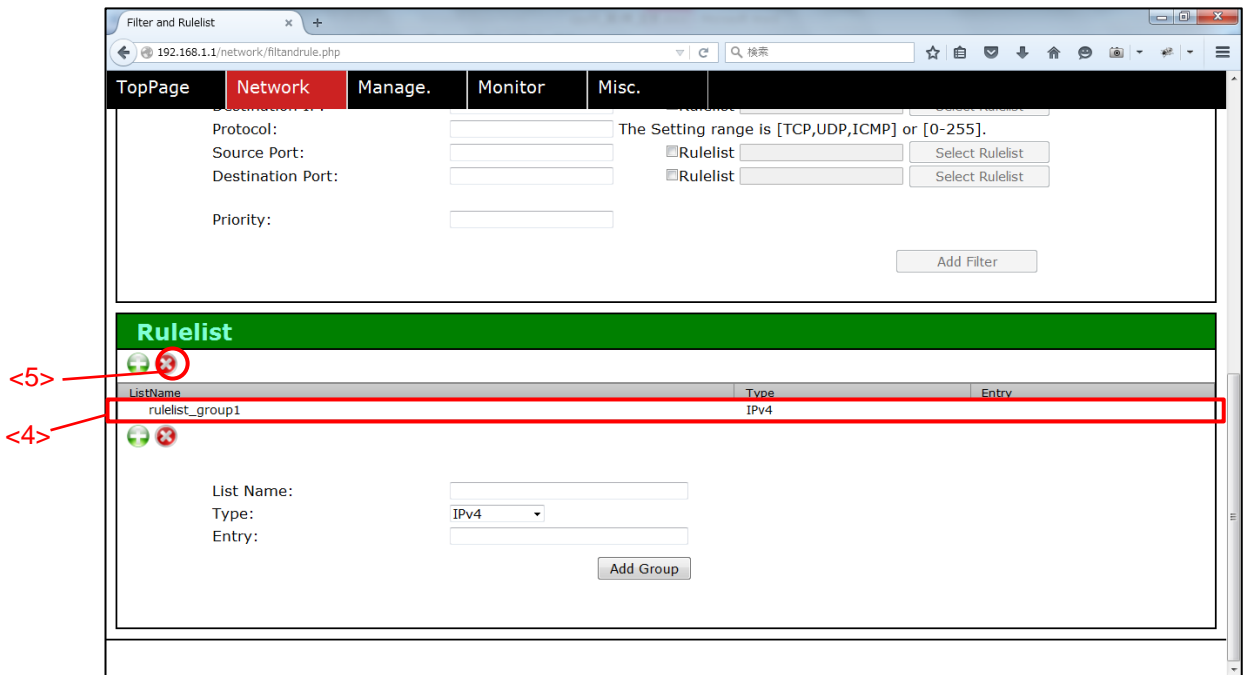

3.11.2 How to set rule list entry

Set the rule list entry.

* To set the rule list entry, set the rule list group in advance.

<1> Select the relevant rule list group, <2> enter the IP address or port number in the [Entry] column, and <3> click the [Add Entry] button.

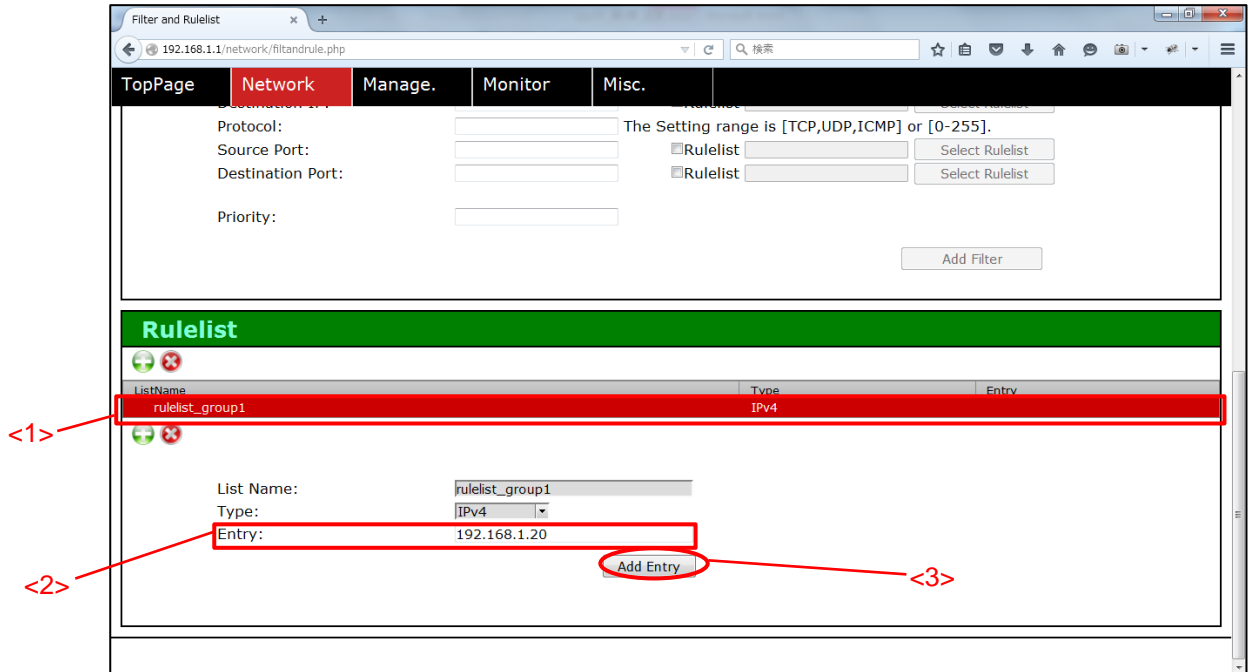

Check that the [+] button in gray appears at the relevant rule list group as shown below. This button appears to indicate the existence of the rule list entry of the scenario.

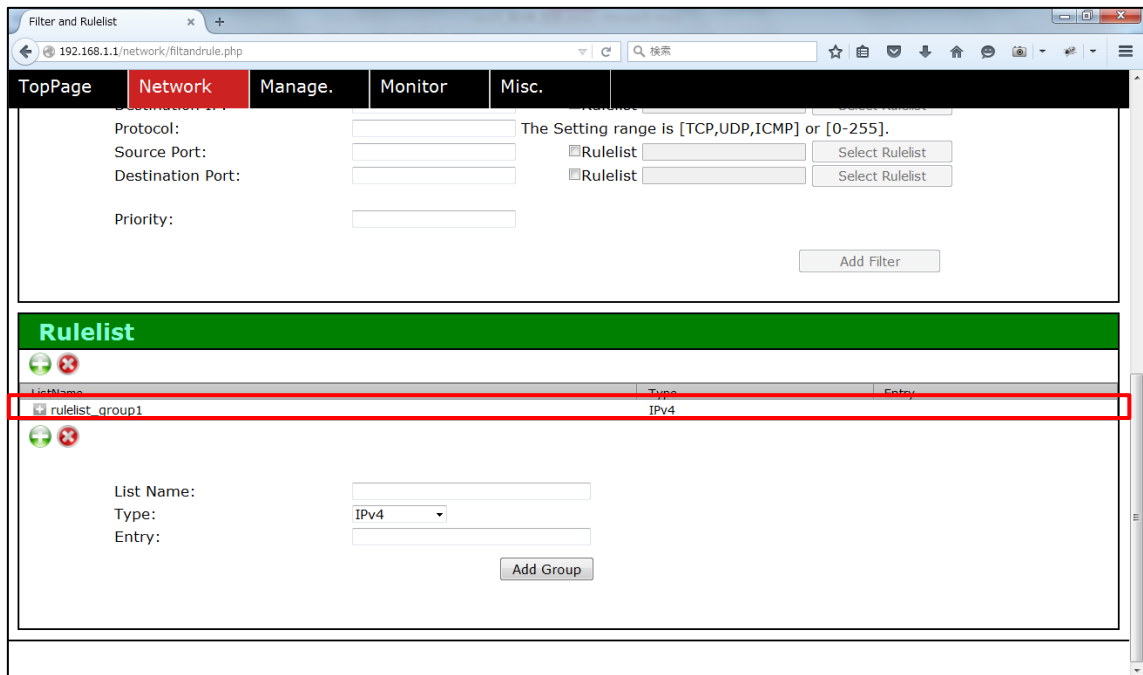

3

Operation Method

By clicking the [+] button in gray, the parameters of the rule list entry set in the rule list group can be checked.

To delete the rule list entry, select the relevant rule list entry, and click the [x] button in red according to the same procedure as the rule list group.

3.12 How to Perform Settings Related to Time

Perform the settings related to the current time.

Place the mouse cursor on the [Manage.] tab at upper left of the screen.

The pull-down menu of the Manage. menu appears. Click the [Time] tab.

The Time Config screen appears as shown below.

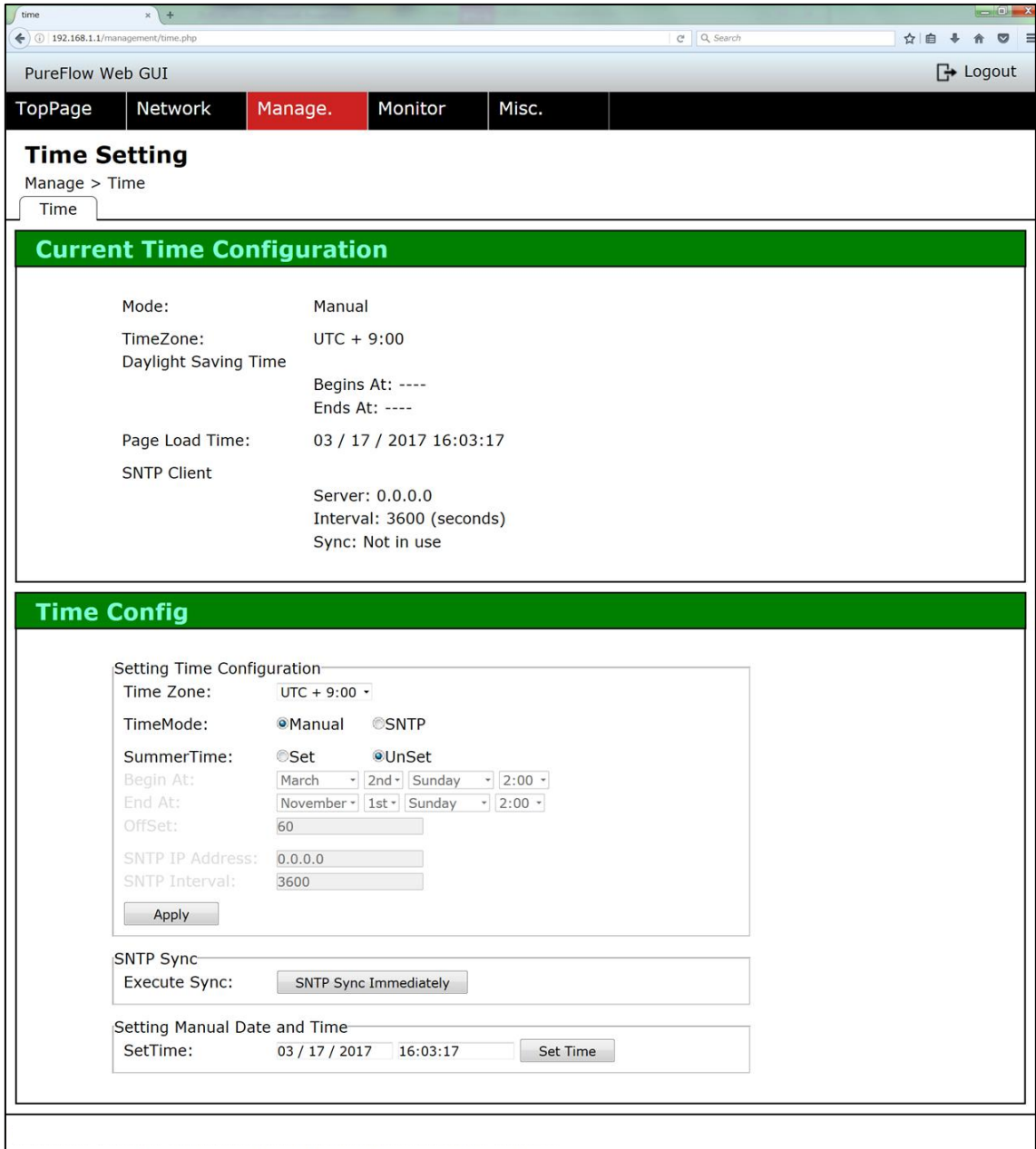

3.12.1 How to set time zone

Set the time zone.

- <1> Select a time zone from "Time Zone" in the "Time Config" window,
- and <2> click the [Apply] button.

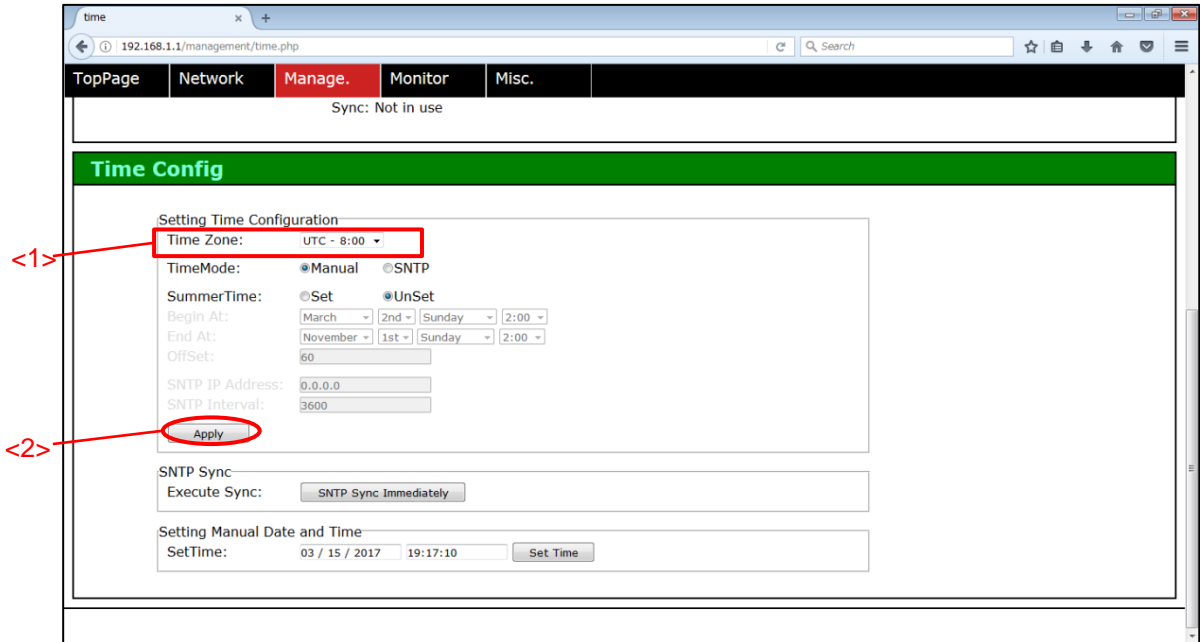

3
Operation Method

Check that "TimeZone" in the "Current time configuration" window has been changed as shown below.

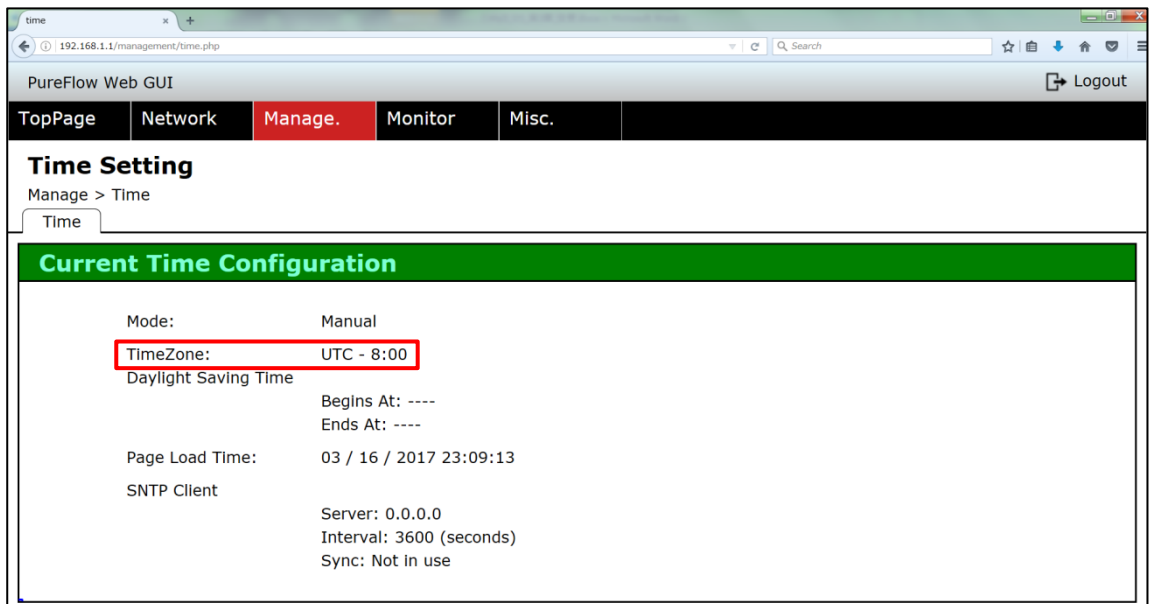

3.12.2 How to set daylight-saving time

Set the daylight-saving time.

In the "Time Config" window, <1> Select "Set" in "SummerTime", <2> enter/select parameters respectively, and <3> click the [Apply] button.

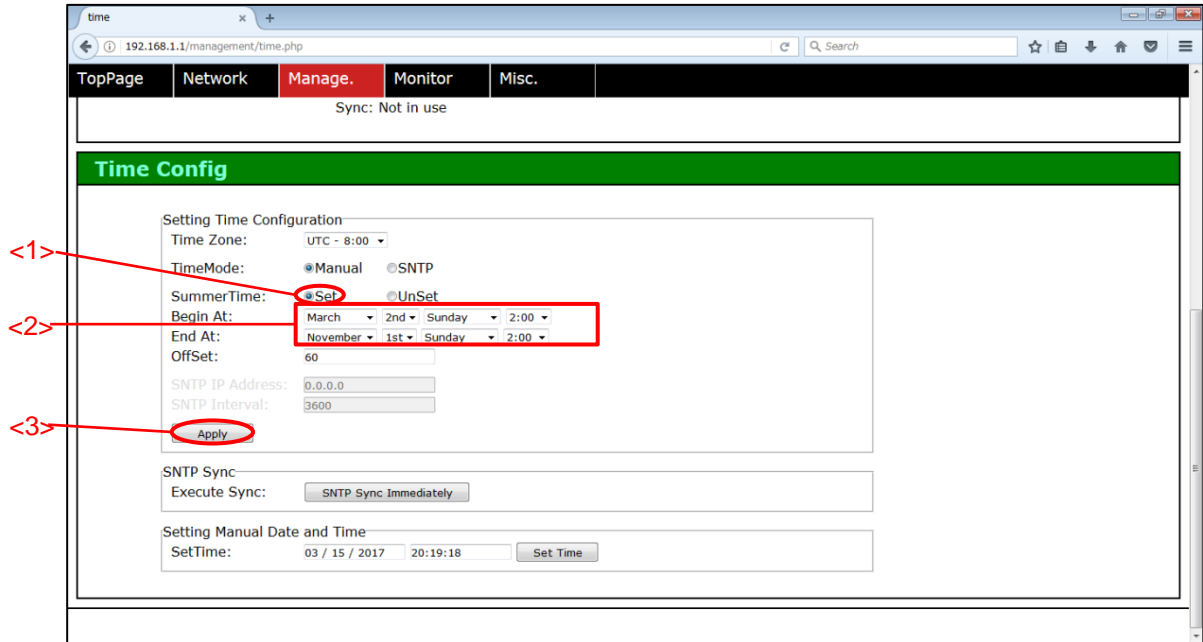

Check that "Daylight Saving Time" in the "Current Time Configuration" window has been changed as shown below.

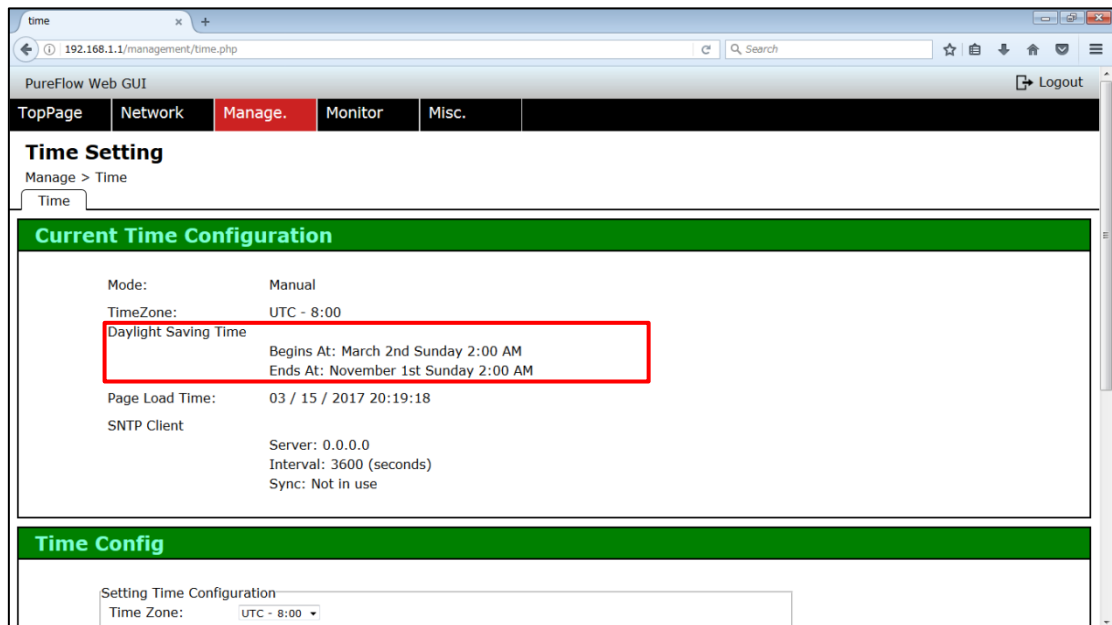

3.12.3 How to set SNTP

Set SNTP.

<1> Select SNTP in "Time Mode" of the "Time Config" window.

<2> Enter parameters in "SNTP IP Address" and "SNTP Interval", respectively, and <3> click the [Apply] button.

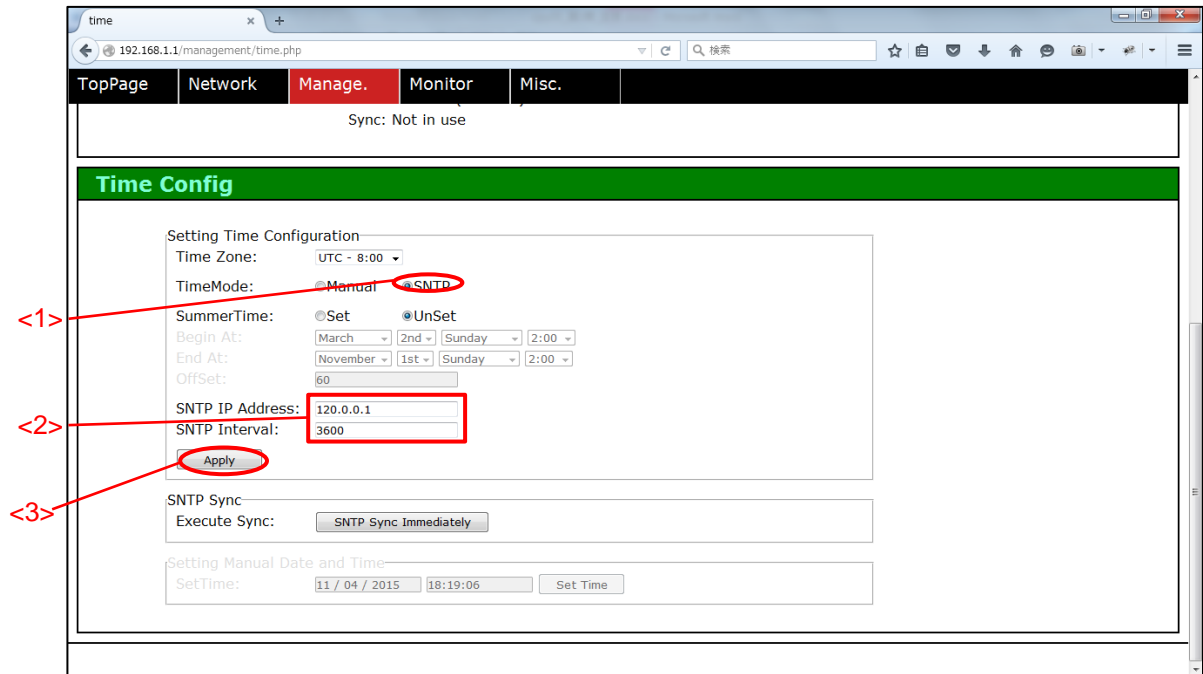

3

Operation Method

Check that "Mode" in "Current Time Configuration" is "SNTP" and parameters of "SNTP Client" have been changed as shown below.

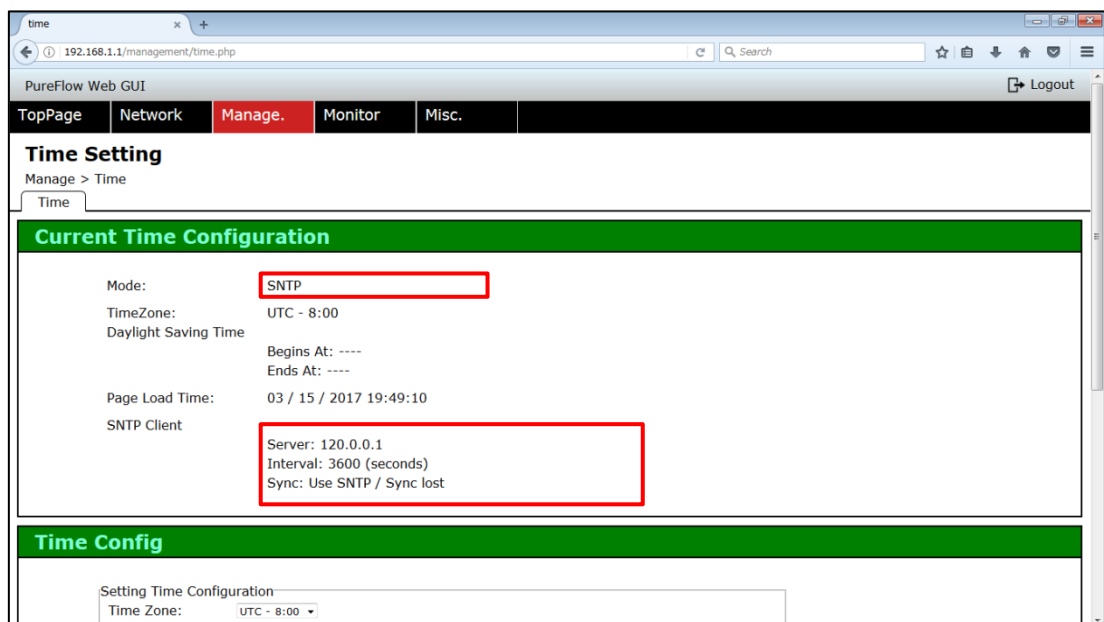

SNTP is synchronized with the SNTP server automatically at the interval of specified "SNTP Interval". In addition, synchronization with the SNTP server can be performed at the desired timing by clicking the [SNTP Sync Immediately] button of the "Execute Sync" column in the "Time Config" window.

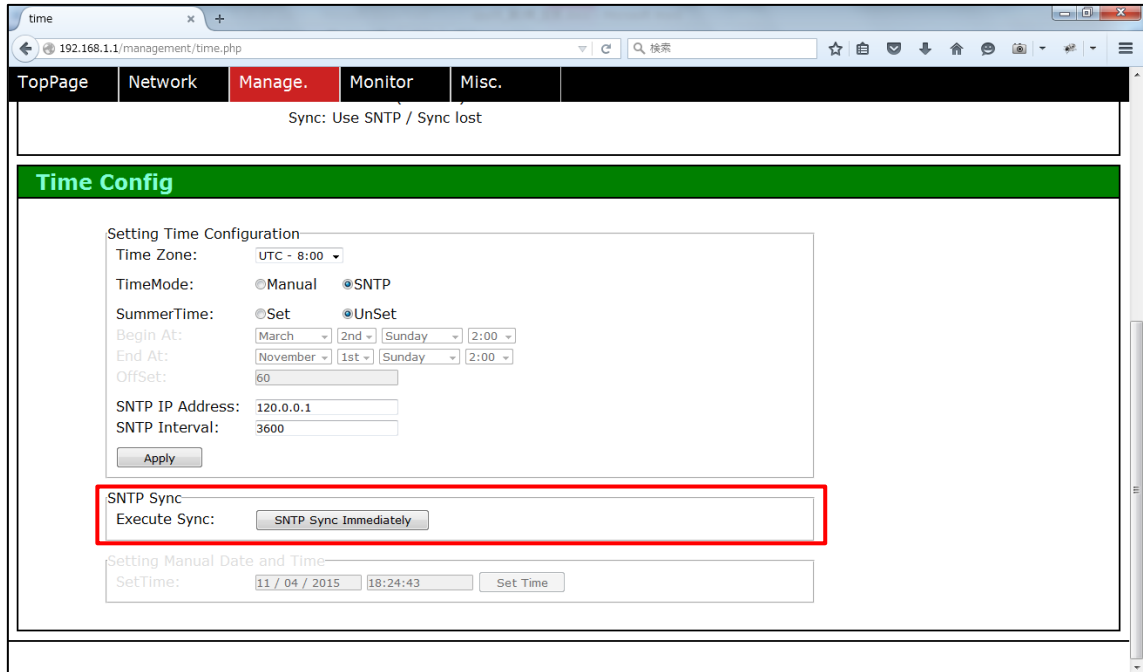

3.12.4 How to set time manually

Set the time manually.

- <1> Select "Manual" in "Time Mode" of the "Time Config" window, and
- <2> click the [Apply] button.
- <3> Check that "Mode" in "Current Time Configuration" is "Manual".
- <4> Enter the current date(MM/DD/YYYY) and time(hh:mm:ss) in the "Set Time" column of the "Time Config" window, and <5> click the [Set Time] button.

The screenshot displays the PureFlow Web GUI interface for time configuration. The browser address bar shows `192.168.1.1/management/time.php`. The navigation menu includes **TopPage**, **Network**, **Manage.**, **Monitor**, and **Misc.**. The main content area is titled **Time Setting** and contains two sections:

- Current Time Configuration:** This section shows the current system settings. A red box highlights the **Mode: Manual** setting, with a red arrow labeled <3> pointing to it. Other visible settings include TimeZone: UTC + 9:00, Daylight Saving Time (Begins/Ends At: ----), Page Load Time: 03 / 17 / 2017 16:03:17, and SNTP Client (Server: 0.0.0.0, Interval: 3600 seconds, Sync: Not in use).
- Time Config:** This section allows for manual configuration. A red arrow labeled <1> points to the **TimeMode: Manual** radio button. Below it, the **Apply** button is circled in red, with a red arrow labeled <2> pointing to it. At the bottom, the **Setting Manual Date and Time** section has a red box around the **SetTime: 03 / 17 / 2017 16:03:17** input field (labeled <4>) and the **Set Time** button (labeled <5>).

Check that "Page Load Time" in "Current Time Configuration" indicates the specified time as shown below.

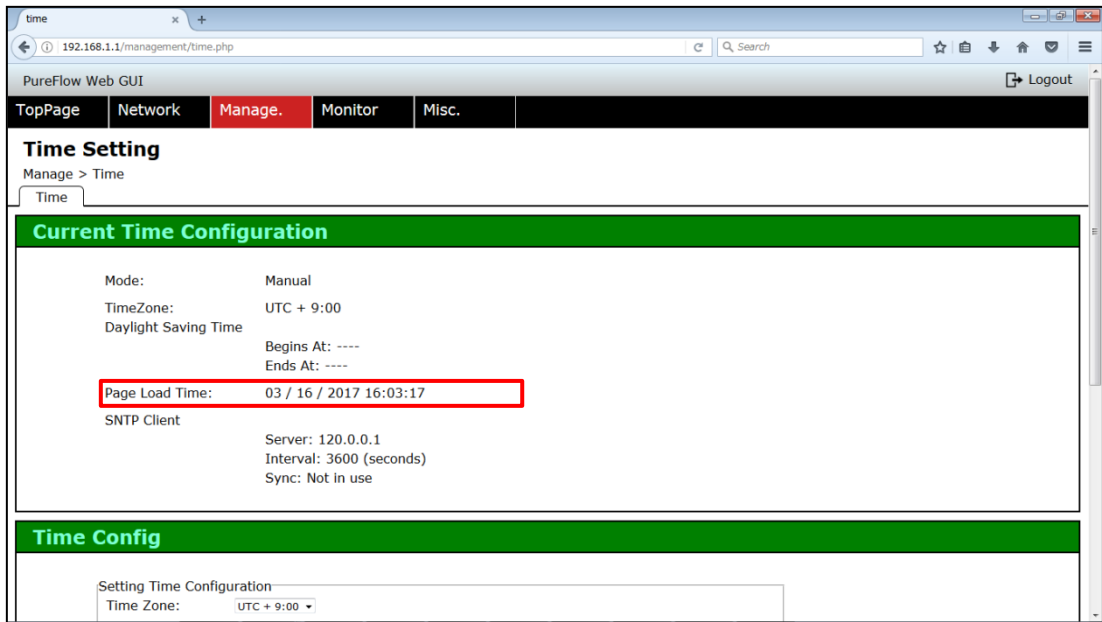

3.13 Setting Flow Identification Mode

Set the flow identification mode.

Place the mouse cursor on the [Network] tab in the upper left of the screen

The pull-down menu of the Network menu appears. Click the [General] tab.

The General Setting screen appears as shown below.

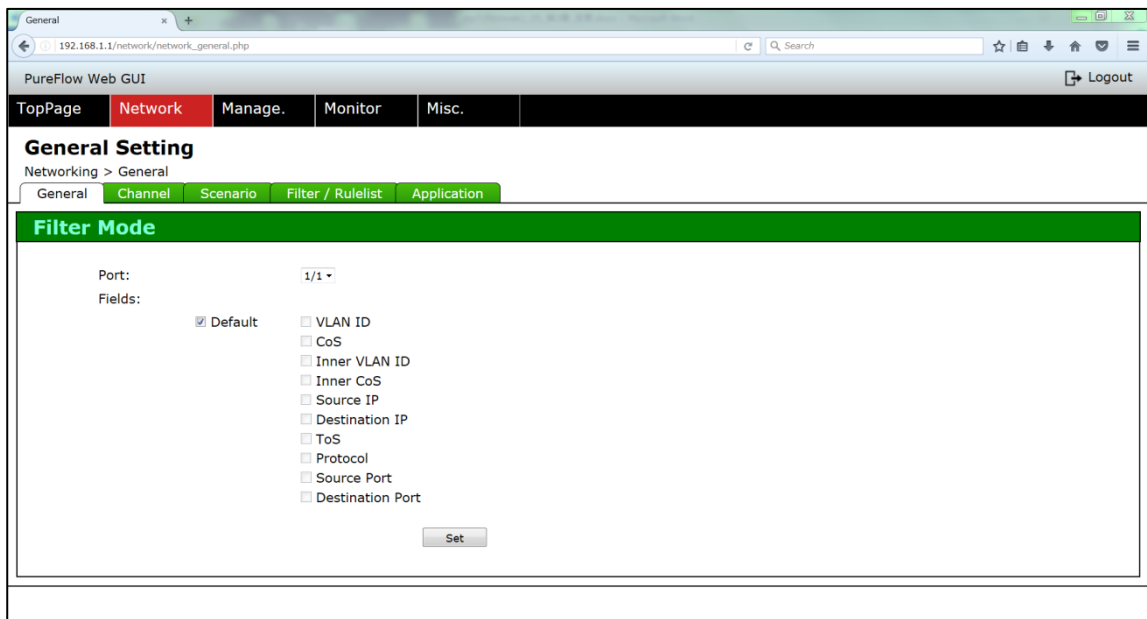

<1> Specify the slot position and port number in the "Filter Mode" window, and <2> select the field used for identification of the flow. <3> Click the [Set] button to set the flow identification mode.

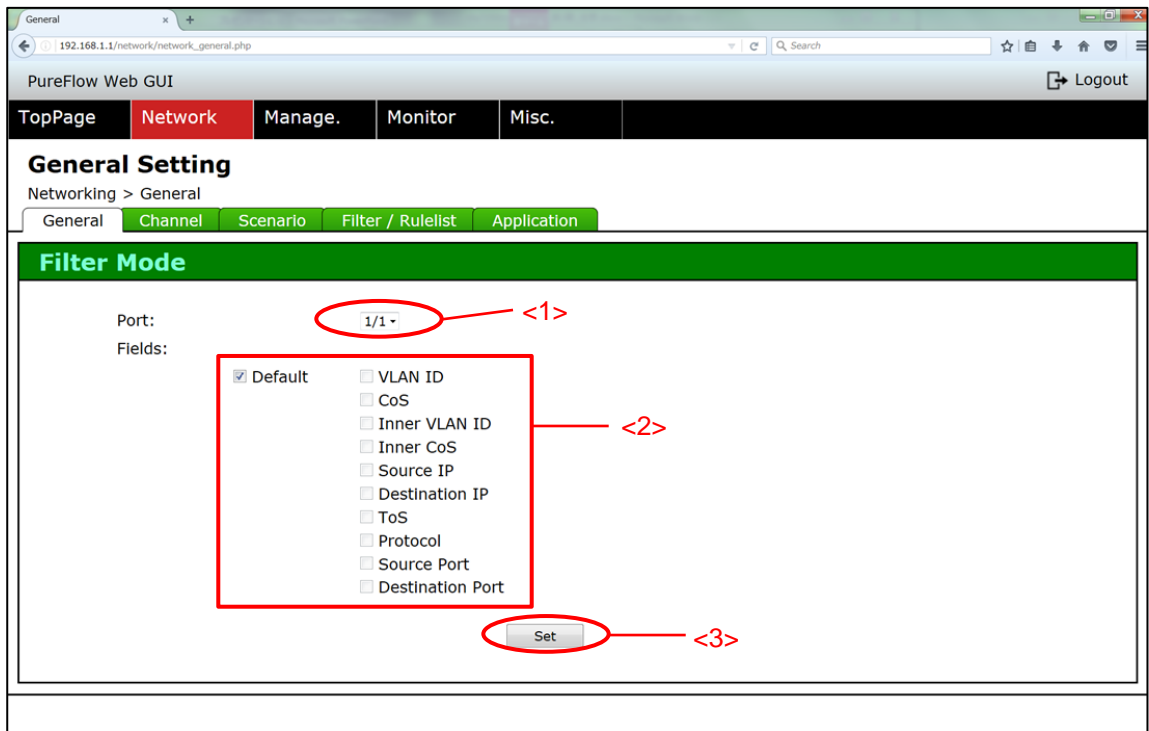

3.14 How to Display Traffic Graph of Scenario

Display the traffic graph of scenario.

Place the mouse cursor on the [Monitor] tab at upper left of the screen.

The pull-down menu of the Monitor menu appears. Click the [Scenario Traffic] tab.

The Scenario Traffic graph screen appears as show below.

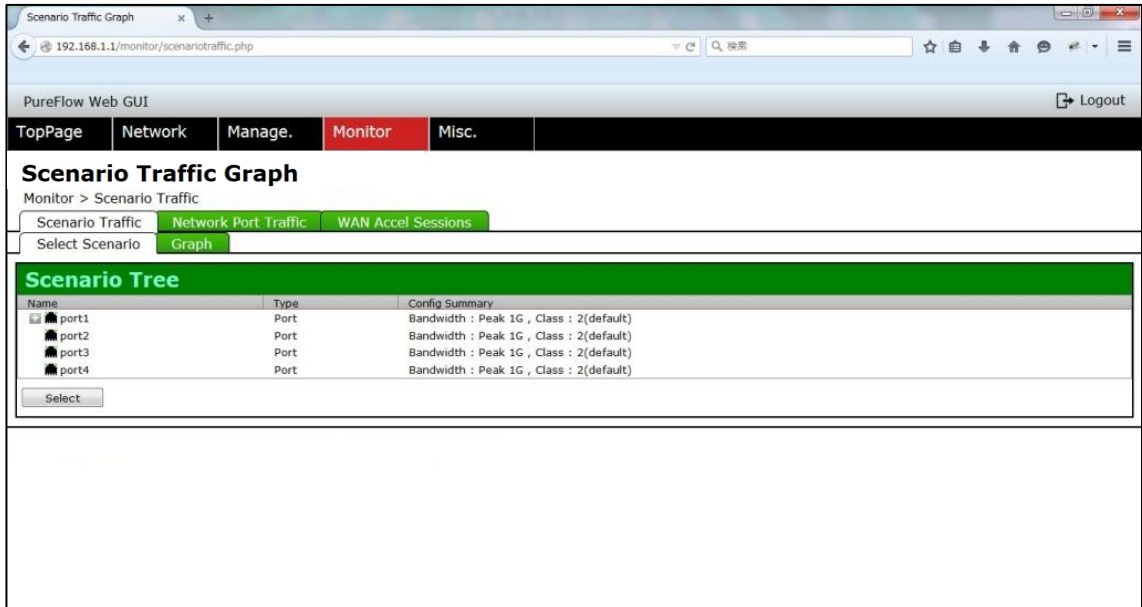

3

Operation Method

First, select the scenario to display the graph.

Click the [Select Scenario] tab of the "Scenario Traffic" window.

The scenario selection screen appears as show below.

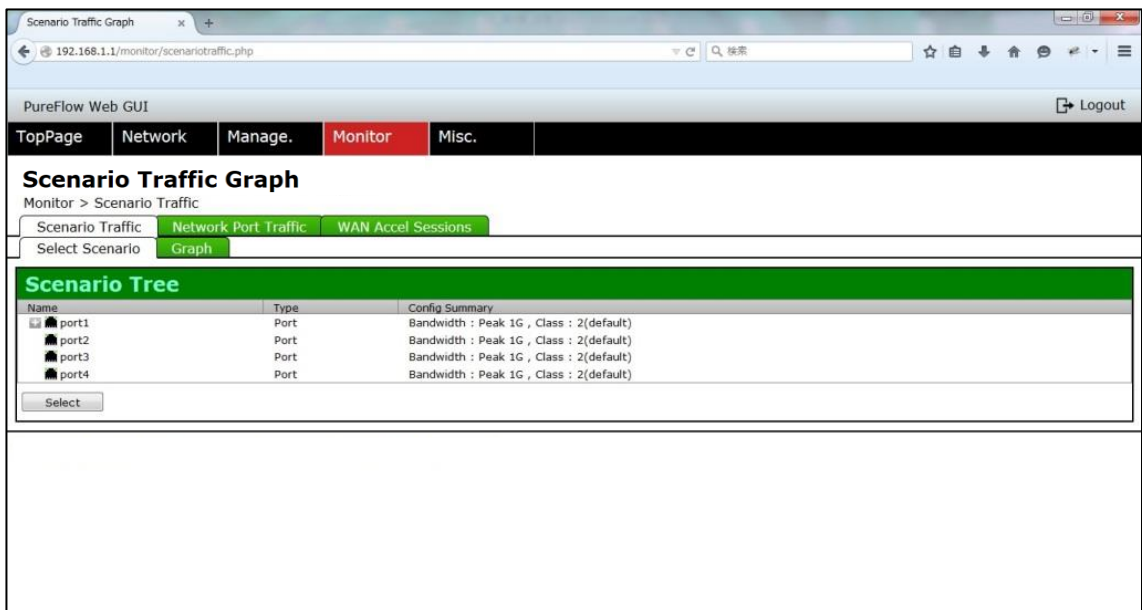

As an example, procedure for selecting a scenario on the 2nd layer for port1 is described below.

<1> Select "port1" in the "Scenario Tree" window, and click the [+] button in gray displays the scenarios on the 2nd layers.

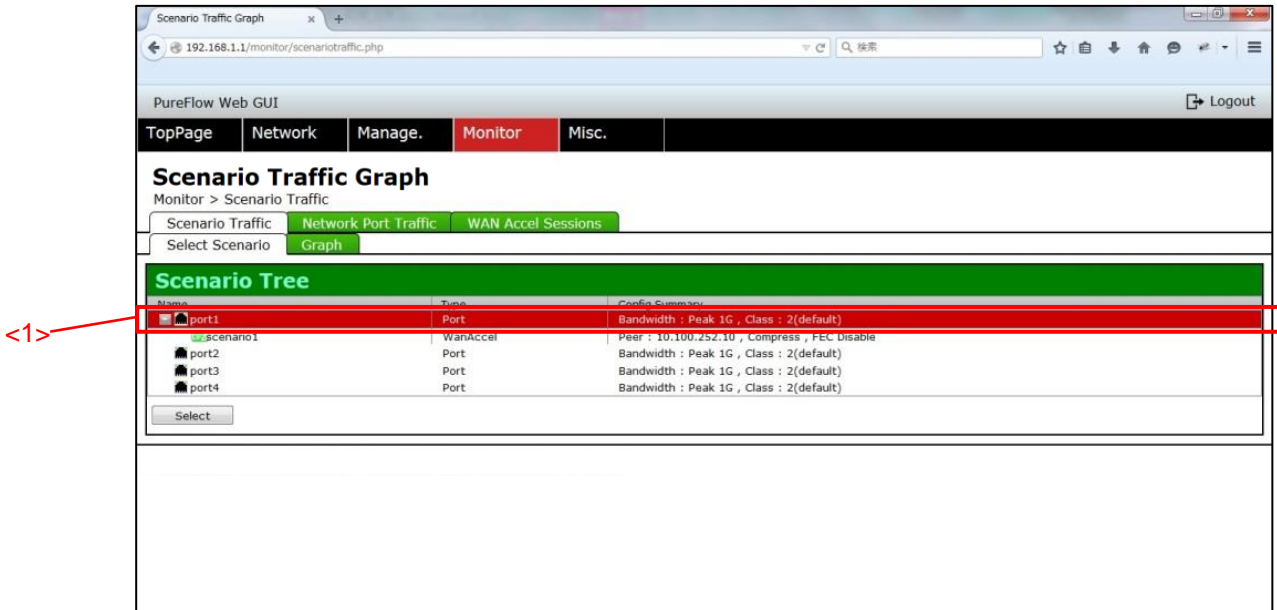

<2> select the relevant scenario, and <3> click the [Select] button.

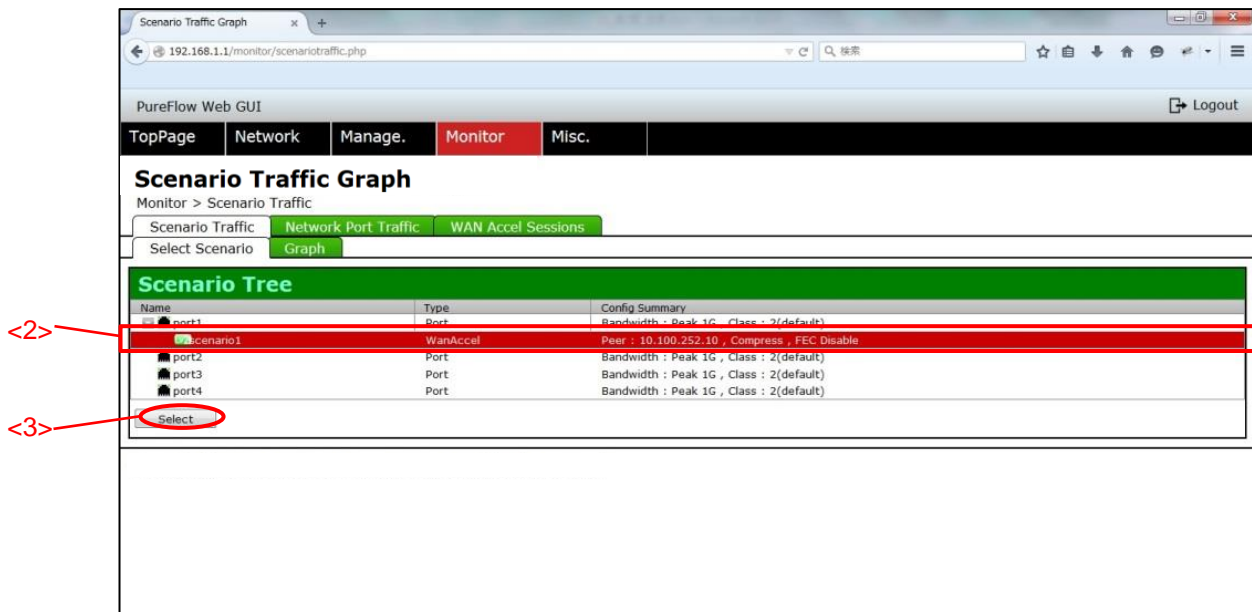

Click the [Graph] tab of the "Scenario Traffic" window.
 The transmit / receive traffic graph appears as shown below.

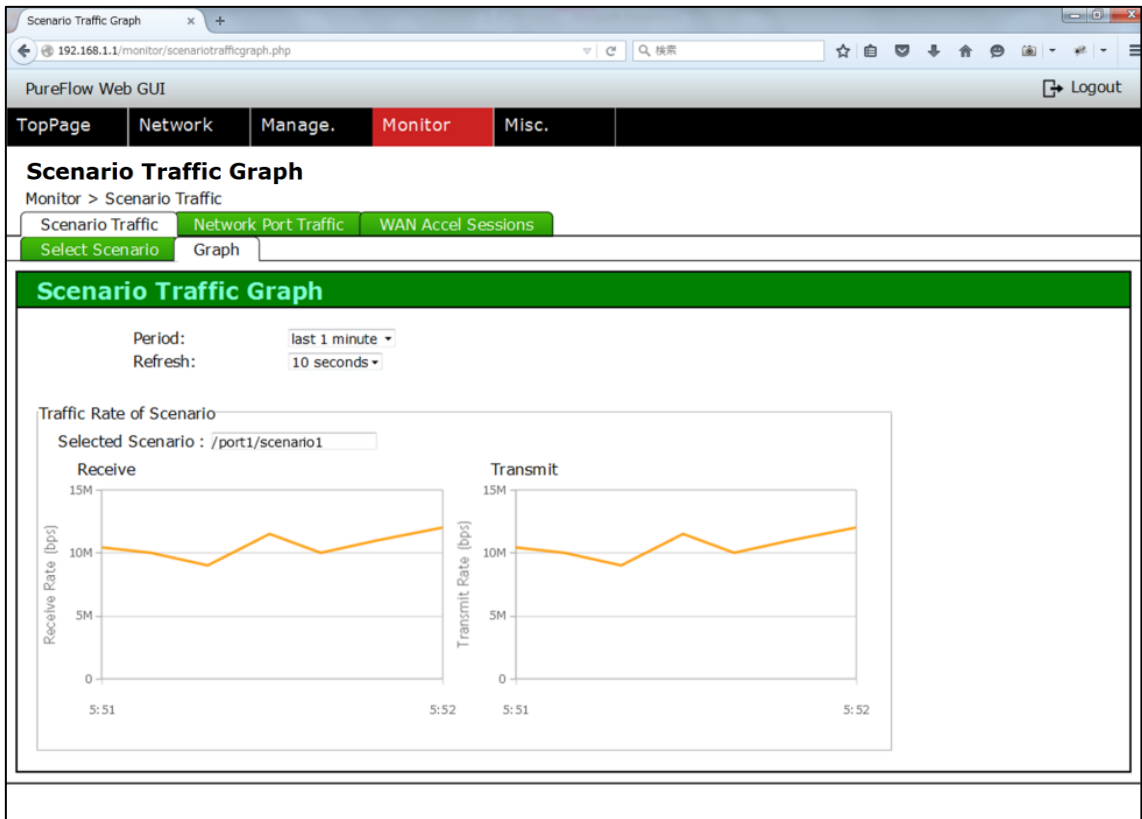

3
Operation Method

Check that the scenario has been changed as shown below.

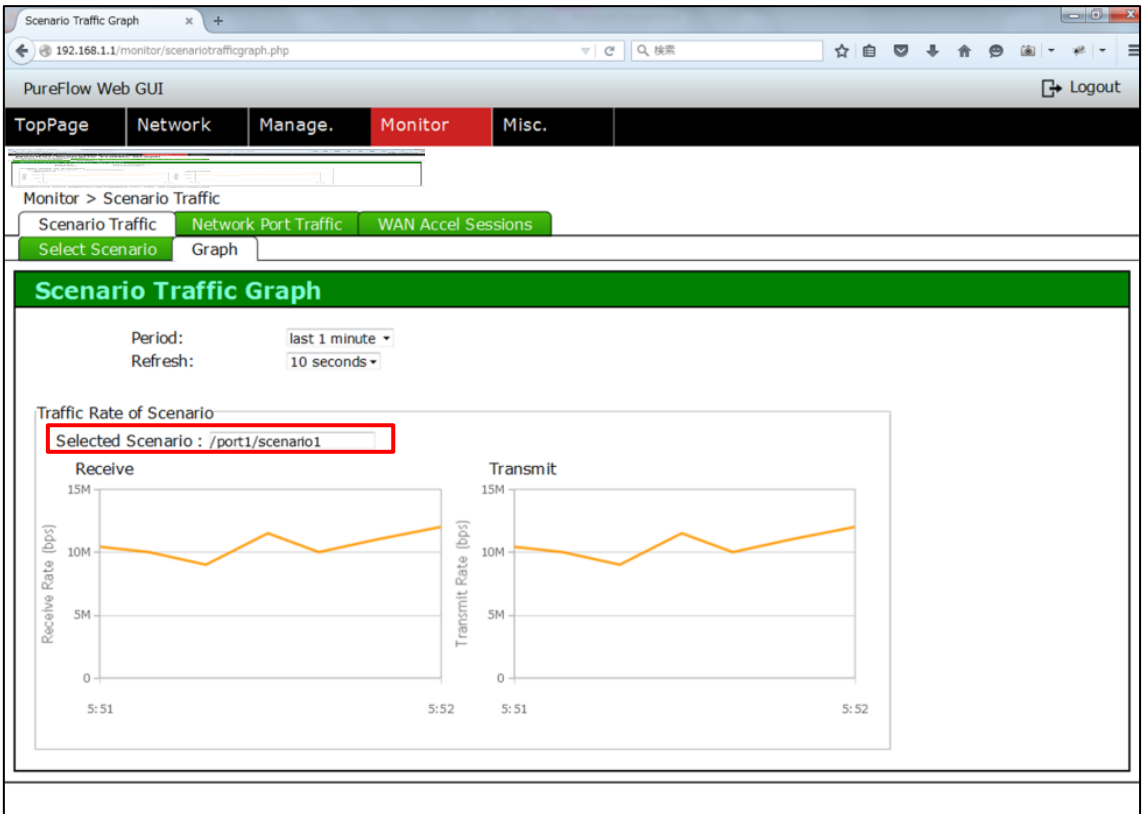

- <4> Range of the graph can be changed in “Period”.
- <5> Period of the graph can be changed in “Refresh”.

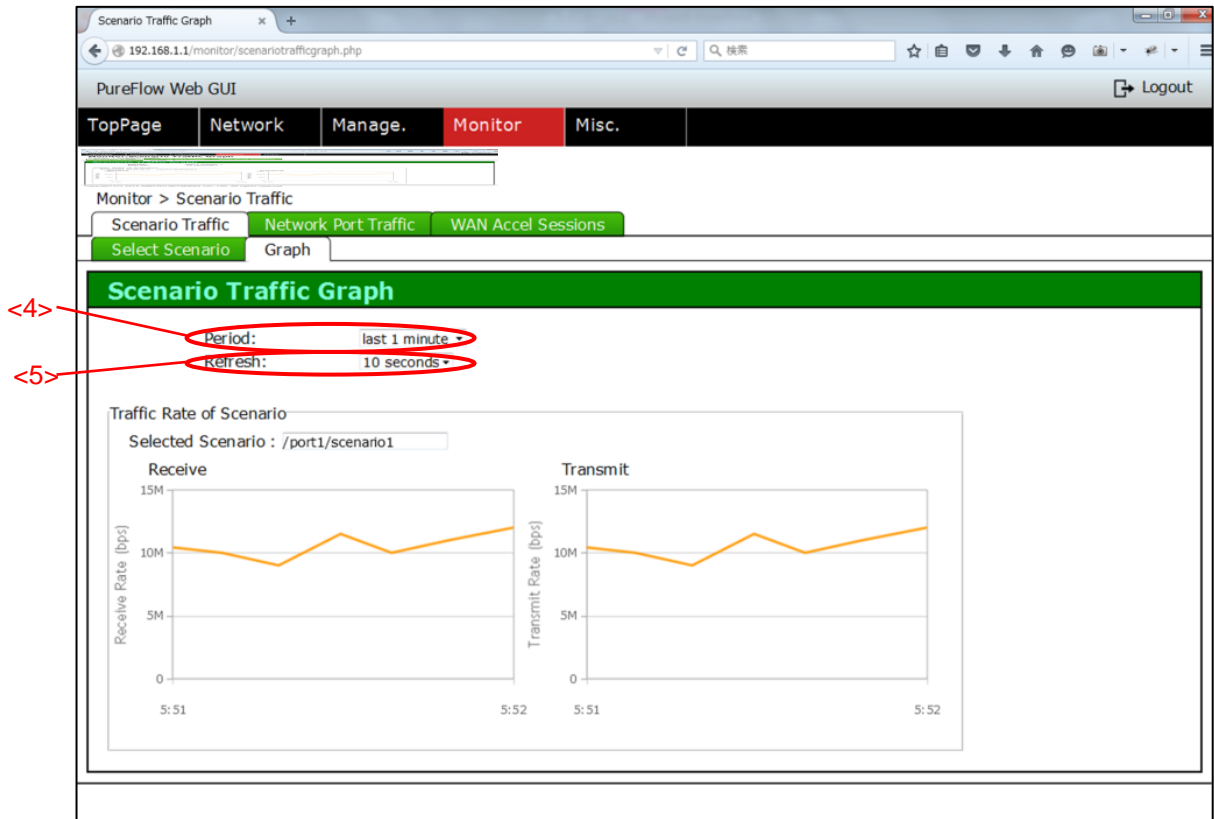

3.15 How to Display Traffic Graph of Network Port

Display the traffic graph of network port.

Place the mouse cursor on the [Monitor] tab at upper left of the screen.

The pull-down menu of the Monitor menu appears. Click the [Network Port Traffic] tab.

The Network Port Traffic graph screen appears as show below.

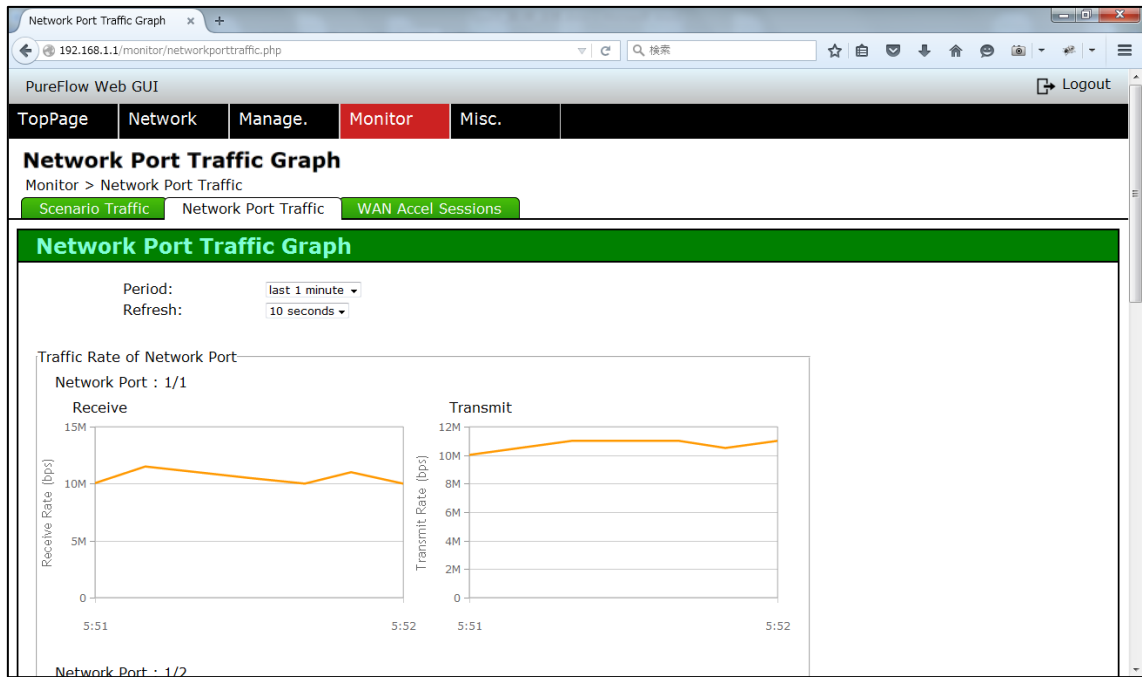

The transmit / receive traffic graph of network port in the "Network Port Traffic" window.



- <1> Range of the graph can be changed in “Period”.
- <2> Period of the graph can be changed in “Refresh”.

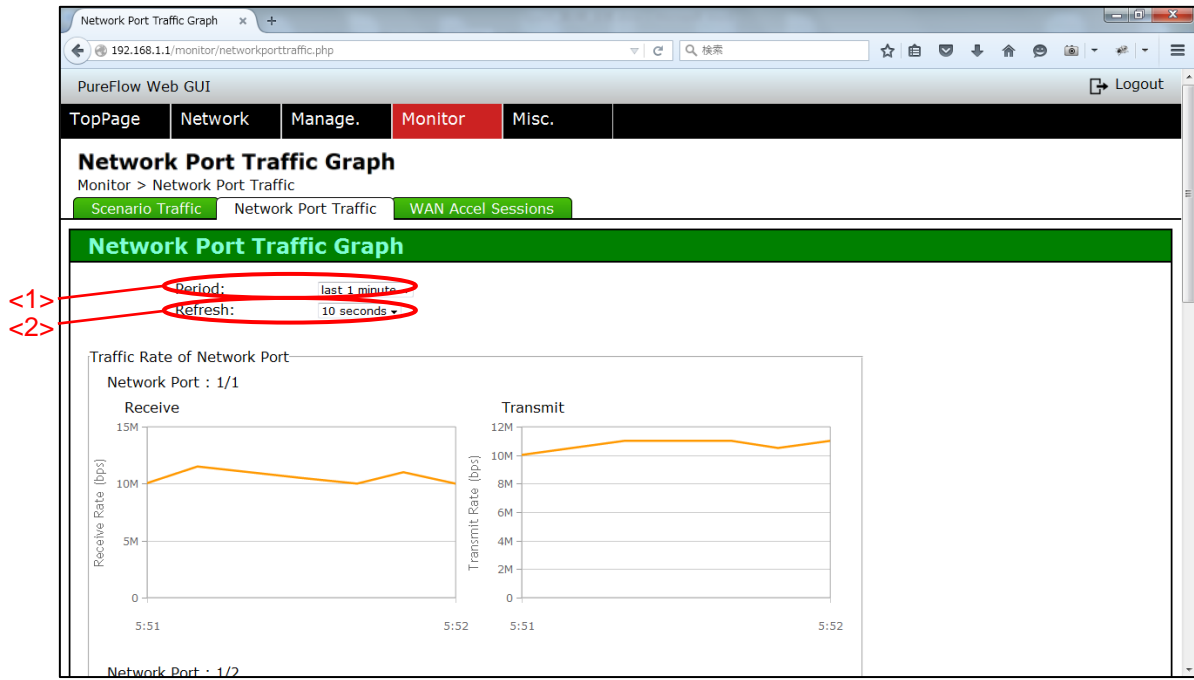

3

Operation Method

3.16 How to Display WAN-accel Sessions Graph

Display the WAN-accel sessions graph.

- * To display the WAN-accel sessions graph, the TCP acceleration function license is required.

Place the mouse cursor on the [Monitor] tab at upper left of the screen. The pull-down menu of the Monitor menu appears. Click the [WAN Accel Sessions] tab.

The WAN accel sessions graph screen appears as show below.

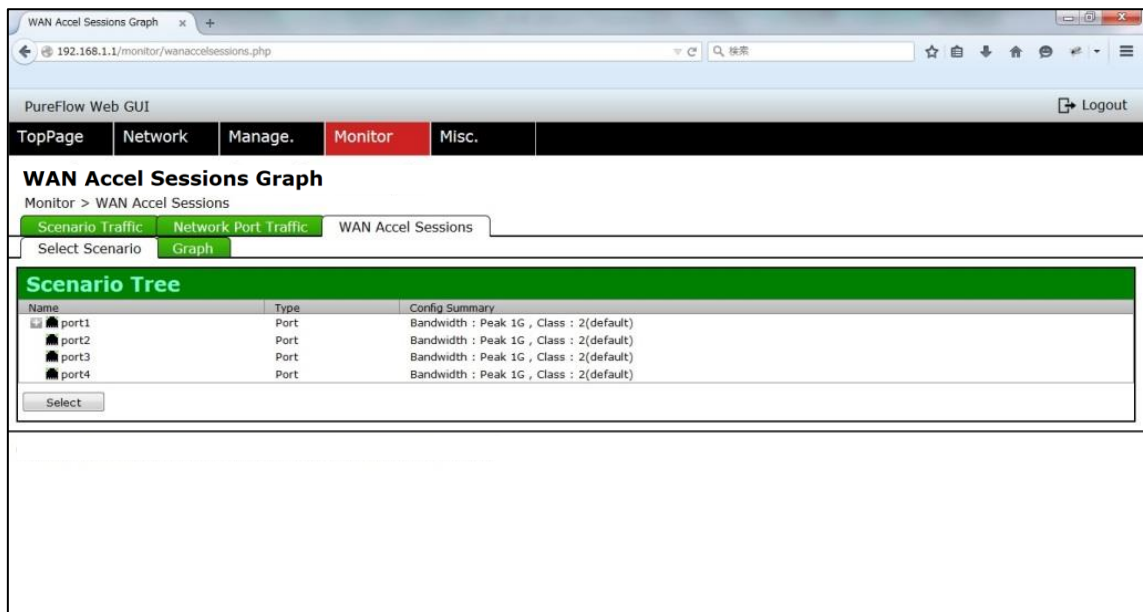

First, select the scenario to display the graph.
Click the [Select Scenario] tab of the "WAN Accel Sessions" window.
The scenario selection screen appears as show below.

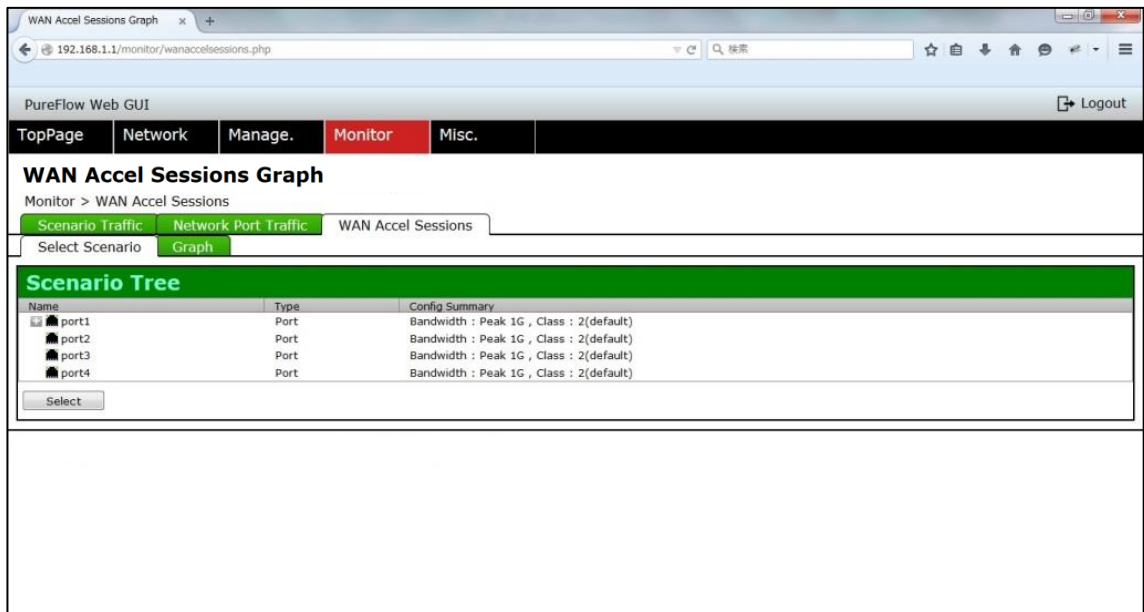

As an example, procedure for selecting a scenario on the 2nd layer for port1 is described below.

<1> Select "port1" in the "Scenario Tree" window, and click the [+] button in gray displays the scenarios on the 2nd layers.

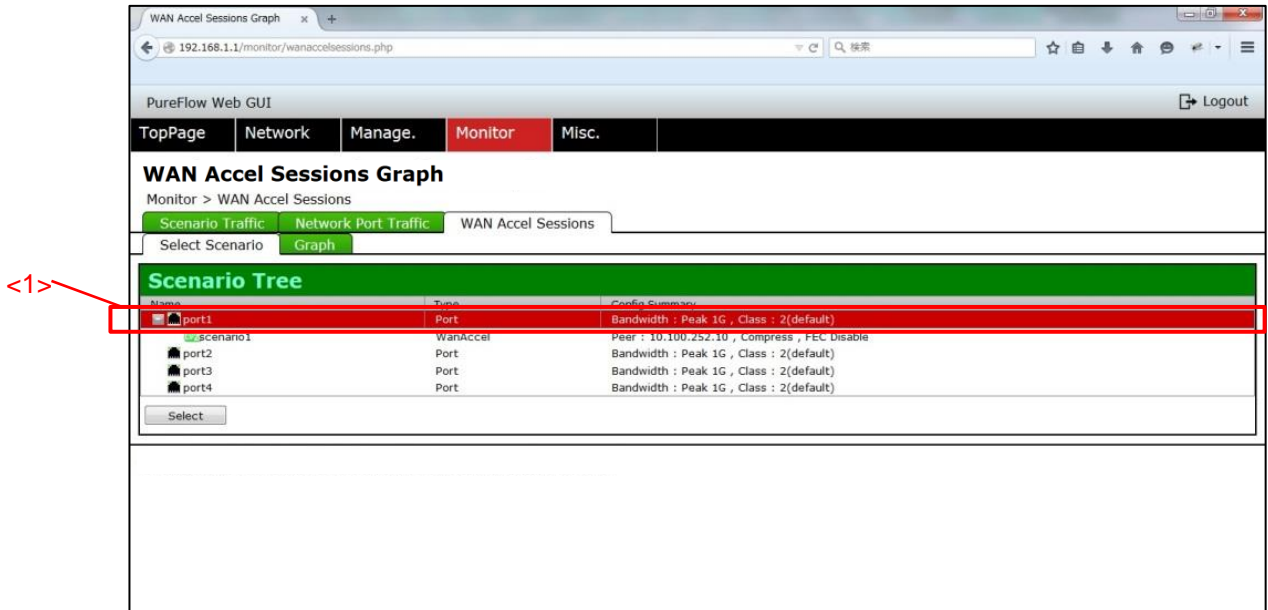

<2> select the relevant scenario, and <3> click the [Select] button.

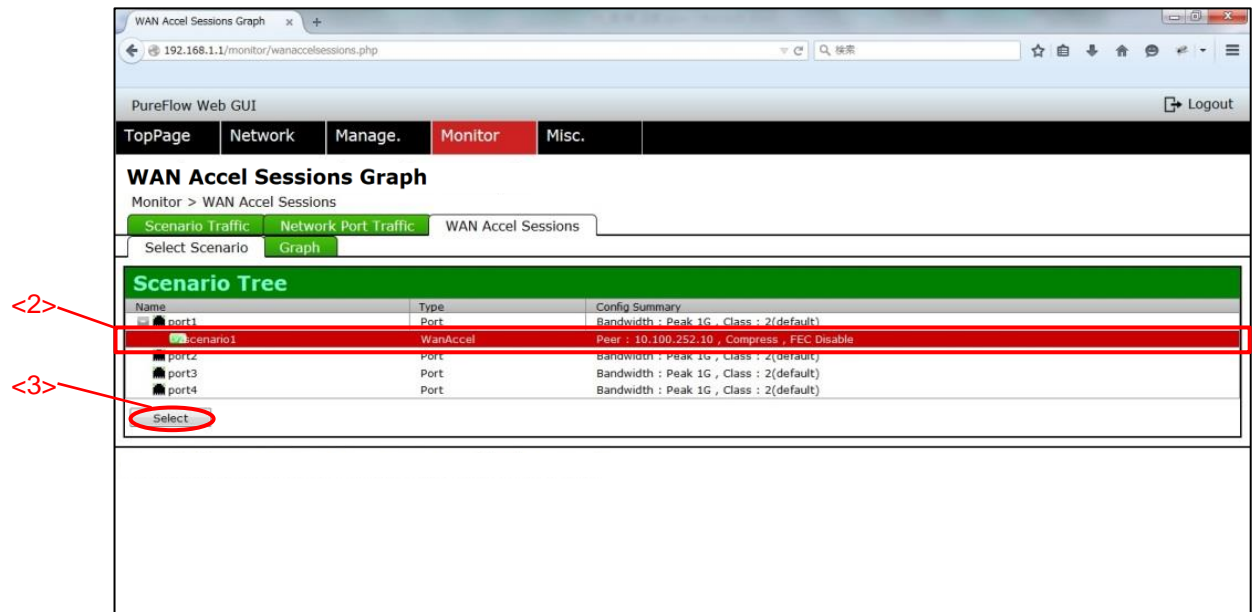

Click the [Graph] tab of the "WAN Accel Sessions" window.
The WAN-accel sessions graph appears as shown below.

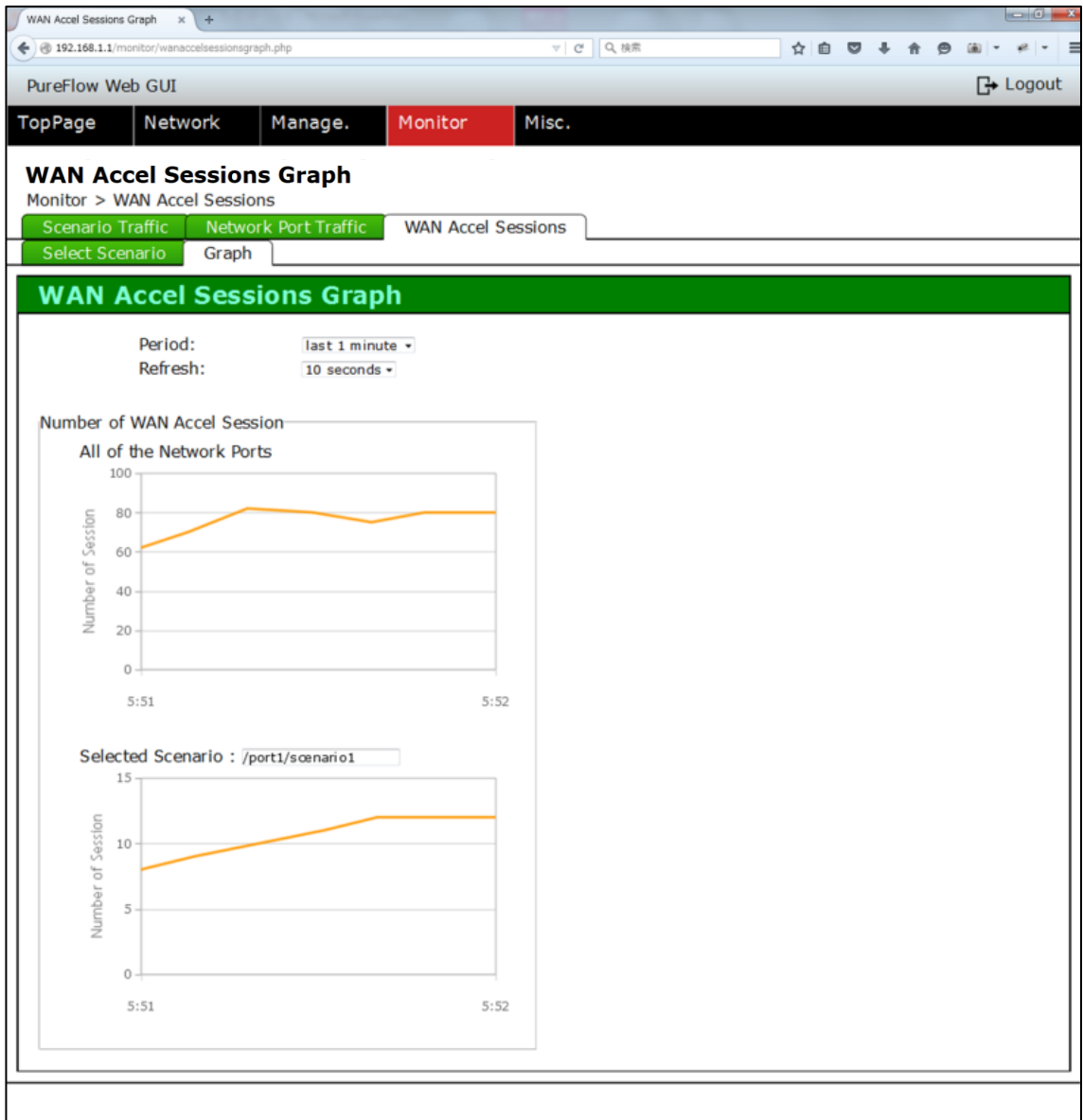

Check that the scenario has been changed as shown below.

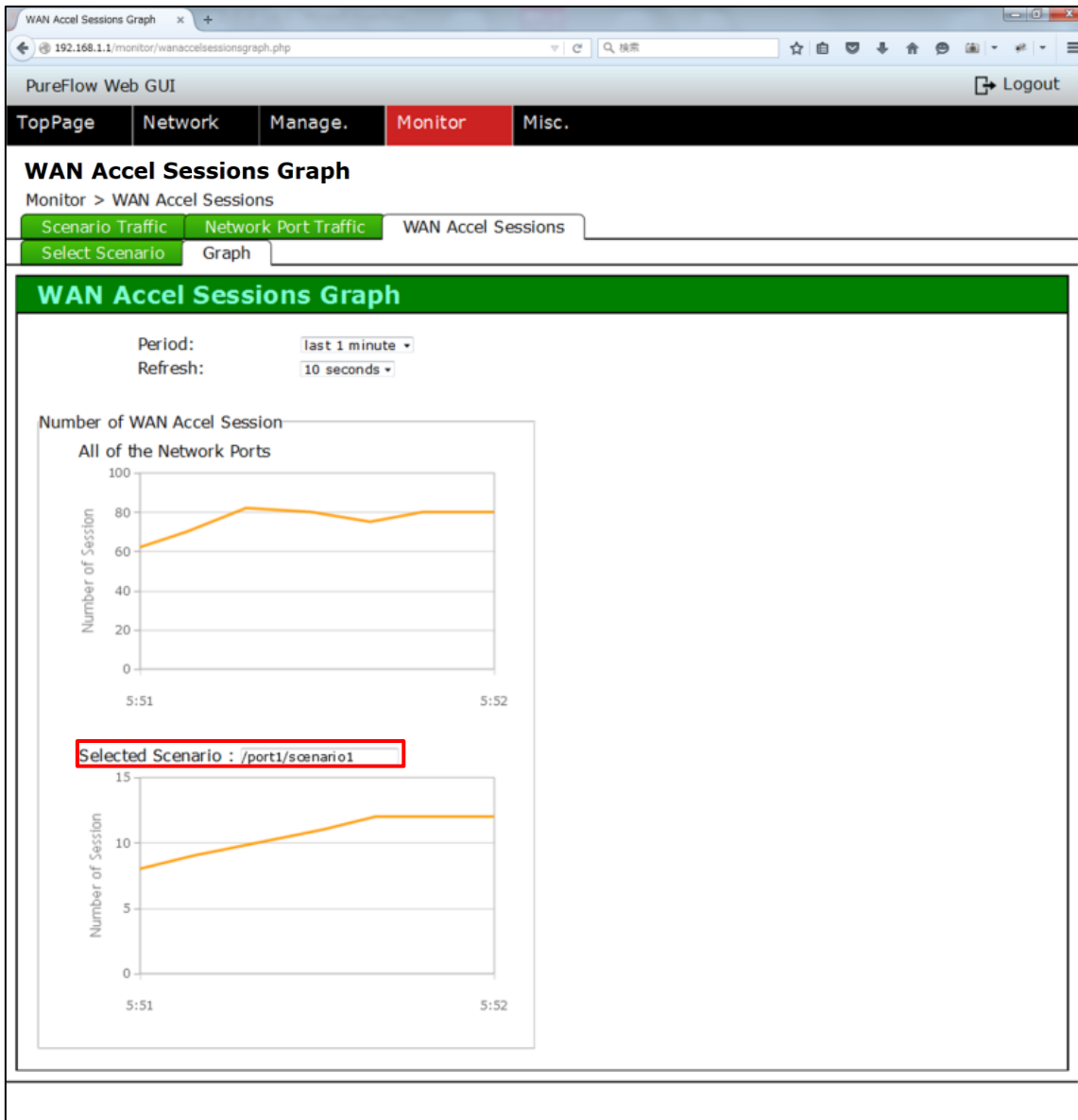

- <4> Range of the graph can be changed in “Period”.
- <5> Period of the graph can be changed in “Refresh”.

The screenshot shows the 'WAN Accel Sessions Graph' page in the PureFlow Web GUI. The page has a navigation bar with 'TopPage', 'Network', 'Manage.', 'Monitor', and 'Misc.' tabs. Below the navigation bar, there are tabs for 'Scenario Traffic', 'Network Port Traffic', and 'WAN Accel Sessions'. Under 'WAN Accel Sessions', there are sub-tabs for 'Select Scenario' and 'Graph'. The main content area is titled 'WAN Accel Sessions Graph' and contains two line graphs. The top graph is titled 'All of the Network Ports' and shows the 'Number of WAN Accel Session' on the y-axis (0 to 100) over time (5:51 to 5:52). The bottom graph is titled 'Selected Scenario : /port1/sœnario1' and shows the 'Number of Session' on the y-axis (0 to 15) over time (5:51 to 5:52). Above the graphs, there are two dropdown menus: 'Period:' set to 'last 1 minute' and 'Refresh:' set to '10 seconds'. Red circles and arrows point to these dropdown menus, with annotations '<4>' and '<5>' respectively.

3.17 How to Check and Save Configuration

3.17.1 How to check configuration

Display the non-default configuration information.

Place the mouse cursor on the [Misc] tab at upper left of the screen.

The pull-down menu of the Misc menu appears. Click the [Config] tab.

The Configuration screen appears.

Click the [Running non-default] button.

The non-default configuration information appears as show below.

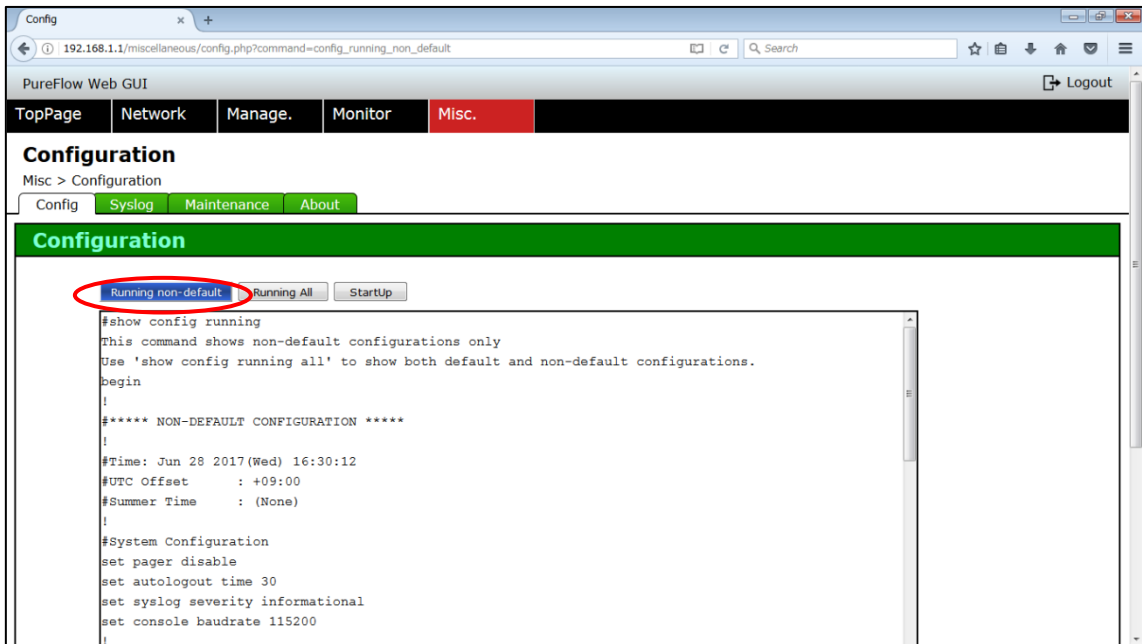

Display the default configuration information and non-default configuration information.

Click the [Running All] button on the Configuration screen.

The default configuration information and non-default configuration information appear as show below.

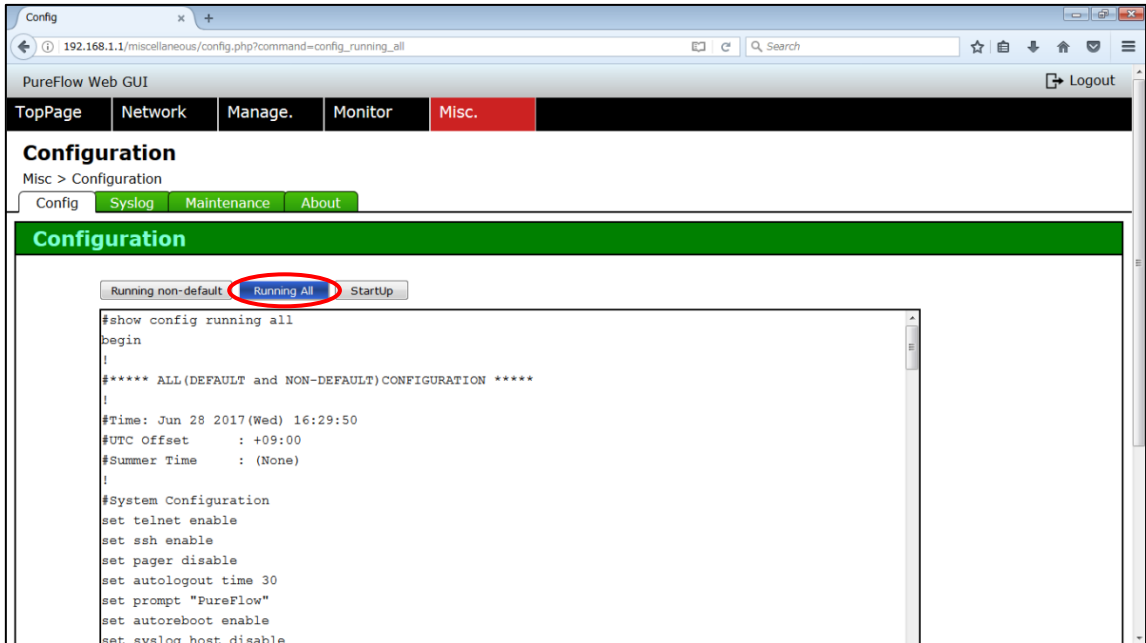

Display the configuration information at startup of the device.
Click the [StartUp] button on the Configuration screen.
The configuration information at startup of the device appears.

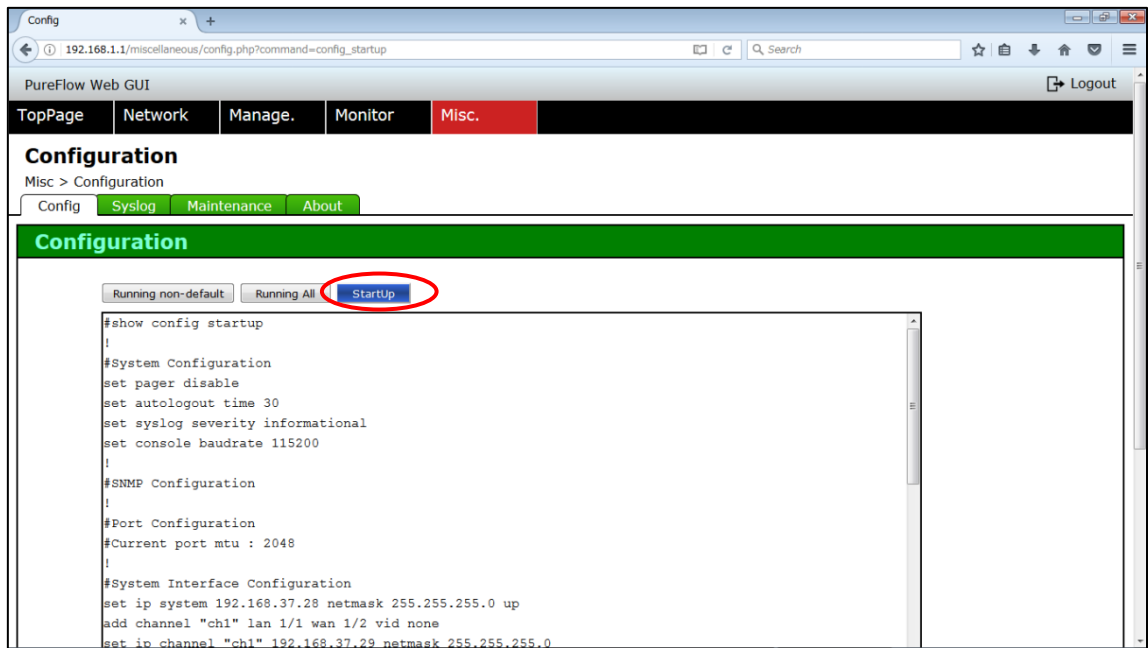

3.17.2 How to save configuration

Save the current configuration information in the internal memory.

Click the [Save Current Configuration] button at the bottom of the Configuration screen.

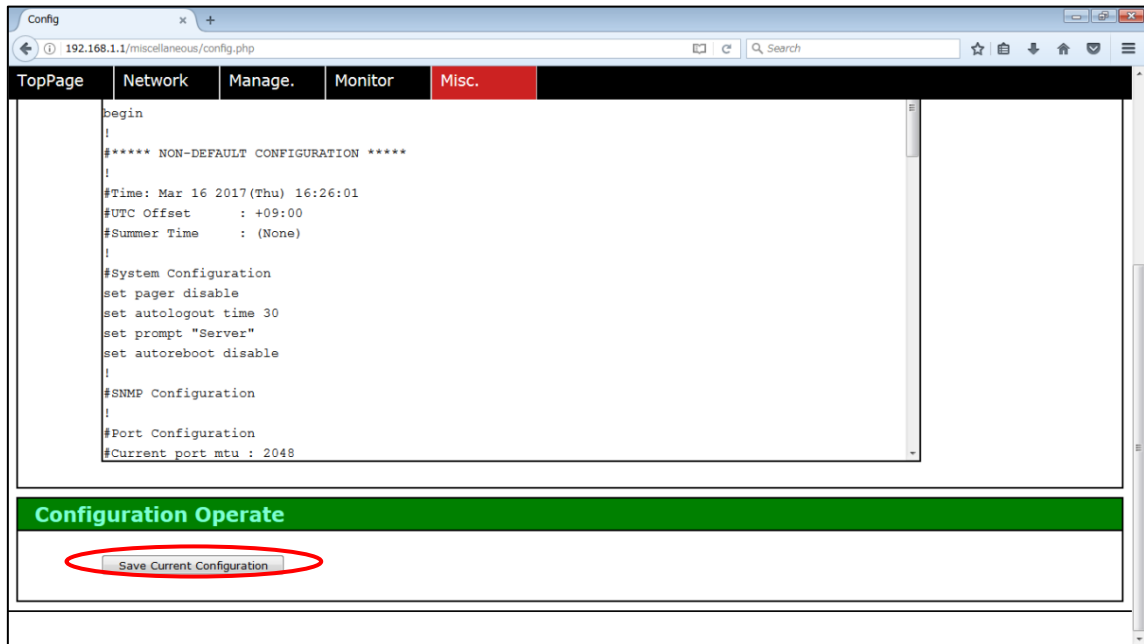

3

Operation Method

Check that the screen that shows the completion of saving appears as shown below.

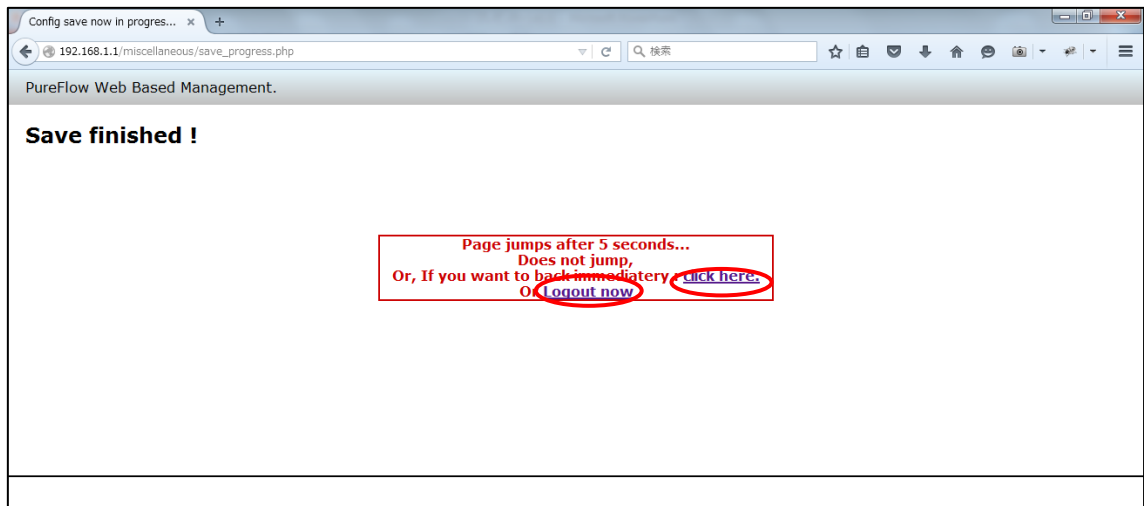

When 5 seconds have elapsed or when clicking [click here], the Configuration screen appears again.

Clicking [Logout now] displays the login screen again.

3.18 How to Check System Log

Display the system log information at the current device operation.

Place the mouse cursor on the [Misc.] tab at upper left of the screen.

The pull-down menu of the Misc. menu appears. Click the [Syslog] tab.

The View Syslog screen appears.

Click the [Current] button.

The system log information at the current device operation appears as shown below.

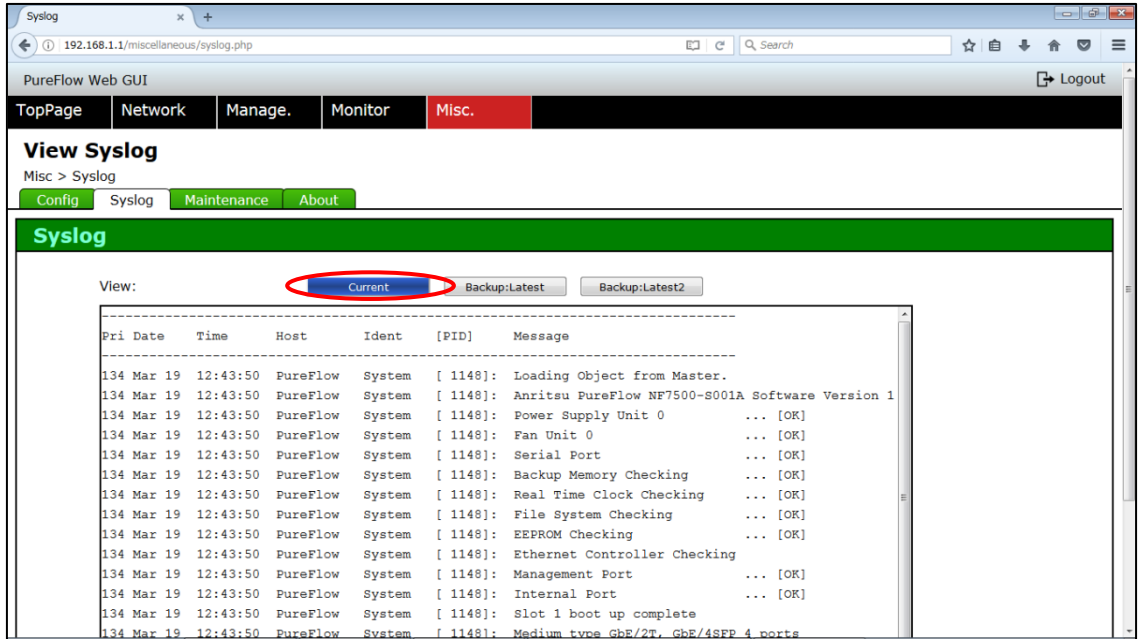

Display the system log information at the latest device operation.
Click the [Backup:Latest] button.

The system log information at the latest device operation appears as shown below.

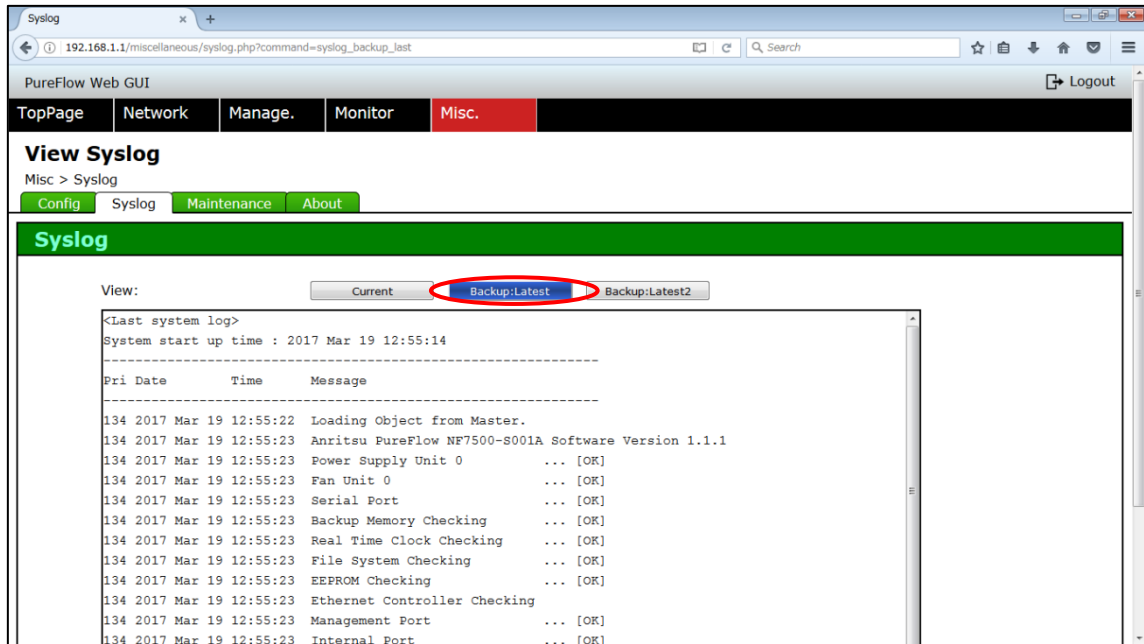

3

Operation Method

Display the system log information at the last-but-one device operation.
Click the [Backup:Latest2] button.

The system log information at the last-but-one device operation appears as shown below.

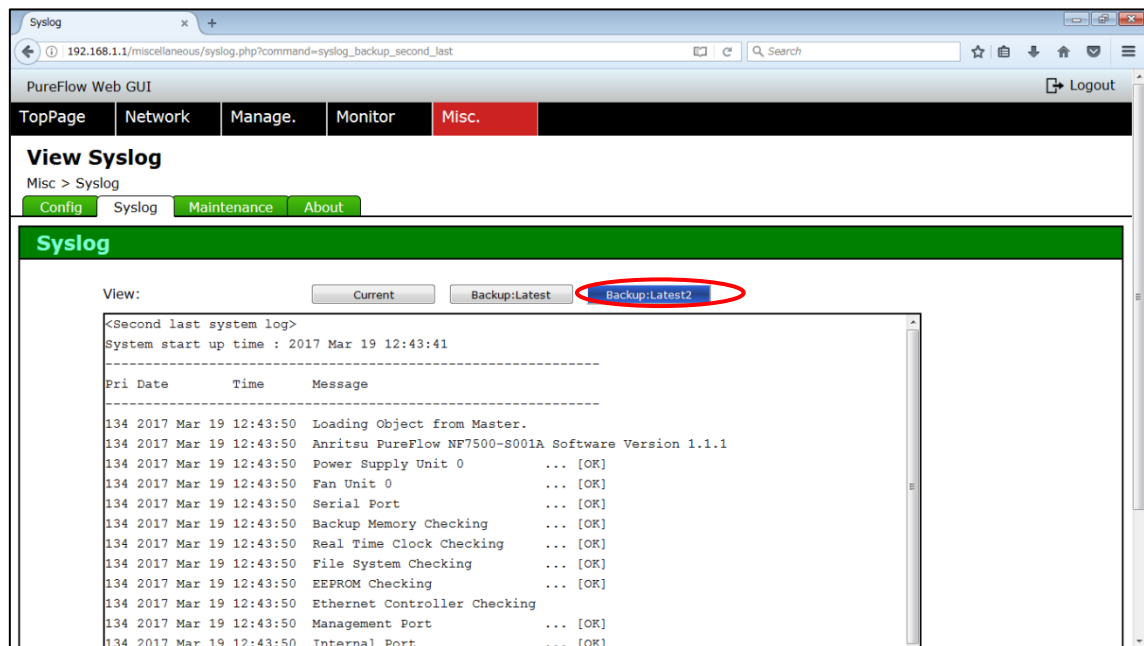

3.19 How to Check Module Information

Check the module information of this device.
Place the mouse cursor on the [Misc.] tab at upper left of the screen.
The pull-down menu of the Misc. menu appears. Click the [About] tab.
The module information appears as shown below.

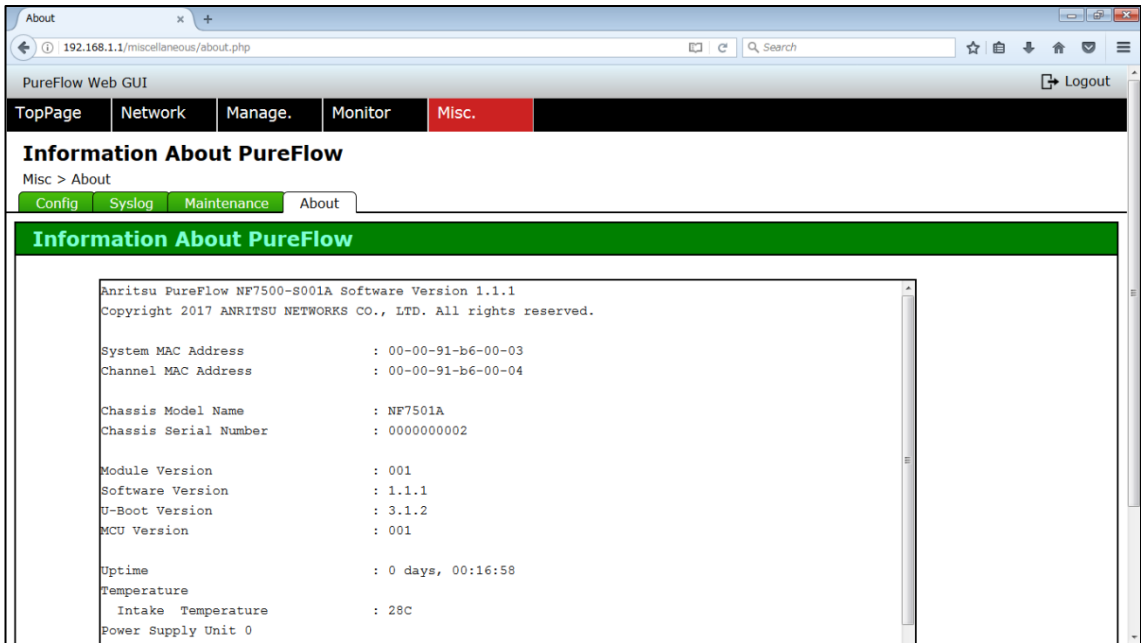

3.20 How to Perform Maintenance Operations

Perform maintenance operations on this device.

Place the mouse cursor on the [Misc.] tab on the upper left of the screen.

The pull-down menu of the Misc. menu appears. Click the [Maintenance] tab.

The Maintenance screen appears as shown below.

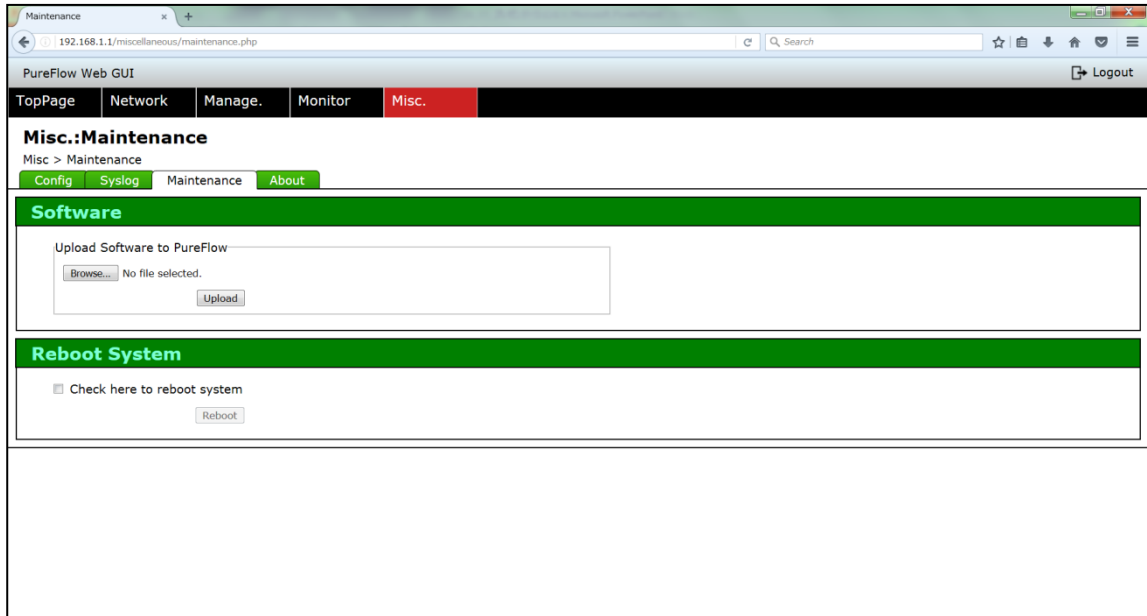

3.20.1 How to upload software

Upload new software (file name: nf7500.bin) to the device.

Click the [Browse] button in the [Software] window. A file selection window will open.

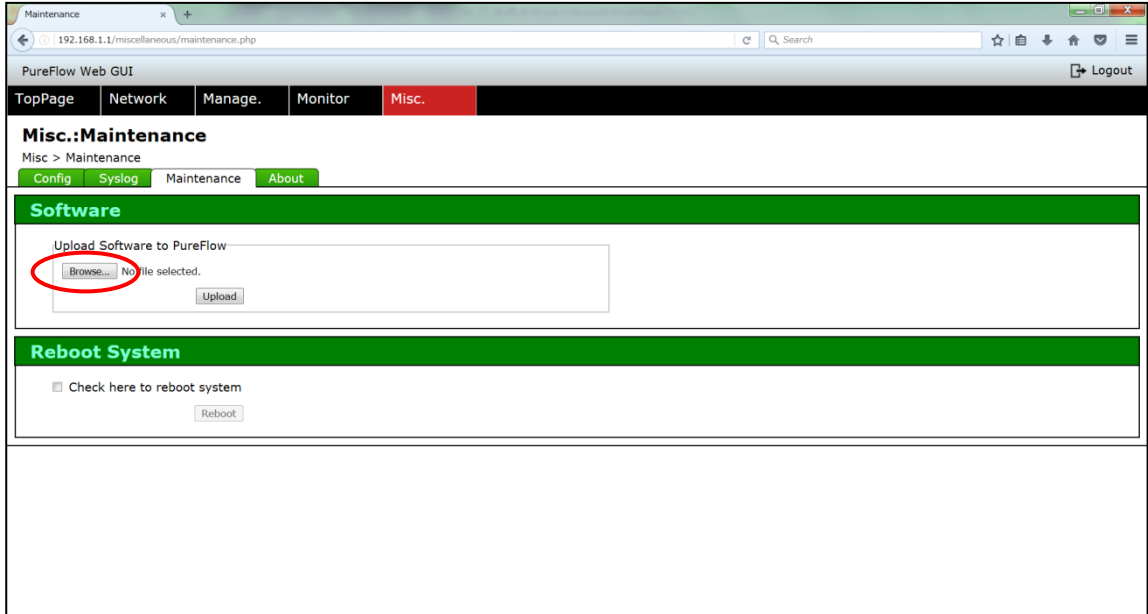

When a file is selected, the file name appears on the right of the [Browse] button.

Click the [Upload] button. The software will start being transferred to the device.

- * Do not perform an operation that moves you to another page while the software is being transferred. If you move to another page, you will need to upload the software again.

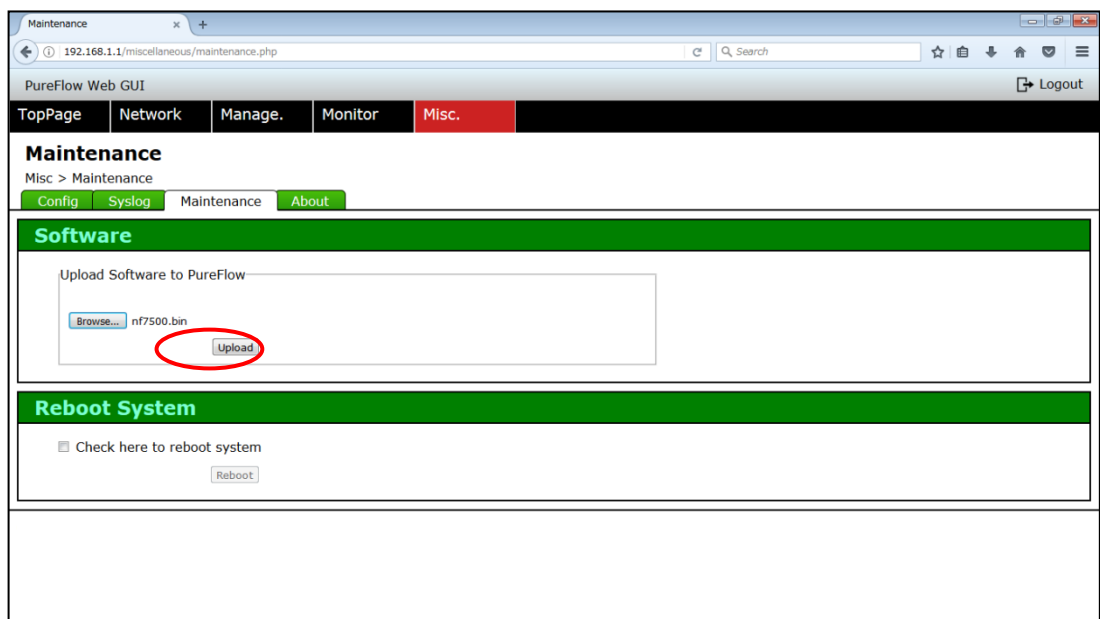

When transfer is complete, the following screen appears showing that the software is being uploaded.

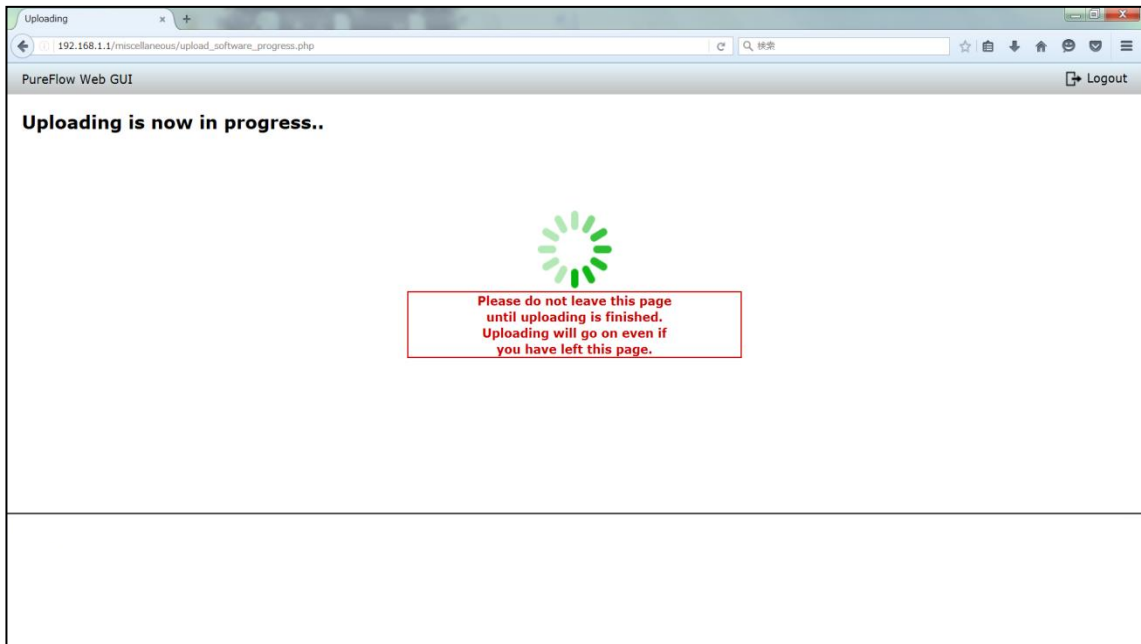

3

Operation Method

Do not allow the power to the device to be turned off while upgrading is in progress.

If the power to the device is inadvertently turned off during the upgrade process, the previous software version saved in a separate area will be reloaded. In this case, reboot the device and upload the new software again.

When uploading is complete, the following message appears.

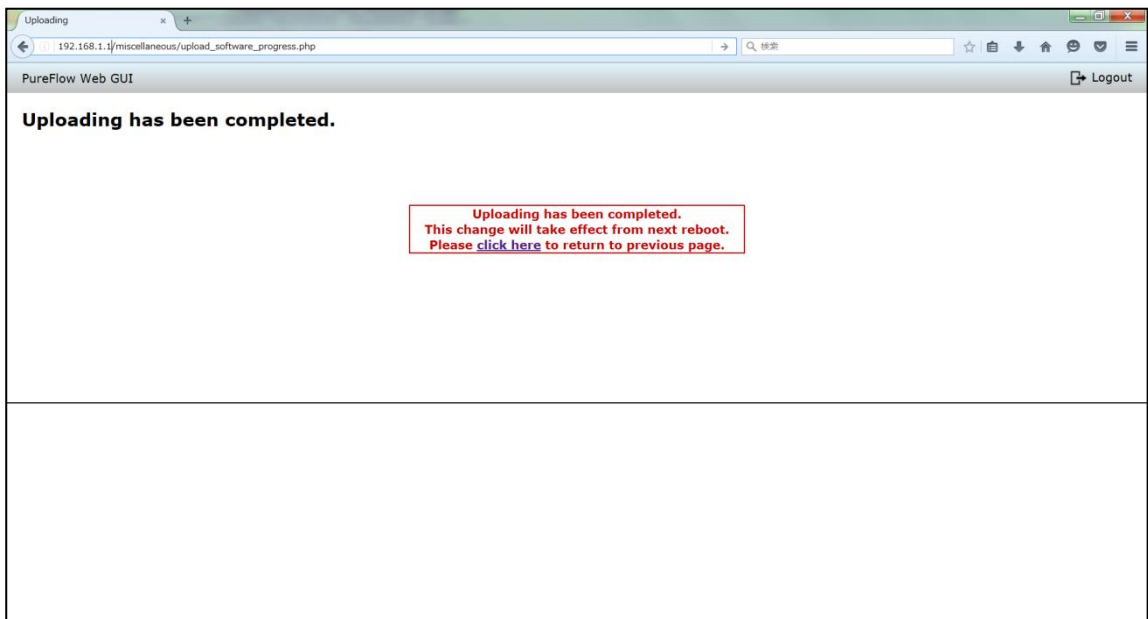

Click [\[click here\]](#) to return to the Maintenance screen.

Even after uploading is complete, the new software will not be immediately applied. Reboot the device to apply the uploaded software.

- * The device will not work if you upload software other than the genuine object file specified by Anritsu (file name: nf7500.bin). Before clicking the [Upload] button in the above procedure, make sure that the file is the genuine object file. If you have uploaded an incorrect file by accident, insert an SD card or USB drive containing the genuine object file, start the device, and download the genuine object file onto the device again.

To obtain the genuine object file, contact the distributor where you purchased your device.

3.20.2 How to reboot the device

Reboot the device.

Selecting the check box in the Reboot System window enables the [Reboot] button.

Click the [Reboot] button to reboot the device.

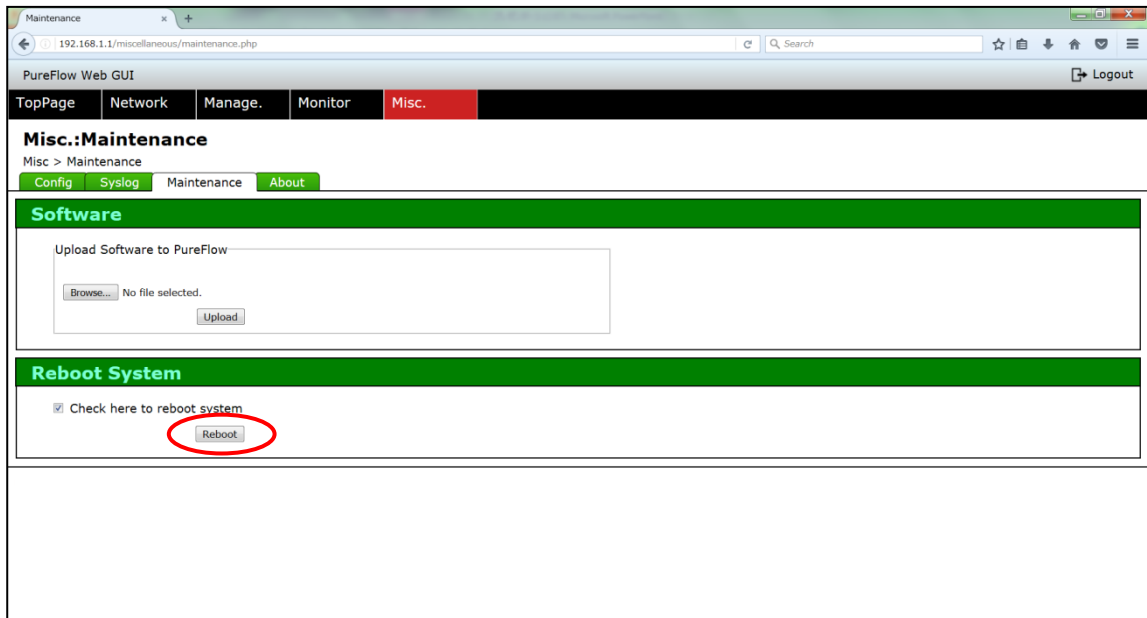

3

Operation Method

The following screen appears showing that the device is being rebooted.

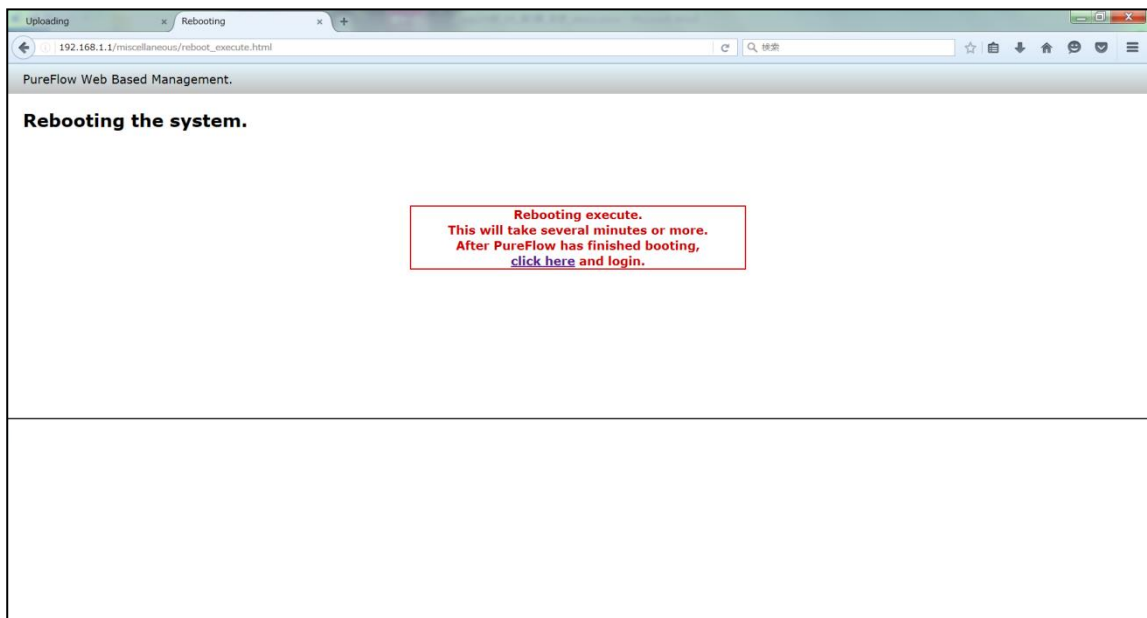

After the device is rebooted, open the Web browser and specify the IP address configured for the system interface. Once communication with the system is established, the login screen will open.

Anritsu

ANRITSU CORPORATION

Document No.:
NF7500-W014E.
Printed in Japan