



# Network Master Pro MT1000A

10G Multirate Module MU100010A

100G Multirate Module MU100011A

High Performance GNSS Disciplined Oscillator MU100090B

Scenario Environment Editing Kit (SEEK) MX100003A

# Contents

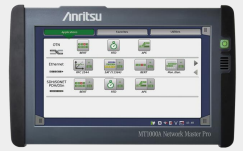

- [Network Master Pro MT1000A](#)
  - [Redefining Transport Testing](#)
- [Instrument Views](#)
- [Product Structure](#)
- [Carrier Class Ethernet Installation and Troubleshooting](#) 
- [TCP Throughput Option \(RFC 6349\)](#)
- [Ethernet OAM Functionality](#)
- [Mobile Backhaul Installation and Verification](#)
  - [Synchronous Ethernet Test](#)
  - [Phase/Time Synchronization Test](#)
- [Mobile Fronthaul Installation and Verification](#)
  - [CPRI/OBSAI Test](#)
  - [eCPRI/IEEE1914.3 Test](#)
- [Powerful Storage Area Networking \(SAN\) Testing](#)
  - [Fibre Channel Functionality](#)
- [OTN Metro and Core Network Installation and Maintenance](#)
- [Quick and Easy Tests of SDH/SONET/PDH/DSn Networks](#)
- [VIP : Video Inspection Probe](#)
- [Operation and Presentation](#)
- [Report Generation](#)
- [Remote Operation](#)
  - [Remote Control - Scripting](#)
  - [Remote GUI & Scripting](#)
- [Automation Testing \(MX100003A\)](#)

# Network Master Pro MT1000A

- Redefining Transport Testing

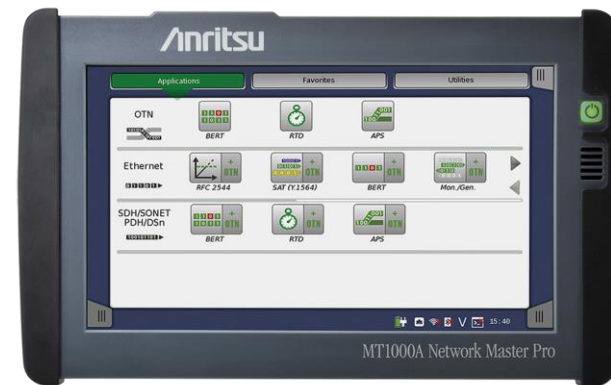

# Market Situation—Historical

- Core network had multiple metro/access network subsets
  - Much of the network coming to the access network was muxed up to a larger metro network which was muxed up to the core network.
    - Not all traffic was transferred to the core, but a large percentage was.
    - To a large extent, the core was the size of the combined metro networks.

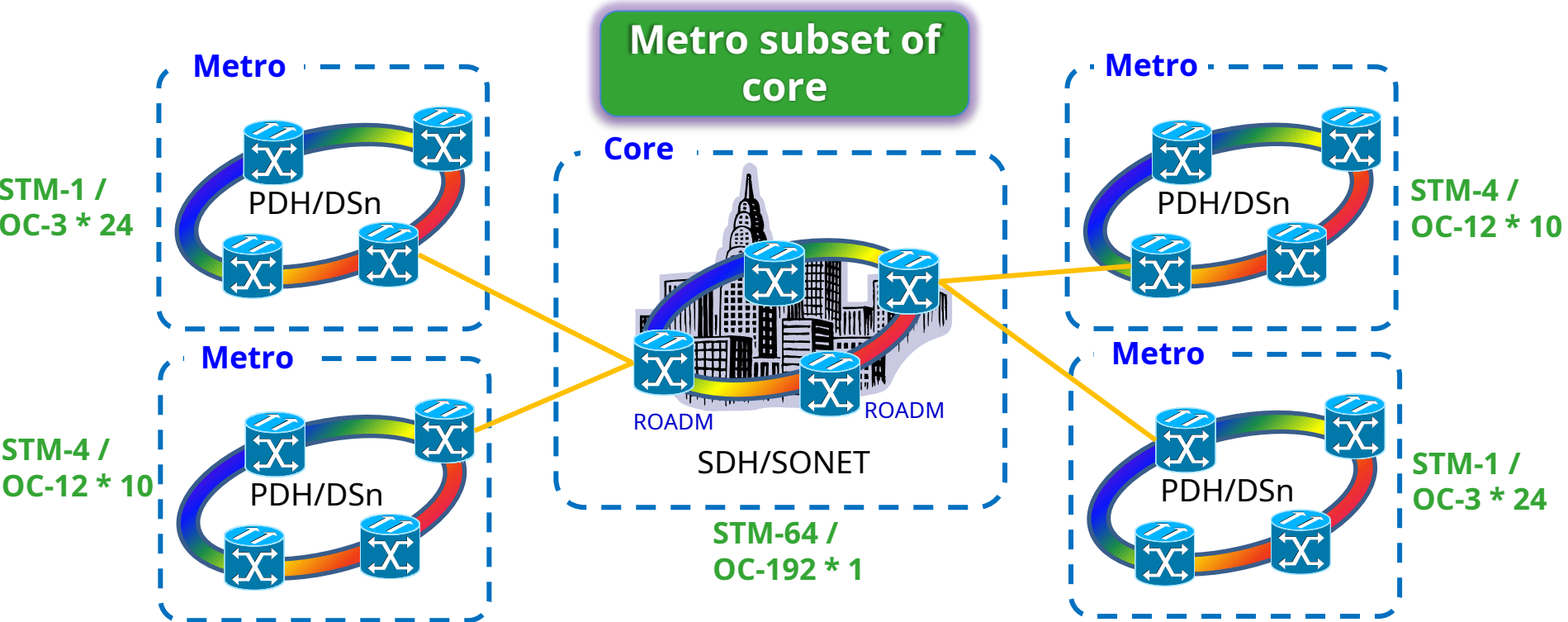



# Market Situation—Current and Future

- Metro networks becoming same or larger size than core
  - Many services now require “near” real-time response (simultaneous multiple access to data)
    - Transferring data long distances to server not ideal
  - Many services to many millions of users (apps) now truly global (apps)
    - A single or even two servers (back-up) isn’t good enough to handle data
  - Many services require very large data from millions of users (video)
    - HD and even UHD video now being streamed

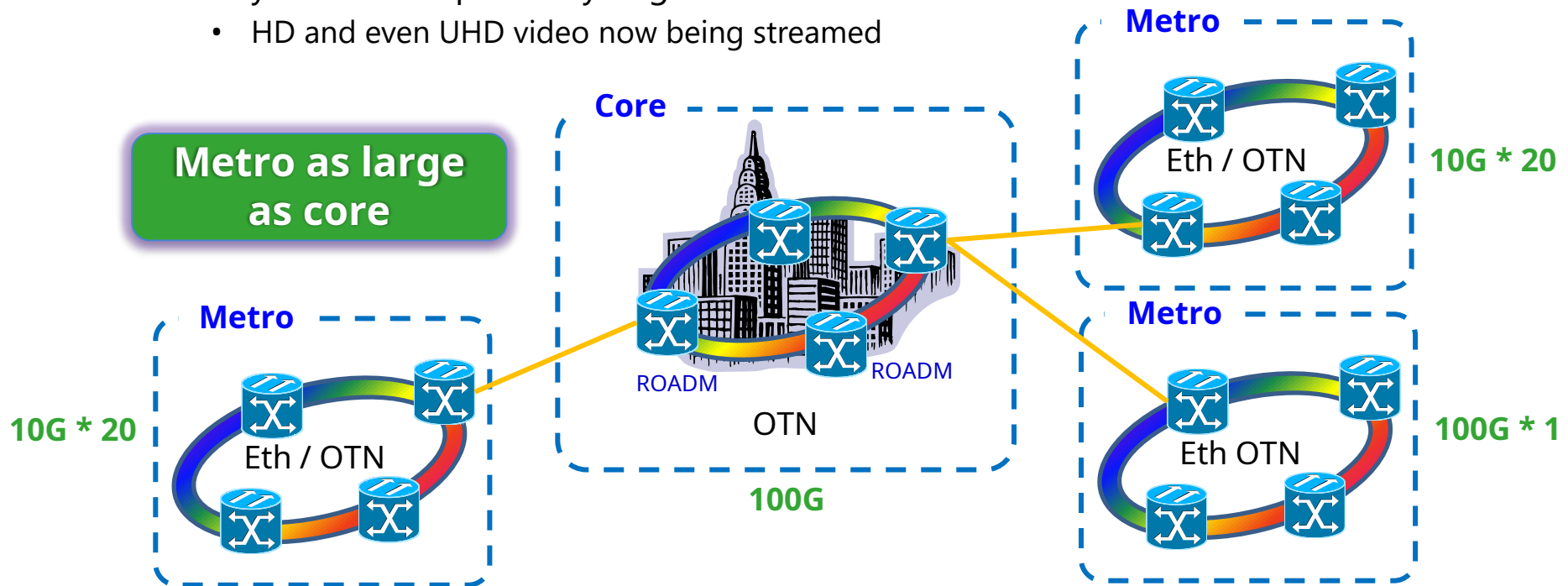

# Market Segmentation

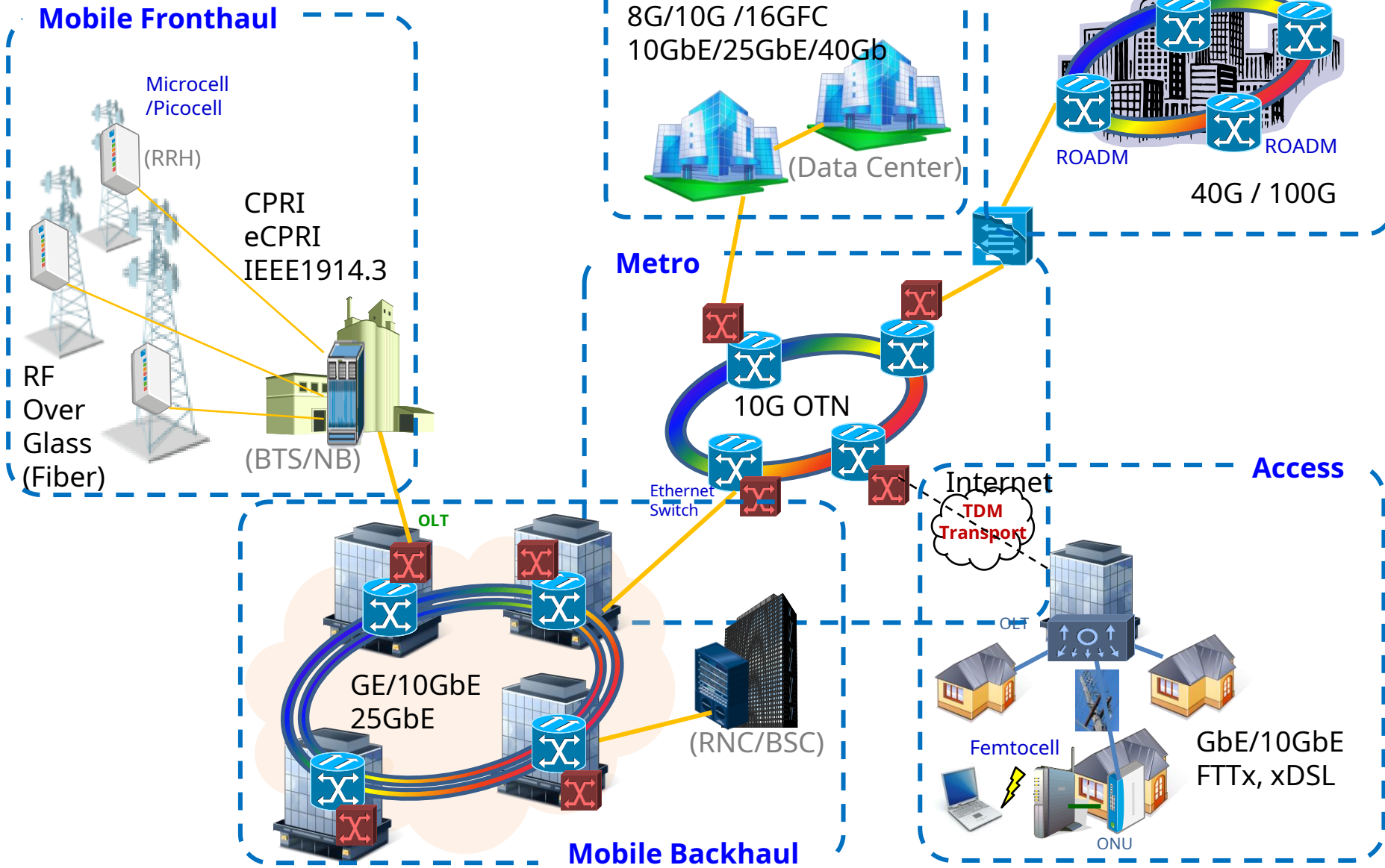

# Where to use MT1000A

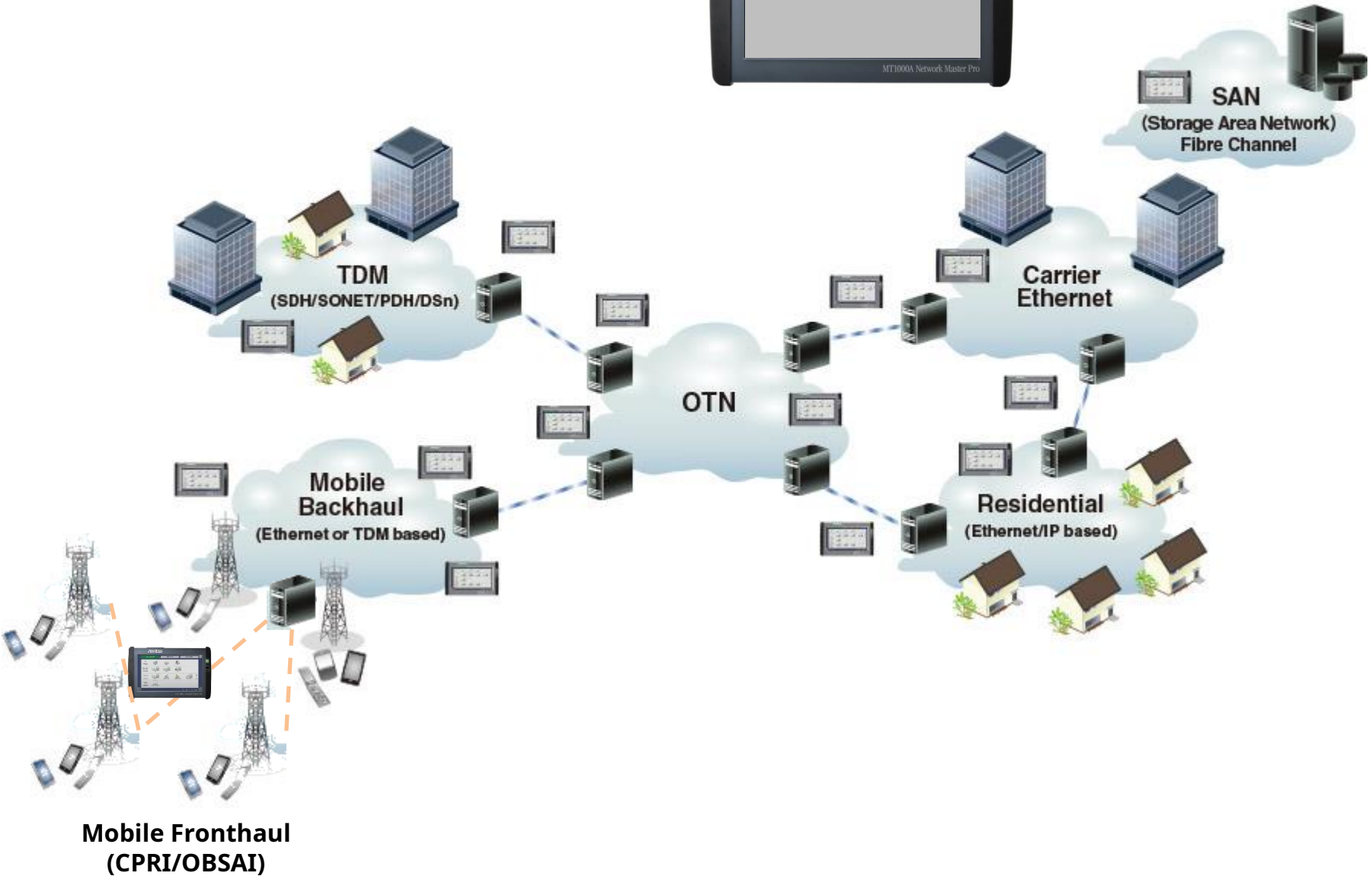
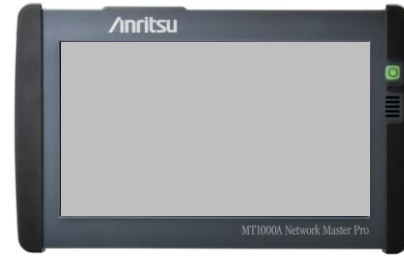

**Mobile Fronthaul  
(CPRI/OBSAI)**

# Out-of-Service Installation Testing

- Installing and commissioning new lines
  - Verify new-line quality/performance before service commissioning
- Troubleshooting with test traffic
  - Test network functions under different loads
- Testing line quality
  - Perform far-end loopback tests using cable or special configuration (protocol dependent)

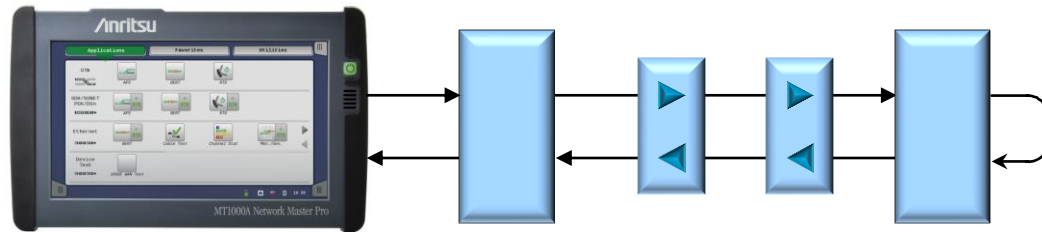

MT1000A

# Out-of-Service Installation Testing

- One-way testing using two instruments
  - Separate results for each line direction
  - Performed between MT1000A and MT1000A

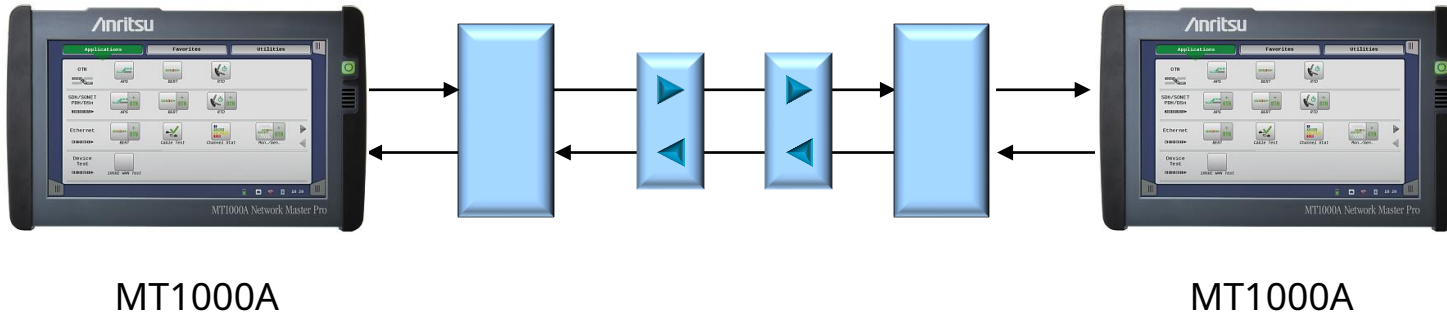

# Out-of-Service Installation Testing

- Efficient simultaneous out-of-service testing of up to two lines
  - Supports up to two fully independent ports at all rates

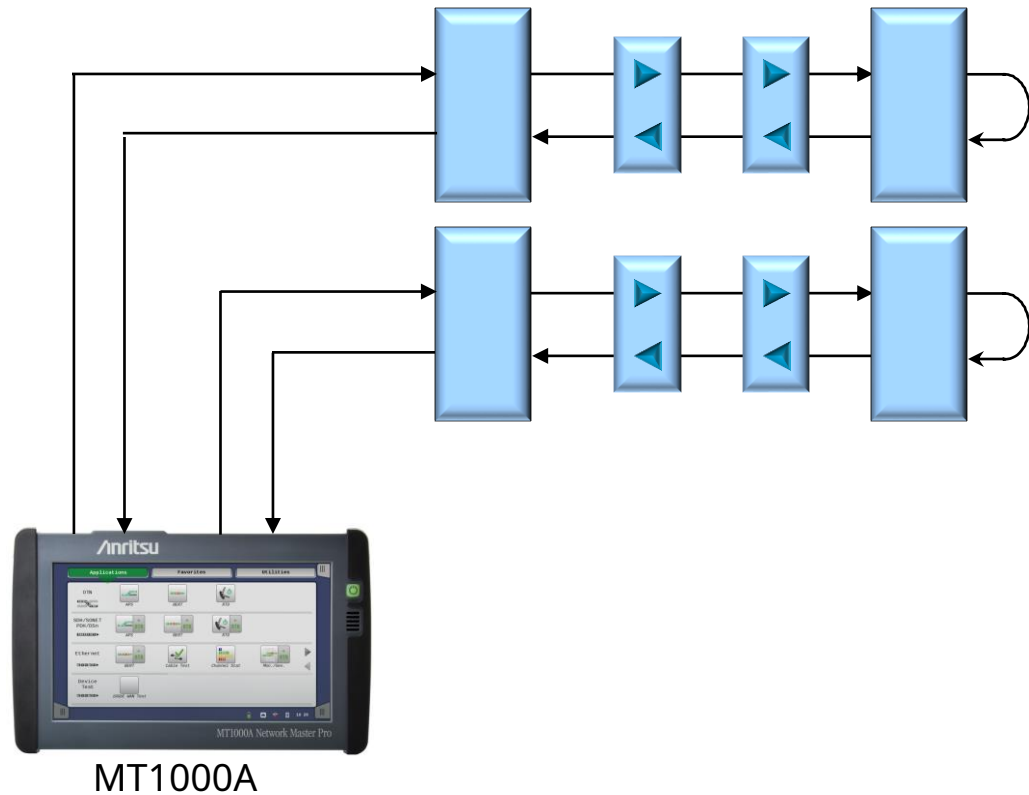

# Out-of-Service Testing

- Network element installation/commissioning
- Error-performance measurements
- Propagation-time measurements
- Alarm, error, slip and frequency-deviation measurements
- System stressing through generation of alarms, errors, slip and frequency offset

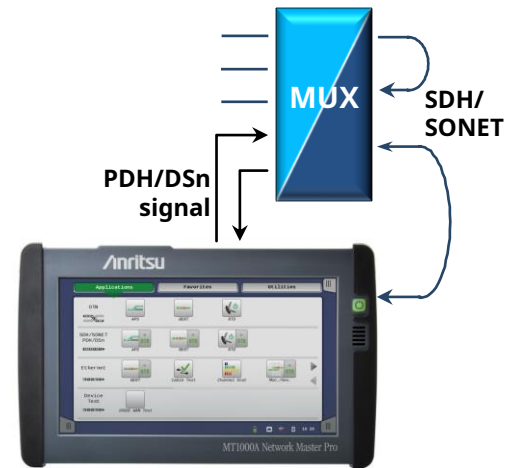
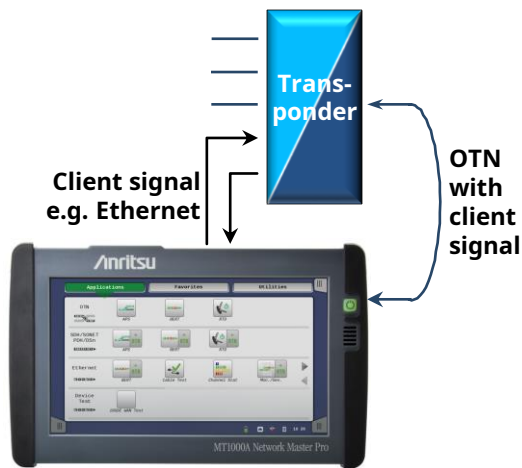

# In-Service Troubleshooting and Analysis

- Monitoring both line directions simultaneously to troubleshoot communications path problems
  - Optimum communications requires smooth data transport in both directions

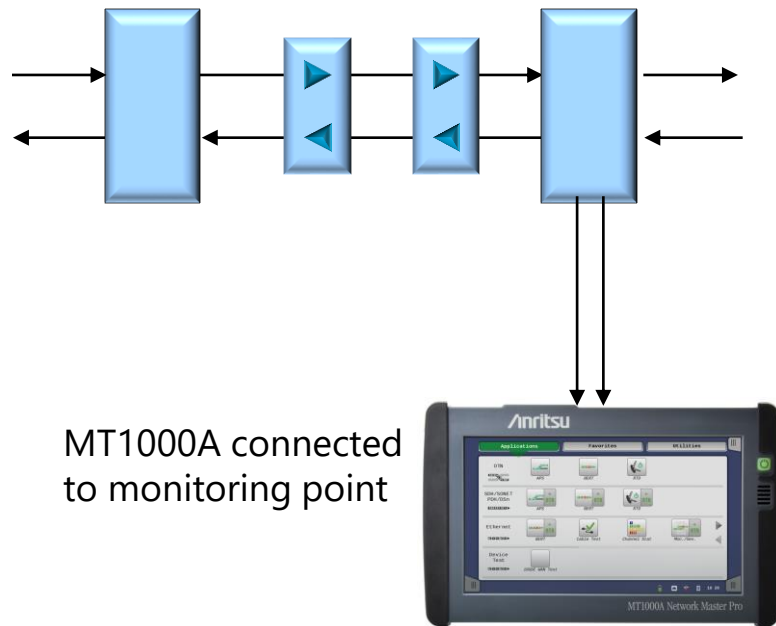

MT1000A connected to monitoring point

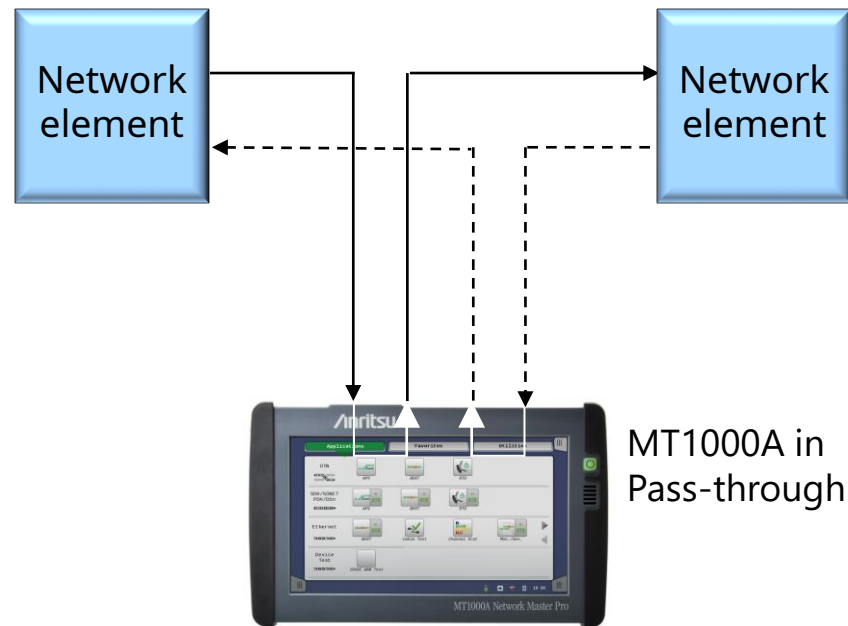

MT1000A in Pass-through mode



# MT1000A Key Applications

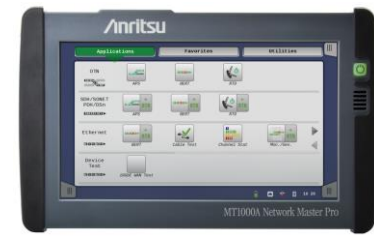

- Carrier Class Ethernet I&M and troubleshooting
  - Ethernet testing up to 100 GigE
  - Include RFC 2544, and Y.1564
  - Include RFC 6349 (Up to 10Gbps)
  - Ethernet OAM
  - MPLS-TP and PBB
  - IP Channel statistics
  - Frame capture for advanced troubleshooting
- Core and Metro networks I&M
  - OTN up to OTU4
  - Mapping of Ethernet/CPRI/SDH/SONET/Fibre Channel client signals, multistage mapping
  - FEC (Forward Error Correction) and O.182 Poisson error insertion
- Mobile Backhaul installation and verification
  - Synchronous Ethernet testing up to 10 GigE (ITU-T G.826x and IEEE 1588 v2)
- Mobile Fronthaul installation and verification
  - CPRI testing up to 10 Gbps
  - OBSAI testing up to 6 Gbps
  - eCPRI/IEEE 1914.3 up to 100 Gbps

# MT1000A Key Applications

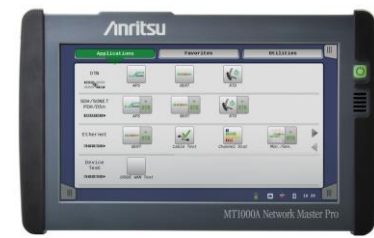

- Powerful Storage Area Networking (SAN) testing
  - Fibre Channel up to 16 Gbps
  - Supports throughput, latency, and buffer credit performance verification
- Quick and easy testing of SDH/SONET, PDH/DSn Networks
  - SDH/SONET up to STM-64/OC-192
  - PDH/DSn (E1, E3, E4, DS1, DS3)
- Fiber endface inspection using VIP (Video Inspection Probe)
- Dual port at 10 Gbps rates
  - Reduced testing time by simultaneous testing of two lines with one unit
  - In-service bi-directional monitoring

# MT1000A Key Benefits and Features



- Easy intuitive GUI
  - Large 9-inch touch screen
  - Eight languages (English, Chinese, Japanese, Korean, German, French, Russian and Spanish)
- WLAN<sup>\*1</sup>/Bluetooth/LAN connectivity
- PDF, CSV and XML report generation for documentation of test results
- Remote operation
  - Using VNC or dedicated GUI operation software
  - Via Ethernet, WLAN
- Remote control (scripting) via Ethernet, WLAN, GPIB
- Hand-held product
  - Compact and lightweight design for maximum portability in field
  - Clam shell (single module installation)
  - Modular platform ensures maximum return on investment
- Battery-operated
- High performance in small form factor

<sup>\*1</sup> Available for certified countries, including USA, Canada, Japan, all EU countries

# Network Master Family



- Transport



Network Master GigE MT9090A	Network Master Pro MT1000A	Network Master Flex MT1100A
Dedicated field test solution for installation and troubleshooting Ethernet links in access network	All-in-one transport tester supporting from 1.5 Mbps to 100 Gbps including OTN, Ethernet, PTP, eCPRI/IEEE 1914.3/CPRI/OBSAI, Fibre Channel, SDH/SONET and PDH/DSn	All-in-one, up to 4-port transport tester supporting from 1.5 Mbps to 100 Gbps including OTN, Ethernet, eCPRI/IEEE 1914.3/CPRI/OBSAI, Fibre Channel, SDH/SONET and PDH/DSn

- Optical



Optical Channel Analyzer MT9090A	μOTDR MT9090A
Compact CWDM channel analyzer to verify power levels, drift and channel presence of CWDM networks	Compact OTDR for fully automatic verification of optical networks, FTTH PON, metro and core

# Network Master Pro MT1000A

- Instrument Views

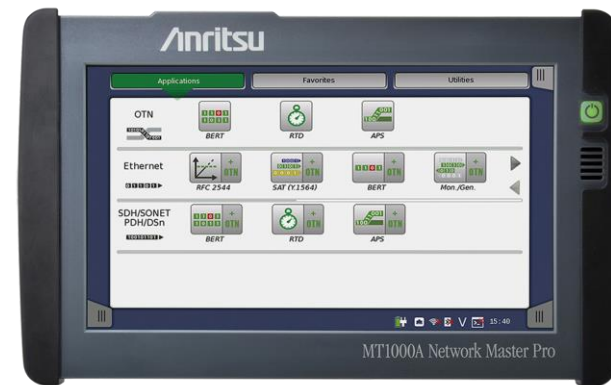

# MT1000A Instrument Views

- Front View



	Kg	lb
Weight	2,7	6,0
	mm	inch
Width	257	10,1
Height	164	6,5
Depth	77	3,0

- Other Views:



# Instrument Views 1/3

- Top (connector panel) View
  - MT1000A + MU100010A

1. Port 1, Tx Bantam (DS1)
2. Port 1, Tx BNC (E1, E3, E4, DS3, STM-1-e, STS-3e)
3. Port 1, Rx Bantam (DS1)
4. Port 1, Rx BNC (E1, E3, E4, DS3, STM-1-e, STS-3e)
5. Port 2, Tx Bantam (DS1)
6. Port 2, Tx BNC (E1, E3, E4, DS3, STM-1-e, STS-3e)
7. Port 2, Rx Bantam (DS1)
8. Port 2, Rx BNC (E1, E3, E4, DS3, STM-1-e, STS-3e)
9. Port 1, Tx/Rx RJ48 (E1 balanced)
10. Port 2, Tx/Rx RJ48 (E1 balanced)
11. Port 1, Tx/Rx SFP/SFP+ (optical OTN/Ethernet/CPRI/OBSAI/Fibre Channel/SDH/SONET)
12. Port 2, Tx/Rx SFP/SFP+ (optical OTN/Ethernet/CPRI/OBSAI/Fibre Channel/SDH/SONET)
13. Port 1, Tx/Rx RJ45 (Ethernet electrical)
14. Port 2, Tx/Rx RJ45 (Ethernet electrical)
15. Audio
16. AUX
17. Clock input
18. USB Mini-B
19. USB A
20. USB A
21. Ethernet service interface
22. DC input (18 VDC)



# Instrument Views 2/3

- Top (connector panel) View
  - MT1000A + MU100011A

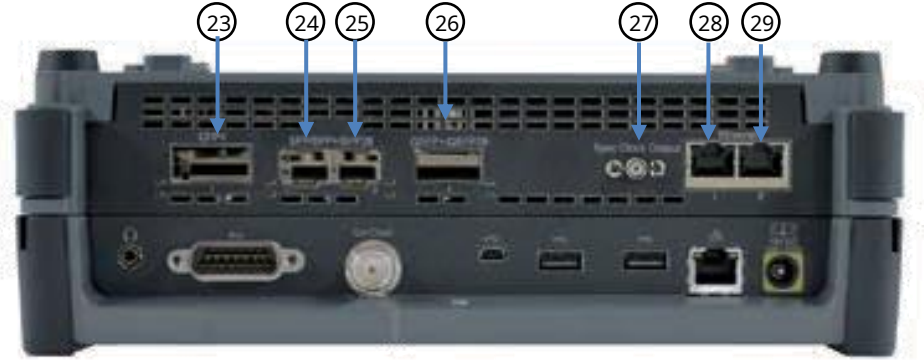

23. Port 1, Tx/Rx CFP4 (optical OTN/Ethernet)
24. Port 1, Tx/Rx SFP/SFP+/SFP28 (optical OTN/Ethernet/eCPRI/RoE/CPRI/OBSAI/Fibre Channel/SDH/SONET)
25. Port 2, Tx/Rx SFP/SFP+/SFP28 (optical OTN/Ethernet/eCPRI/RoE/CPRI/OBSAI/Fibre Channel/SDH/SONET)
26. Port 1, Tx/Rx QSFP28 (optical 25G Ethernet)
27. Port 1, Sync Clock Out (CAUI4, 25GAUI, OTL 4.4)
28. Port 1, Tx/Rx RJ45 (Ethernet electrical)
29. Port 2, Tx/Rx RJ45 (Ethernet electrical)



# Instrument Views 3/3

- Top (connector panel) View
  - MT1000A + MU100010A

- 30. AUX D-SUB 9 pin
- 31. 1 pps Output
- 32. 10 MHz Output
- 33. OCS LED
- 34. GPS received LED
- 35. 1 pps Sync In
- 36. GPS Antenna Input



# Network Master Pro MT1000A

- Product Structure

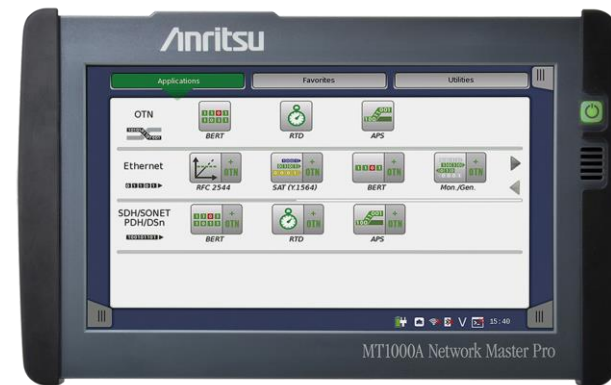

# MT1000A Product Structure

## • Mainframe and Accessories

Model/Order No.	Name
MT1000A	Network Master Pro
<b>Standard Accessories</b>	
MT1000A-006*1	High Power Supply: Installed
	Line Cord*2: 1 pc
B0745A	Softcase: 1 pc
B0728A*3	Rear Panel kit 1 pc
G0385A*4	High Power AC Adaptor: 1 pc
G0310A	Li-ion Battery: 1 pc
Z1746A	Stylus: 1 pc
Z1747A*5	Carrying Strap: 1 pc
Z1748A*6	Handle: 1 pc
Z1817A*7	Utilities ROM: 1 pc
<b>Options</b>	
MT1000A-003*8	Connectivity for WLAN/Bluetooth
MT1000A-005*9	AUX I/O

Model/Order No.	Name
<b>Optional Accessories</b>	
B0691B*10	Hard Case
B0720A	Rear Panel
B0729A*11	Screw 1U
B0730A*11	Screw 2U
B0731A*11	Screw 3U
B0732A*12	Screw Kit
G0382A*13	Autofocus Video Inspection Probe
G0306B*13	Video Inspection Probe
G0309A*4	AC Adapter
G0324A	Battery Charger
G0325A	GPS Receiver
J1569B	Car 12 Vdc Adapter
J1667A*14	GPIO-USB Converter
Z1821A*15	Utilities in USB Stick

### Softcase B0745A (Standard Accessory)

This bag with shoulder strap can hold the MT1000A with up to three installed modules.



### Hard Case B0691B

This strong plastic case can hold the MT1000A with up to two installed modules. 462 (W) × 372 (H) × 207 (D) mm



\*1: The presence of the MT1000A-006 option can be recognized at the top right of the front panel. To retrofit to the already shipped item, please contact us.



Without MT1000A-006      With in MT1000A-006

- \*2: One line cord is attached to the area to shipment.
- \*3: Composed of B0720A, B0729A, B0730A and B0731A. Refer to Module Composition for the module combination.
- \*4: The MT1000A with MT1000A-006 can be used. Use the AC adapter when using the MT1000A without MT1000A-006 installed.
- \*5: Shoulder strap for MT1000A.

- \*6: Hand strap for MT1000A.
- \*7: This DVD includes PDF files and formatting tools of each product's instruction manual (such as W3933AE, W3810AE, W3736AE, W3946AE).
- \*8: Available for certified countries and regions including USA, Canada, Japan and EU countries. Please visit the Anritsu web site for updated information.
- \*9: MT1000A-005 is required for MU100090A. To retrofit to the already shipped item, please contact us.
- \*10: Can use module 1 to 2 in combination
- \*11: Includes 4 bolts of same length
- \*12: Includes B0729A, B0730A and B0731A

\*13: This fiberscope uses the VIP function in the MT1000A Utility menu. Different tip types are used by the G0382A and G0306B.

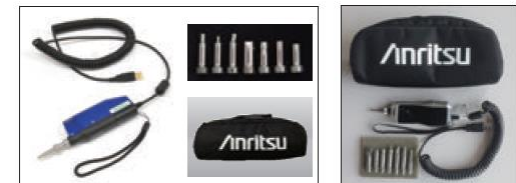

G0382A

G0306B

- \*14: J1667A is required for SCPI remote control via GPIO
- \*15: Include MT1000A Operation Manual and the Remote Script Manual.

# MT1000A Product Structure



## • 10G Multirate Module MU100010A

Model	Name
MU100010A	10G Multirate Module
Standard Accessories	
W3935AE	MT1000A Transport Quick Reference Guide: 1 pc
B0692A*	ESD Box (for optical modules): 1 pc

\*: Up to four SFP+/SFPs can be stored.

MU100010A	Bit Rate	Less than 5G	From 6G to 10G	
Transport Technology	No. of Measurement Ports**	2 (Dual Channel)	1 (Single Channel)	2 (Dual Channel)
<b>Ethernet</b>				
[Pv4/IPv6, Y.1564, IEEE 1588 v2, RFC 2544, BER, Multistream, OAM, SyncE, MPLS, MPLS-TP, Multistage VLAN, PBB, Ping/Traceroute, Cable Tests, In-band Control, Auto discovery, Path-through]		MU100010A-001 Up to 2.7G Dual Channel	MU100010A-011 Ethernet 10G Single Channel	MU100010A-012 Ethernet 10G Dual Channel
TCP Throughput Test (RFC 6349, iPerf)		MU100010A-020 TCP Throughput		
<b>eCPRI/IEEE1914.3 (RoE)</b>				
[Pv4/IPv6, BER, VLAN, SyncE, IEEE 1588 v2, E-OAM]		MU100010A-001 Up to 2.7G Dual Channel	MU100010A-011 Ethernet 10G Single Channel	MU100010A-012 Ethernet 10G Dual Channel
<b>OTN**,*3</b>				
Errors/Alarms, Error Performance/Delay/APS Test, FEC Test, O.182 Test, Overhead Editing/Capture, TCM Monitoring/Generation, Tributary Scan		MU100010A-001 Up to 2.7G Dual Channel	MU100010A-051 OTN 10G Single Channel	MU100010A-052 OTN 10G Dual Channel
ODU Multiplexing Addition**4		MU100010A-061 ODU Multiplexing		
ODU Flex Addition**5		—	MU100010A-062 ODU Flex	
<b>CPRI/OBSAI</b>				
CPRI/OBSAI L1: Level/Bit Rate/Frequency deviation Measurement, Alarms/Errors Detection, Unframed BER CPRI/OBSAI L2: Link Status Monitoring, Alarms/Errors Detection, Framed BER Measurement, RTD Measurement, Monitoring using Passthrough		MU100010A-071 CPRI/OBSAI Up to 5G Dual Channel	MU100010A-072 CPRI/OBSAI 6G to 10G Single Channel	MU100010A-073 CPRI/OBSAI 6G to 10G Dual Channel
<b>Fibre Channel</b>				
Performance Test, Signal Generation/Monitoring, Latency, BER, Line Alarm/Error Monitoring		MU100010A-002 FC 1G 2G 4G Dual Channel	MU100010A-091 FC 8G 10G Single Channel	MU100010A-092 FC 8G 10G Dual Channel
<b>SDH/SONET, PDH/DSn</b>				
PDH/DSn Test, Tw-Way Monitoring/Mapping, Errors/Alarms, Error Performance/Delay/APS Test, Header Monitoring/Generation, Pointer Event Generation, Tributary Scan		MU100010A-001 Up to 2.7G Dual Channel	MU100010A-081 STM-64 OC-192 Single Channel	MU100010A-082 STM-64 OC-192 Dual Channel

Notes:

\*1: The channel is not related to the physical port position. The user can freely choose either of the two physical ports assigned to the option via software. For a dual channel setup, the two different ports of one protocol can operate simultaneously, or two different single channel options can operate simultaneously.

\*2: Please see the datasheet for supported OTN mapping.

\*3: When using the OTN function, the channel can be used as client signal mapped to OTN. For example, when mapping STM-64/OC-192 to OTU2, both the MU100010A-051/052 (for physical port) and the MU100010A-081/082 (for client signal) are required.

\*4: When the ODU Multimapping option is installed, OTN multistage mapping measurements are supported. This one option supports both single channel and dual channel.

\*5: When the ODU Flex option is installed, since transport is over OTN networks, mappings based on used ODU Flex standard can be measured. This one option supports both single channel and dual channel.

# MT1000A Product Structure



Model	Name
MU100011A*	100G Multirate Module
<b>Standard Accessories</b>	
W3935AE	MT1000A Transport Quick Reference Guide: 1 pc

\*: MT1000A-006 is required for MU100011A.

## • 100G Multirate Module MU100011A

MU100011A	Bit Rate	Up to 10G		Higher than 10G
Transport Technology	No. of Measurement Ports**	1 (Single Channel)	2 (Dual Channel)	1 (Single Channel)
<b>Ethernet</b>				
IPv4/IPv6, Y.1564, IEEE 1588 v2, RFC 2544, BER, Multistream, OAM, SyncE, MPLS, MPLS-TP, Multistage VLAN, PBB, Ping/Traceroute, Cable Tests, In-band Control, Auto discovery, Path-through	MU100011A-001 Up to 10G Single Channel	MU100011A-003 Up to 10G Dual Channel	MU100011A-017 Ethernet 25G Single Channel	MU100011A-013 Ethernet 40G Single Channel
TCP Throughput Test (RFC 6349, iPerf)	MU100011A-020	TCP Throughput	MU100011A-015 Ethernet 100G Single Channel	—
Measurement using 100GBASE-SR	—	—	MU100011A-023 RS-FEC for 100GBASE-SR4	MU100011A-015 Ethernet 100G Single Channel
<b>eCPRI/IEEE1914.3 (RoE)</b>				
IPv4/IPv6, BER, VLAN, SyncE, IEEE 1588 v2, E-OAM	MU100011A-001 Up to 10G Single Channel	MU100011A-003 Up to 10G Dual Channel	MU100011A-017 Ethernet 25G Single Channel	MU100011A-013 Ethernet 40G Single Channel
Measurement using 100GBASE-SR	—	—	MU100011A-015 Ethernet 100G Single Channel	MU100011A-023 RS-FEC for 100GBASE-SR4
<b>OTN**1, **2</b>				
Errors/Alarms, Error Performance/Delay/APS Test, FEC Test, O.182 Test, Overhead Editing/Capture, TCM Monitoring/Generation, Tributary Scan	MU100011A-001 Up to 10G Single Channel	MU100011A-003 Up to 10G Dual Channel	MU100011A-053 OTN 40G Single Channel	MU100011A-055 OTN 100G Single Channel
ODU Multiplexing Addition**2, **4 ODU Flex Addition**2, **3	MU100011A-063 ODU Multiplexing/Multi Stage		MU100011A-062 ODU Flex	
<b>CPRI/OBSAI</b>				
CPRI/OBSAI L1: Level/Bit Rate/Frequency deviation Measurement, Alarms/Errors Detection, Unframed BER CPRI/OBSAI L2: Link Status Monitoring, Alarms/Errors Detection, Framed BER Measurement, RTD Measurement, Monitoring using Passthrough	MU100011A-071 CPRI/OBSAI Up to 10G Single Channel	MU100011A-072 CPRI/OBSAI Up to 10G Dual Channel	—	
<b>Fibre Channel</b>				
Performance Test, Signal Generation/Monitoring, Latency, BER, Line Alarm/Error Monitoring	MU100011A-004 Up to 10G FC Single Channel	MU100011A-005 Up to 10G FC Dual Channel	MU100011A-091 FC 16G Single Channel	
<b>SDH/SONET</b>				
PDH/DSn Test, Tw-Way Monitoring/Mapping, Errors/Alarms, Error Performance/Delay/APS Test, Header Monitoring/Generation, Pointer Event Generation, Tributary Scan	MU100011A-001 Up to 10G Single Channel	MU100011A-003 Up to 10G Dual Channel	MU100011A-083** STM-256/OC-768 Client Signal	

### Notes:

- \*1: The channel is not related to the physical port position. The user can freely choose either of the two physical ports assigned to the option via software. For a dual channel setup, the two different ports of one protocol can operate simultaneously, or two different single channel options can operate simultaneously.
- \*2: Please see the datasheet for supported OTN mapping.
- \*3: When using the OTN function, the channel can be used as client signal mapped to OTN. For example, when mapping 100G Ethernet to OTU4, both the MU100011A-055 (for physical port) and the MU100011A-015 (for client signal) are required.
- \*4: When the ODU Multiplexing/Multistage option is installed, OTN multistage mapping measurements are supported. This one option supports both single channel and dual channel.
- \*5: This mapping function is based on the ODUflex standard for transmissions over OTN networks and supports client signals of any speed.
- \*6: The MU100011A has no STM-256/OC-768 PHY interface; it can be used for OTN client signals.

# MT1000A Product Structure

- Optical Transceiver for Transport Module

Model No.	Name	Factor	100 Meg Ethernet	156 Meg STM-1	614 Meg CPRI	622 Meg STM-4	768 Meg OBSAI	1G FC	1.23 Gig CPRI	1.25 Gig Ethernet	1.54 Gig OBSAI	2G FC	2.46 Gig CPRI	2.488 Gig STM-16	2.67 Gig OTU1	3.07 Gig CPRI OBSAI	4G FC	4.92 Gig CPRI	6.14 Gig CPRI OBSAI	8G FC	9.83 Gig CPRI	9.95 Gig STM-64	10.1 Gig CPRI	10.3 Gig Ethernet	10G FC	10.7 Gig OTU2	11.05 Gig OTU1e	11.09 Gig OTU2e	11.27 Gig OTU1T	11.3 Gig OTU2T	16G FC	25G Ethernet	40G Ethernet	40G OTN	100G Ethernet	100G OTN				
✓ G0.322A	100M FX 1310 nm MM SFP	SFP	1310 nm MM 2cm																																					
✓ G0.319A	Up to 2.7G 1310 nm 15 km SFP	SFP								1310 nm SM 15 cm																														
✓ G0.320A	Up to 2.7G 1310 nm 40 km SFP	SFP								1310 nm SM 40 cm																														
✓ G0.321A	Up to 2.7G 1550 nm 80 km SFP	SFP								1550 nm SM 80 cm																														
✓ G0.328A	1G/2G/4G FC 850 nm SFP	SFP								850 nm MM 05 cm																														
✓ G0.322A	1G/2G/4G FC 1310 nm SFP	SFP								1310 nm SM 10 cm																														
✓ G0.323A	1G/2G/4G FC 1550 nm SFP	SFP								1550 nm SM 40 cm																														
✓ G0.315A	10G LR/LW 1310 nm SFP+	SFP+																																						
✓ G0.316A	10G ER/ERW 1550 nm 40 km SFP+	SFP+																																						
✓ G0.318A	10G ZR/ZW 1550 nm 80 km SFP+	SFP+																																						
✓ G0.329A	10G LR 1310 nm SFP+	SFP+								1310 nm SM 10 cm																														
✓ G0.356A	9G FC/10G SR 850 nm SFP+	SFP+																																						
✓ G0.386A	16G FC SR 850 nm SFP+	SFP+																																						
✓ G0.387A	16G FC LR 1310 nm SFP+	SFP+																																						
✓ G0.388A	25G SR 850 nm SFP28	SFP28																																						
✓ G0.389A	25G LR 1310 nm SFP28	SFP28																																						
✓ G0.296A	40G SR4 850 nm QSFP+	QSFP+																																						
✓ G0.334A	40G LR4 1310 nm QSFP+	QSFP+																																						
✓ G0.366A	100G SR4 850 nm QSFP28	QSFP28																																						
✓ G0.364A	100G LR4 1310 nm QSFP28	QSFP28																																						
✓ G0.365A	100G LR4 Dual Rate 1310 nm QSFP28	QSFP28																																						
✓ G0.369A	100G LR4 Dual Rate 1310 nm CFP4	CFP4																																						

# MT1000A Product Structure

- High Performance GNSS Disciplined Oscillator MU100090B



Model/Order No.	Name
MU100090B*1	High Performance GNSS Disciplined Oscillator
MU100090B-001	High Stability/Multi-Band
MU100090B-002	Multi-GNSS
<b>Standard Accessories</b>	
J1705A	AUX Conversion Adaptor
J1886A*2	GNSS Antenna
J1710A	BNC Cable (20 cm) × 2
Z2122A	Tripod for GNSS Antenna

\*1: Excellent Eco Product non-compliant.  
 \*2: With 5 m cable, IP67 Ingress protection.  
 MT1000A-005 is required for MU100090B.

- Transport Test Accessories

Model	Name	Notes
G0325A	GPS Receiver	It is required when measuring one-way latency at Ethernet tests. However, it is unnecessary when purchasing MU100090A.
W3933AE	MT1000A Transport Module Operation Manual	Printed manual
W3736AE	MT1000A/MT1100A Remote Scripting Operation Manual	Printed manual
Z1821A	Utilities in USB Stick	USB memory with operation manual, remote scripts instruction manual, etc.
J1583A	Optical Attenuator 10 dB LC/PC to LC/PC	
J1584A	RJ45 Cable 3 m	
J1585A	RJ48 to Crocodile Clips Cable 3 m	E1 interface cable.
J1586A	RJ48 to Crocodile Clips Cable 20 dB ATT 3 m	E1 interface cable.
J1588A	BNC Cable 2.5 m	E1, E3, E4, DS3, STM-1e, STS-3 interface cable. Impedance: 75Ω
J1589A	BNC to 1.6/5.6 Cable 2.5 m	E1, E3, E4, DS3, STM-1e, STS-3 interface cable. Impedance: 75Ω
J1591A	RJ48 to Two 3-pin Banana Plug Cable 2.5 m	E1 interface cable.
J1597A	RJ48 Balanced PDH Cable Crossed 3 m	E1 interface cable.
J1598A	Bantam Cable 3 m	DS1 interface cable.
J1710A	BNC Cable 0.2 m	BNC cable for MU100090A and main-frame external clock input connector. Impedance: 50Ω
J0127B	COAXIAL CORD, 2.0 M	BNC cable for MU100090A and main-frame external clock input connector. Impedance: 50Ω

# MT1000A Product Structure

- Warranty Products

Model/Order No.	Name
MT1000A-ES210	2 Years Extended Warranty Service
MT1000A-ES310	3 Years Extended Warranty Service
MT1000A-ES510	5 Years Extended Warranty Service
MU100010A-ES210	2 Years Extended Warranty Service
MU100010A-ES310	3 Years Extended Warranty Service
MU100010A-ES510	5 Years Extended Warranty Service
MU100011A-ES210	2 Years Extended Warranty Service
MU100011A-ES310	3 Years Extended Warranty Service
MU100011A-ES510	5 Years Extended Warranty Service
MU100090A-ES210	2 Years Extended Warranty Service
MU100090A-ES310	3 Years Extended Warranty Service
MU100090A-ES510	5 Years Extended Warranty Service
MU100090B-ES210	2 Years Extended Warranty Service
MU100090B-ES310	3 Years Extended Warranty Service
MU100090B-ES510	5 Years Extended Warranty Service



# Network Master Pro MT1000A

- Carrier Class Ethernet Installation and Troubleshooting

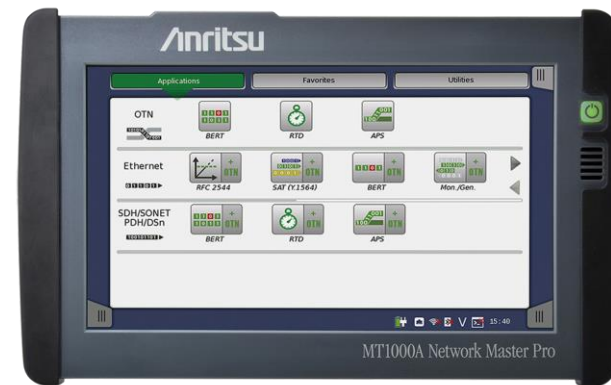

# MT1000A Product Highlights

- Easy Ethernet test solution
  - Ethernet testing
    - at 100 Gbps, 40 Gbps, 25 Gbps, 10 Gbps, 1 Gbps, 100 Mbps and 10 Mbps
  - Traffic generation up to full line rate
  - Supports IPv4 and IPv6
  - Ethernet Service Activation Test (Y.1564)
  - Automated RFC 2544 testing
    - Throughput
    - Frame Loss
    - Latency or Packet Jitter
    - Burstability
  - TCP Throughput option (RFC 6349) (Up to 10 Gbps)
  - BER testing
    - Includes frame loss and sequence error tests
  - Service disruption measurement

# MT1000A Product Highlights

- Easy Ethernet test solution—continued
  - Comprehensive statistics including:
    - Performance (utilization, Throughput, frame rate)
    - Frame statistics (frame types and errors)
    - Burst statistics
    - Frame size distribution
    - Latency and Packet Jitter measurements
    - Transmitted and received frames and bytes
  - Filters – to extract relevant parts of traffic
  - Thresholds – to highlight abnormal situations
  - Simultaneous monitoring of both line directions
  - IP Channel Statistics to identify error streams, top talkers, network attacks for up to 230 multiflow counters
  - Ethernet OAM: IEEE 802.3 (IEEE 802.3ah), IEEE 802.1ag, ITU-T Y.1731

# MT1000A Product Highlights

- Easy Ethernet test solution—continued
  - Synchronous Ethernet Test (G.826x and IEEE 1588 v2) (Up to 10G bps)
    - For Mobile Backhaul testing
  - Ethernet Multistream: Up to 16 streams per port
    - Information on Throughput, Frame Loss, Packet Jitter and latency per stream
  - Stacked VLAN (Q-in-Q): Up to 8 levels of VLAN tags
  - MPLS/MPLS-TP testing: Up to 8 levels of MPLS labels
  - PBB testing
  - 10G WAN PHY
  - Ping testing
  - Traceroute test
  - Electrical cable test and optical signal level indication
  - Frame capture for protocol analysis by Wireshark®

# MT1000A Applications – Out-of-Service Testing

- Out-of-service Ethernet testing
  - Installation and commissioning of new lines
    - Verification of quality/performance of new lines before commercial operation
  - Troubleshooting with test traffic
    - Functional testing and network behavior at different loads
  - Testing line Quality of Service (QoS)
    - Loop-back MT1000A Ethernet test signal using cable or reflector at far end

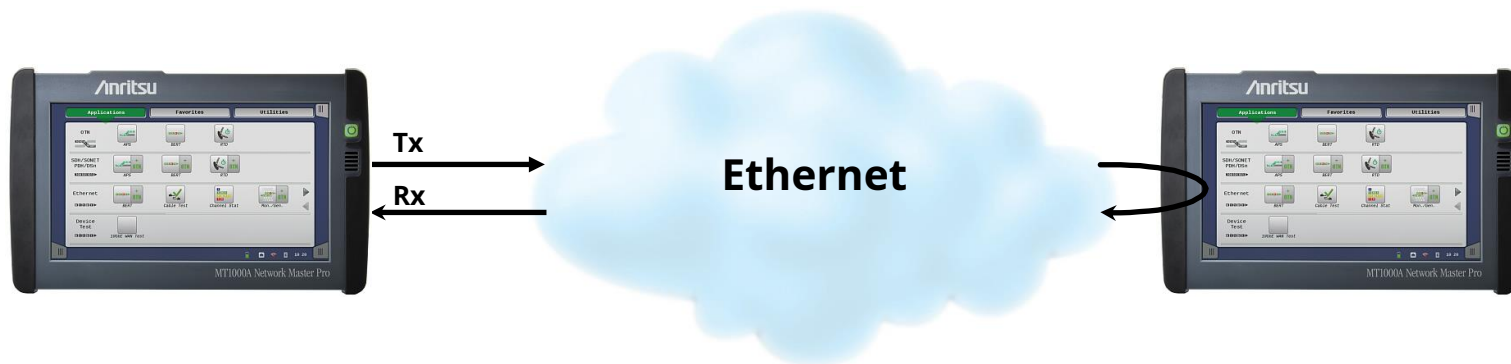

Ethernet testing with far-end reflector

# MT1000A Applications – Out-of-Service Testing

- Ethernet end-to-end testing
  - Due to nature of IP/Ethernet networks key parameters like Throughput, Frame Loss and Packet Jitter may differ in two directions of connection
    - Two instruments needed to capture data for each direction



# MT1000A Applications – Out-of-Service Testing

- Typical applications<sup>1</sup>:
  - Dual-port testing of networks or network elements
  - One-way latency measurements
  - Router testing
  - QoS verification

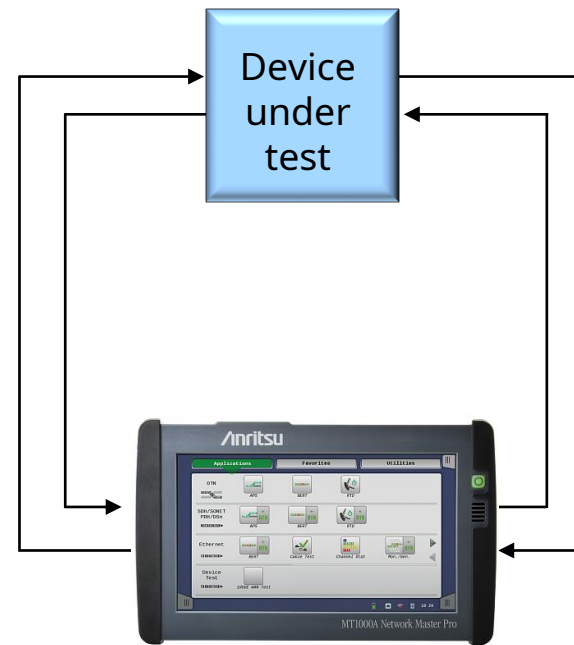

<sup>1</sup> Requires 10 Gbps dual-port option

# MT1000A Applications – In-Service Monitoring

- Typical applications<sup>1</sup>:
  - Rapid in-service diagnostics
  - In-service troubleshooting
  - Live traffic analysis and statistics

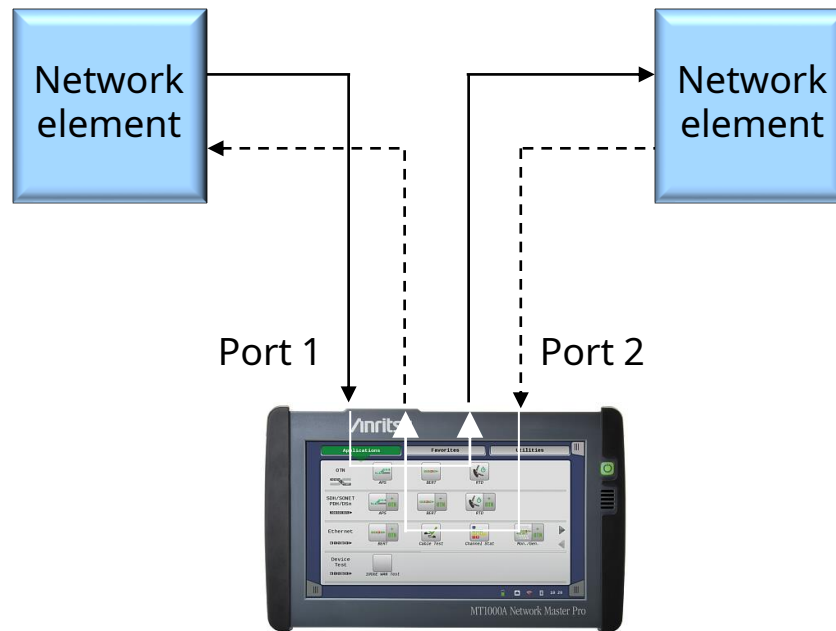

<sup>1</sup> Requires 10 Gbps dual-port option

MT1000A in Pass-through mode



# MT1000A IP Channel Statistics (Up to 10 Gbp)

- IP Channel Statistics
  - Typical root causes of network issues
    - Top talker
      - Top talker occupies major bandwidth slowing it down
    - Network attack
      - One node accessed from many sites, occupying network
    - Error Frames
      - Error frames causes re-transmission and wasted network capacity



# MT1000A IP Channel Statistics (Up to 10 Gbp)

- IP Channel Statistics
  - Finding top talker, network attack, and error frames quickly decreases downtime and recovers network performance
  - IP Channel Statistics offers simple method to top talker, network attack, and error frames just by selecting and starting filters
  - Field technicians analyze network easily without training

<b>Analysis</b>	<b>IP Channel Stats Filter</b>
Top talker	Source IP address
Network attack	Destination IP address
Error frames	(any parameter OK)

# MT1000A IP Channel Statistics (Up to 10 Gbp)

- IP Channel Statistics
  - Combination of filters
    - IPv4, IPv6 or MAC address, VLAN ID or MPLS label, IP next header (protocol), TCP/UDP ports
  - Monitoring values
    - Frame counts/rate, Throughput, Error frames, Size distribution, IPv4/IPv6 statistics, TCP/UDP statistics, etc.
  - Added value of IP Channel Statistics
    - VLAN scan
      - Throughput per VLAN ID monitored by selecting VLAN ID as filter

# MT1000A IP Channel Statistics (Up to 10 Gbp)

- Setup screen for configuring channel definitions and displayed columns
- Result screen
  - Easy switching between results from two ports

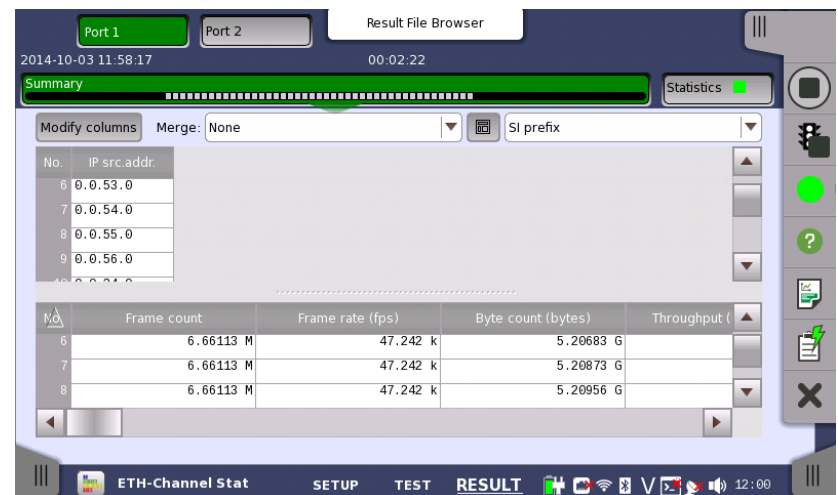
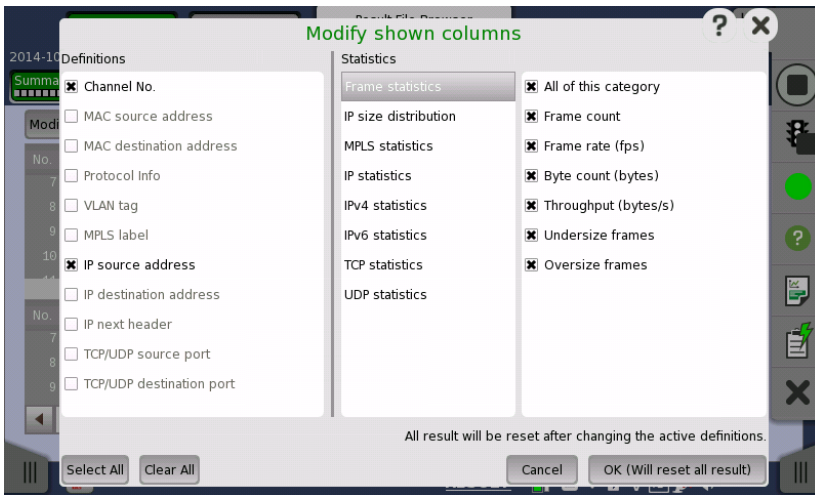

# MT1000A Ethernet Line Status

- Line alarms as LED indicators
- Displays current line status

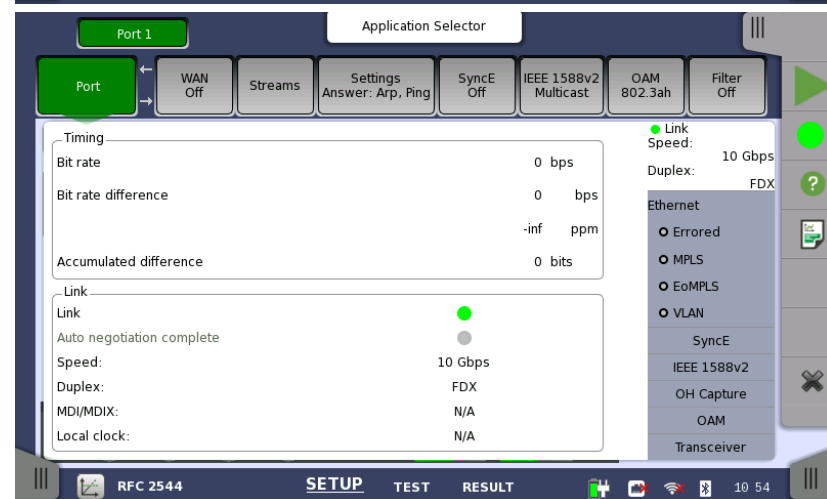
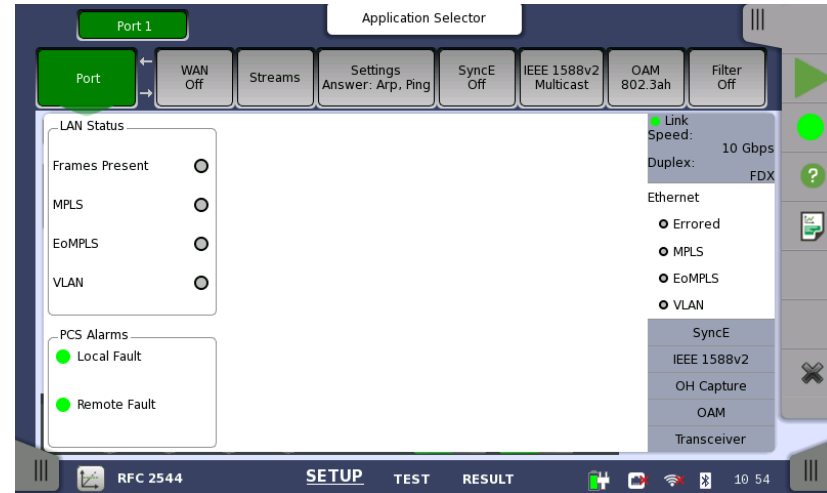

# MT1000A Cable Test for Electrical Ethernet

- Some problems on electrical Ethernet are basic:
  - Short in wire pair
  - Break in wire pair
- Cable test easily identifies such basic problems
- Cable test displays distance from instrument to fault

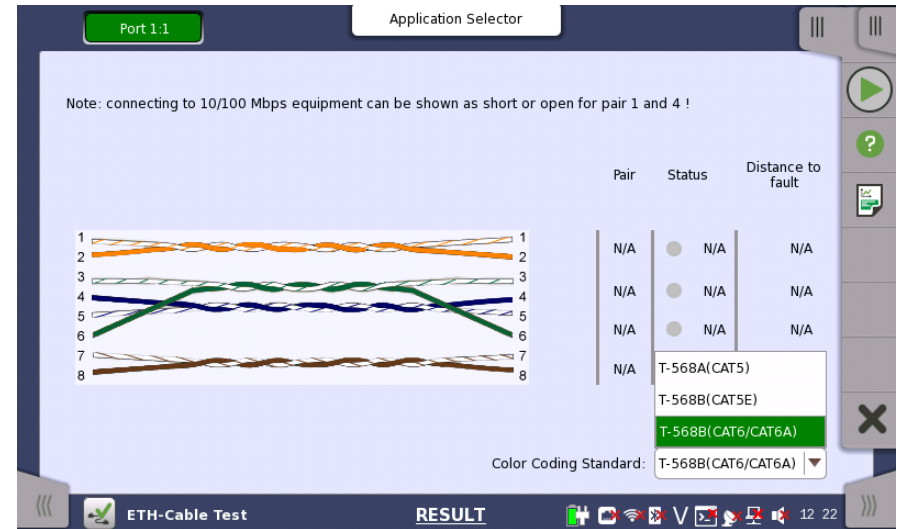

# MT1000A Signal Level Display for Optical Ethernet

- Some problems on optical Ethernet connection are basic:
  - Bent cables
  - Breaks in cable
  - Dirty connectors
- Optical signal level display easily identifies such problems

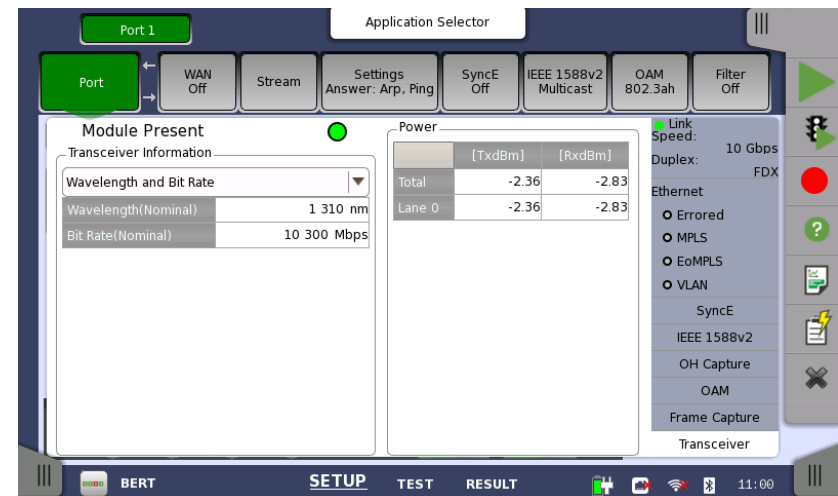

# MT1000A Service Activation Test



- What is ITU-T Y.1564?
  - Anritsu actively involved in creating Y.1564 standard
  - Defines new method for testing multiple Ethernet services on network simultaneously
  - Designed to allow service providers to assess customer end-to-end network performance including:
    - End-user traffic profiles with multiple frame sizes
    - Services with different traffic priorities on network
  - Verifies following for each surface:
    - Frame Loss, transfer time and jitter across network
    - Policing
    - Network ability to manage short-duration traffic bursts



# MT1000A Service Activation Test



- What is ITU-T Y.1564?
  - ITU-T Y.1564 completes testing in two phases:
    - Phase 1: Service Configuration Test—confirms each service configured correctly throughout network at Committed Information Rate (CIR), and others rates as required
    - Tests one service at a time

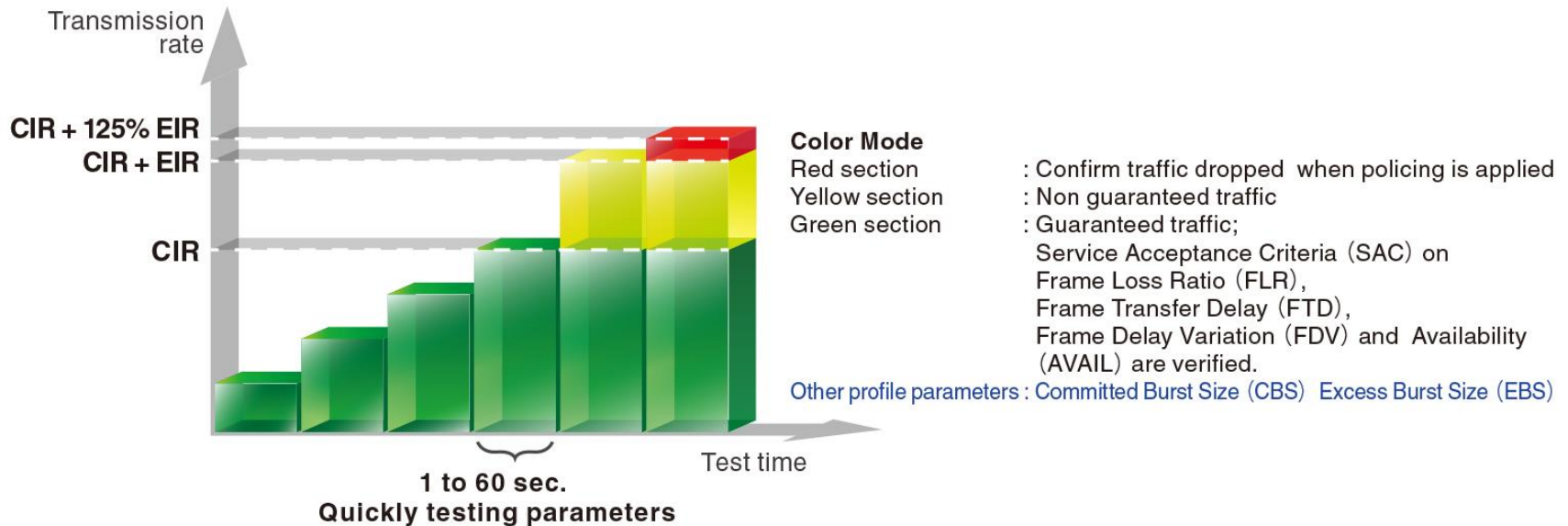

# MT1000A Service Activation Test



- What is ITU-T Y.1564?
  - ITU-T Y.1564 completes testing in two phases:
    - Phase 2: Service Performance Test—Transmits one or many services simultaneously at CIR confirming all traffic can transverse network under full service load
    - Default test time: 15 minutes, 2 hours, or 24 hours

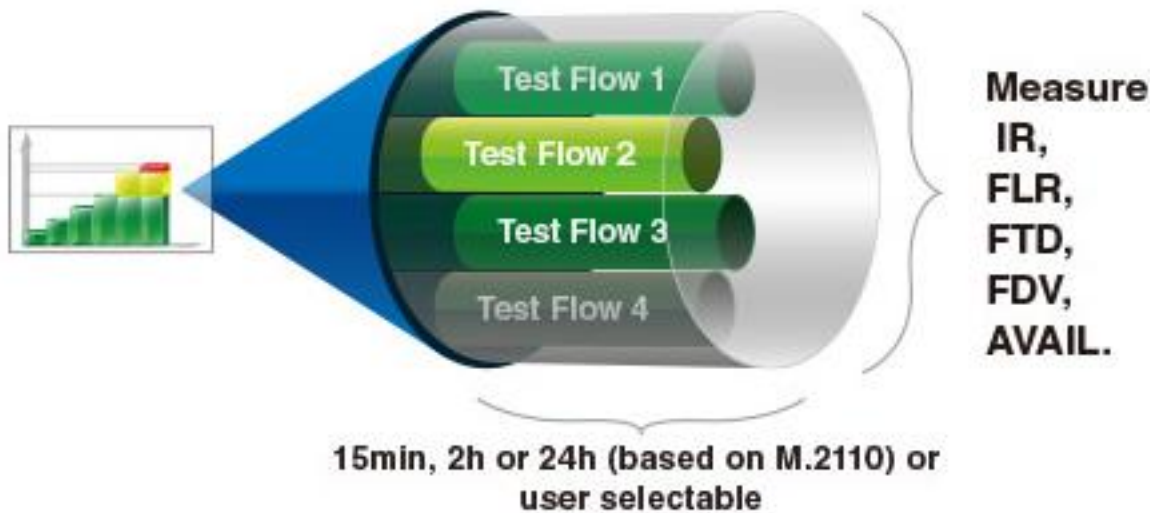

# MT1000A Service Activation Test



- What is ITU-T Y.1564?
  - Test configurations:
    - One-way test, using two testers
      - Provides individual results for each direction
      - "Preferred configuration" in Y.1564
      - How to synchronize two instruments to test one-way FTD (Frame Transfer Delay) is an issue.



- Round-trip test
  - FDV (Frame Delay Variation) may be irrelevant

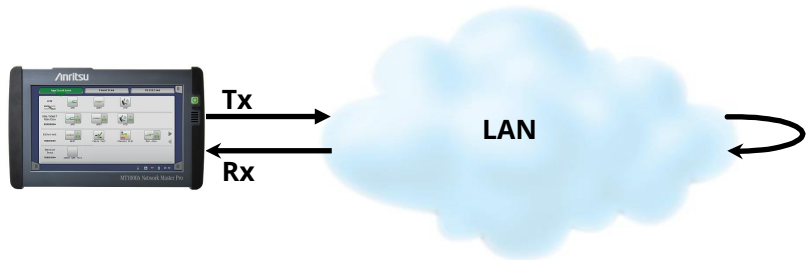

# MT1000A Service Activation Test



- What is ITU-T Y.1564?
  - RFC 2544 often used for Service Activation Test
    - Not intended use for RFC 2544:
      - "Benchmarking Methodology for Network Interconnect Devices"
      - Defines number of tests used for describing performance characteristics of network devices
  - Y.1564 intended for Service Activation Test

Item	ITU-T Y.1564	RFC 2544
<b>Designed for</b>	Service activation	Device performance
<b>Concurrent services</b>	Multiple services simultaneously	One service at a time
<b>Simulates</b>	Realistic network	One service on network
<b>Testing time</b>	Short due to simultaneous testing of services	Long due to sequential test of parameters and services
<b>Test result</b>	Directly related to SLA requirements	Link performance limit

# MT1000A Service Activation Test

- Supports tests specified in Y.1564
- Features:
  - Two-step test based on:
    - Bandwidth profile parameters: CIR, EIR, CBS, EBS
    - Performance parameters: FTD, FDV, FLR, AVAIL
  - Includes support for CM (“Color Aware”) and EMIX
  - Local–Remote operation
    - One-way test results using two MT1000A units
    - GPS add-on option for one-way FTD measurements
  - Round-trip measurements

# MT1000A Service Activation Test

- Results
  - On instrument display
    - Easy-to-understand GO/NO GO display
    - Full result details also available
  - As pdf reports

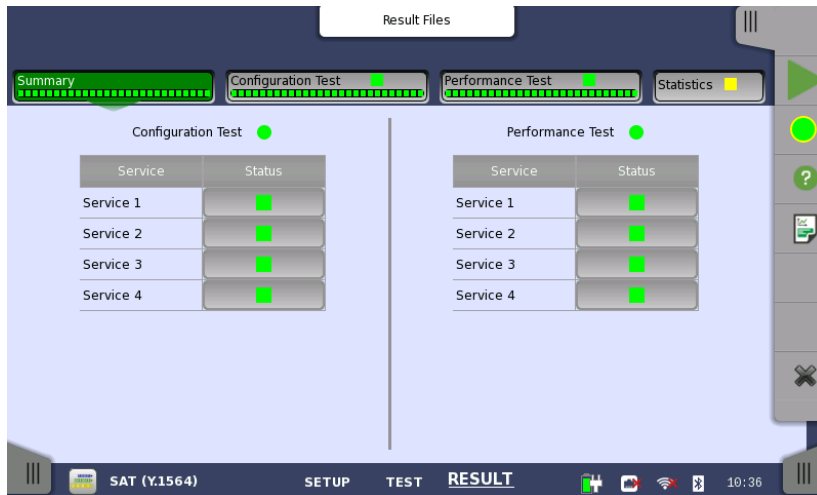

Result Summary



Result Details

# MT1000A Service Activation Test

- Setup of overall test conditions
  - Display results from local and remote instruments on local instrument when one-way test (using two instruments) selected

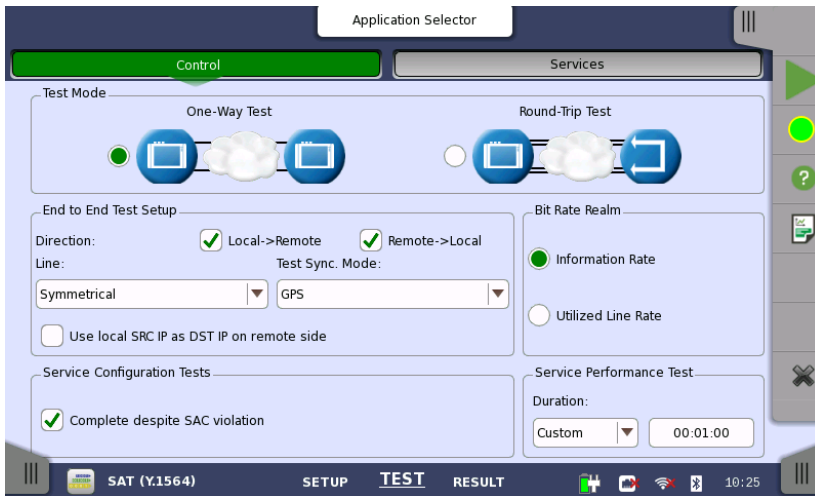

Test Setup

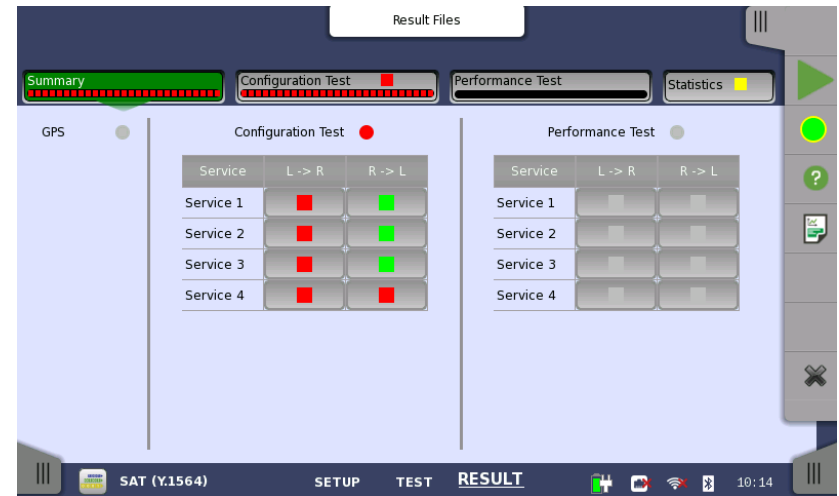

Result Summary on Local Instrument after Test

# MT1000A Service Activation Test

- Setup of each service
  - Graphical presentation of traffic profile for easy overview
  - Full flexibility in programming parameters

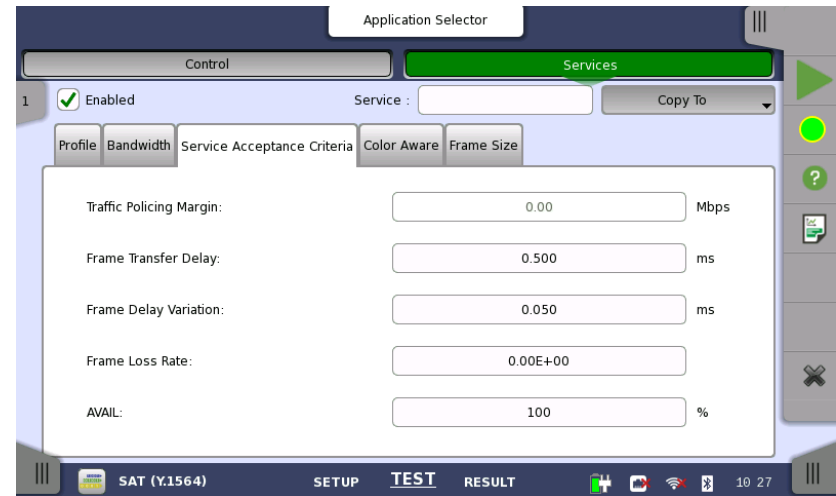
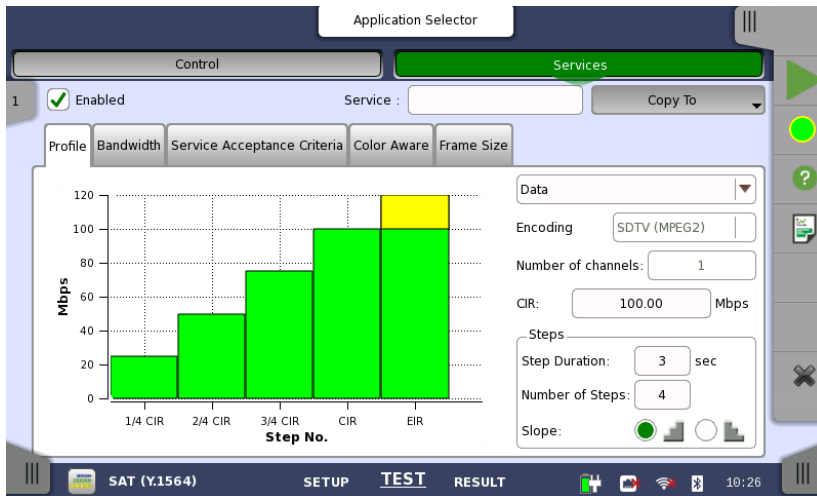



# MT1000A Service Activation Test

- GPS synchronization
  - Accurate information on one-way FTD with GPS synchronization option
    - Once synchronized, MT1000A holds synchronization for period of time
      - Relevant when difficult to get GPS signals at test site

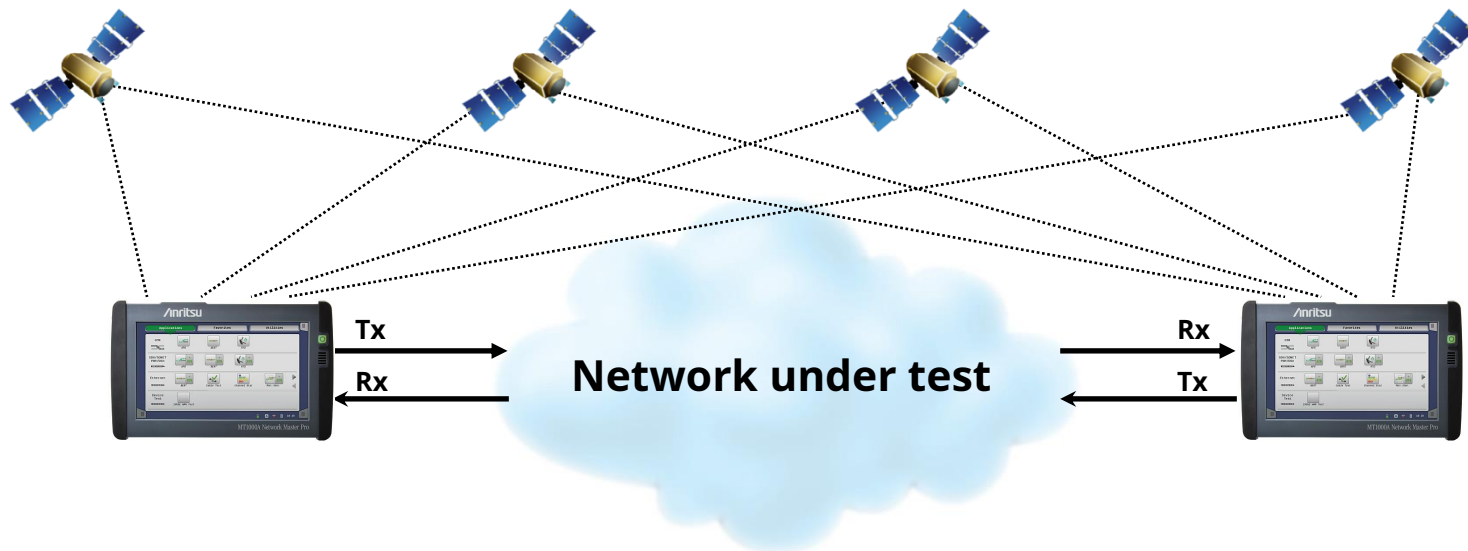

# MT1000A RFC 2544 Analysis

- ETF RFC 2544 "Benchmarking Methodology for Network Interconnect Devices"

- Defines number of tests used to describe performance characteristics of network devices
- Throughput — for selected layer
- Frame Loss
- Latency
- Packet jitter
- Burstability

- Easy-to-interpret graphs
- Full-detail tables

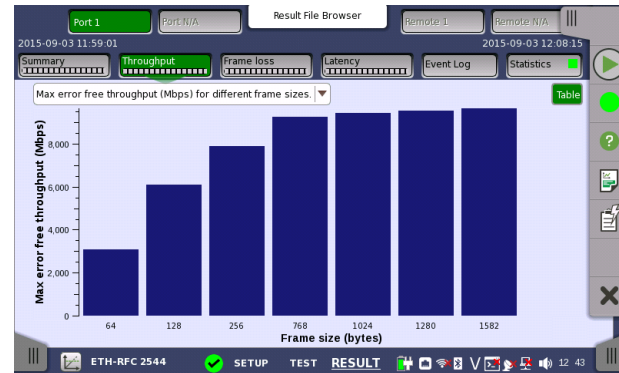

Graphs are bar graphs with legends (where applicable), giving users a better overview of results

Rep	Step	Fr size	Frames	Fr rate (fps)	Util (%)	Tput (Mbps)	Frames lost
0	1	64	44.642857 M	14.880952 M	100.00		
			44.642857 M		100.00	3095.241552	0
			40.178571 M		90.00		
			40.178571 M	13.392857 M	90.00	2785.714464	0
			35.714285 M		80.00		
			35.714285 M	11.904761 M	80.00	2476.196944	0
			31.250000 M		70.00		
			31.250000 M	10.416666 M	70.00	2166.671520	0
			26.785714 M		60.00		

RFC 2544 tables fit the screen width - no need for horizontal scrolling

# MT1000A RFC 2544 Analysis

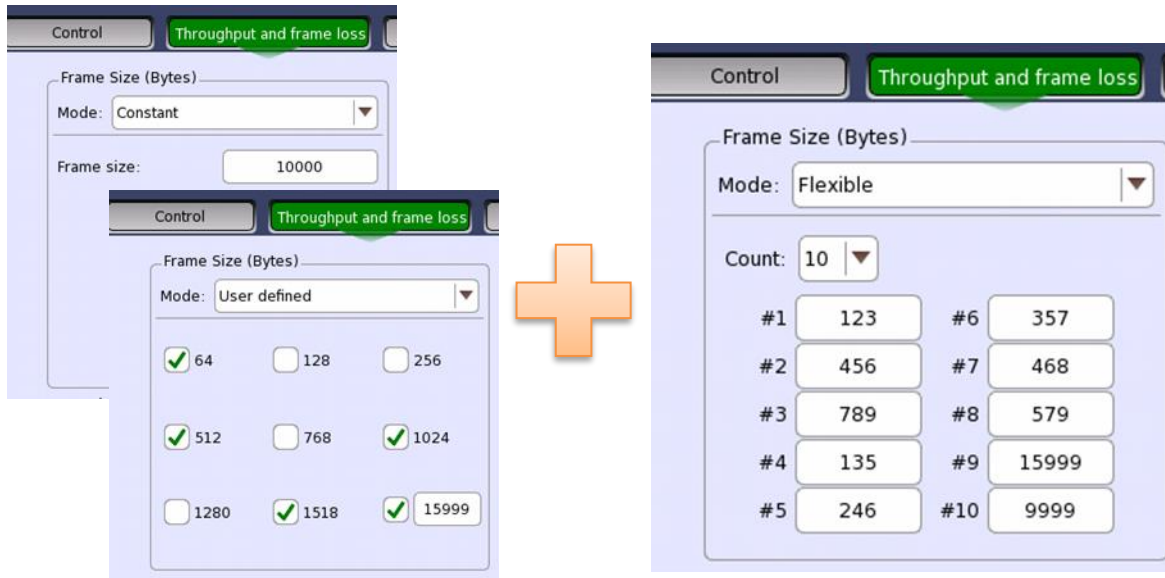

- 10 Types Max.
- Setting range of 50 ~ 16000 bytes
- Ideal for Latency and Burst measurements

Can flexibly measure multiple Frame sizes with one sequence to check device-unique properties for Frame-size related specifications, such as Maximum Transmission Unit (MTU), etc., to support easy Boundary Testing of Frame size-dependent properties.

### Useful Point !

Although only one size can be measured in the Constant mode, measuring multiple sizes shortens the measurement time and simplifies comparison of measurement results between sizes.

# MT1000A RFC 2544 Reporting

- Report tables are organized like the GUI with Tx row followed by Rx row, making it easy to find faulty test areas with Frame loss.
  - New tables display per-port test results before actual results tables.
  - Users can quickly identify combinations of Frame sizes and utilizations with problems.

Test	Step	Frame	Frames	TX rate (Gbps)	RX rate (Gbps)	Test (Mbps)	Frames lost
P1 Tx	0	1	64	44.642857 M	14.869052 M	220.00	3096.201532
P1 Rx	0	2	64	44.642857 M	44.642857 M	220.00	0
P1 Tx	0	2	64	40.119375 M	13.302987 M	50.00	2785.74464
P1 Rx	0	2	64	40.119375 M	40.119375 M	50.00	0
P1 Tx	0	3	64	36.714285 M	11.904761 M	80.00	2476.19084
P1 Rx	0	3	64	36.714285 M	36.714285 M	80.00	0
P1 Tx	0	4	64	31.250000 M	9.418688 M	70.00	2168.87320
P1 Rx	0	4	64	31.250000 M	31.250000 M	70.00	0
P1 Tx	0	5	64	26.785714 M	8.828571 M	60.00	1887.14056
P1 Rx	0	5	64	26.785714 M	26.785714 M	60.00	0
P1 Tx	0	6	64	22.321428 M	7.468476 M	50.00	1547.82870
P1 Rx	0	6	64	22.321428 M	22.321428 M	50.00	0

Util (%)	Frame size					
	64	128	256	512	1024	1536
200.00	Pass	Pass	Pass	Pass	Pass	Pass
90.00	Pass	Pass	Pass	Pass	Pass	Pass
80.00	Pass	Pass	Pass	Pass	Pass	Pass
70.00	Pass	Pass	Pass	Pass	Pass	Pass
60.00	Pass	Pass	Pass	Pass	Pass	Pass
50.00	Pass	Pass	Pass	Pass	Pass	Pass
Frame size						
100.00	Pass					
90.00	Pass					
80.00	Pass					
70.00	Pass					
60.00	Pass					
50.00	Pass					

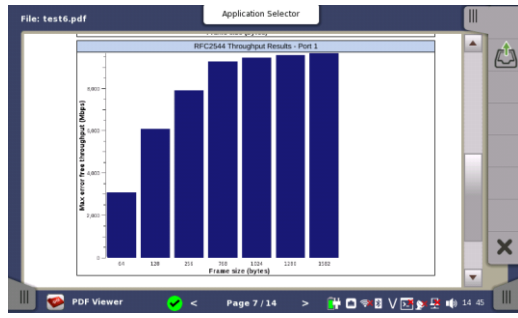

RFC 2544 graphs same as GUI

RFC2544 Summary	
Test at	2023-09-03 11:50:03
Test on	2023-09-03 12:08:15
GPS status	Not available
Test mode	Single ended network test
Mode	Compass
Throughput	Completed
Frame loss	Completed
Latency	Completed
Throughput and frame loss	Not configured
Burst	Not configured

PDF reports are displayed with the built-in PDF viewer

RFC 2544 Summary section with new table showing which tests completed

# Benefit of RFC 2544 End-to-End Test

- Typical test set-up with one instrument and reflector or loopback OK for symmetrical links:

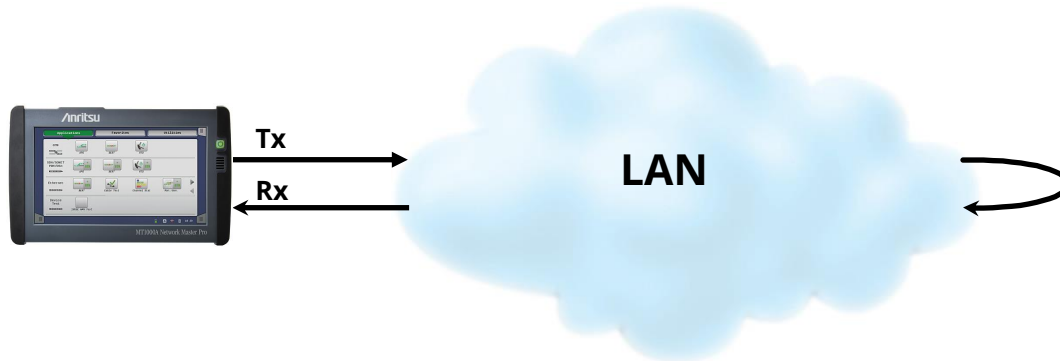

- For Ethernet links carried over asymmetrical connections (xDSL, WIMAX) throughput tests only reflect performance of link direction with lowest capacity
- Symmetrical typical test set-up does not identify transmission performance differences between two link directions

# MT1000A RFC 2544 End-to-End Test

- RFC 2544 end-to-end test with Local-Remote relationship
  - Needed for test of Ethernet links over asymmetrical connections
  - Identifies transmission performance differences between two directions in link
  - User sets test at local instrument which exchanges set-up and results with remote instrument to be controlled
  - Tests Throughput, Frame Loss and Burstability
  - Tests two lines simultaneously



# MT1000A Ethernet Ping Test

- Ping test applications:
  - Installation and commissioning
  - Troubleshooting and maintenance
- Popular tool for testing:
  - Continuity
  - Connectivity
  - Response time

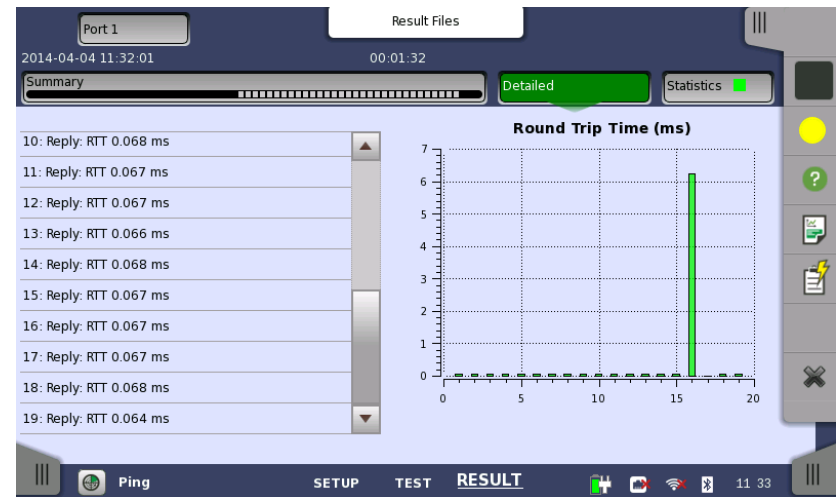
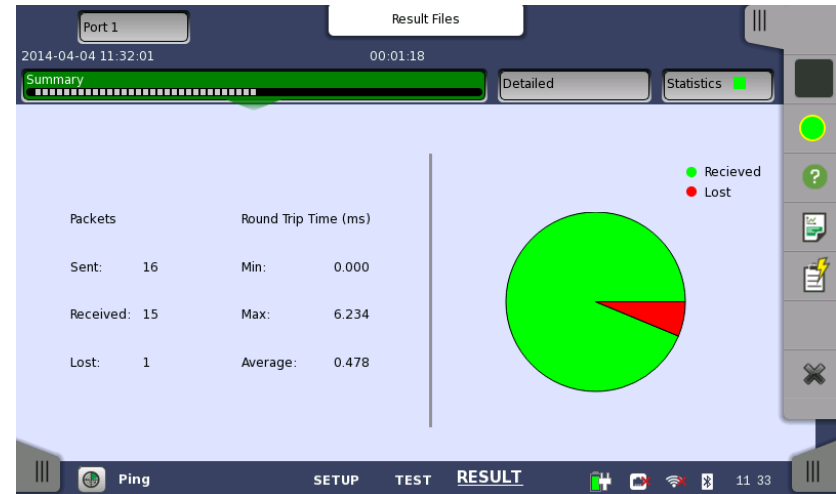

# MT1000A Ethernet Traceroute Test

- Traces IP route over IP network
- Ping timing data per hop

Port 1 Result Files

2014-04-04 11:36:24 00:00:01 2014-04-04 11:36:25

Summary Statistics

Hop	Host	Min Ping (ms)	Max Ping (ms)	Avg Ping (ms)	Timeout
1	0.0.0.0 (destination)	0.065	0.070	0.067	

Traceroute SETUP TEST RESULT 11:36

Port 1 Application Selector

Test Duration:

Number of attempts:

Max number of hops:

Ping each hosts:  times

Threshold:

Timeout:  ms

Traceroute SETUP TEST RESULT 11:37



# MT1000A Ethernet BER Tests

- Traditional test of physical connection
- Generates and detects test patterns
- Counts errors in received test pattern
- Color-coded errors and alarms for easy overview
- Pattern generation:
  - Unframed
  - Layer 2 (Mac address)
  - Layer 3 (with IP header)
  - Layer 4 (with UDP/TCP header)
- Detects sequence errors and loss of sequence synchronization
- Frame loss count and frame loss seconds

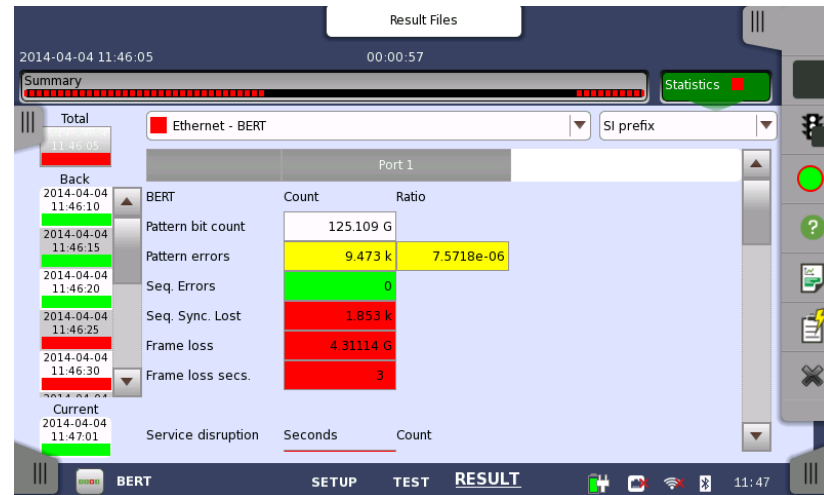
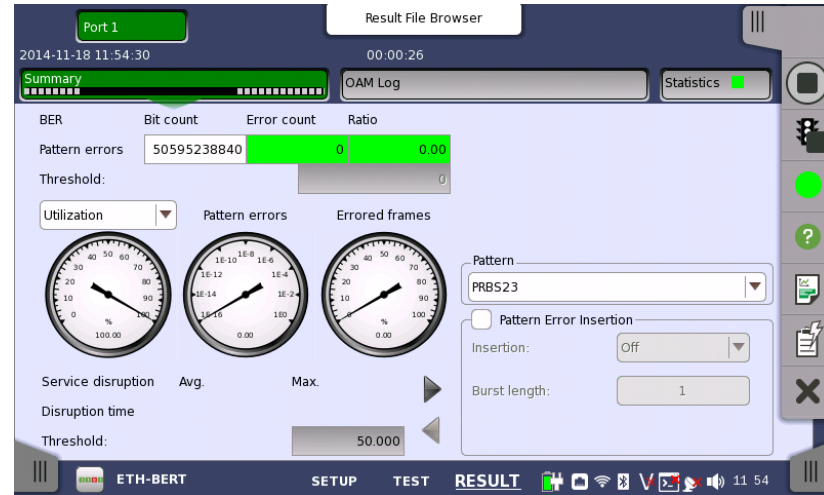

# MT1000A BER Tests

- Layered Throughput analysis

Frame representation												Throughput Calculation
IFG	Pre-ambble	MAC header	MPLS (opt)	EoMPLS (opt)	VLAN (opt)	LLC (opt)	SNAP (opt)	IP head	UDP TCP	PAYLOAD	CRC	Data layer
IFG	Pre-ambble	MAC header	MPLS (opt)	EoMPLS (opt)	VLAN (opt)	LLC (opt)	SNAP (opt)	IP head	UDP TCP	PAYLOAD	CRC	Network layer
IFG	Pre-ambble	MAC header	MPLS (opt)	EoMPLS (opt)	VLAN (opt)	LLC (opt)	SNAP (opt)	IP head	UDP TCP	PAYLOAD	CRC	Link layer
IFG	Pre-ambble	MAC header	MPLS (opt)	EoMPLS (opt)	VLAN (opt)	LLC (opt)	SNAP (opt)	IP head	UDP TCP	PAYLOAD	CRC	Physical layer no preamble
IFG	Pre-ambble	MAC header	MPLS (opt)	EoMPLS (opt)	VLAN (opt)	LLC (opt)	SNAP (opt)	IP head	UDP TCP	PAYLOAD	CRC	Physical layer
min. IFG	Pre-ambble	MAC header	MPLS (opt)	EoMPLS (opt)	VLAN (opt)	LLC (opt)	SNAP (opt)	IP head	UDP TCP	PAYLOAD	CRC	Utilization layer
<p style="text-align: center;">← CMA 3000 frame size (does not include Preamble) →</p> <p style="text-align: center;">Area included in throughput calculation</p> <p>min. IFG   Area included in utilization calculation</p>												Frame information

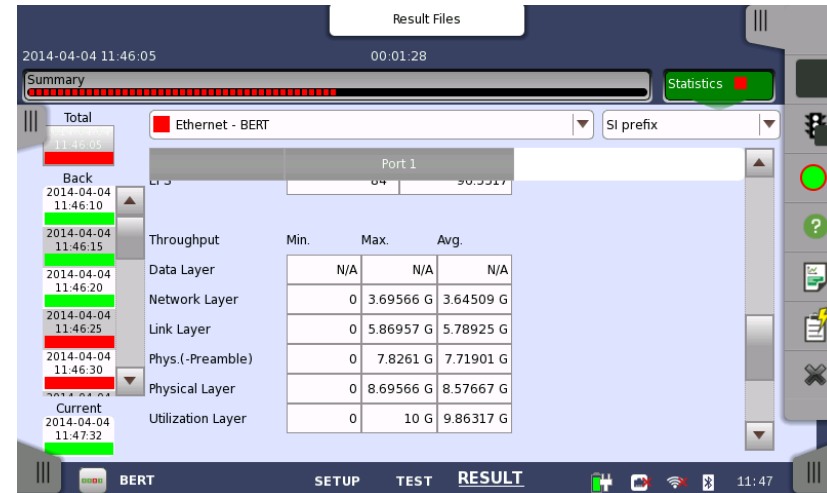

# Why Service Disruption on Ethernet Links?

- Many Ethernet links carried over OTN/SDH/SONET via backbone network
  - OTN/SDH/SONET networks sometimes have Automatic Protection Switching (APS)
  - If OTN/SDH/SONET network line fails, APS switches traffic to working line
  - Switch and service disruption should be completed in less than 50 ms

# MT1000A Service Disruption Measurement

- Service disruption can be measured as part of BER test
  - Using far-end loopback or two MT1000A testers
  - Max. acceptable service disruption time can be set
    - Color-coded results when max. time exceeded

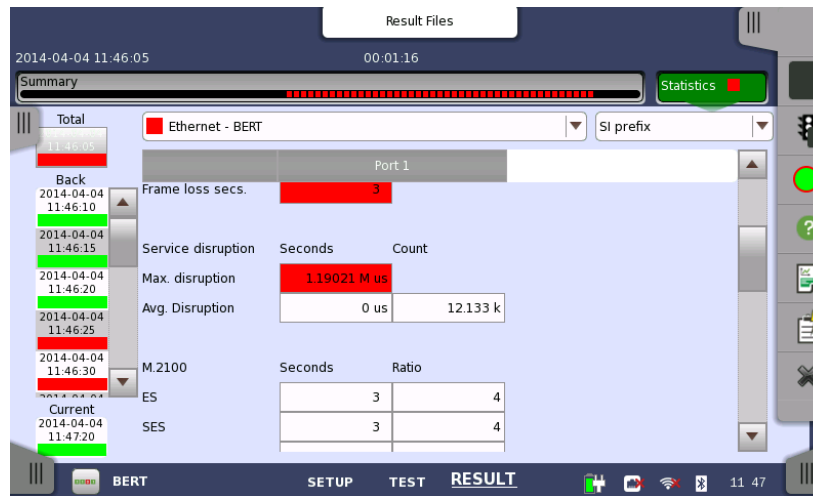

# MT1000A Ethernet Signal Analysis

- Frame performance
- Frame type statistics
- Frame size distribution statistics
- Burst statistics
- Transmit statistics
- Full-detail tables
- User-defined thresholds to highlight problems

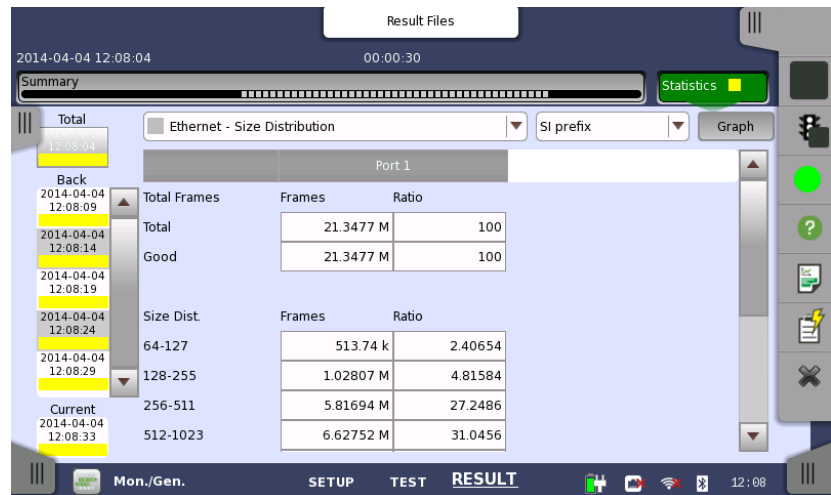

# MT1000A Ethernet Statistics Export

- Export all Ethernet Statistics per interval setting 1, 2, 5 sec etc.
- Select required sections to export into CSV format
- Open CSV file in Excel (or other)
- Analyze stat's for required data
- Graph statistical results
- Graph and compare different results over time

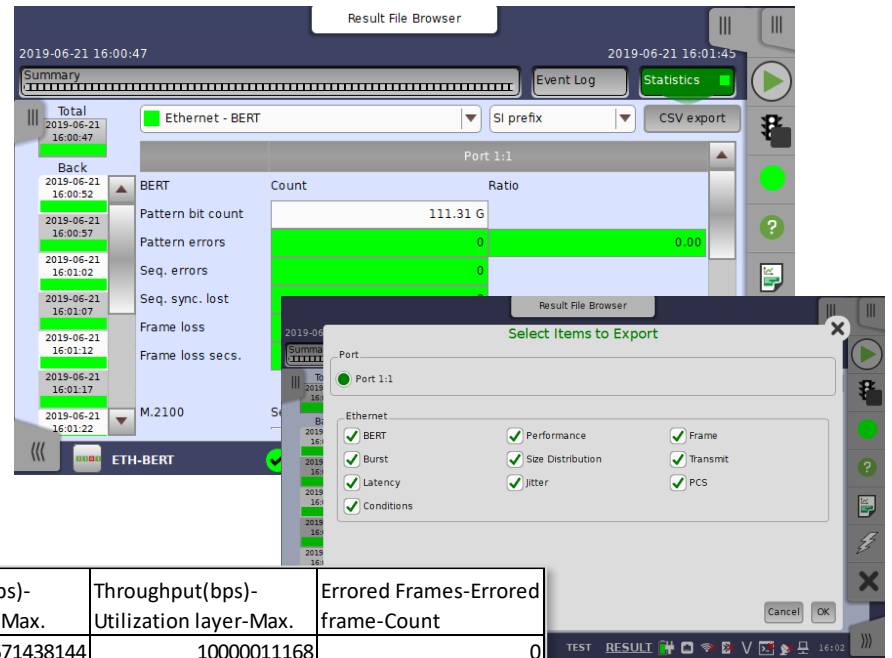

date/time	Relative time	Throughput(bps)-Link layer-Max.	Throughput(bps)-Phys.(-preamble)-Max.	Throughput(bps)-Physical layer-Max.	Throughput(bps)-Utilization layer-Max.	Errored Frames-Errored frame-Count
21/6/2019 16:00:47	0:00:00	5476196592	7619056128	8571438144	10000011168	0
21/6/2019 16:00:52	0:00:05	5476196592	7619056128	8571438144	10000011168	0
21/6/2019 16:00:57	0:00:10	5476196592	7619056128	8571438144	10000011168	0
21/6/2019 16:01:02	0:00:15	5476196592	7619056128	8571438144	10000011168	0
21/6/2019 16:01:07	0:00:20	5476196592	7619056128	8571438144	10000011168	0
21/6/2019 16:01:12	0:00:25	5476196592	7619056128	8571438144	10000011168	0
21/6/2019 16:01:17	0:00:30	5476196592	7619056128	8571438144	10000011168	0
21/6/2019 16:01:22	0:00:35	5476196592	7619056128	8571438144	10000011168	0
21/6/2019 16:01:27	0:00:40	5476196592	7619056128	8571438144	10000011168	0
21/6/2019 16:01:32	0:00:45	5476196592	7619056128	8571438144	10000011168	0
21/6/2019 16:01:37	0:00:50	5476196592	7619056128	8571438144	10000011168	0
21/6/2019 16:01:42	0:00:55	5476196592	7619056128	8571438144	10000011168	0

# MT1000A Latency and Packet Jitter Measurements

- Latency and packet jitter can cause problems for real-time services like VoIP
  - Part of statistical measurements
  - User selects included information

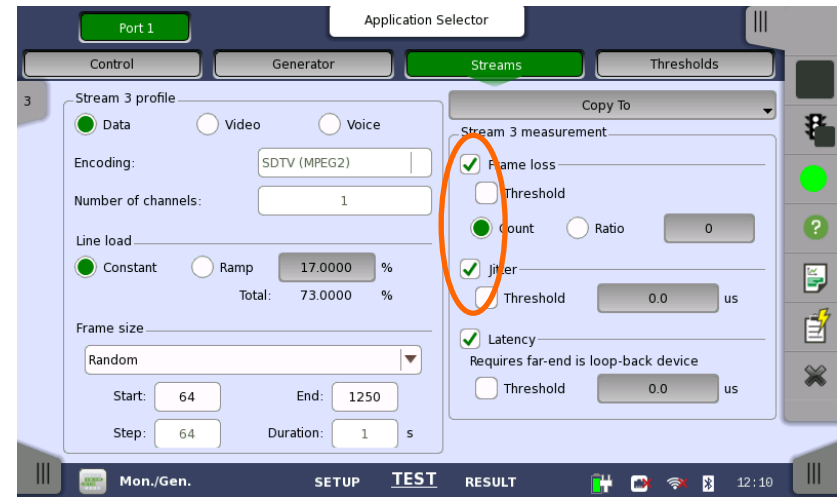
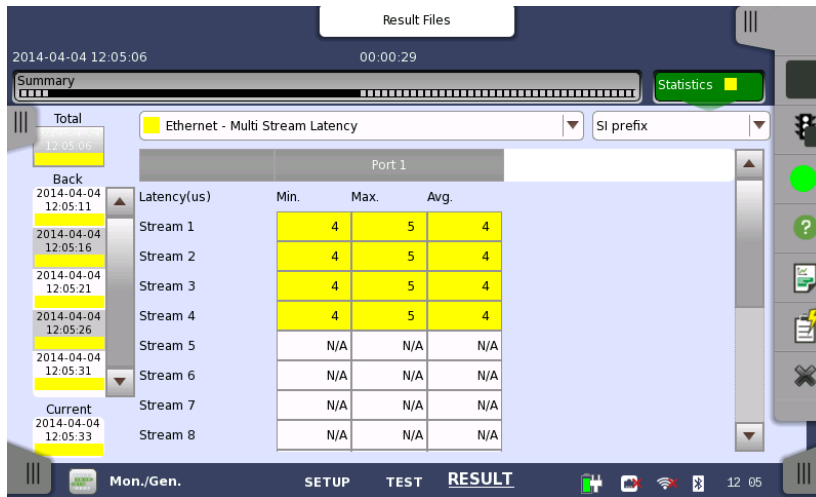

# Benefit of Ethernet Multistream Test

- By sending several traffic streams with different priority settings, the user can verify that high-priority traffic is transported better (i.e. has lower frame loss) through a congested network than low-priority traffic.

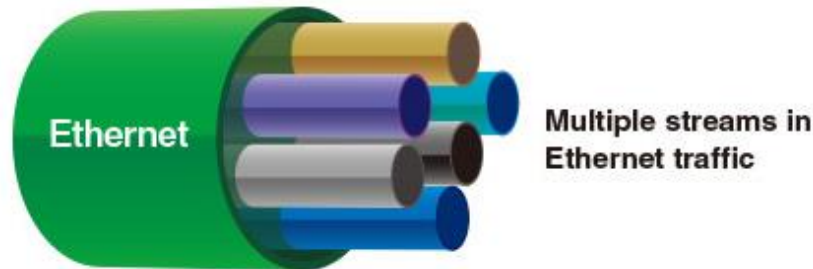

- VoIP traffic is often given high priority to ensure service quality
  - Sometimes DSCP/TOS byte used to give high priority
  - Other times high priority given to selected TCP/UDP ports
- Some operators allocate certain traffic capacity to each traffic type on link with limited capacity
- User can verify that each traffic types gets allocated capacity by sending several traffic streams with different type indications
  - Traffic type indicated by VLAN tags



# MT1000A Ethernet Multistream Test

- Using MT1000A, user can generate up to 16 streams per port on Ethernet link
  - Individual settings for traffic load and header information for streams, including DSCP/TOS byte and TCP/UDP port numbers for each stream

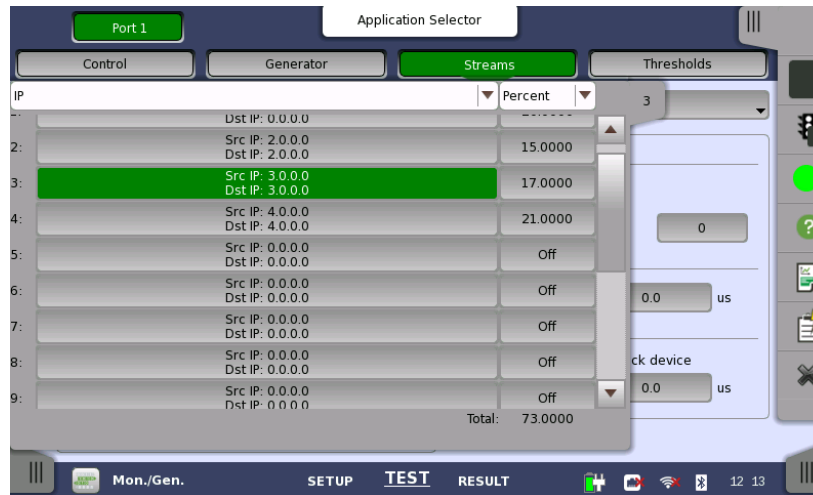

Stream Selector and Overview

# MT1000A Ethernet Multistream Test

- Multistream function displays frame loss for up to 16 streams per port, making it easy to spot whether high-priority traffic has lower frame loss than low-priority traffic



# Simple Stream Address Creation

- When generating Ethernet and IPv4/v6 test Frames, a function supports creation of [Increment], [Decrement], and [Random] streams for the address specified location, resulting in shorter test setting times.

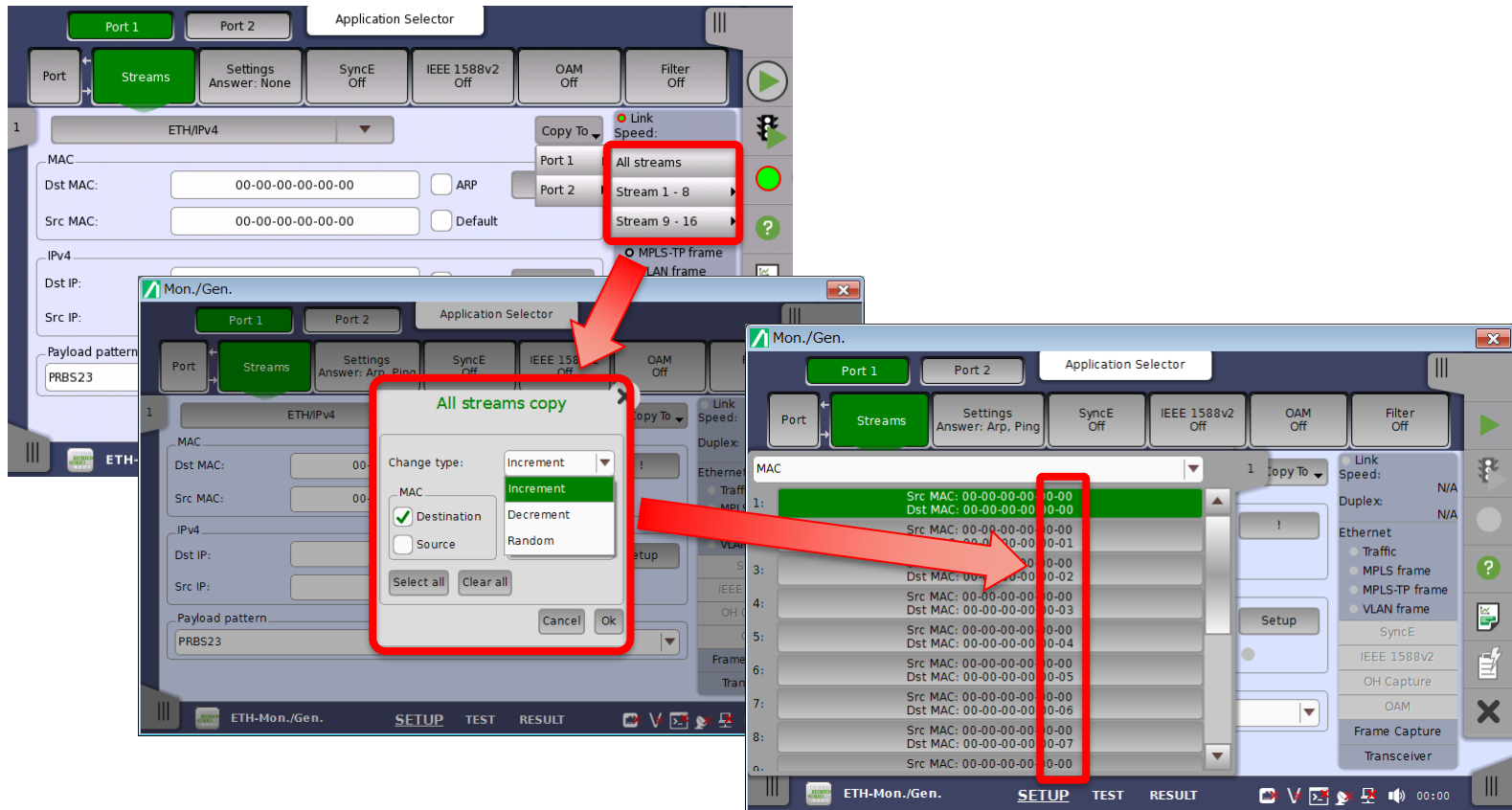

# Ethernet function for broadcast packet networks

The following functions are supported for measuring broadcast packet networks.

- IGMP/MLD client function for multicast group Join/Leave
- IEEE1588V2 (PTP) SMPTE 2059-2 profile for video streaming IP upgrade

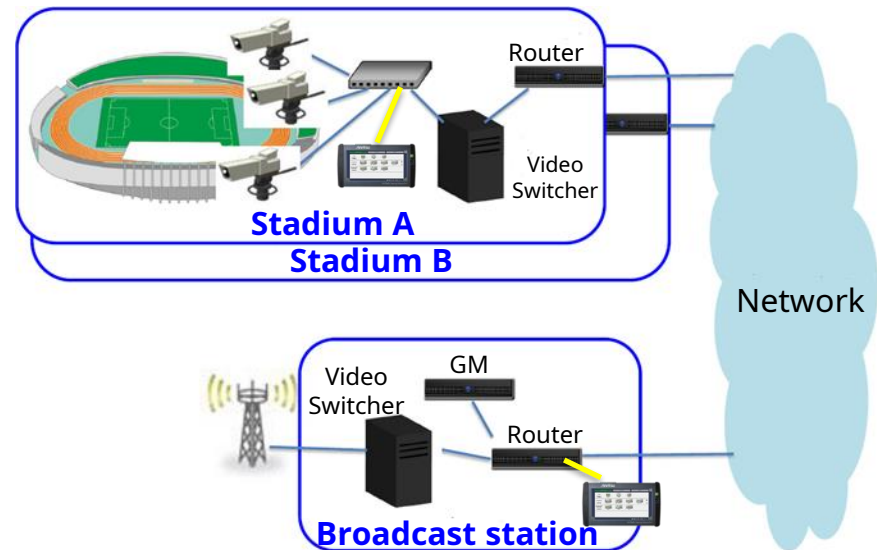
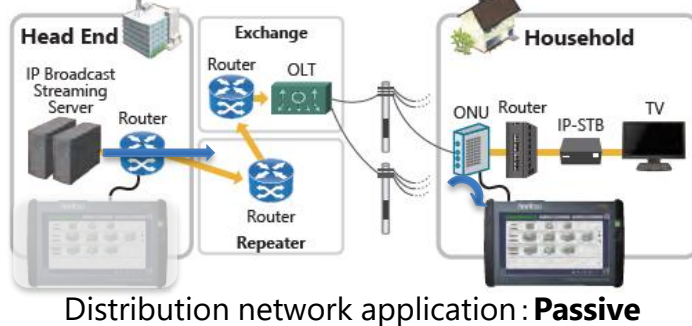
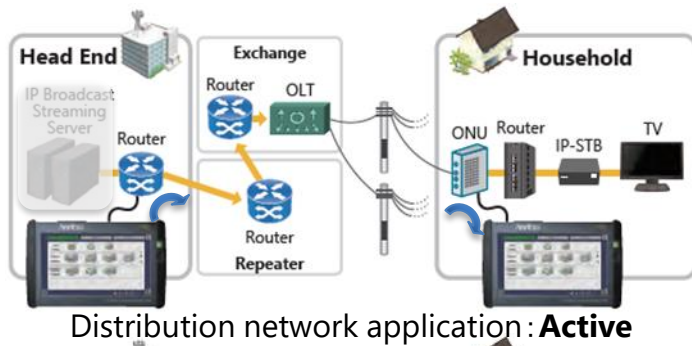

Adding end-to-end test for broadcast packet networks assures QoS evaluations using throughput and one-way latency measurement at network installation, as well as easy and efficient network maintenance.

Only one unit is all that is necessary to evaluate video streaming network time synchronization performance and check time synchronization protocols.

# VLAN Background

- Virtual Local Area Networks (VLANs) - IEEE 802.1Q
  - Segment LAN on organizational basis, by functions, project teams or applications
    - Each VLAN has ID and priority
      - 802.1p priority bits (3) segment traffic into eight Classes of Service (CoS), enabling traffic differentiation
      - 12-bit ID supports 4096 VLANs
- Stacked VLAN (“Q-in-Q”) IEEE 802.1ad
  - VLAN carried on VLAN
    - Method to provide more VLAN IDs
    - Allows service provider to carry customer VLAN traffic transparently service provider VLAN
    - Sometimes service provider and/or customer use more than one VLAN tag

# MT1000A Ethernet Stacked VLAN Function

- Insert up to eight layers of VLAN tags into Ethernet frame
  - Can be combined with Multistream function
  - Special layer naming when two layers selected
    - S-VLAN – Service provider VLAN
    - C-VLAN – Customer VLAN

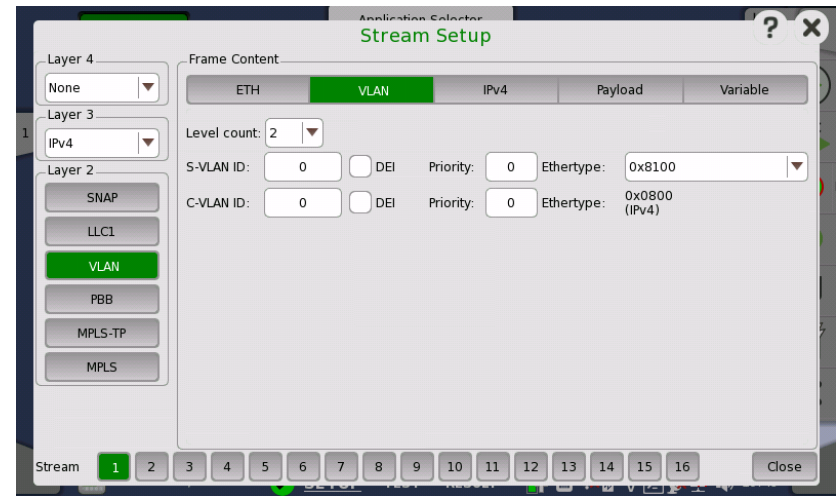
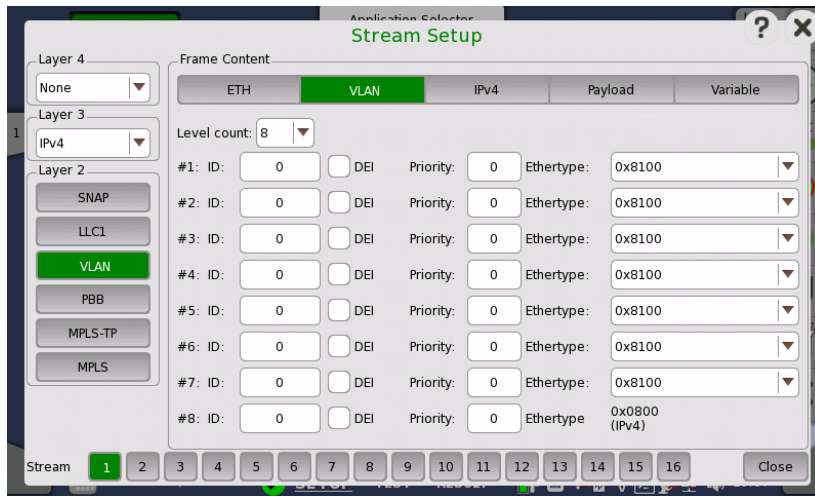

CFI bit renamed to DEI (Drop Eligible Indicator)

# MT1000A Ethernet Stacked VLAN Function

- VLAN information:
  - Indicates detected VLAN tagged frames in Status pane
  - Counts detected VLAN tagged frames and max. VLAN tag level in statistical measurements
  - Displays information on last received VLAN frame

Category	Value
Broadcast	0
Pause	0
VLAN	9.29515 M, 42.6743
MPLS	1.73047 M, 7.94464
EoMPLS	0
MiM	0
VLAN Max Level	8
MPLS Max Level	1
MPLS Min Level	N/A

Application Selector: Port 1

Port: Port 1 | WAN Off | Streams | Settings Answer: Arp | SyncE Off | IEEE 1588v2 Multicast | OAM 802.3ah | Filter Off

Link Speed: 10 Gbps | Duplex: FDX

ETH/VLAN/IPv4 | Copy To

Dst MAC: 00-00-00-00-00-00 | ARP | Src MAC: 00-00-00-00-00-00 | Default

IPv4: Dst IP: 3.0.0.0 | DNS | Setup | Src IP: 3.0.0.0 | DHCP

VLAN: #1 ID: 0 | #2 ID: 0 | Payload pattern: PRBS23

Ethernet: Errored, MPLS, EoMPLS, VLAN, SyncE, IEEE 1588v2, OH Capture, OAM, Frame Capture, Transceiver

Category	ID	Priority
Last Received		
VLAN 1	N/A	N/A
VLAN 2	N/A	N/A
VLAN 3	N/A	N/A
VLAN 4	N/A	N/A
VLAN 5	N/A	N/A
VLAN 6	N/A	N/A
VLAN 7	N/A	N/A
VLAN 8	N/A	N/A

# MPLS Background

- Multi-Protocol Label Switching (MPLS)
  - Carries data; considered to be between Layer 2 (Data Link Layer) and Layer 3 (Network Layer); often called “Layer 2.5”.
  - Simplifies point-to-point routing
    - MPLS header has one or more 'labels' (label stack) and each label has four fields:
      - 20-bit label value
      - 3-bit field for QoS priority
      - 1-bit bottom of stack flag
      - 8-bit TTL (time to live) field
- EoMPLS (Ethernet over MPLS) or PWE3 (Pseudo-Wire Emulation Edge-to-Edge)
  - Defines method to transport Layer 2 protocol across MPLS network



# MT1000A MPLS/MPLS-TP Function

- Stacked MPLS generation
  - Inserts up to 8 layers of MPLS labels into Ethernet frame
  - Can be combined with Multistream facility
  - EoMPLS Control word can be added with MPLS-TP

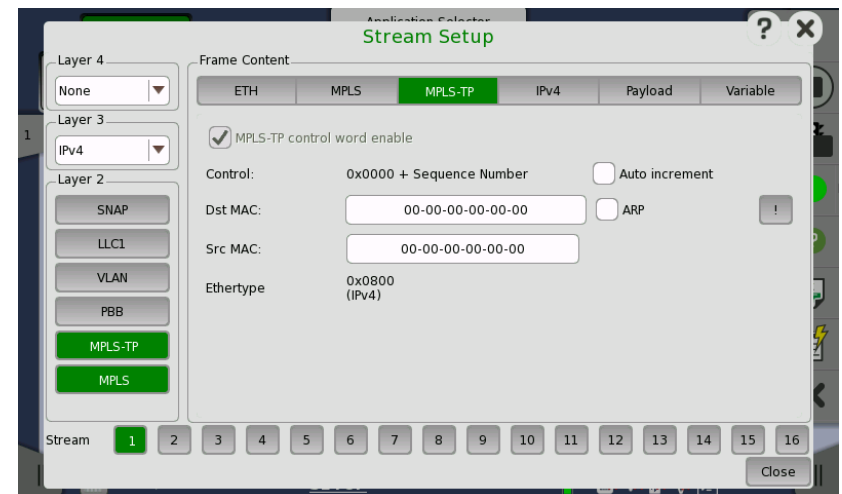
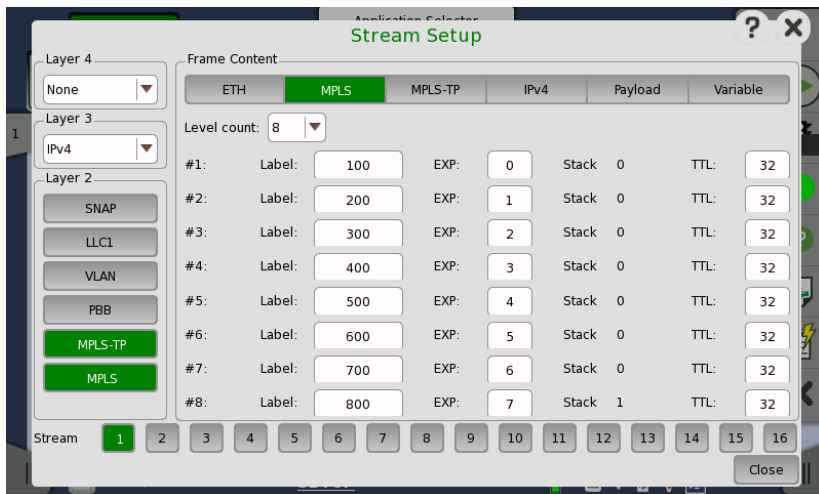

# MT1000A MPLS/MPLS-TP Function

- MPLS information:
  - Indicates detection of MPLS and EoMPLS frames in Status pane
  - Counts detected MPLS and MPLS-TP (EoMPLS) frames and max. MPLS layer
  - Displays information on latest received MPLS frames

Result File Browser

2014-07-03 10:37:58 00:00:16

Summary OAM Log Statistics

Total Ethernet - Frame SI prefix

	Port 1	
Pause frame	0	0.00 %
VLAN frame	0	0.00 %
MPLS frame	173.611 M	100.00 %
MPLS-TP frame	173.611 M	100.00 %
PBB frame	0	0.00 %
VLAN max level	N/A	
VLAN min level	N/A	
MPLS max level	8	
MPLS min level	8	

Mon./Gen. SETUP TEST RESULT 10:38

Result File Browser

2014-07-03 10:37:58 00:00:36

Summary OAM Log Statistics

Total Ethernet - Frame SI prefix

	Label	Priority	TTL
MPLS 1	100	0	32
MPLS 2	200	1	32
MPLS 3	300	2	32
MPLS 4	400	3	32
MPLS 5	500	4	32
MPLS 6	600	5	32
MPLS 7	700	6	32
MPLS 8	800	7	32

Mon./Gen. SETUP TEST RESULT 10:38

# MT1000A MPLS-TP Function

- MPLS-TP information:
  - Activation of MLPS-TP OAM function

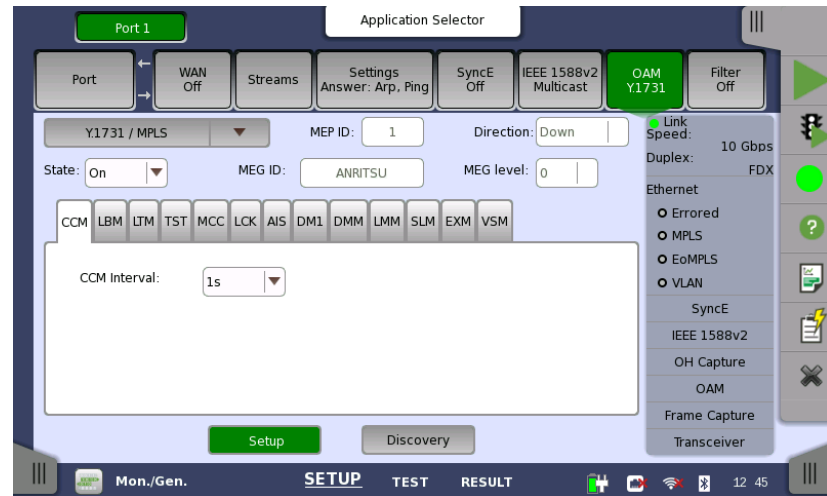

# MT1000A PBB Function

- PBB (Mac-in-Mac) information:
  - Counts PBB frames at result page
  - Can be combined with Multistream facility

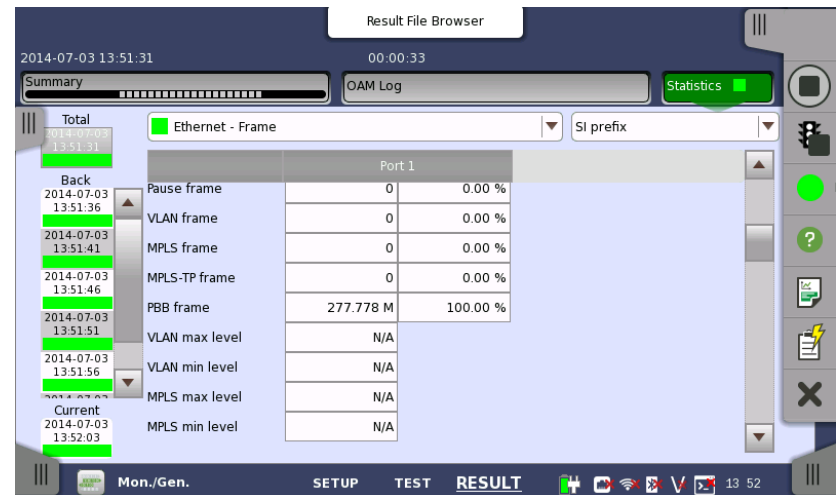
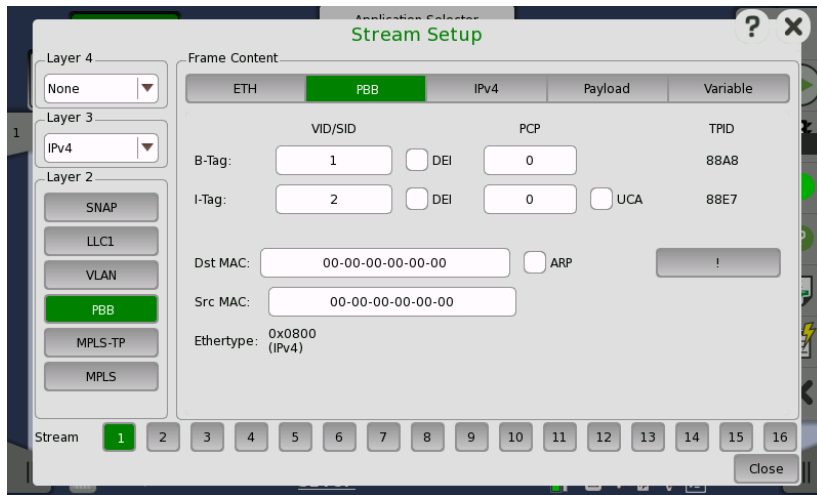

# MT1000A TCP Function

- Set TCP connections before sending traffic with TCP headers
  - Allows traffic to pass firewalls using “state-full inspection”
  - Limited implementation:  
For example:  
No retransmissions  
No flow control

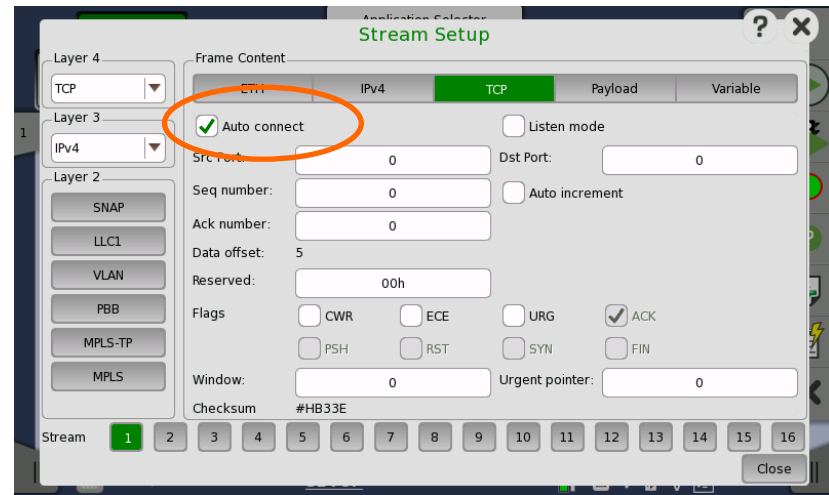

# MT1000A Ethernet Traffic Generator

- Ramp traffic: Increases traffic automatically until max. capacity exceeded
  - Programmable per stream
- Burst Traffic: Continuous sending at specified conditions
- Generate Tx rates above 100%
- Data type profiles (data, video, voice)

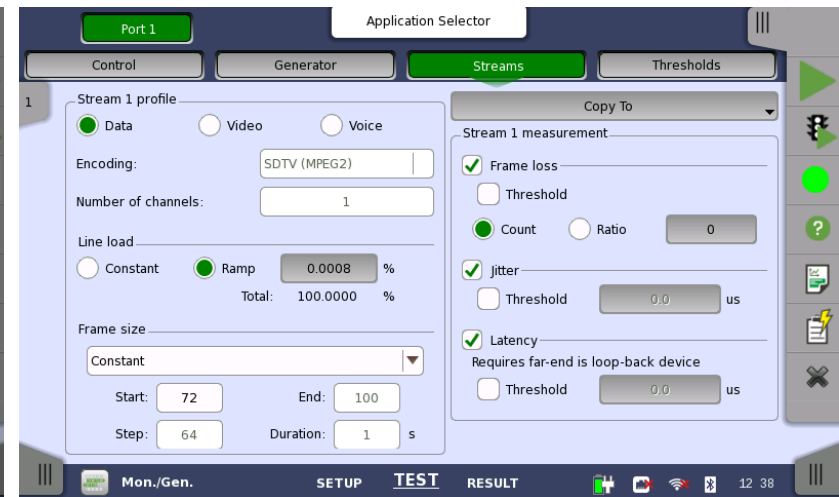
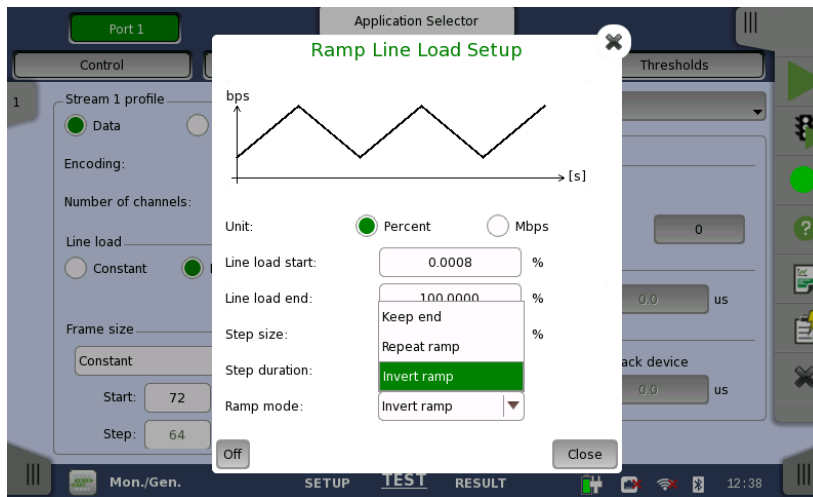

# Custom Editing of Ethernet Header

- Free editing of the Ethernet Header in the Frame stream settings to support special protocols for R&D.
  - This function can be used with the following applications:
    - Ethernet BERT Application

- ✓ Edit Custom header with text editor for Save and Load
- ✓ Supports Header lengths up to 256 bytes

- ◆ The following restrictions apply:
  - "Ethernet over OTN" not supported
  - Rx filters other than Layer 2 not supported when using Layer 3 Custom headers
  - No Rx filters supported when using Layer 2 Custom headers
  - Arp/Ping functions not supported when using Layer 2/3 Custom headers

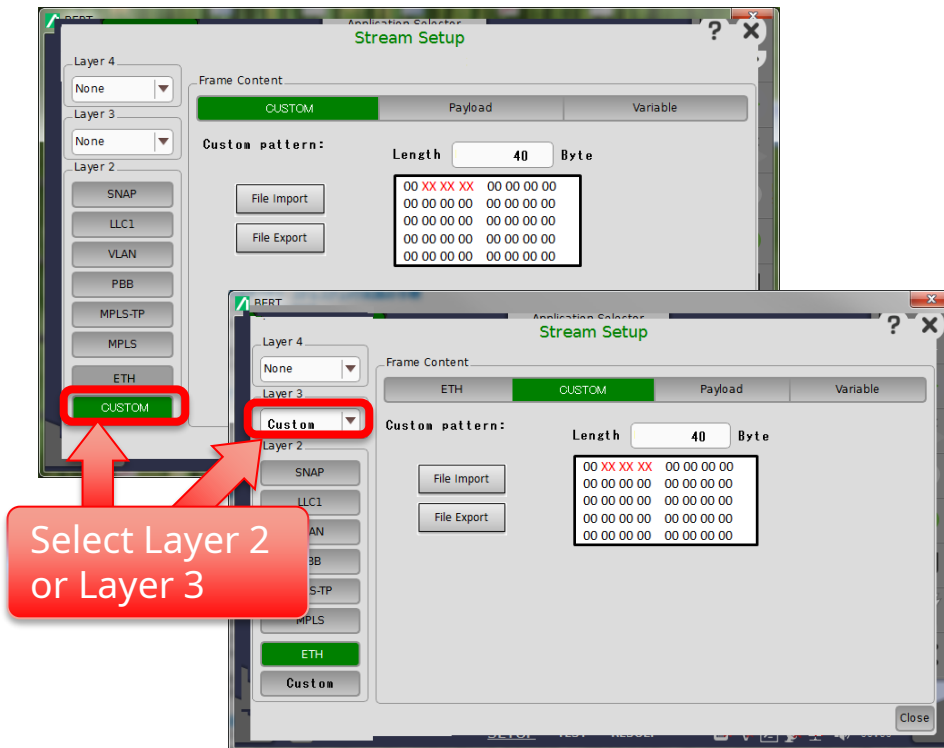

# MT1000A Ethernet Frame Capture Function

- Protocol analysis
  - For advanced Ethernet troubleshooting
  - Captures frames in live traffic of monitored line
  - Analyzes captured frames using Wireshark® protocol analysis software

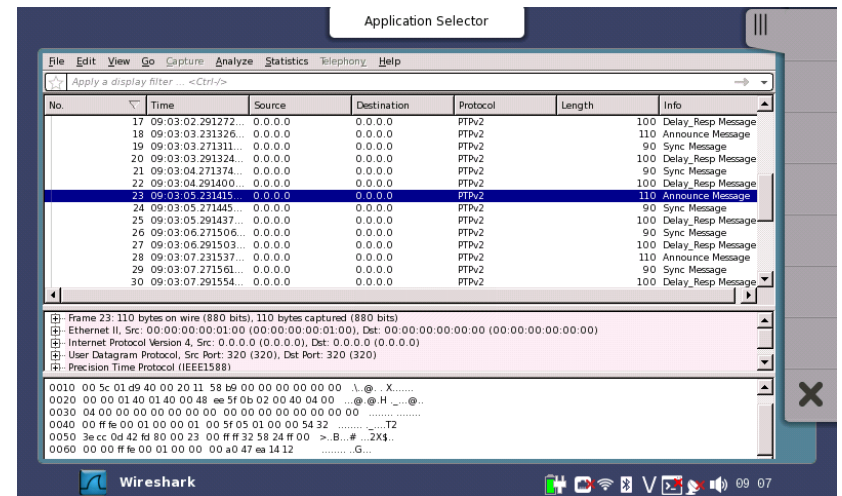
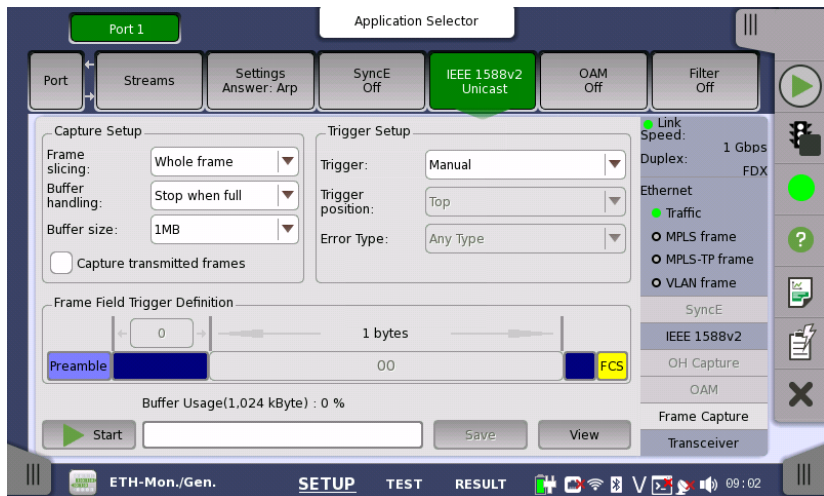





# Link Fault Signaling (LFS) Emulation

- Enables/disables LFS Emulation for MU100011A 10GbE and faster interfaces
  - When enabled
    - A) Sends RF when LF detected (LF Rx or Link down, etc.)
    - B) Sends Idle signal when RF detected during Tx streaming; sends stream when RF released



- When disabled (or using V9.11 or earlier)
  - Does not send RF when LF detected (LF Rx or Link down, etc.); Tx side unaffected
  - Tx side unaffected whether RF detected or not

Technology	Application	10GbE	25GbE	40GbE	100GbE
Ethernet *1	RFC2544	✓ □	✓	✓	✓
	SAT(Y1564)	✓	✓	✓	✓
	RFC6349	✓	-	-	-
	BERT	✓	✓	✓	✓
	Mon/Gen	✓	✓	✓	✓
	Pass Through		-	-	-
	Reflector	✓	✓	✓	✓
	Channel Stat	✓	-	-	-
	Ping	✓	✓	✓	✓
	Traceroute	✓	✓	✓	✓
	Sync Test	✓	✓	-	-
	Discovery				
	Mobile xHaul	eCPRI BERT	✓	✓	✓

✓ : Supported  
 - : Bit rate when application not supported  
 Blank: No supported

\*1: The LFS Emulation function does not operate at Mapping to OTN.

# Network Discovery and In-band Control

- No Need for Two Engineers for End-to-end Test
  - One engineer controls both local and remote testers without dedicated LAN for remote access
  - Testing from one end cuts OPEX
- Process
  - Discover other “Network Master(s)” on network
  - Remote-control far-end tests, such as RFC2544, Y.1564, Reflector (L2/L3/L4 loopback) etc.
  - Generate report at local controller with results summarized at both local and remote testers

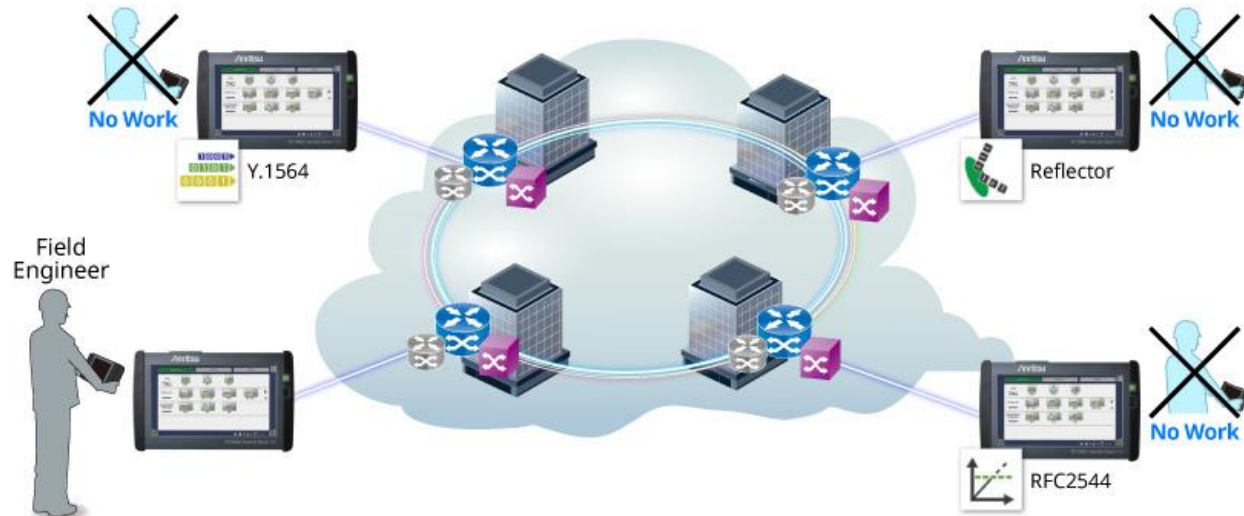

# Validating PCS at 10 GbE

- Validating PCS operation at the 10 GbE interface to support fast troubleshooting in the PCS layer:
  - Error/Alarm Insertion
  - Error/Alarm Display/Count
  - Native 10G LAN PHY is supported

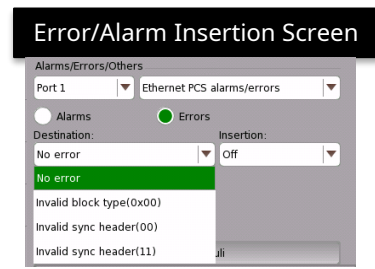
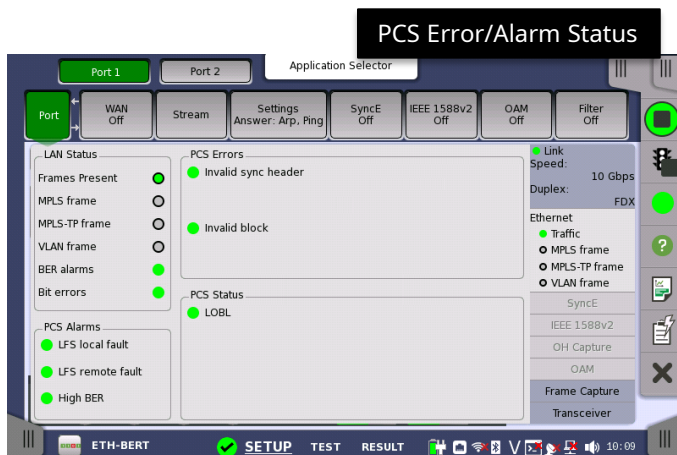
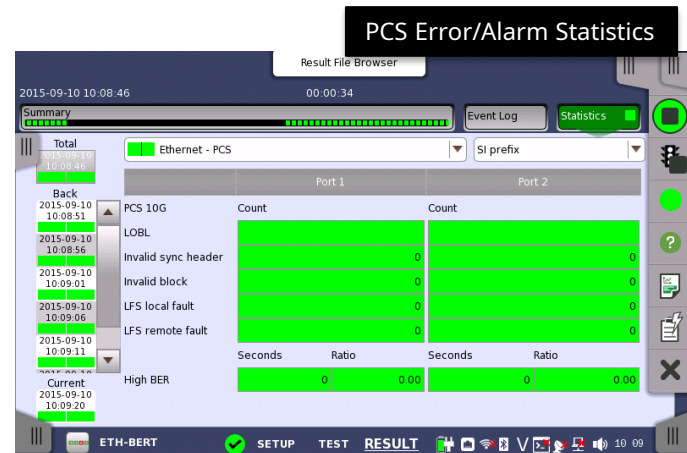

- Does not support Stimuli function Invalid alignment marker/BIP error

# 10G WAN PHY Background

- 10G WAN PHY
  - Mapping Ethernet frames to SONET/SDH

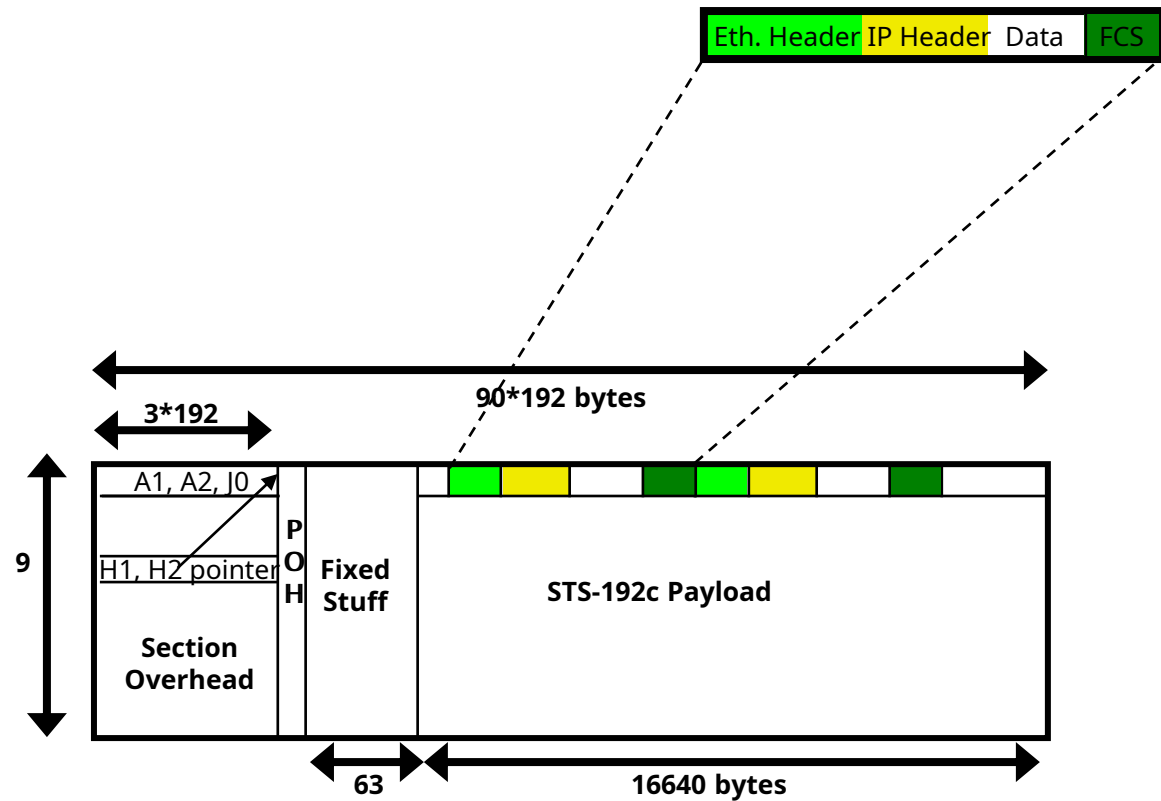

Fixed pointer in transmitted WAN signal; may have changed value when reaches destination

# MT1000A 10G WAN PHY Function

- WAN results
  - Bi-directional overhead byte capture (requires dual-port version)
  - Error and alarm statistics on WAN part of signal with Ethernet BERT application

The screenshot shows the 'Application Selector' interface for 'Port 1'. The 'WAN Sonet' application is selected. Below the application settings, there is a table for data capture. The table has columns for 'TOH' (Type of Header) and 'STS-3 POH' (Section 3 Path Overhead Header). The data is organized into frames (00-07, 08-15, 16-23, 24-31, 32-39, 40-47, 48-55, 56-63). The table shows various header types and their corresponding values, such as A1, A2, A3, A4, B1, B2, B3, B4, C1, C2, C3, C4, D1, D2, D3, D4, D5, D6, D7, D8, D9, D10, D11, D12, D13, D14, D15, D16, D17, D18, D19, D20, D21, D22, D23, D24, D25, D26, D27, D28, D29, D30, D31, D32, D33, D34, D35, D36, D37, D38, D39, D40, D41, D42, D43, D44, D45, D46, D47, D48, D49, D50, D51, D52, D53, D54, D55, D56, D57, D58, D59, D60, D61, D62, D63, D64, D65, D66, D67, D68, D69, D70, D71, D72, D73, D74, D75, D76, D77, D78, D79, D80, D81, D82, D83, D84, D85, D86, D87, D88, D89, D90, D91, D92, D93, D94, D95, D96, D97, D98, D99, D100.

The screenshot shows the 'Result File Browser' interface for 'Port 1'. The 'Ethernet - WAN Alarms/Errors' section is selected. The interface displays a table of alarms and errors with columns for 'Alarms', 'Count', and 'Ratio'. The data is organized into frames (00-07, 08-15, 16-23, 24-31, 32-39, 40-47, 48-55, 56-63). The table shows various alarm types and their corresponding counts and ratios, such as LOS, LOP, OOF, TIM-S, AIS-L, RDI-L, AIS-P, LOP-P.

Alarms	Count	Ratio
LOS	0	0.00
LOF	0	0.00
OOF	0	0.00
TIM-S	0	0.00
AIS-L	0	0.00
RDI-L	0	0.00
AIS-P	0	0.00
LOP-P	0	0.00

# MT1000A 10G WAN PHY Function

- WAN overhead byte generation
  - User programming of transmitted OH bytes
  - SDH or SONET terminology

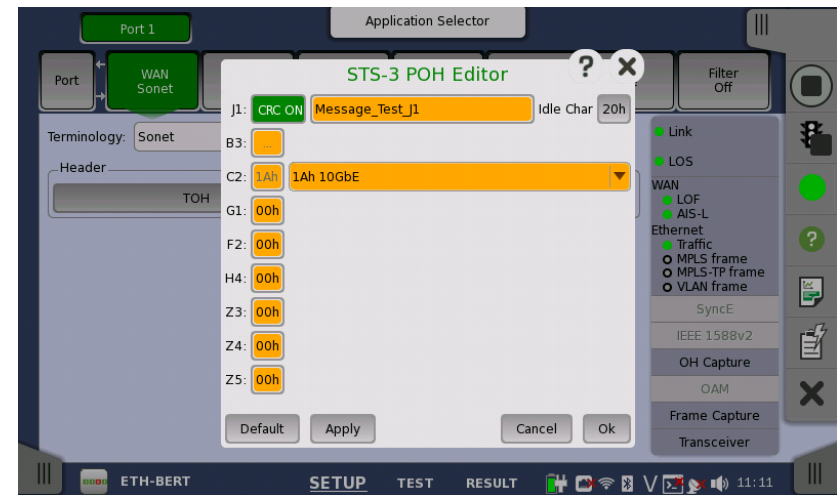
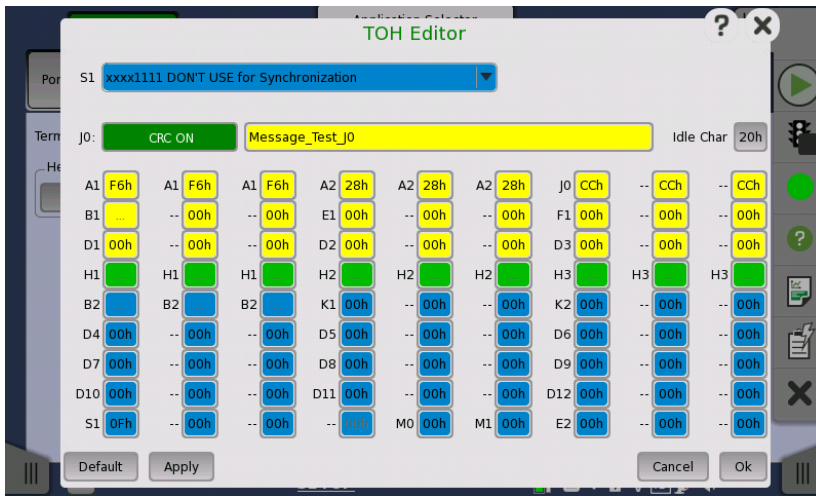

# Network Master Pro MT1000A

- TCP Throughput Option (RFC 6349) (Up to 10 Gbps)

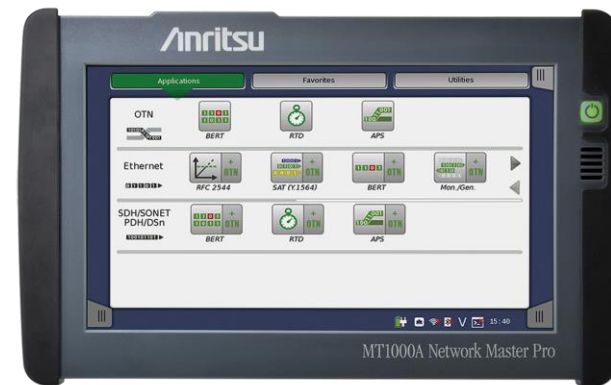

- Optimized performance essential in modern communication networks
- IP network operators can test networks based on IETF RFC 2544 and ITU-T Y.1564
  - Even when network seems fine at these tests, customers may complain that achieved throughput below agreement with operator
  - Can be caused by non-optimal configuration of Transmission Control Protocol (TCP) providing higher-layer connections through network, or badly configured network element burst size settings
- TCP adds reliability to communication over IP network because data receiver acknowledges packets received correctly
  - To support this, network elements have buffering
    - Data throughput reduced if buffering sizes incorrect
- Operators use RFC 6349 test methodology to optimize TCP throughput



# RFC 6349 Testing – Benefit of TCP Throughput Test

- Eliminate end-user factors from test by emulating TCP host  
Bi-directional TCP throughput test by emulating end user hosts



- MT1000A TCP throughput test hardware based
  - Always validate maximum TCP throughput potential possible on customer's network
  - Repeatable tests with consistent results
- MT1000A can perform bi-directional TCP throughput testing
  - More realistic test result
  - MT1000A can test up to four ports simultaneously
  - Can shorten multiple network commissioning test time

# RFC 6349 Testing – TCP Throughput Option (Up to 10 Gbps)

- TCP performance verification using RFC 6349 test methodology
- Client and server modes
- Connect to iPerf server as client
- Automated or manual testing
  - New installation mode
  - Troubleshooting mode
- Simultaneous bi-directional testing with independent settings
- Configuration of TCP Throughput (RFC 6349) test

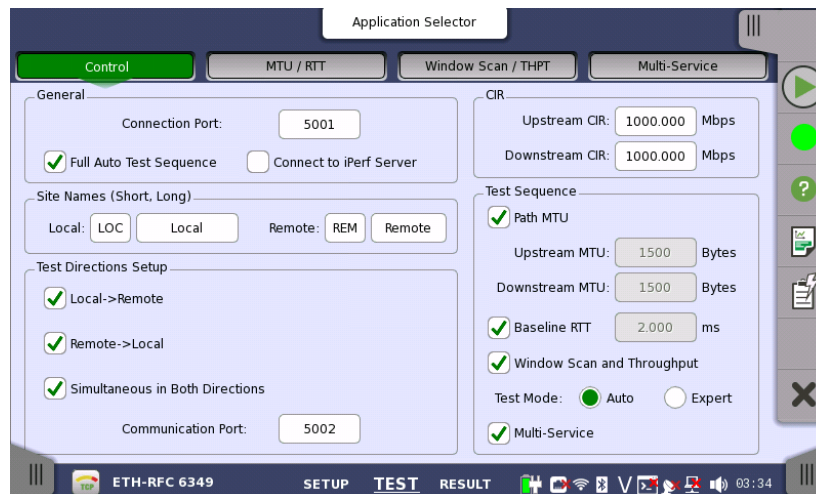

# RFC 6349 Testing – TCP Throughput Option (Up to 10 Gbps)

- Measurements include:
  - MTU (Maximum Transmission Unit) based on RFC 4821
  - RTT (Round-Trip Time)
  - Window scan
  - Throughput
  - Multi-service (if selected)

- Measurement results include:
  - Transmitted and Retransmitted Bytes
  - TCP Transfer Time Ratio
  - TCP Efficiency
  - Retrasmitted Percentage
  - Buffer Delay Percentage

2015-04-20 23:11:31 | 2015-04-20 23:15:09

Summary | Window Scan | Throughput | Multi-Service | Event Log | Statistics

**Local->Remote**

Window Size	Connections	Threshold	Avg Throughput	Avg RTT
2920 Bytes	1	95.00 % of Ideal	949.284 Mbps	0.022 ms

Network Parameters	Source	Value	RFC6349 Metrics	Result
MTU / MSS	Measured	1500 / 1460 Bytes	Transfer Time Ratio	1.00
RTT	Measured	0.022 ms	TCP Efficiency	100.00 %
CIR	User Input	1000.000 Mbps	Buffer Delay	0.00 %

ETH-RFC 6349 | SETUP | TEST | RESULT | 23 27

2015-04-20 23:11:31 | 2015-04-20 23:15:09

Summary | Window Scan | Throughput | Multi-Service | Event Log | Statistics

**Local->Remote**

Avg Throughput	Window Size/Conn
949.284 Mbps	2920 Bytes / 1
Ideal Throughput	Transmitted Bytes
949.285 Mbps	1.11 GB
Actual Transfer Time	Retransmitted Bytes
10.00 s	0 Bytes
Ideal Transfer Time	Retransmitted %
10.00 s	0.00 %
Transfer Time Ratio	TCP Efficiency
1.00	100.00 %

Baseline RTT	Min RTT	Avg RTT	Max RTT	Buffer Delay
0.022 ms	0.015 ms	0.022 ms	0.023 ms	0.00 %

ETH-RFC 6349 | SETUP | TEST | RESULT | 23 27

- Multi-service results (when selected)
  - Test up to 16 connections

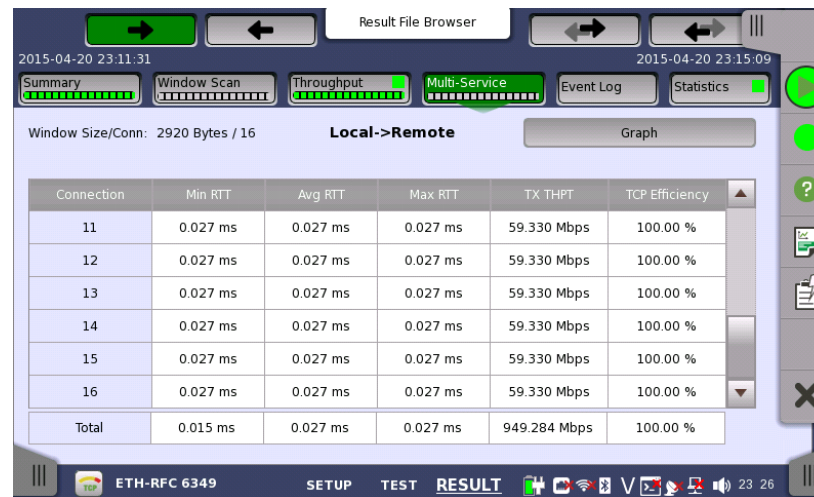

- Window Scan Result
  - MT1000A runs “Window Scan” test measuring TCP Throughput at each window size

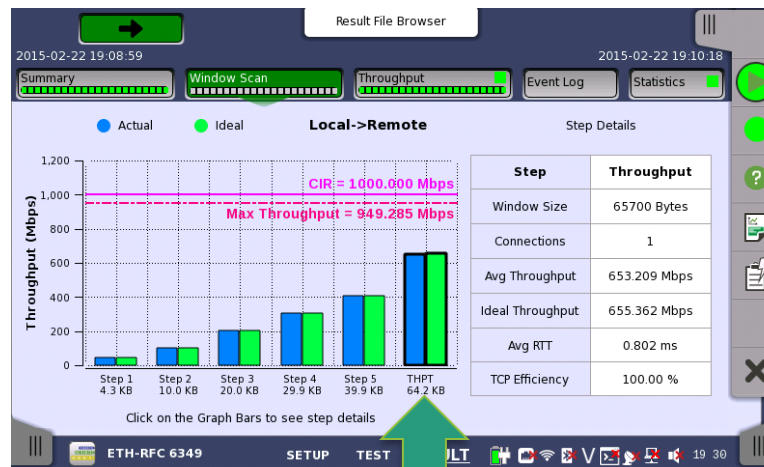

Optimum window size

$$\text{TCP Transfer Time Ratio} = \frac{\text{Actual TCP Transfer Time}}{\text{Ideal TCP Transfer Time}}$$

$$\text{TCP Efficiency \%} = \frac{\text{Transmitted Bytes} - \text{Retransmitted Bytes}}{\text{Transmitted Bytes}} \times 100$$

$$\text{Buffer Delay \%} = \frac{\text{Average RTT during transfer} - \text{Baseline RTT}}{\text{Baseline RTT}} \times 100$$

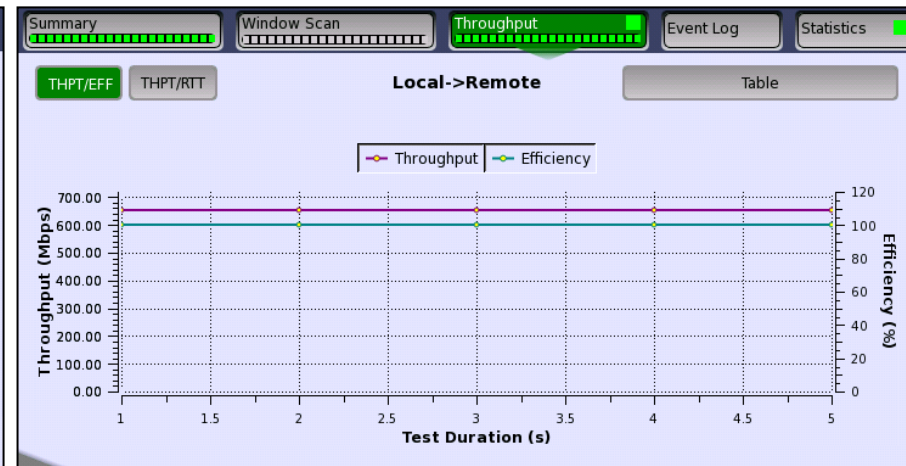
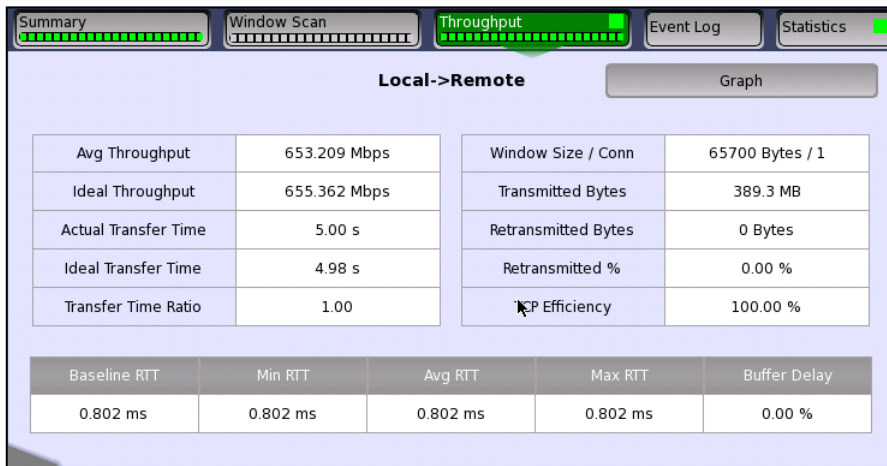

# Network Master Pro MT1000A

- Ethernet OAM Functionality

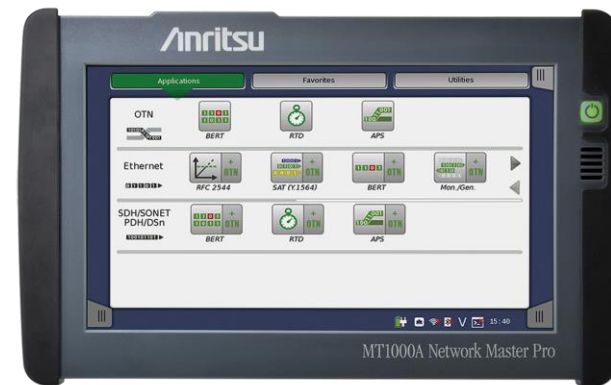

# Ethernet OAM background

- Ethernet moved from LAN technology to Carrier Class technology
- Ethernet Operations, Administration and Maintenance (OAM) developed to:
  - Ease operations, administration, and maintenance of complex Ethernet networks
  - Reduce operational expenses
- Ethernet OAM covers:
  - Link fault management
  - Connectivity fault management
  - Performance monitoring



# Ethernet OAM Layers

OAM layers	Functions	Standards
Transport layer	Ensures bi-directional communication between two directly connected devices Focuses on Ethernet First Mile (EFM) Link fault management	IEEE 802.3 (now includes IEEE 802.3ah)
Connectivity layer	Monitors path between two devices not directly connected Connectivity fault management incl. Link trace, continuity check and loopback protocols	IEEE 802.1ag ITU-T Y.1731
Service layer	Monitors status of services as seen by customer Performance monitoring including Frame Loss, Frame Delay and Throughput measurements	ITU-T Y.1731

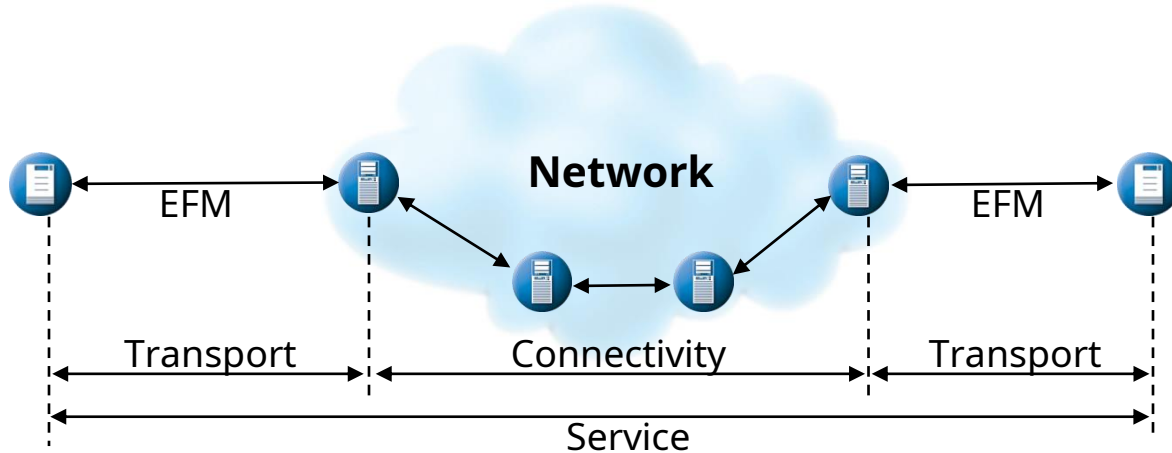

# Ethernet OAM Y.1731 and IEEE 802.1ag

- Y.1731 and IEEE 802.1ag similar
  - Supported by both Y.1731 and IEEE 802.1ag:
    - Connectivity fault management
  - Supported by Y.1731 only:
    - Performance monitoring
  - Same frame format for OAM PDUs (Protocol Data Units)



# Ethernet OAM IEEE 802.3ah

- Ethernet OAM IEEE 802.3ah functions:
  - Remote failure indication during fault
  - Remote loopback mode (“Real” loopback)
  - Fault isolation
  - Link performance and status monitoring
  - OAM discovery mechanism
    - Determines whether remote device has OAM enabled and configured parameters and supported functions compatible with requesting device
  - Optional activation of OAM
    - OAM can be enabled on ports subset or all ports
  - Extension mechanism
    - Available for higher-level management applications

# Ethernet OAM

- Ethernet OAM Y.1731 set-up and results:

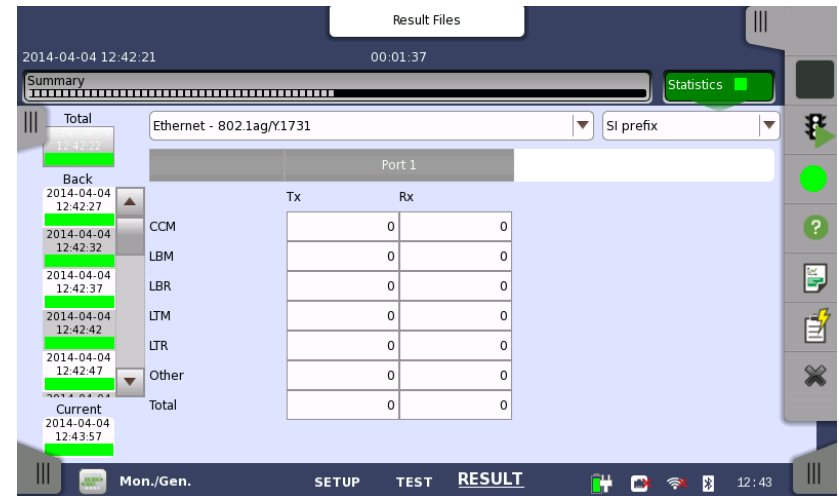
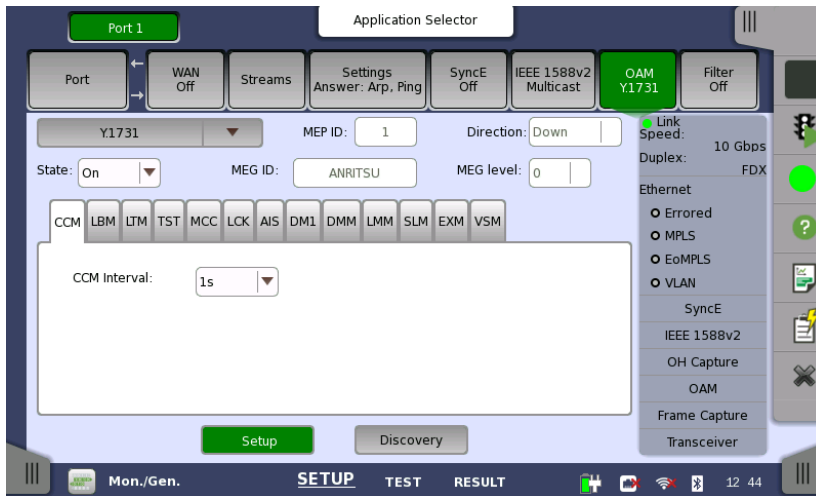

# Network Master Pro MT1000A

- Mobile Backhaul Installation and Verification
  - Synchronous Ethernet Test
  - Phase/Time Synchronization Test

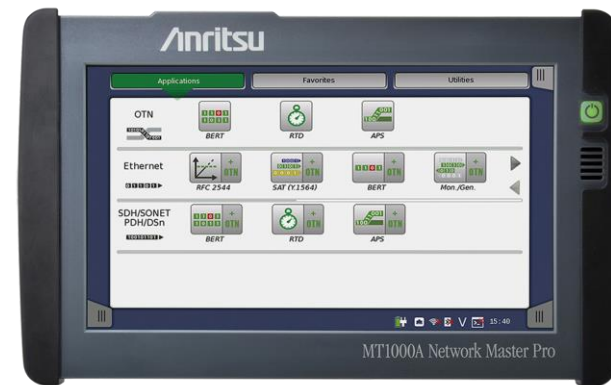

- Recently Ethernet become dominant technology for data transmission, due to simplicity and low cost
  - Started as LAN (Local Area Network) technology but now used for end-to-end communications
- Synchronous networks (PDH, SDH/SONET) migrating to Ethernet-based packet-switched network (PSN) are used for Mobile Backhaul network (MBH).
- Asynchronous nature of Ethernet causes challenges:
  - Mobile networks have strong requirement for frequency synchronization across entire network
  - TDD and LTE-Advanced technology pushes requirement for phase/time synchronization to the Ethernet-based MBH.

- Synchronization can be applied to Ethernet-based packet networks using Synchronous Ethernet
- Techniques under consideration for Ethernet synchronization are:
  - Physical synchronization signal forwarding as defined in ITU-T recommendations G.8261, G.8262 and G.8264 (in many cases now called SyncE)
  - Packet-based synchronization as defined in IEEE1588 v2 Precision Time Protocol (PTP)
    - ITU-T G.8265.1 telecom profile for frequency synchronization
    - ITU-T G.8275.1 telecom profile for phase/time synchronization



- SyncE (ITU-T G.826x) functions:
  - Detect ESMC messages and real time display of received SSM/QL byte
  - Record ESMC message log
  - Generate alarm when SSM/QL not received within 5 seconds
    - Clear alarm on SSM/QL reception
  - Transmit ESMC/SSM messages with user-defined QL
    - Four user-selectable QL interpretations
  - SyncE recovered frequency monitor and synchronized packet generation.

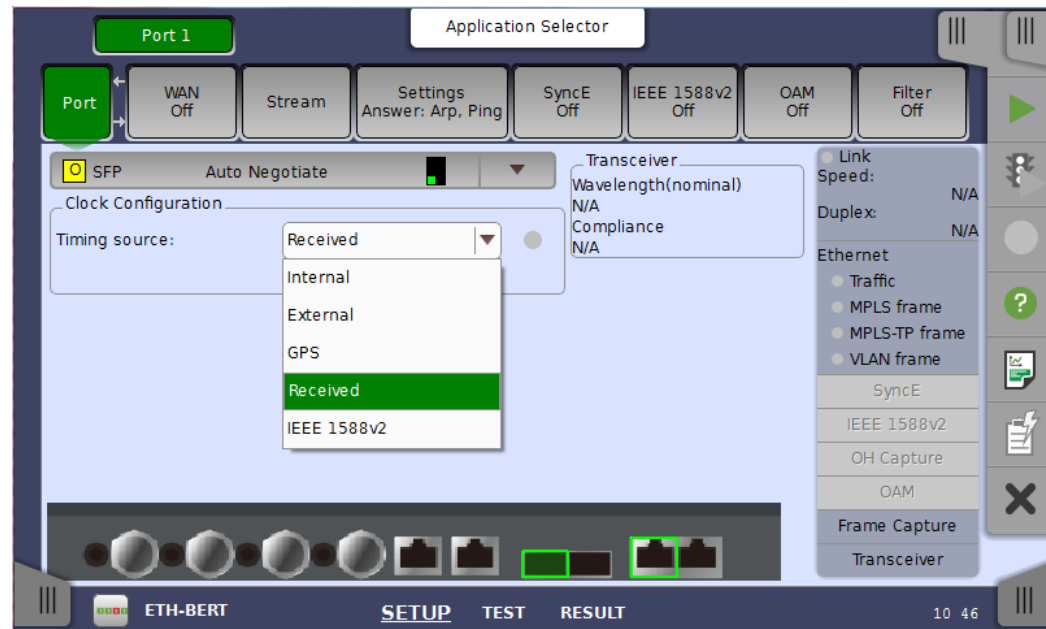



- Protocol Parameter G.8265.1 / G.8275.1 / G.8275.2
  - MT1100A Supports G.8265.1, G.8275.1 G.8275.2 and “Custom” profile

Parameters	G.8265.1	G.8275.1	G.8275.2
Purpose	Frequency	Frequency and Phase	Frequency and Phase
Protocol Stack	UDP/IP(v4/v6)/Ethernet	PTP/Ethernet (w/o VLAN)	UDP/IP(v4/v6)/Ethernet
Addressing	Unicast	Multicast	Unicast
Unicast negotiation	Yes	No	Yes
Timing Transfer Method	One-way or Two-way	Two-way	One-way or Two-way
Clock Behavior	One-step or Two-step	One-step or Two-step	One-step or Two-step
Path delay mechanism	End-to-end	End-to-end	End-to-end
Domain No.	4 to 23	24 to 43	44 to 63
Priority 1 range / Priority 2 range	- / -	128 / 0 to 255	128 / 0 to 255
Class	80 to 110	6,7,135,140,150,160,165,248,255	6,7,135,140,150,160,165,248,255
BMCA	Static BMCA	Alternative BMCA	Alternative BMCA
Message interval of Sync	1/128 to 16	1/16	1/128 to 1
Message interval of Delay Request	1/128 to 16	1/16	1/128 to 1
Message interval of Announce	1/8 to 16	1/8	1/8 to 1
Announce timeout	2	3 to 10	2

- SyncE (ITU-T G.826x) results (per port):
  - Status information:
    - Rx SSM QL (current value)
  - Statistics on SSM QL messages and values

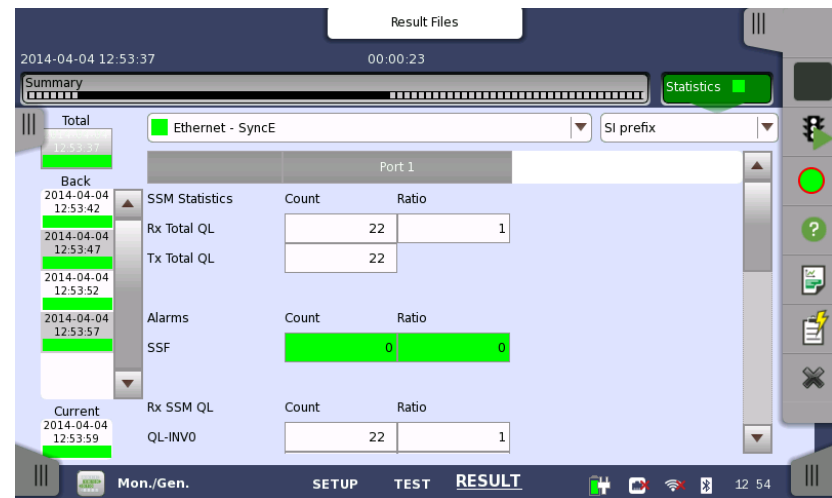
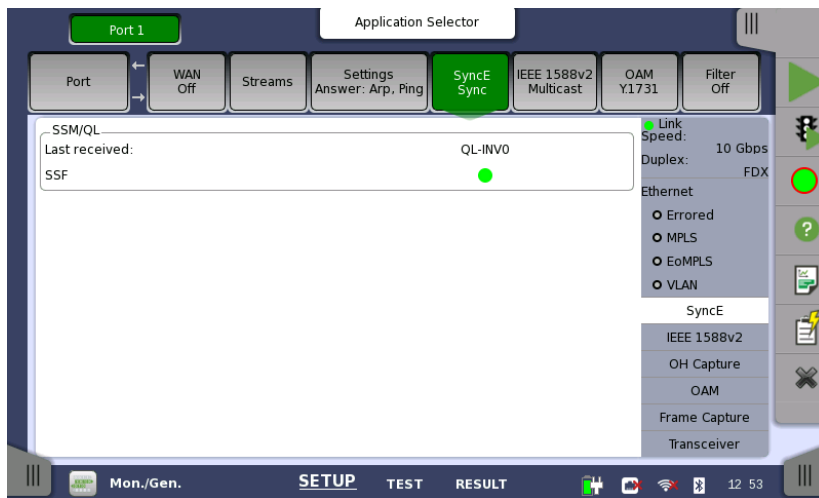

- IEEE 1588 v2 (PTP) functions:
  - Support G.8265.1, G.8275.1 and G.8275.2 profile and 'User defined' one.
  - Emulating a master clock.
    - Selectable UTC source from internal instrument clock or GPS.
    - Configurable parameters of Announce message, etc.
  - Emulating slave clock
    - Configurable parameters of message interval, etc.
    - Best master clock algorithm (BMC)
  - Supported encapsulations: PTP-UDP-IP(IPv4 and IPv6) and PTP-MAC
  - Support stacked VLAN and MPLS
  - Real time PTP signaling sequence in ladder chart, off-line analysis by PCAP file capture, message statistics, message rate measurement.



For quick analysis and troubleshooting of IEEE 1588 v2 (PTP) signaling

- IEEE 1588 v2 (PTP) results – statistics on:
  - Offset and offset variance
  - Path Delay Variation (PDV)
  - Messages
  - Clock state transitions

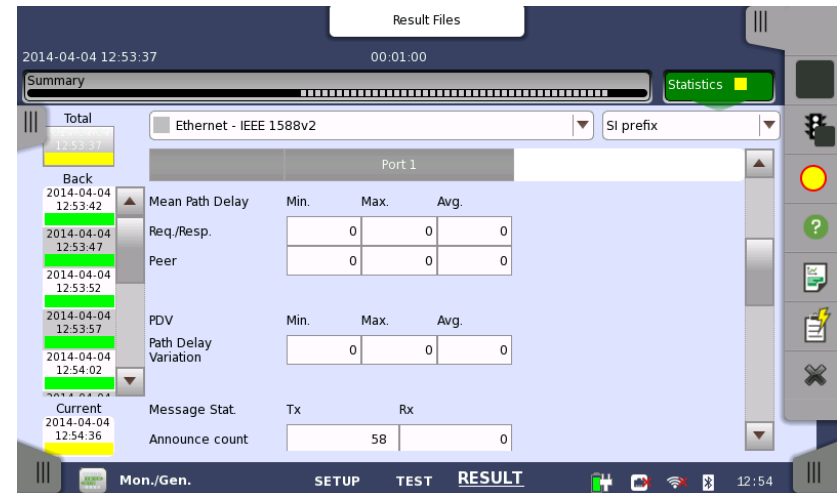
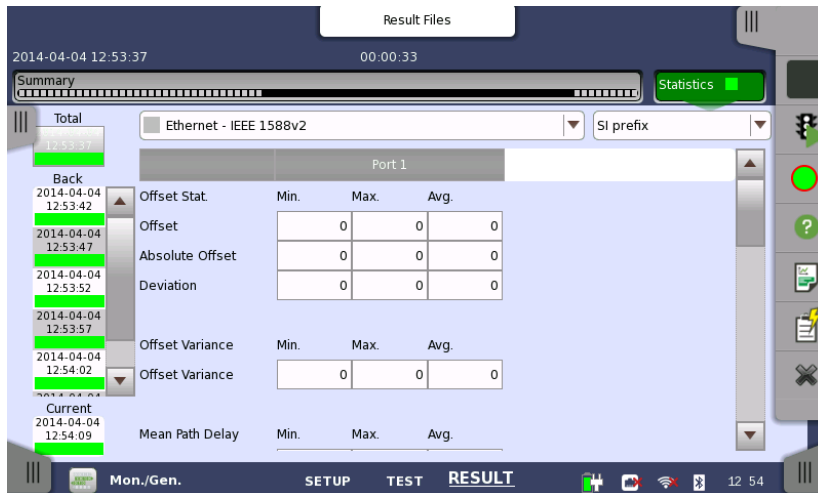

- IEEE 1588 v2 (PTP) clock status real time information

The screenshot shows the 'Application Selector' interface for 'Port 1:1'. The 'IEEE 1588v2 Unicast' option is selected and highlighted in green. The interface is divided into several sections:

- Local Clock:** State: N/A, Offset: N/A, Mean path delay: N/A, Sync timeout:
- Parent Clock:** Identity, Port number: N/A
- Foreign Master:** 00:00:00:00:00:00:00:00, Port number, Announce count
- Wall Clock:** UTC, Current, UTC offset
- Grandmaster Clock (highlighted in red):**
  - Identity
  - Class
  - Accuracy: User defined (0x0)
  - Variance ann/est.: N/A / N/A
  - Variance Raw: 0x0000
  - Priority 1/2: N/A / N/A
  - Steps removed: 0x00
  - Time source: User defined (0x00)
  - UTC offset: N/A
  - flagField: 0x0000
- Right Panel:** Link Speed: N/A, Duplex: N/A, Ethernet (Traffic, MPLS frame, MPLS-TP frame, VLAN frame), SyncE, IEEE 1588v2, OH Capture, OAM, Frame Capture, Transceiver

# Phase/Time Synchronization Test

(Up to 25 Gbps)

- CDMA2000 and W-CDMA(TDD) require not only frequency synchronization but also phase/time synchronization among base stations. GPS has been used for that purpose.
- Expanding small cell deployment and technologies of LTE-TDD and LTE-Advanced cause increasing demands for packet-based phase/time synchronization by IEEE1588v2.
- New testing demands for mobile network installation and maintenance using IEEE1588v2 are rapidly increasing.

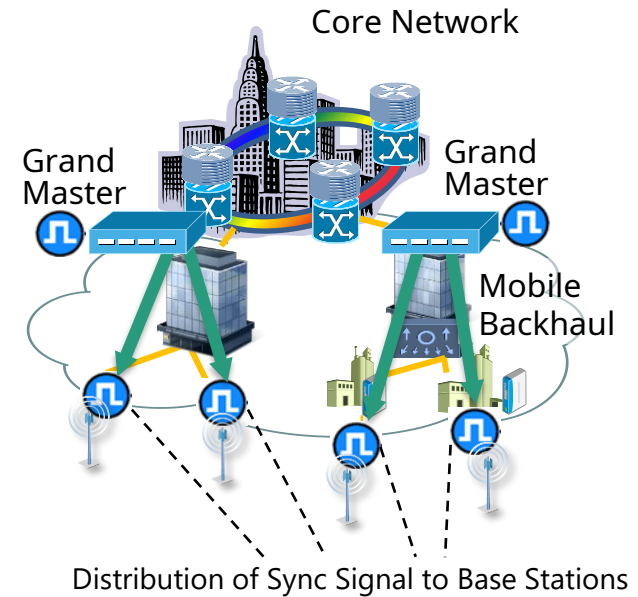

Application	Mobile Backhaul		Air Interface	
	Frequency	Phase	Frequency	Phase
LTE FDD	±16ppb	N/A	±50ppb	N/A
LTE TDD (large cell)		±1.1µs		±5µs
LTE TDD (small cell)		±1.1µs		±1.5µs
LTE-A MBSFN		±1.1µs		±1 to 5µs
LTE-A CoMP		±500ns to 1.1µs		±500ns to 5µs
LTE-A eICIC		±1.1µs		±1 to 5µs

Synchronization requirement to MBH

# Phase/Time Synchronization Test

(Up to 25 Gbps)

- MT1000A is located at the service demarcation point between mobile backhaul and mobile service. It evaluates SLA of the backhaul.
- MT1000A measures  $\max|TE|$ , cTE(Constant Time Error) and dTE(Dynamic Time Error) as metrics of phase/time synchronization.
- Supports GbE, 10GbE and 25GbE optical interfaces.

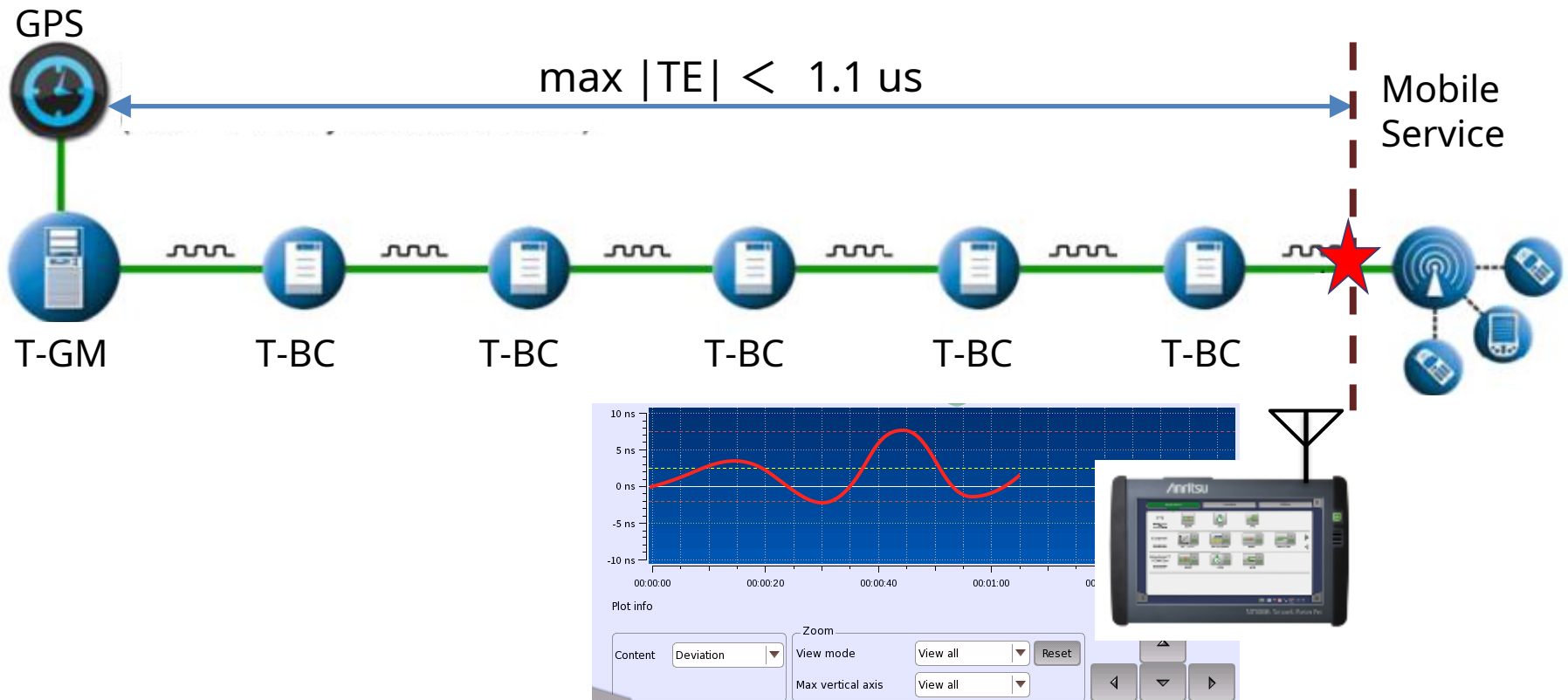

# Phase/Time Synchronization Test

(Up to 25 Gbps)

- Time Error method No.1: 1PPS Signal phase measurement  
Measuring the phase difference between the reference in the tester and 1PPS signal from the network under test.

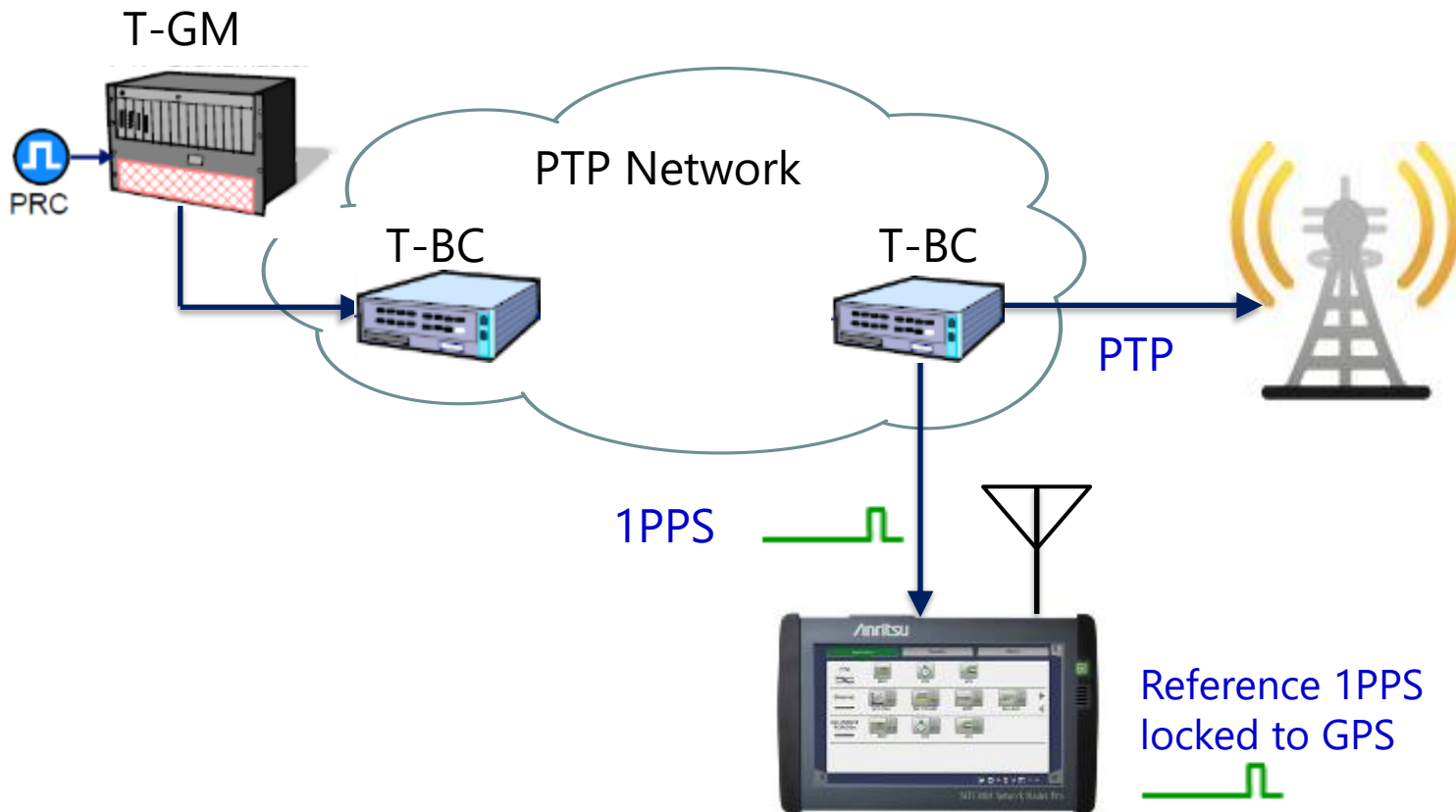



# Phase/Time Synchronization Test

(Up to 25 Gbps)

- Time Error method No.2: By PTP timestamp (defined in ITU-T G.8273)
  - The tester emulates slave clock and has reference UTC from GPS.
  - The tester measures the difference between the timing of PTP message reception and the time stamp inside the message (T1 and T4). This is observed as OWD(One-Way-Delay) .
  - Because cable length is known the tester estimates the time error by deducting the cable delay from the OWD.

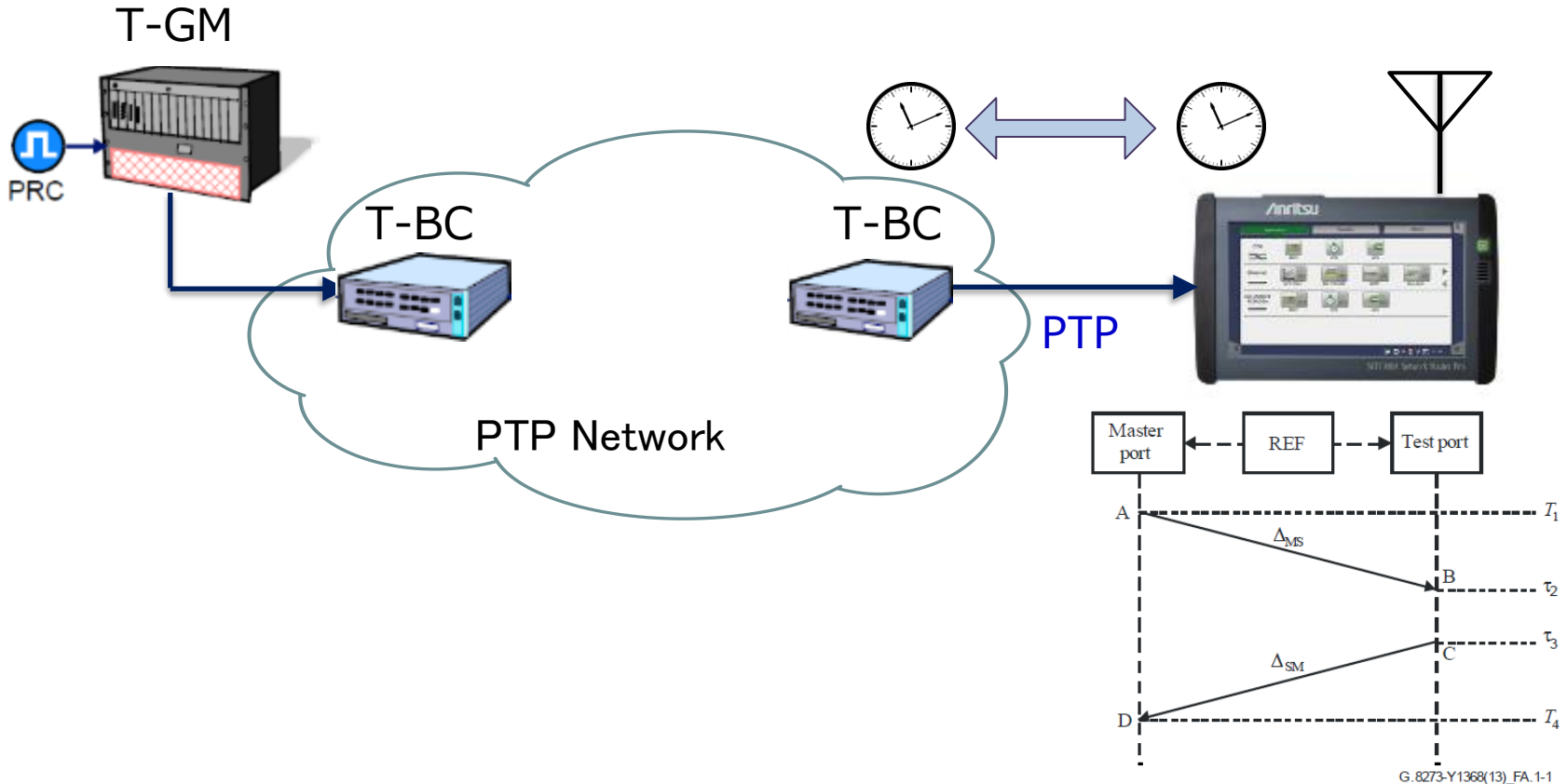

# Phase/Time Synchronization Test

(Up to 25 Gbps)

- MU100090B High Performance GNSS Disciplined Oscillator is required for phase/time synchronization test.

*1PPS output locked to GPS*

*GPS antenna is connected here*

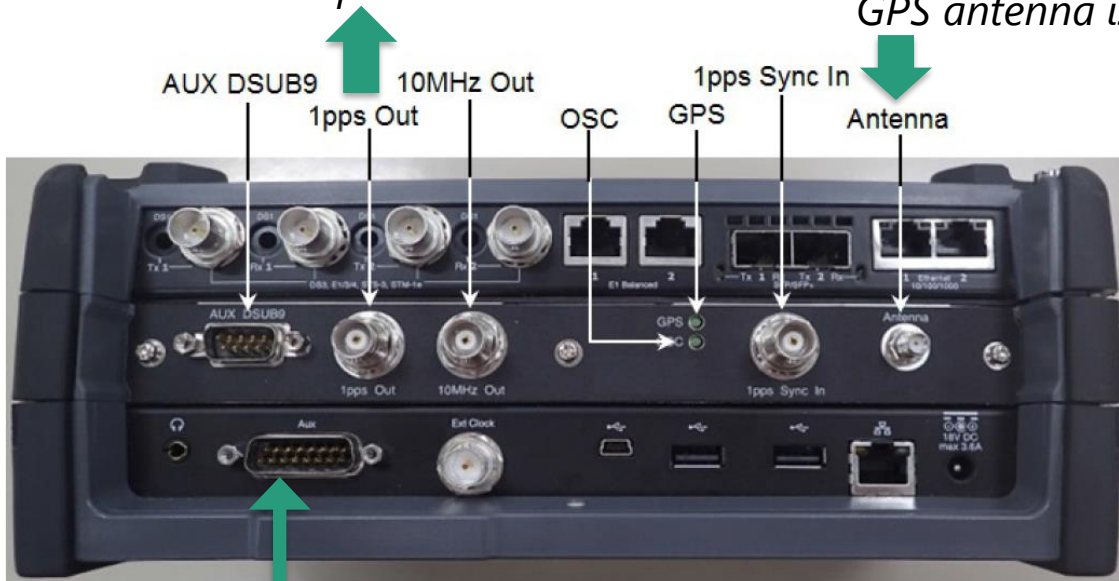

MU100090B

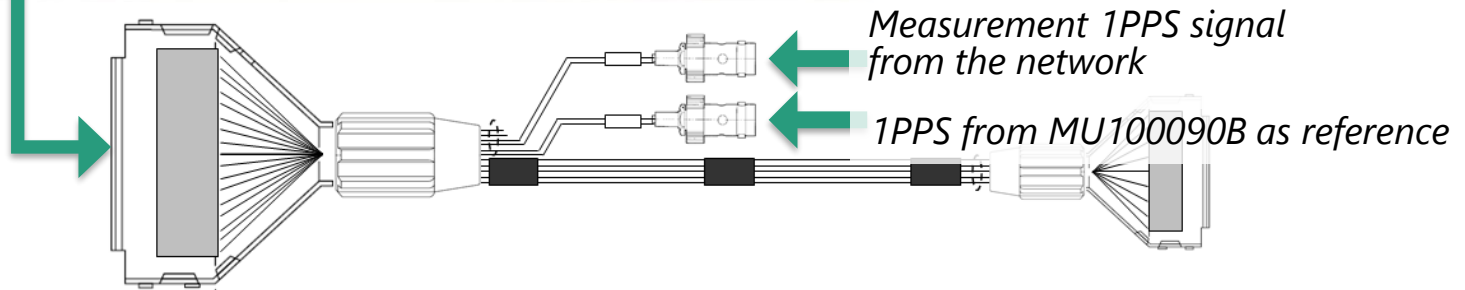

# Network Master Pro MT1000A

- Mobile Fronthaul Installation and Verification
  - CPRI/OBSAI Test
  - eCPRI/IEEE 1914.3

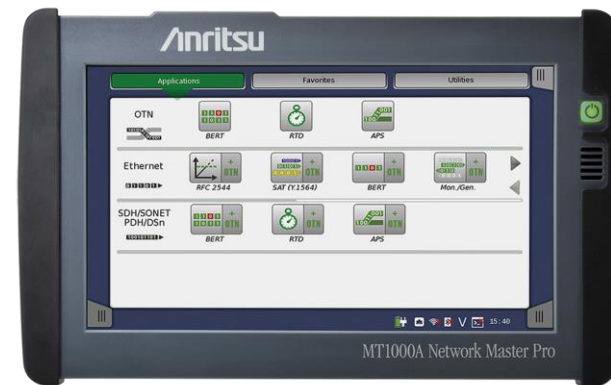

# CPRI Background

- Operators supporting explosive spread of smartphones and tablets by increasing bandwidth of mobile communications networks
- Driving complete change in mobile communications systems
  - Adoption of Centralized-Radio Access Networks (C-RAN).
    - Using C-RAN, the mobile fronthaul is configured from centralized Base Band Units (BBU) and multiple Remote Radio Head (RRH) units connected via general-purpose interfaces, such as the Common Public Radio Interface (CPRI) or Open Base Station Architecture Initiative (OBSAI).

# CPRI Bit Rates

- CPRI bit rates are referred to as "option #"
- There are now eight options (CPRI Specification V7.0)
- MT1000A supports Option 8, 10.1376 Gbps, reflecting marketing requirement of supporting exploring mobile network bandwidth.
- MT1000A can perform simultaneous testing up to 2 ports to reduce commissioning testing time.

Option	Bit rate (Gbps)	Line Code	Support Module
1	0.6144	8B/10B	MU100010A/MU100011A
2	1.2288	8B/10B	MU100010A/MU100011A
3	2.4576	8B/10B	MU100010A/MU100011A
4	3.0720	8B/10B	MU100010A/MU100011A
5	4.9152	8B/10B	MU100010A/MU100011A
6	6.1440	8B/10B	MU100010A/MU100011A
7	9.8304	8B/10B	MU100010A/MU100011A
8	10.1376	64B/66B	MU100010A/MU100011A
9	12.1651	64B/66B	MU100011A
10	24.2302	64B/66B	MU100011A

# OBSAI Bit Rates

- Four OBSAI bit rates are defined.
- MT1000A supports 6.144 Gbps, reflecting marketing requirement of supporting exploring mobile network bandwidth.
- MT1000A can perform simultaneous testing up to 2 ports to reduce commissioning testing time.

Bit rate (Gbps)	Line Code	Support Module
0.768	8B/10B	MU100010A/MU100011A
1.536	8B/10B	MU100010A/MU100011A
3.072	8B/10B	MU100010A/MU100011A
6.144	8B/10B	MU100010A/MU100011A

# C-RAN Market

- Market requirements

- Minimizing number of BBUs per antenna cuts operator costs (rent, power, HW, etc.)

Locating BBU 15 km or more from multiple RRH requires reliable connection i.e. C-RAN

- CPRI runs over C-RAN with two main layers:

- Layer 1: Physical transport
- Layer 2: Several areas

C-RAN main interest is L1 in-band protocol; understanding this area allows operator to troubleshoot alarms and errors

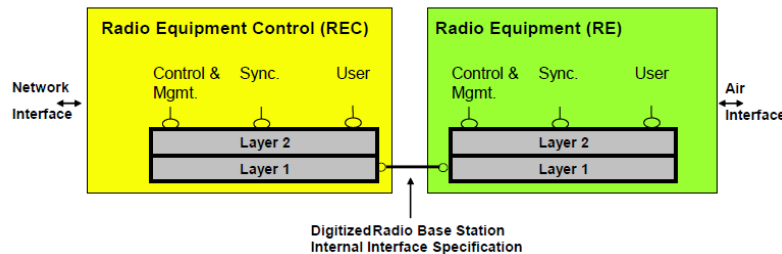

In CPRI, BBU is called REC, and RRH is called RE (Fig. 1 from CPRI Specification V6.0)

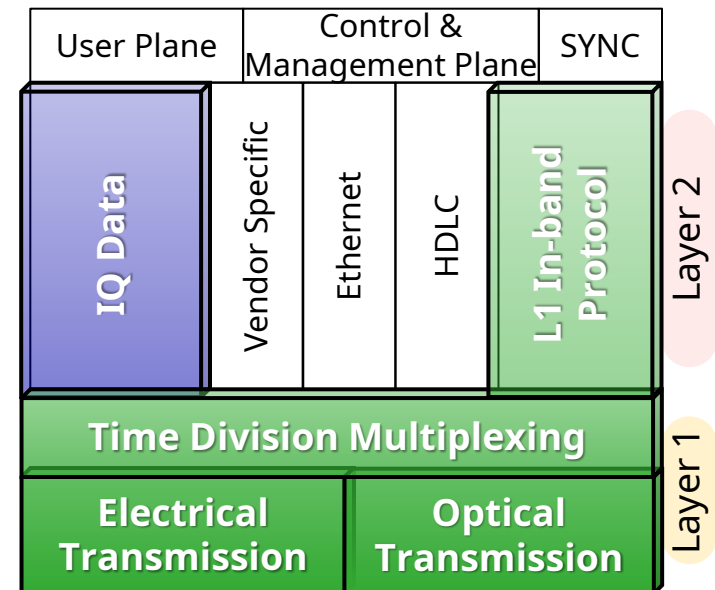

# CPRI/OBSAI - Test cases

- Test case 1
  - Test line between REC(s) and RE(s)
    - System testing
    - Installation testing
  - Line can be
    - Optical
    - Carried over radio link or microwave link
    - CPRI over OTN
    - Instrument connected via optical interface to link
  - Terminate both sides of transmission line
    - BER test (Framed or unframed) \*1
      - One side could be loopback
    - Delay measurement
      - With one side in loopback

## Test case 1



\*1: OBSAI supports UnFrame only



# CPRI/OBSAI - Test cases

- Test case 2

- CPRI Specification V7.0 defines
  - When both devices are in Operation state or in Passive link state, link is in normal operation
- Operators find that up to 80% of CPRI turn-up issues occur in lowest layers
- Essential during installation to: confirm RRH/RE can communicate to ground even without BBU/REC
  - Confirming RRH/RE can connect to Passive link state
  - Confirming HDLC layer (Layer 2) network is connecting
- Completing above minimizes chance of issues during BBU/REC installation

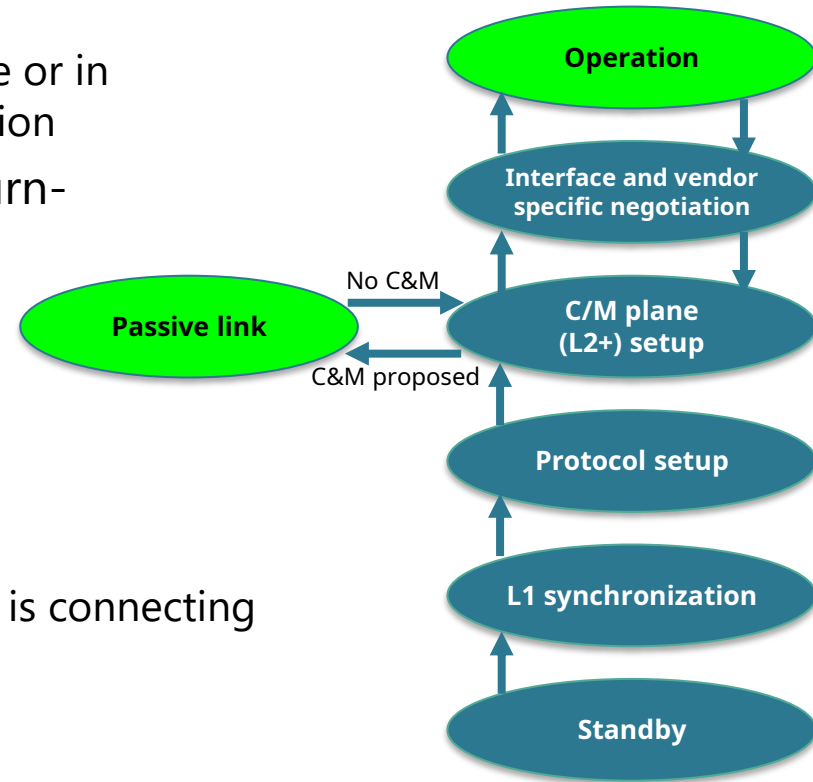

Extract from Figure 30 in CPRI Specification V7.0:  
Start-up states and transitions

# CPRI/OBSAI - Test cases

- Test case 2
  - Connect to actual equipment (REC or RE) to verify alive
    - Signal level and frequency measurement
      - Optical cable ends can be checked with Video Inspection Probe (VIP)
    - Monitor control word K30.7 – indicates error in 8B/10B line code (CPRI option 1-7 only) – and 8B/10B code violations
    - Check equipment behavior
      - Check that equipment can reach Passive link state
      - Confirm HDLC layer (Layer 2) network connecting
      - Check equipment behaviour at alarms

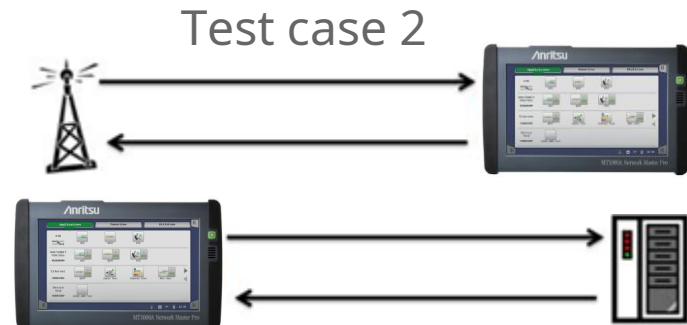

# CPRI/OBSAI - Test cases

- Test case 3
  - Monitoring actual line between REC (Radio Equipment Control) - (master) and RE (Radio Equipment) - (slave)
    - Using dual port in Pass-through mode or monitor
      - Monitor interactive behaviour of equipment
    - For maintenance or in-service troubleshooting

Test case 3

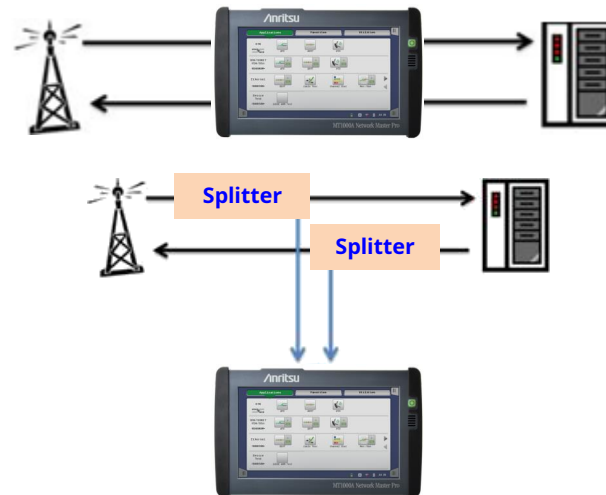

# MT1000A CPRI Wire Line Testing

- Supports CPRI interface rate option 1 (614.4 Mbit/s) to option 8 (10.1376 Gbit/s)
  - Ensures testing of current and future CPRI interfaces

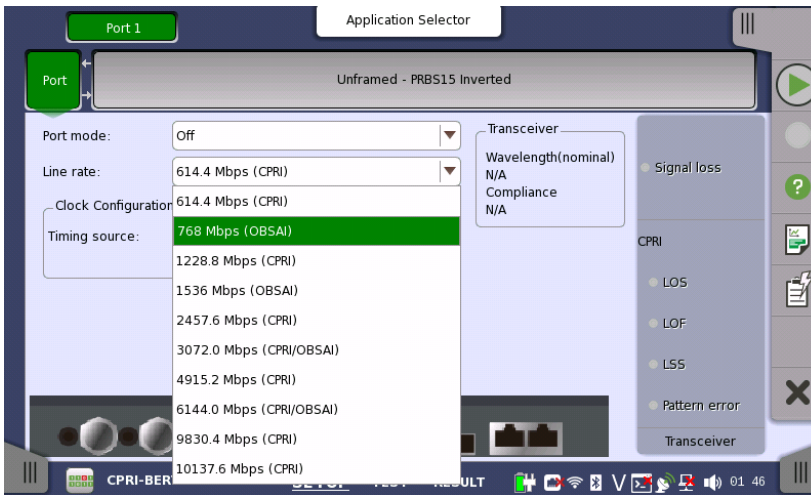

# MT1000A CPRI Wire Line Testing

- Testing at any rate
- Ability to exercise BBU or RRH up to Passive link status (as per latest CPRI standard)
- Support for Pass-through mode
  - Complete solution for detailed I&M testing

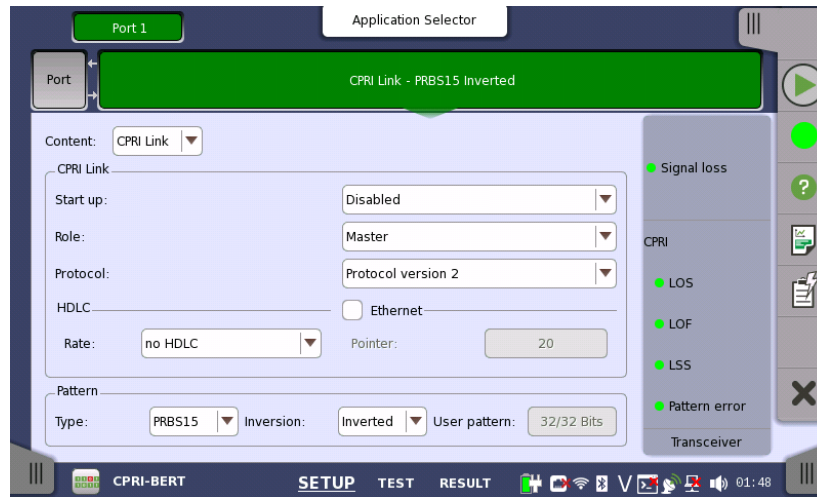

# MT1000A CPRI Wire Line Testing

- Displayed signal level and bit rate gives first verification of received-signal condition

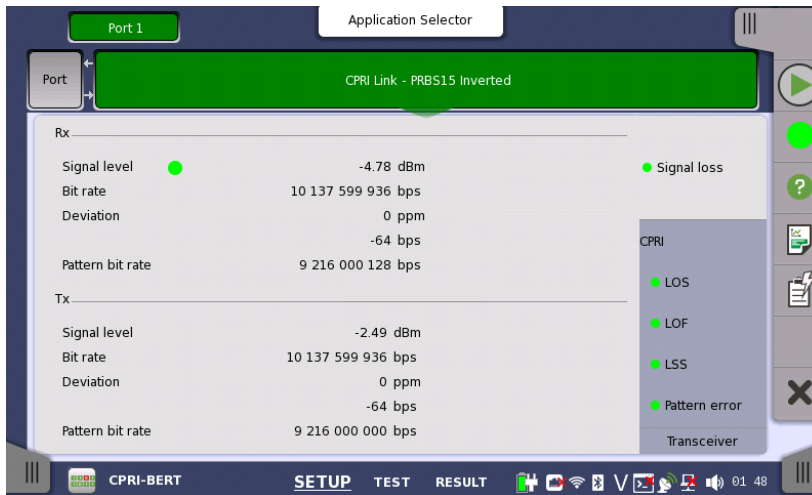

- Using Video Inspection Probe (VIP) to check fiber endface confirms quality practices and removes key cause of turn-up failure.

# MT1000A CPRI Wire Line Testing

- Checking for and inserting Layer-2 alarms and errors from BBU to RRH
  - Ensures engineer can complete advanced fault finding and evaluate issue root cause

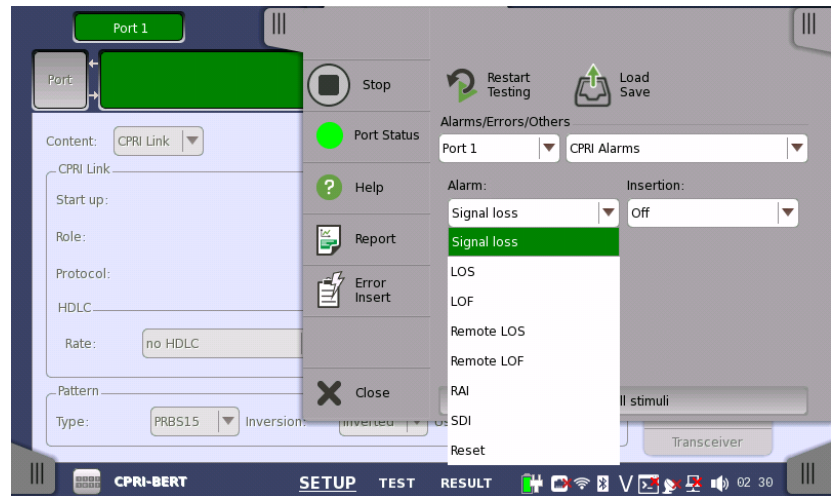
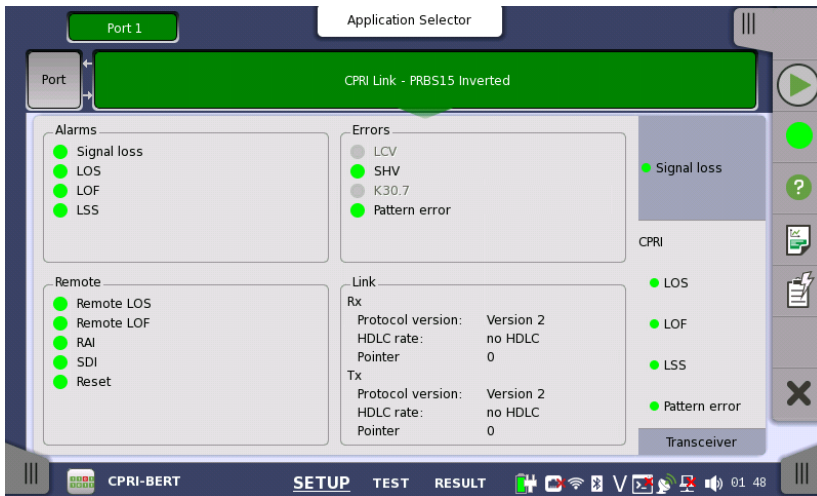

# MT1000A CPRI Wire Line Testing

- Test results:
  - Summary screen with pattern error information and survey of result pages
  - Alarms/Errors screen with details of detected CPRI alarms and errors
  - Color coding highlights detected alarms and errors

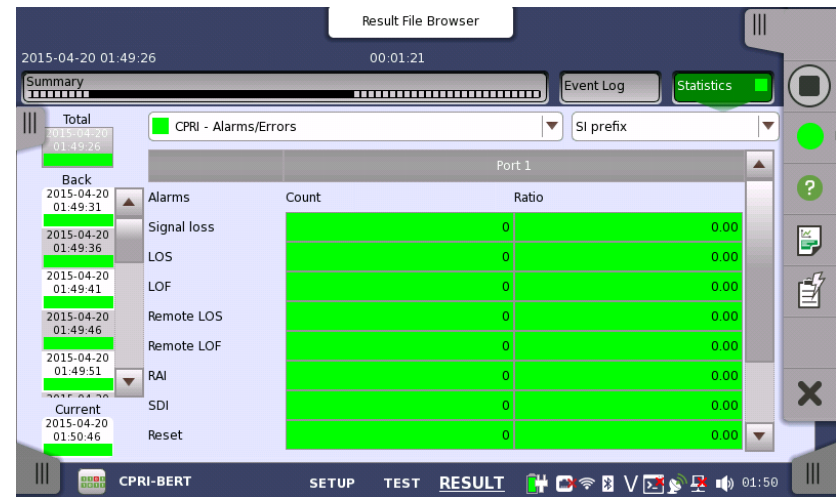
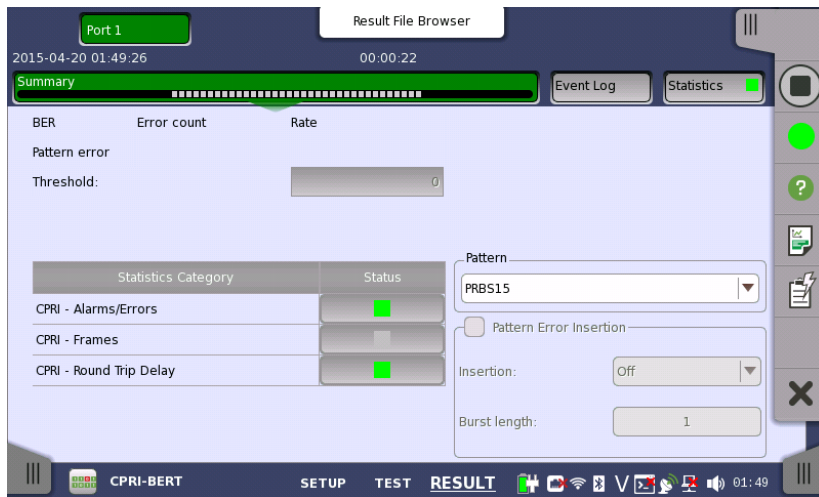



# MT1000A CPRI Wire Line Testing

- Test results:
  - CPRI Frames screen with counts of received and sent frames and code words
  - Delay screen showing measured Round Trip Delay

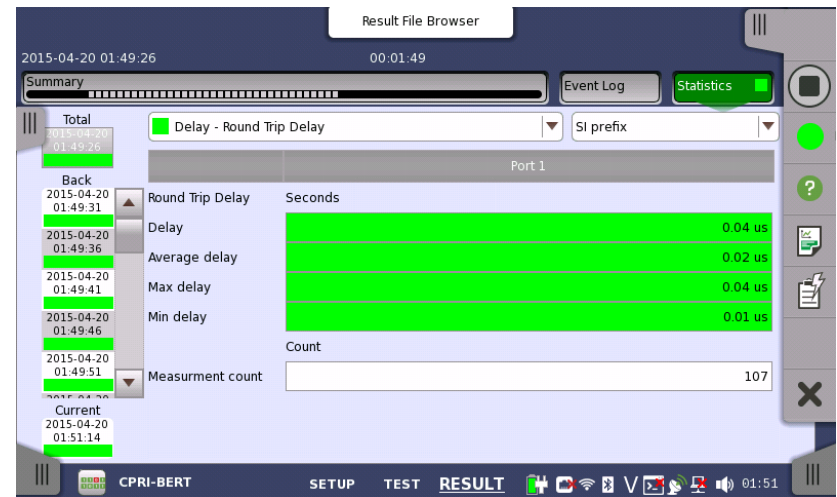
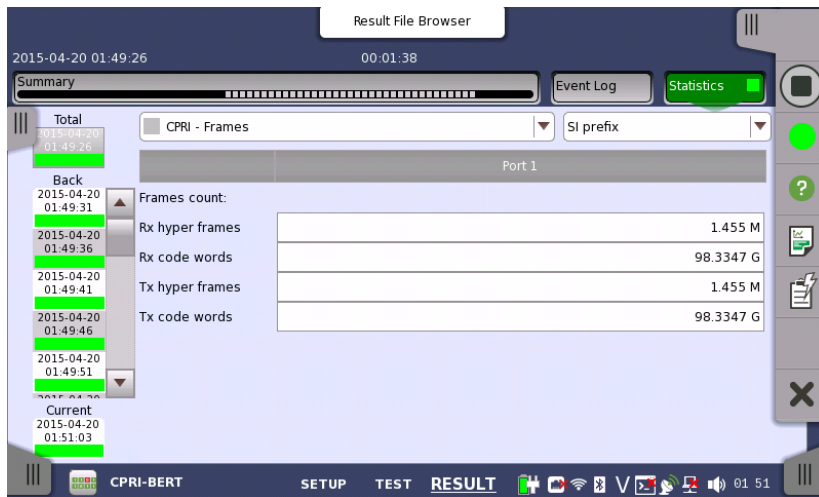

# MT1000A CPRI Wire Line Testing

- Added APS measurement function to CPRI BERT application
  - Sets any APS measurement start/stop trigger using checkbox, with APS measurement started/stopped at selected trigger OR condition
  - Choice of triggers for network configuration and hypothetical faults for analyzing how equipment and network perform at APS operation

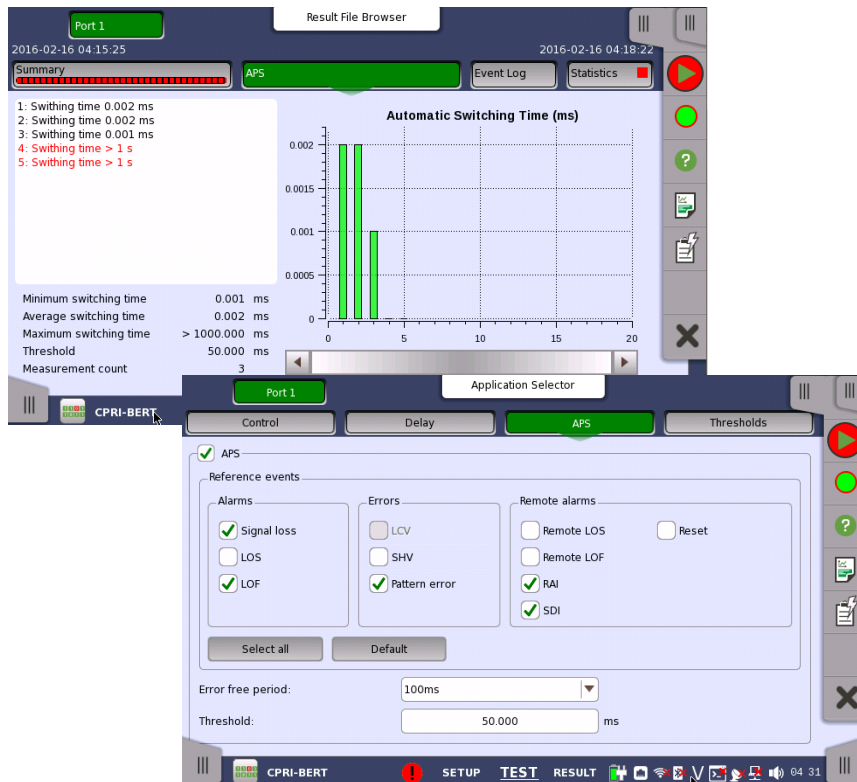

The screenshot displays the 'Event Log' window of the CPRI BERT application. It shows a table of test results with columns for No., Time, Port, Type, Src., Description, and Dur./Count. The table contains 12 rows of data, including APS switching time, Pattern error, Signal loss, and Test Stopped events.

No.	Time	Port	Type	Src.	Description	Dur./Count
4	2016-02-16 04:16:10	1	CPRI	CPRI	APS switching time	0.002 ms
5	2016-02-16 04:16:10	1	CPRI	CPRI	Pattern error	256
6	2016-02-16 04:16:25	1	CPRI	CPRI	APS switching time	0.001 ms
7	2016-02-16 04:16:25	1	CPRI	CPRI	Pattern error	50
8	2016-02-16 04:17:35	1	CPRI	CPRI	Signal loss	00:00:06
9	2016-02-16 04:17:36	1	CPRI	CPRI	APS switching time, Overflow	1000.000 ms
10	2016-02-16 04:17:54	1	CPRI	CPRI	Signal loss	00:00:02
11	2016-02-16 04:17:55	1	CPRI	CPRI	APS switching time, Overflow	1000.000 ms
12	2016-02-16 04:18:22				Test Stopped	

Graph and Event log screens for easy viewing and analysis

# CPRI over OTN

- Market requirements
  - CPRI over OTN:
    - Transport raw radio (CPRI) data from RE over optical fiber to central location for baseband processing
      - Single location serving multiple REs
      - Consolidation has huge power and cost savings over distributed approach without impacting network scalability
  - OTN supports transport of several protocols over same fiber
    - Same management system across network

# MT1000A CPRI Wire Line Testing

- Support for CPRI over OTN enables tests of latest CPRI implementations

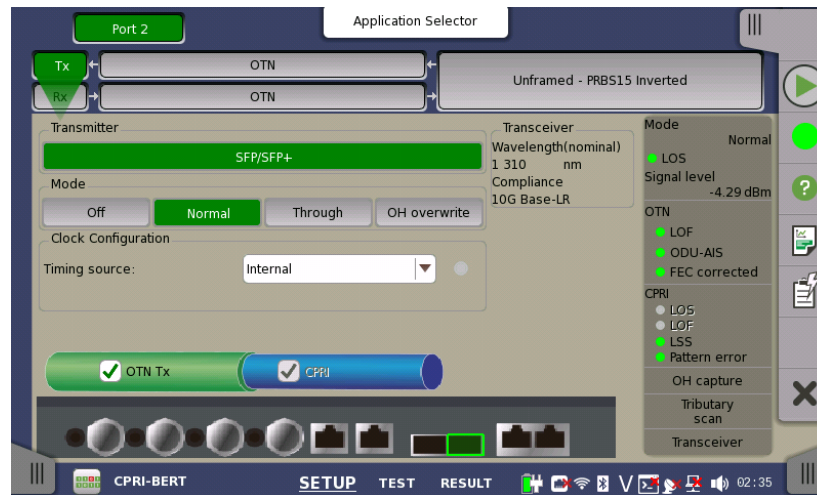

# MT1000A OBSAI Testing

OBSAI Frame Commissioning Test, Error/Alarm analysis, and APS and Delay measurements

- Helps cut costs of MFH I&M
- Ideal low-cost signal source and measuring instrument for developing and evaluating MFH transmission equipment

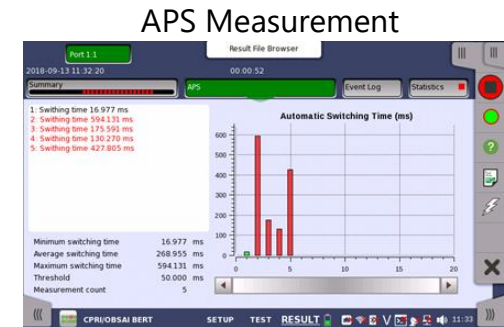
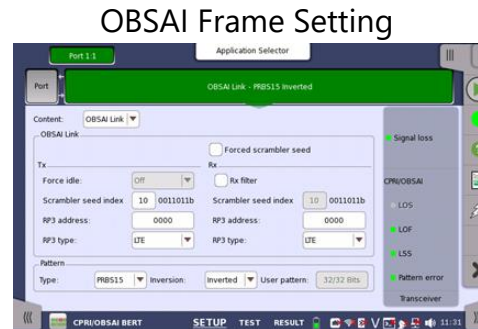
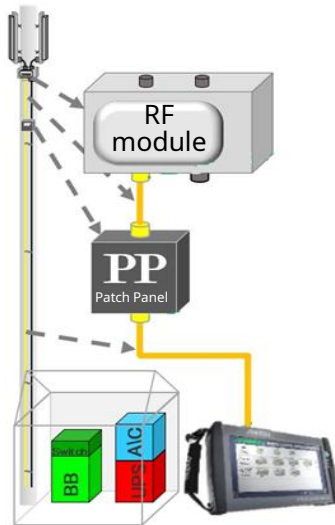

- Supported rates: 768 M, 1536 M, 3072 M, and 6144 Mbps
- Tx/Rx status data display
- RP3 Address, and Type editing
- 6144 M auto-scrambling, Scramble SEED manual setting

## Useful Point !

Supports confirmation of Tx/Rx settings at one screen and simplifies evaluation of connection conditions with status information. Moreover, simultaneous installation of OBSAI function, SEEK function, OTDR module and CPRI module combines all functions required by MFH on-site tests in one unit for excellent maintainability and reduced costs.

# eCPRI/IEEE1914.3

- Market

- Most MFH networks are based on CPRI and will have to move to these new frame formats for 5G or before allowing the operator to manage the massive increase in data throughput requirements.
- IEEE 1914.3 frames will likely also to be utilized back into the MBH as the architecture as the connection from Core / Metro to the MFH will evolve.

MT1000A support BER test of eCPRI/IEEE 1914.3

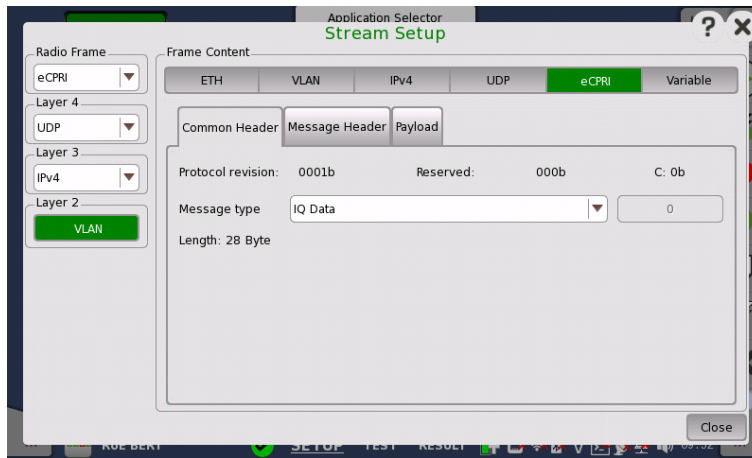

eCPRI Frame Setting

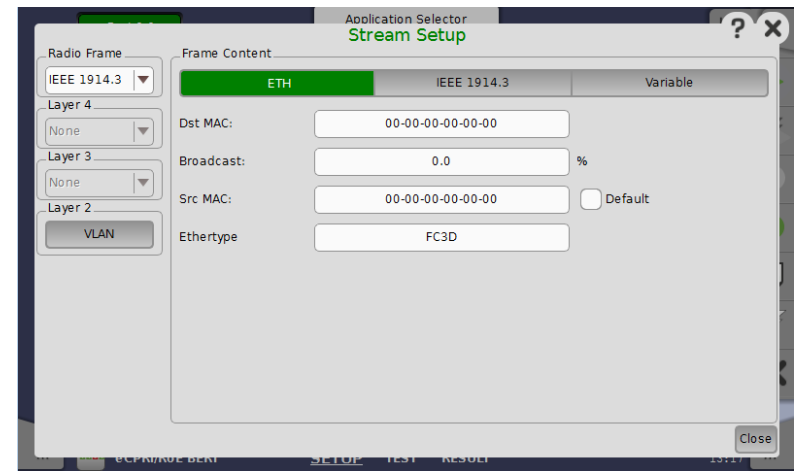

IEEE1914.3 Frame Setting

# eCPRI/IEEE1914.3(RoE) 25G Dual port solution

- Market

- Conventional fronthaul and backhaul network configurations are being re-examined to support 5G services and a switchover to eCPRI and RoE (Radio over Ethernet) packet-based protocols is being examined as part of this change.

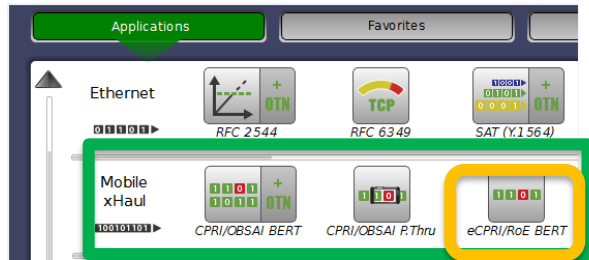

Mobile xHaul application

With dual-port 25G eCPRI/RoE measurement support, the MU100011A offers efficient signal generation and analysis plus precision one-way latency measurement of Transport networks, supporting tests for implementing ultra-Reliable Low-Latency Communications (uRLLC).

This will play a key role in Next Generation Fronthaul Interface (NGFI) network configurations and Fronthaul Transport Node (FTN) evaluations.

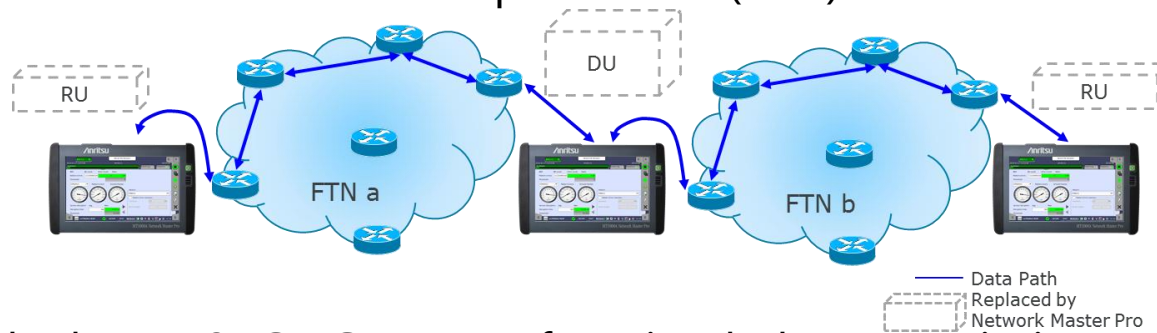

— Data Path  
 Replaced by Network Master Pro

- Using the dual-port 25G eCPRI/RoE function helps to optimize testing while cutting the number and cost of required test instruments.

# Network Master Pro MT1000A

- Powerful Storage Area Networking (SAN) Tests
  - Fibre Channel Functions

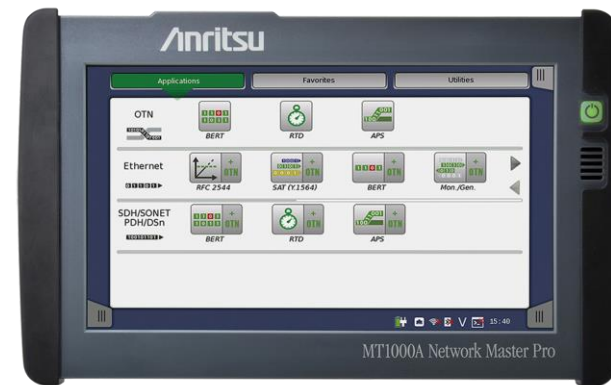



# MT1000A Product Highlights

- Powerful tests of Fibre Channel links
  - Test of 1 GFC, 2 GFC, 4 GFC, 8 GFC, 10 GFC and 16GFC
    - Optional mapping to OTN
  - Performance Test
  - Latency measurement
  - BER testing including service disruption measurement
  - Line alarm and error monitoring
  - Normal or Reflector mode

# MT1000A Product Highlights

- Color-coded displays give easy overview of GO/NO-GO results on Fibre Channel links
- Powerful Fibre Channel statistics include Latency, Packet Jitter and service disruption information
  - Optional threshold settings for easy understanding of results

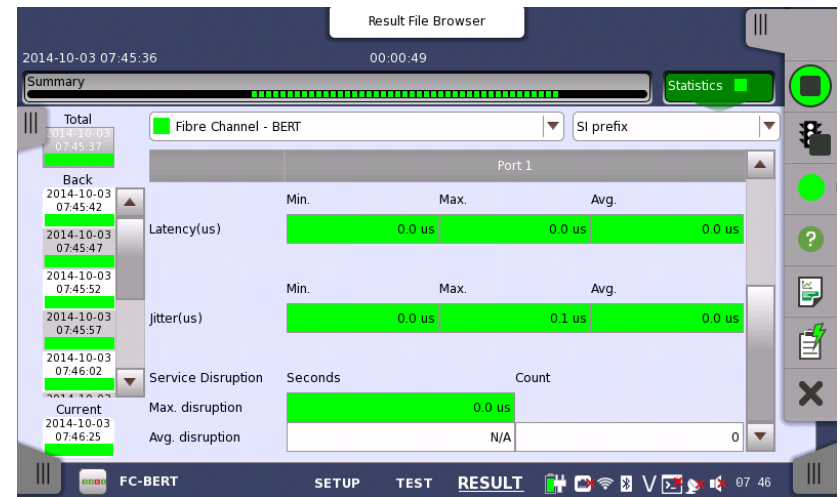
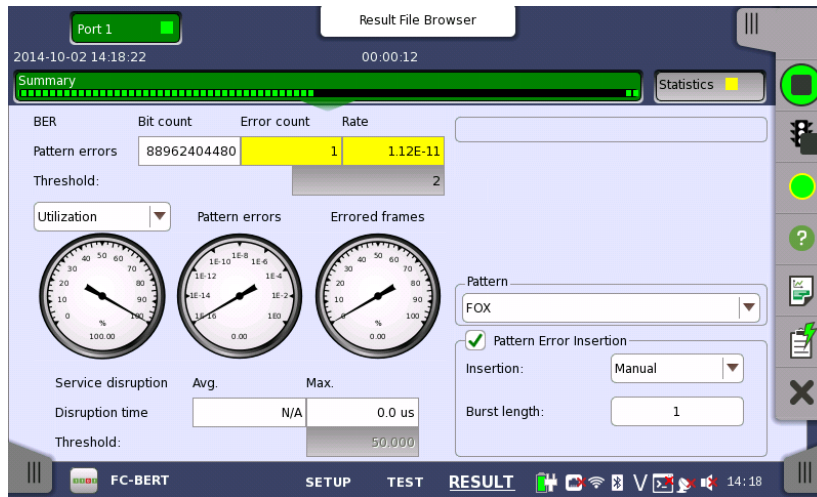

# MT1000A Product Highlights

- Point-to-point and Fabric topology
- Latency, Packet Jitter and service disruption measurements

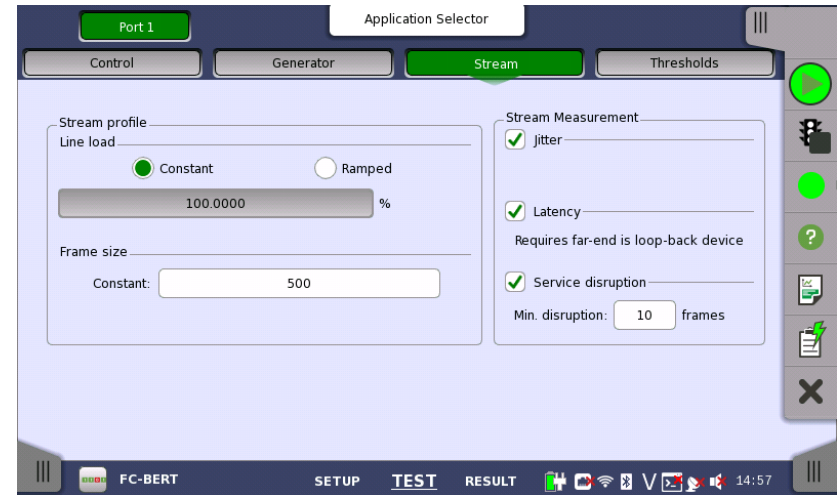
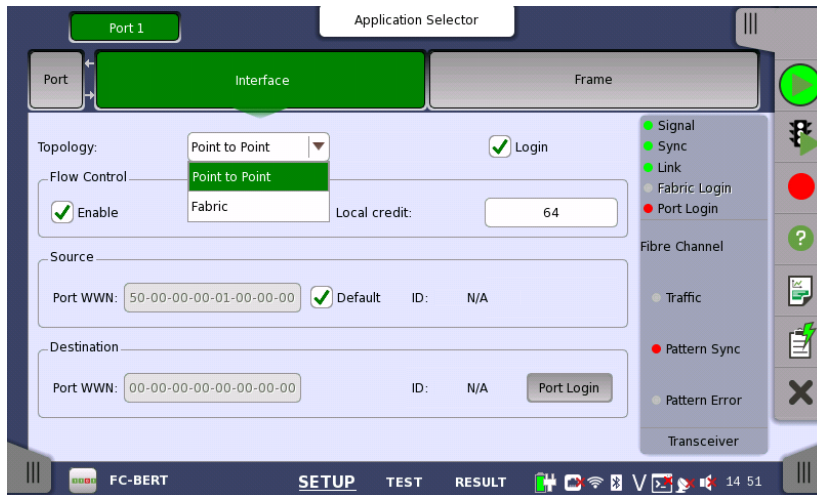

# MT1000A Product Highlights

- Performance test application to Fibre channel interface
  - Supports throughput, latency, and buffer credit performance verification for Fibre channel networks and Fibre channel equipment

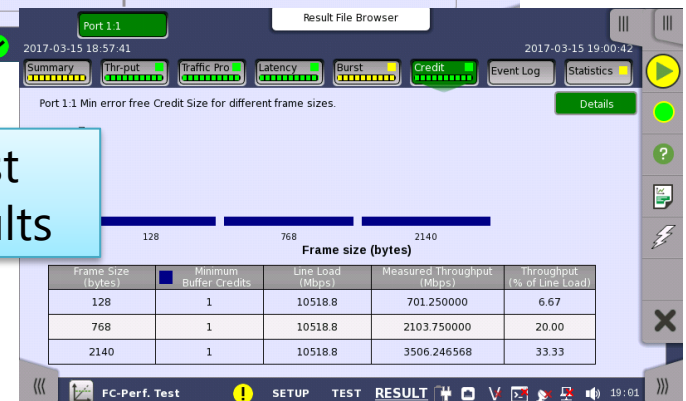
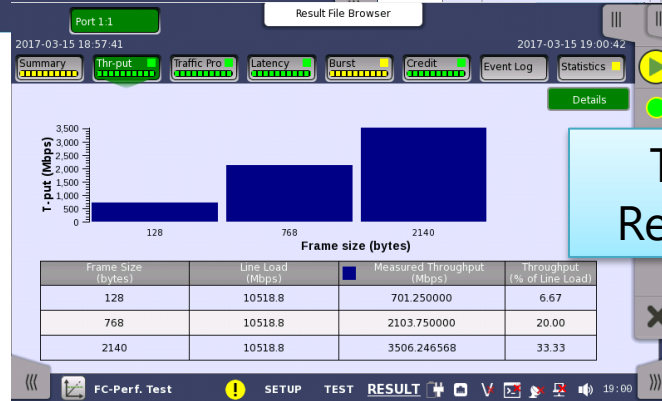
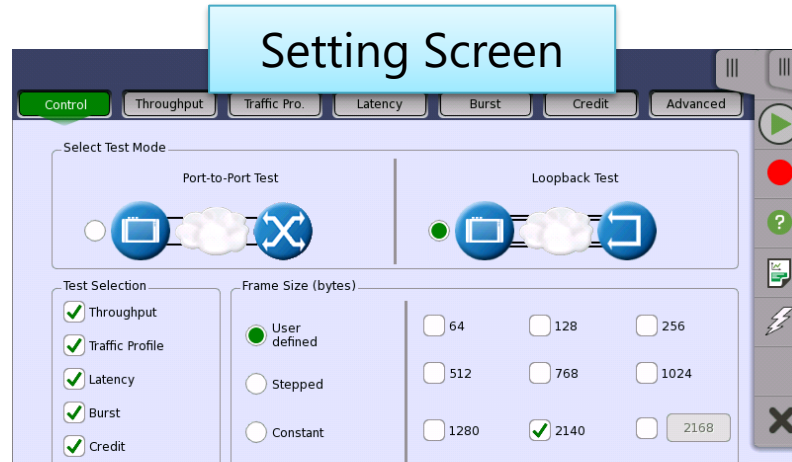
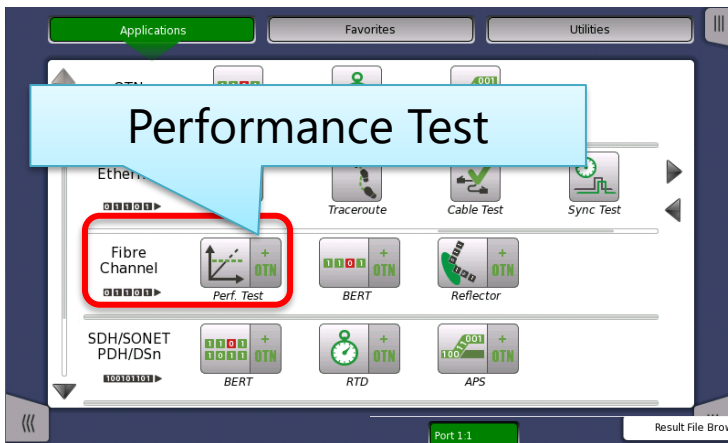

# Network Master Pro MT1000A

- OTN Metro and Core Network Installation and Maintenance

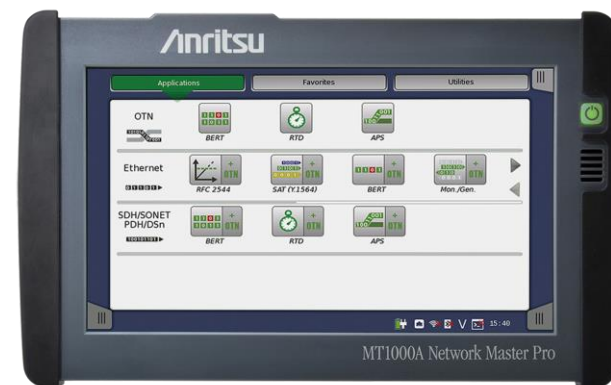

# OTN Background

- ITU-T defines an Optical Transport Network (OTN) as a set of Optical Network Elements (ONE) connected by optical fiber links, able to provide functions of transport, multiplexing, switching, management, supervision and survivability of optical channels carrying client signals.
  - Typical signals carried by OTN are:
    - SONET/SDH
    - Ethernet
    - Fibre Channel
    - CPRI
  - Key OTN functions include:
    - Mapping/demapping of non-OTN signals
    - Multiplexing and demultiplexing of OTN signals
    - Forward Error Correction

# OTN Background

- OTN networks first designed for submarine sections
  - Quickly moved to Core → Metro → Access
    - Operators can implement more services, control and management
- Simplifying network management is key for operators
  - Control customer traffic from access point and across network (single system, single management)
  - Greater insight about faults, quick repair and fewer maintenance issues
  - Single management of all legacy and replacement technologies

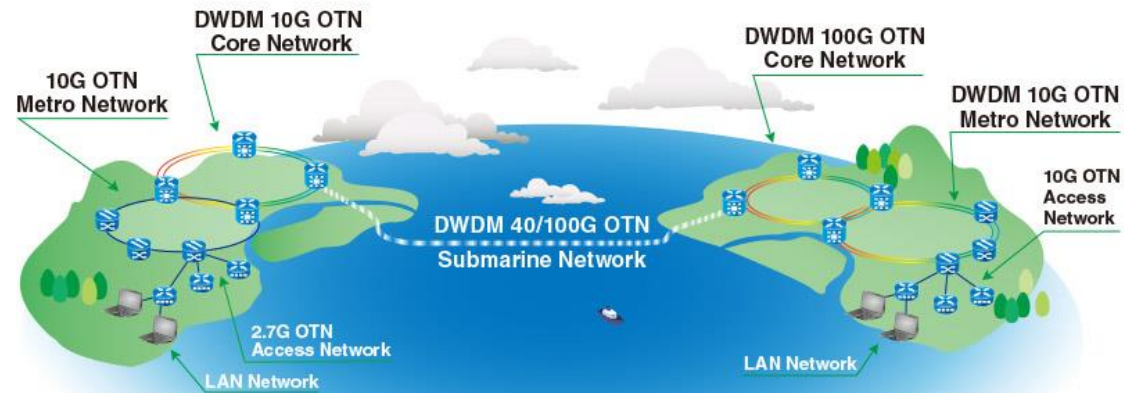

# MT1000A OTN Test Function

- Comprehensive OTN testing for metro and core network I&M
  - OTU1, OTU2, OTU3, OTU4, OTU1e, OTU2e, OTU1f, OTU2f, OTU3e1, OTU3e2 tests
  - ODU0, ODUflex\*1, ODU1, ODU2, ODU3, ODU4.  
ODU0 to ODU4 multistage mapping
  - Test Ethernet, CPRI, Fibre Channel and SDH/SONET client signals mapped to OTN signal
  - OTN tests with bulk signals at OTN level
  - Comprehensive OTN error and alarm statistics
  - OTN error performance measurement (G.8201 or M.2401)
  - ITU-T O.182-compliant FEC test
  - Delay measurement
  - OTN header edit and capture
  - OTN TCM monitoring and generation
  - Service disruption analysis using APS application
  - OTN tributary scan

\*1 Up to OTU2



# MT1000A OTN Test configuration (1/3)

- OTN out-of-service testing
  - For installation and commissioning
  - For troubleshooting
  - OTN testing with far-end loopback

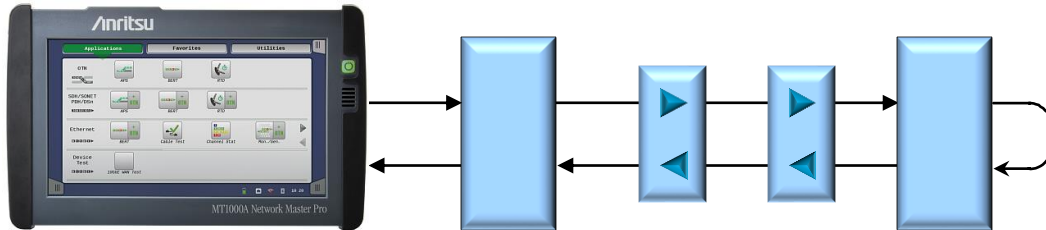

- OTN testing with two instruments
  - Separate results for each side of line

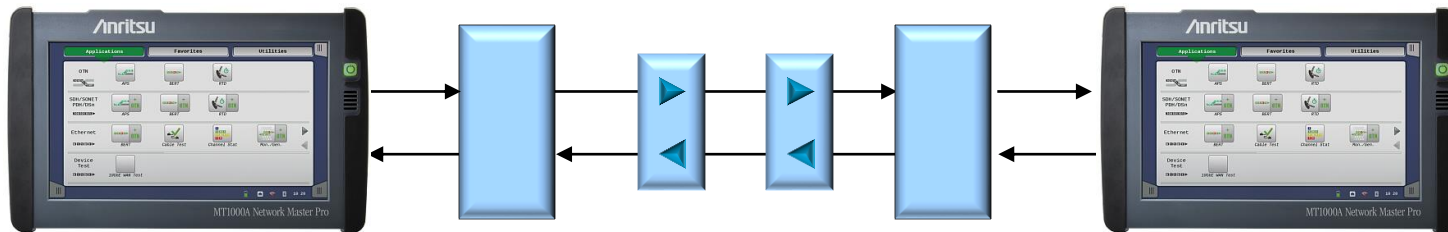

# MT1000A OTN Test configuration (2/3)

- OTN in-service testing
  - Troubleshooting live traffic
  - Connected at monitoring point

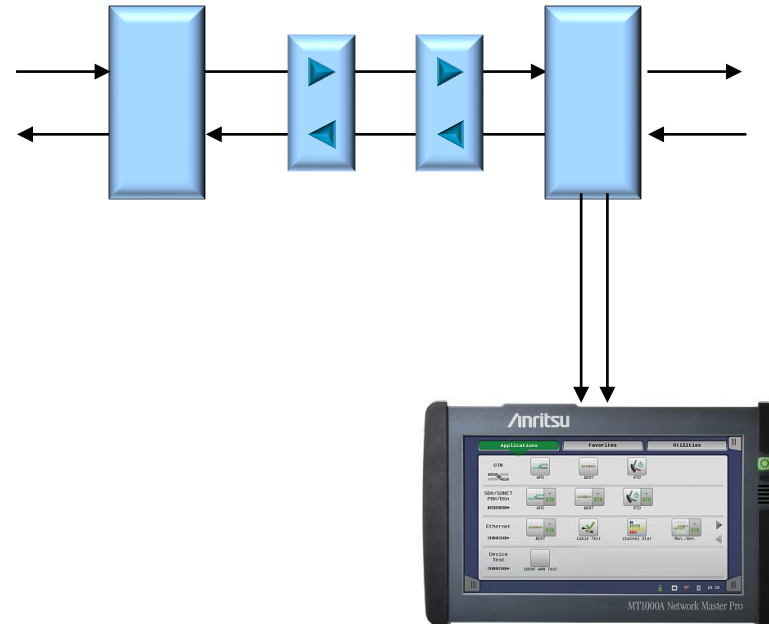

# MT1000A OTN Test configuration (3/3)

- OTN in-service pass-through testing
  - Troubleshooting live traffic when no monitoring point

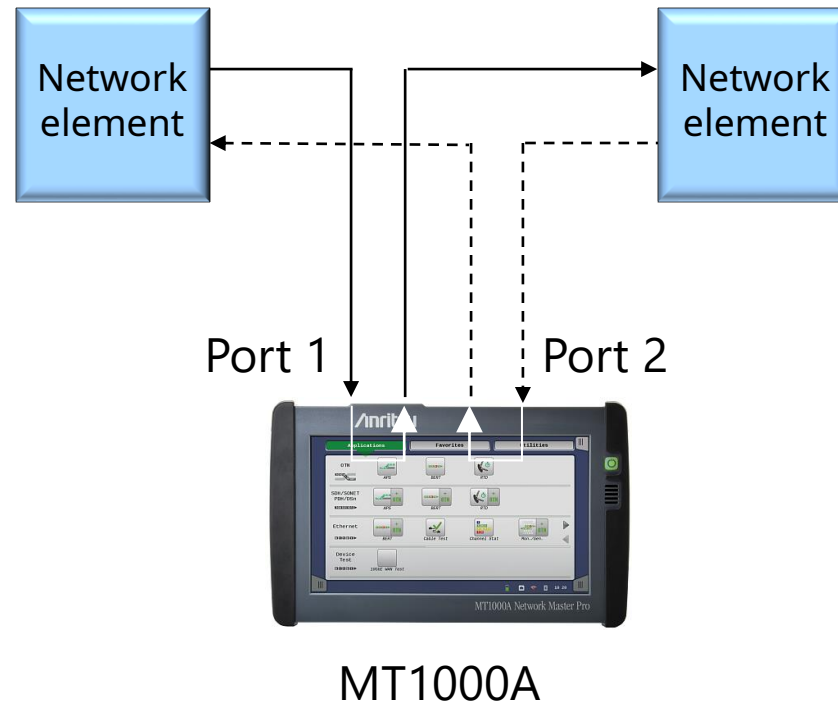



# MT1000A OTN Mapping OTU3

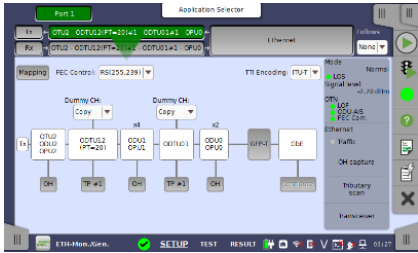
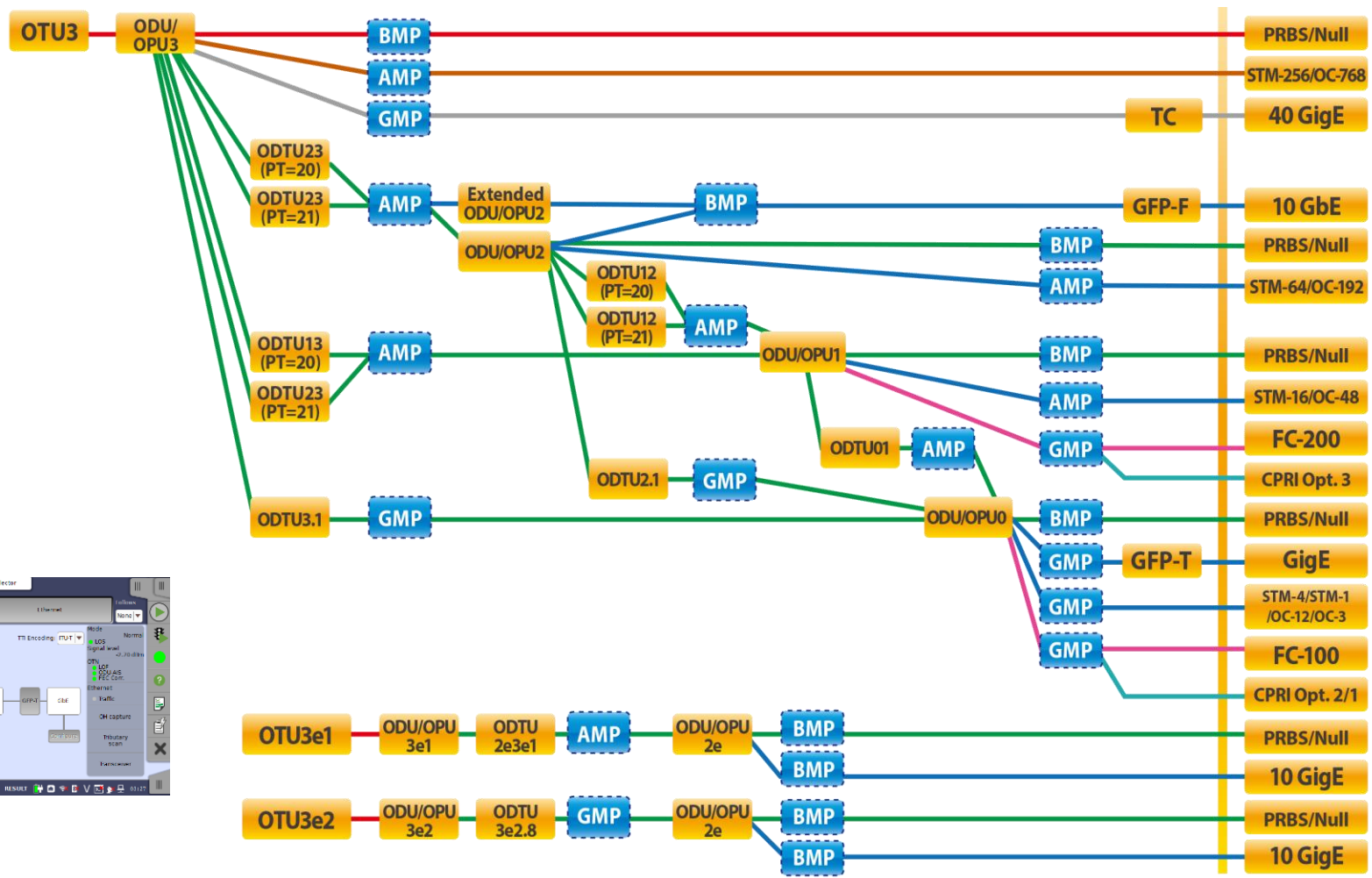

- MU100011A-053 OTN 40 Gig Single Channel
- MU100011A-063 40/100G ODU Multistage
- MU100011A-001/003 Up to 10G Single/Dual Channel

- MU100011A-004/005 Up to 10G FC Single/Dual channel
- MU100011A-071/072 CPRI/OBSAI Up to 10G Single/Dual Channel
- MU100011A-013 Ethernet 40G Single Channel
- MU100011A-083 STM-256 OC-768 Single Channel

# MT1000A OTN Mapping OTU4

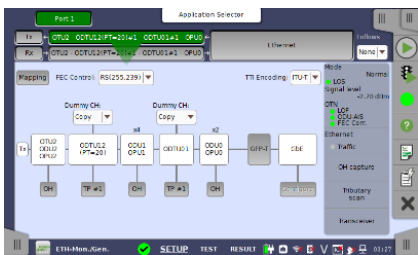
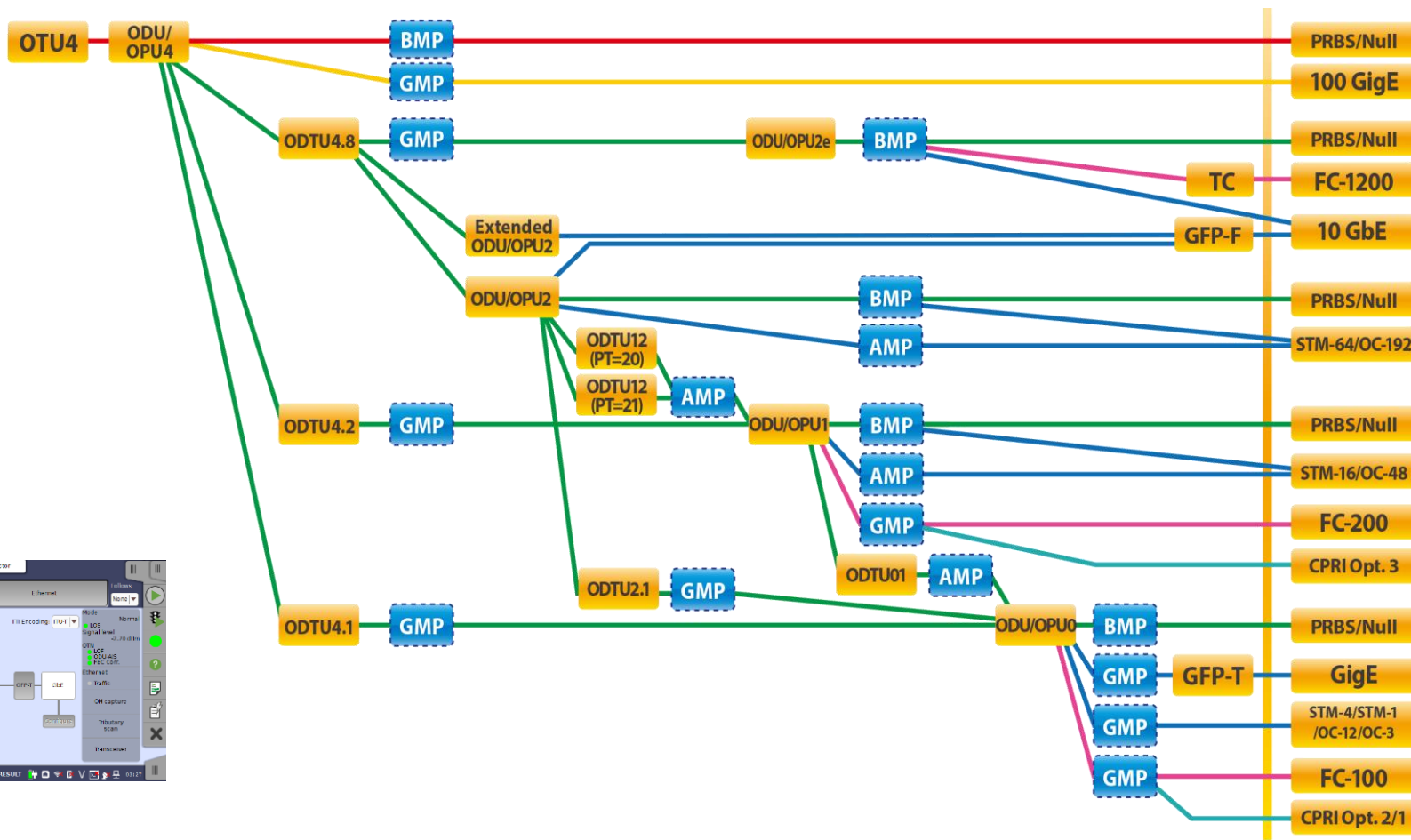

- MU100011A-055 OTN 100G Single Channel
- MU100011A-063 40/100G ODU Multistage
- MU100011A-001/003 Up to 10G Single/Dual Channel

- MU100011A-004/005 Up to 10G FC Single/Dual Channel
- MU100011A-071/072 CPRI/OBSAI Up to 10G Single/Dual Channel
- MU100011A-015 Ethernet 100G Single Channel

# MT1000A Product Highlights

- OTN statistics
  - Summary page with main results
  - Additional pages with detailed statistics
  - GO/NO GO color coding gives easy overview of results

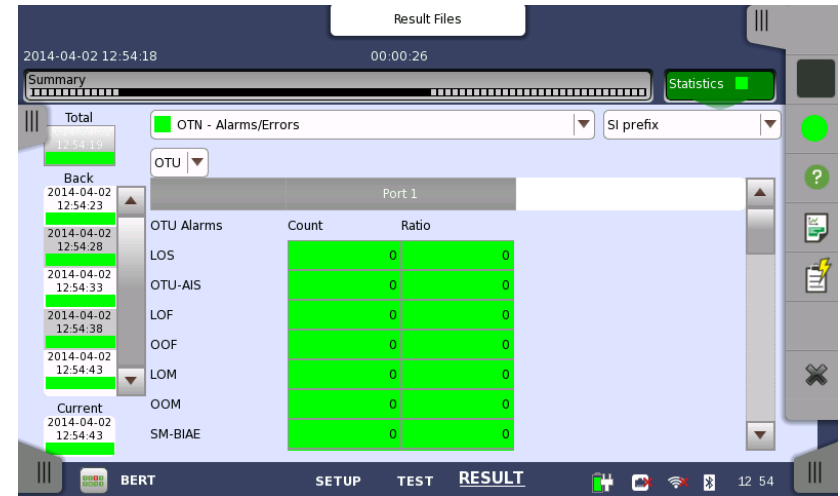
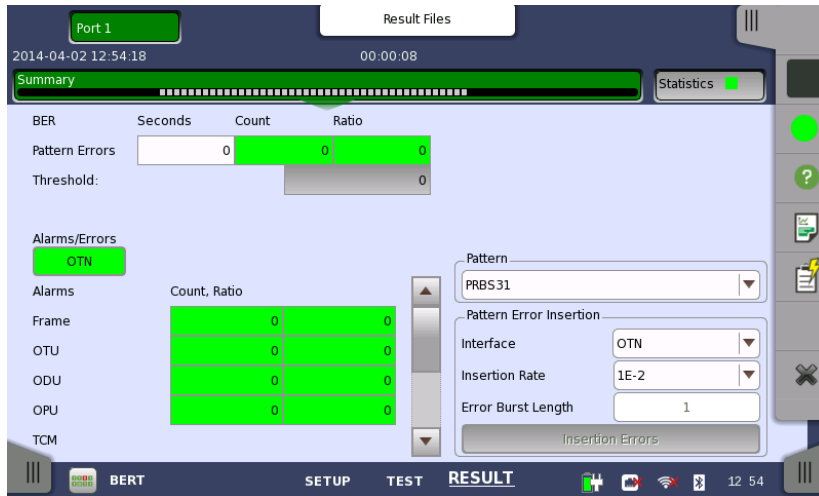

# MT1000A Product Highlights

- Ethernet in OTN
  - Statistics for OTN and embedded Ethernet signal in same measurement
  - Client signal frequency
  - Intuitive configuration map

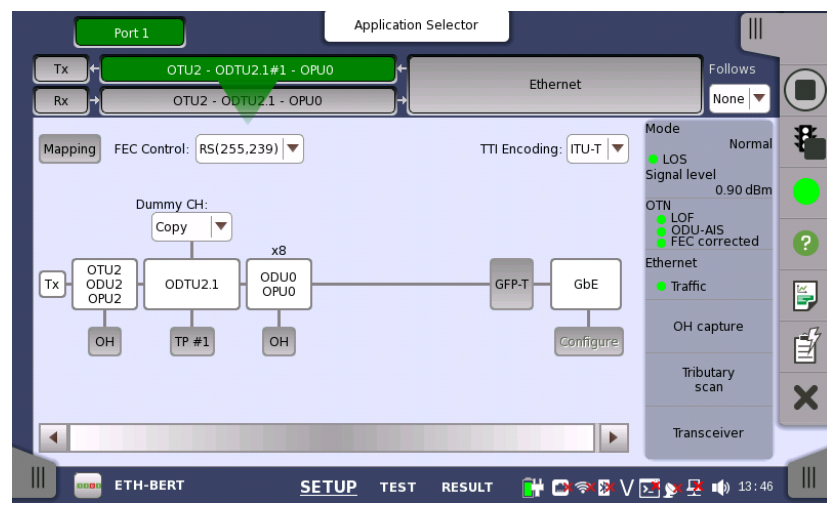
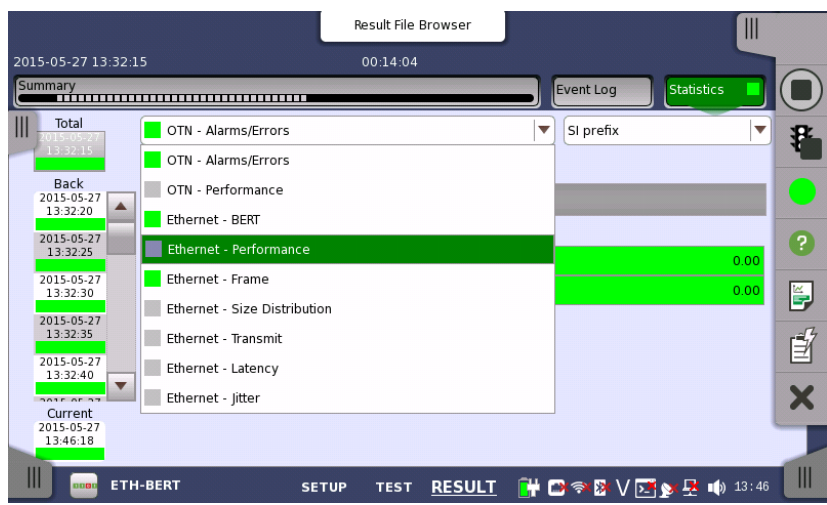
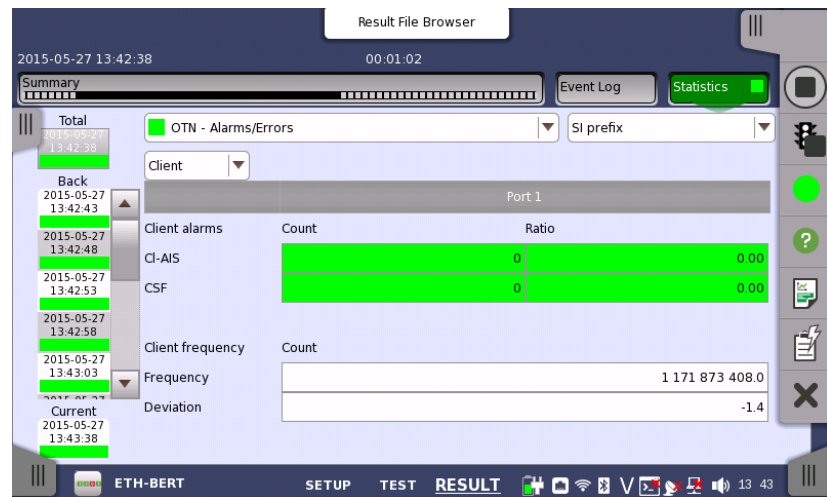



# MT1000A Product Highlights

- SDH/SONET/DSn/PDH in OTN
  - BERT applications and upgraded to switch without closing BERT, APS and RTD applications to improve operation efficiency

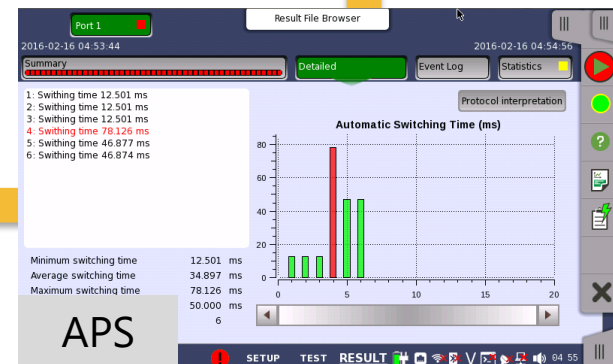
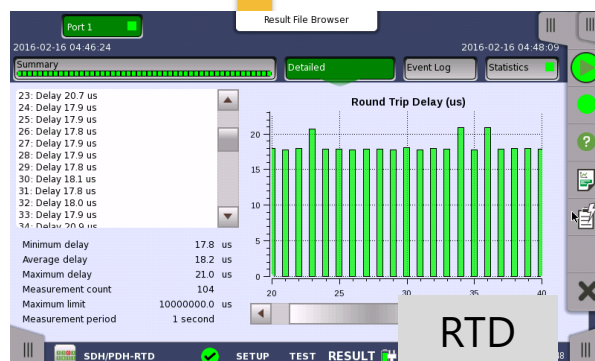
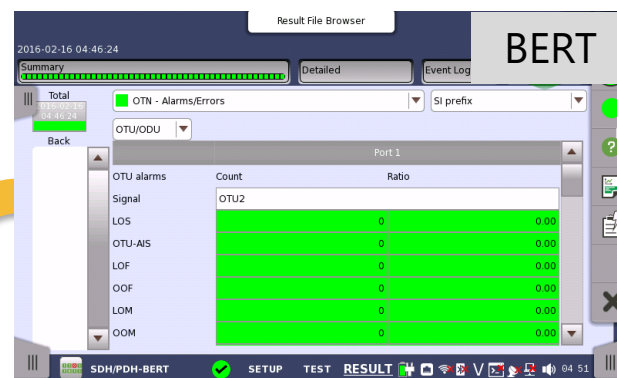
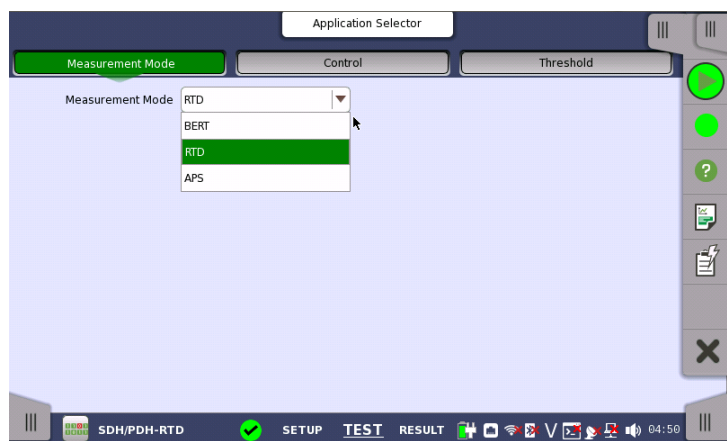

# MT1000A Product Highlights

- SDH/SONET in OTN
  - Upgraded Client signal selection method used for ATN mappings at SDH-OTN-BERT application, and enabled Client SDH and Client PRBS signal switching without closing applications to improve operation efficiency

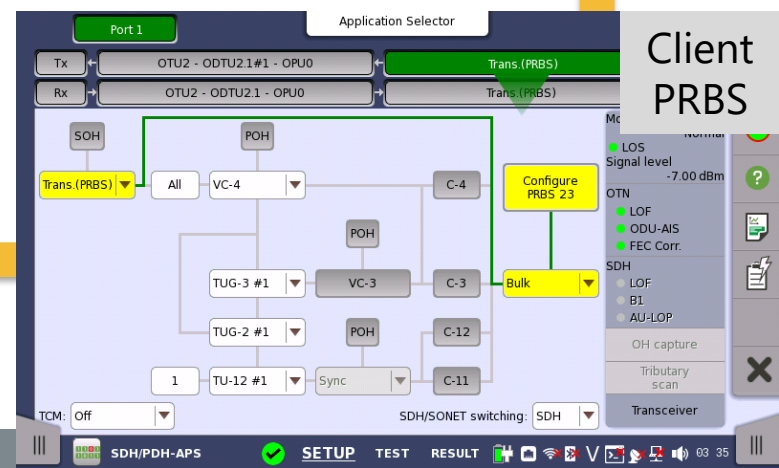
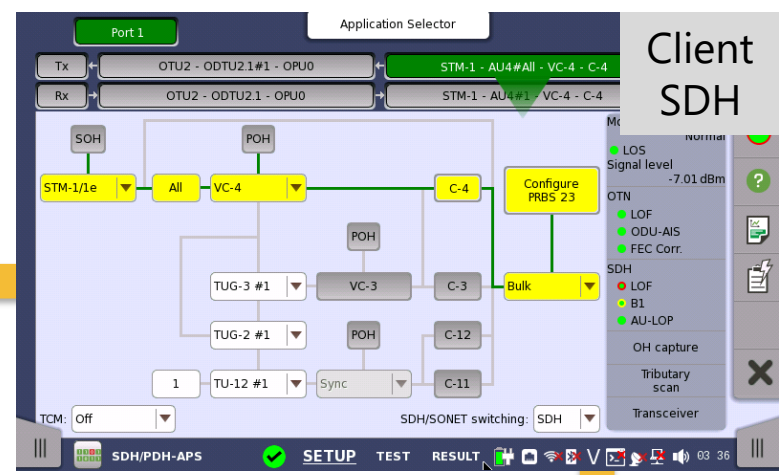
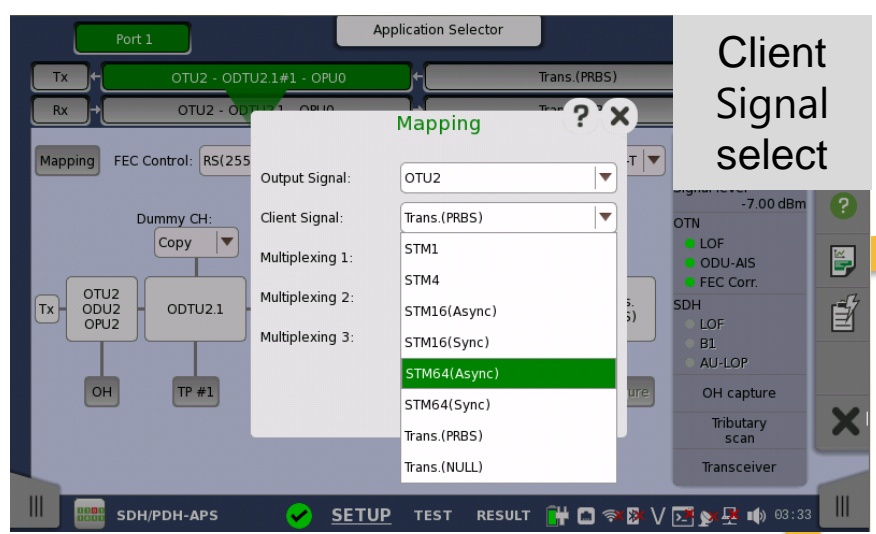

# MT1000A Product Highlights

- OTN status information
  - Overview of current status of alarms and errors
  - Optical level and rate information
  - GO/NO GO color coding gives easy overview of line status

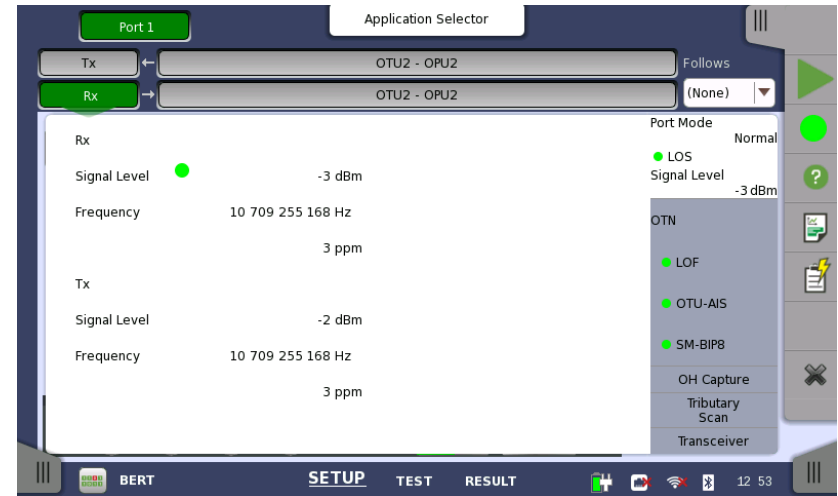
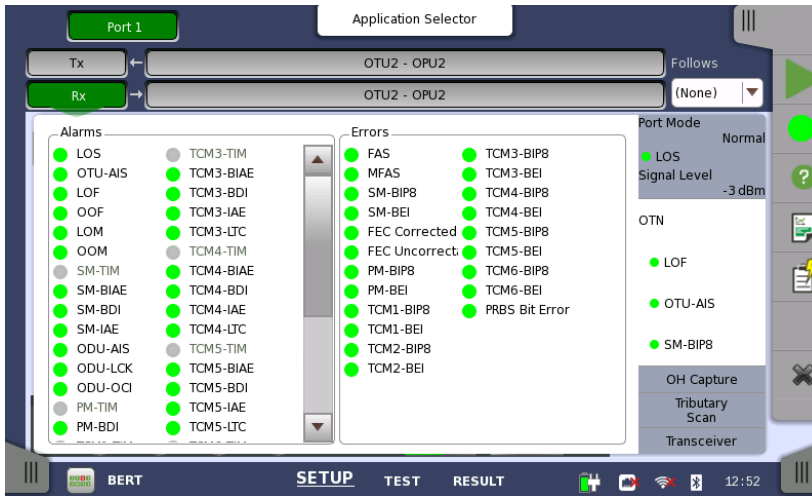

# MT1000A Product Highlights

- OTN Over Head (OH) Byte capture
  - Inspect OH bytes for detailed troubleshooting
    - Updates about every 1 second

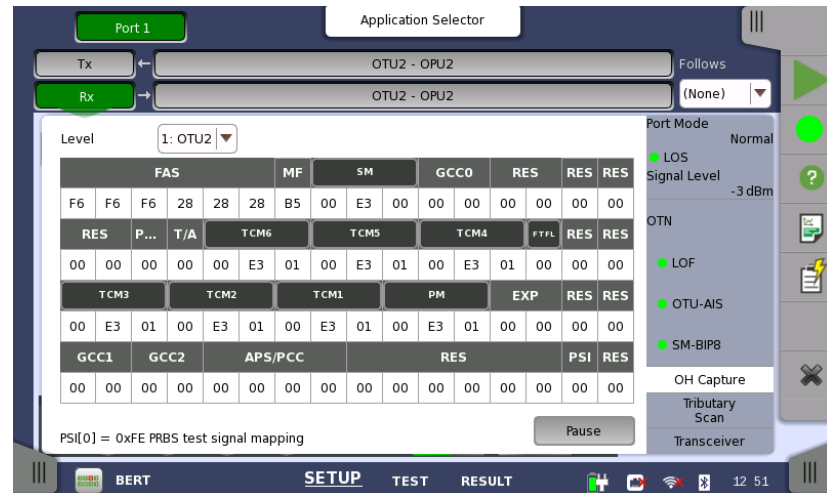

# MT1000A Product Highlights

- Comprehensive OTN Testing—continued
  - ODUflex testing
    - ODUflex: New feature of OTN
    - Method for flexible allocation of bandwidth to client signal
      - Makes most efficient use of OTN capacity
    - Capacity of ODU2 split into eight 1.25G ODUflex time slots

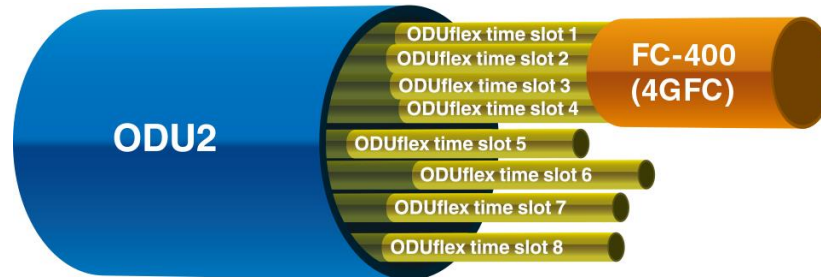

- In above example, FC-400 (4GFC) Fibre Channel signal occupies four ODUflex time slots, freeing other four ODUflex time slots in ODU2 for other payloads
- MT1000A supports ODUflex testing, allowing operators deploying new technology to verify working correctly throughout network

# MT1000A Product Highlights

- ODUflex
  - Configuration and results

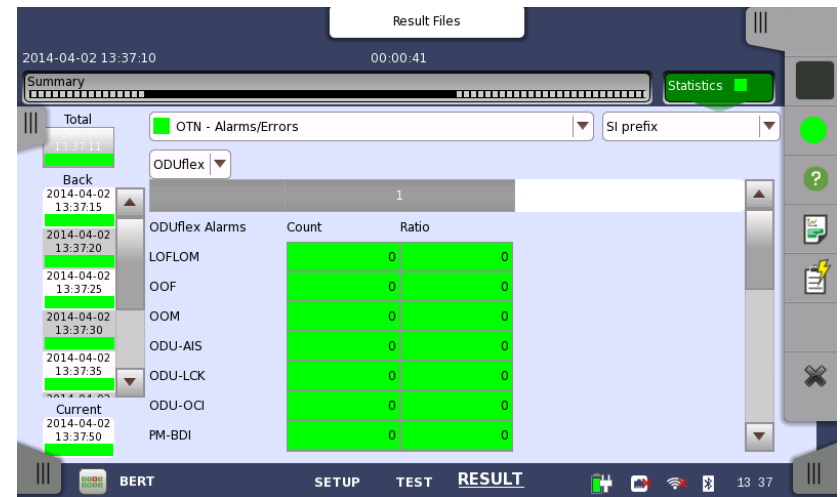
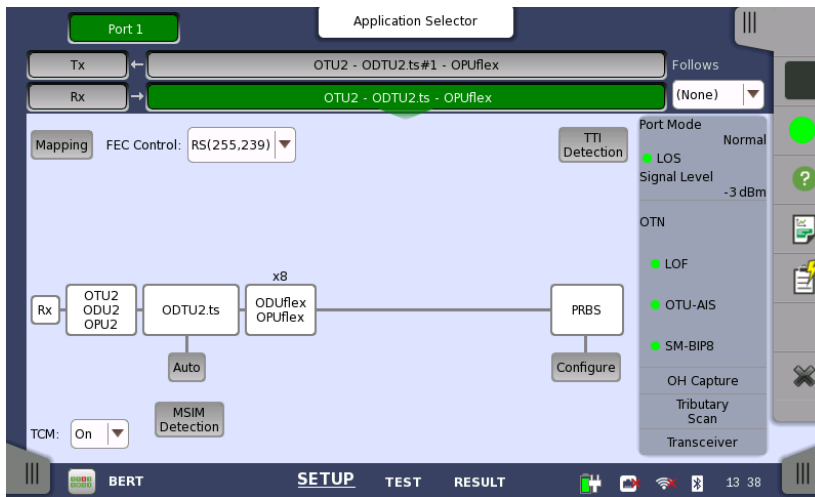

# MT1000A OTN FEC Test

- ITU-T O.182 Compliant FEC Test

- Anritsu's proposed FEC performance tests using Poisson distribution random errors adopted by ITU-T O.182 in July 2007
- Reproducible/accurate FEC error correction tests by generating random signal errors (Poisson distribution)

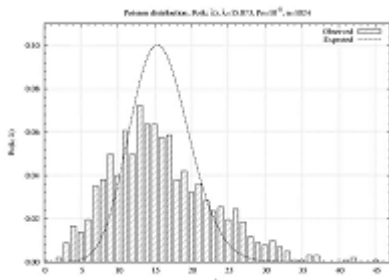

**Bad Random Distribution**

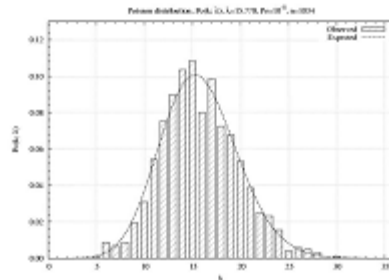

**Good Random Distribution**

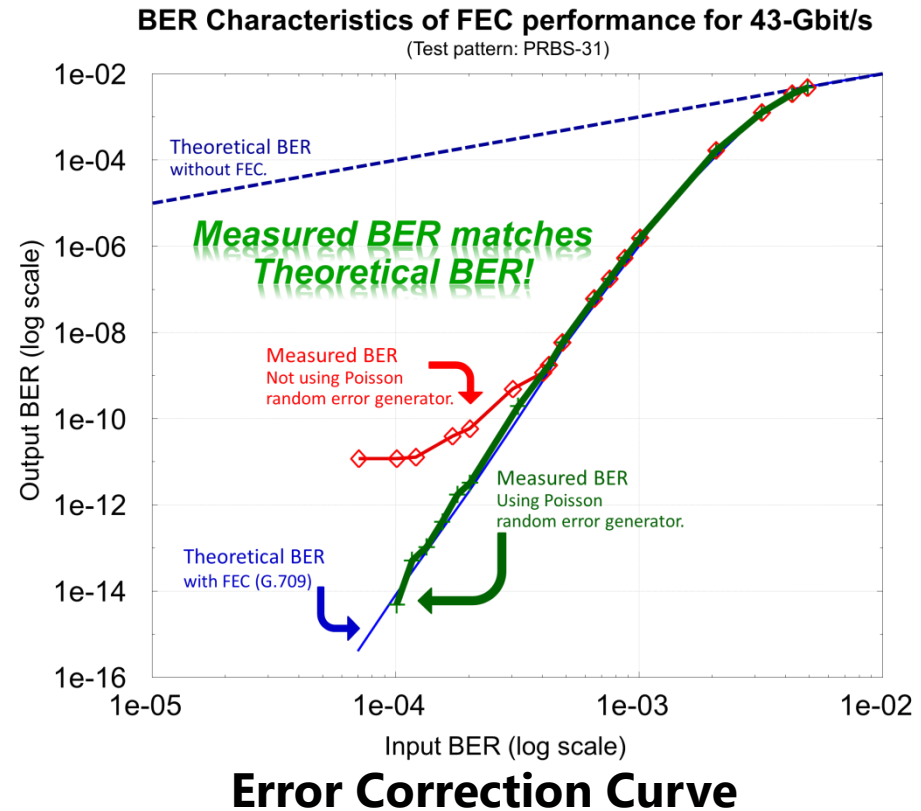

# MT1000A OTN FEC Test

- ITU-T O.182 Compliant FEC Test
  - FEC error insertion with MT1000A

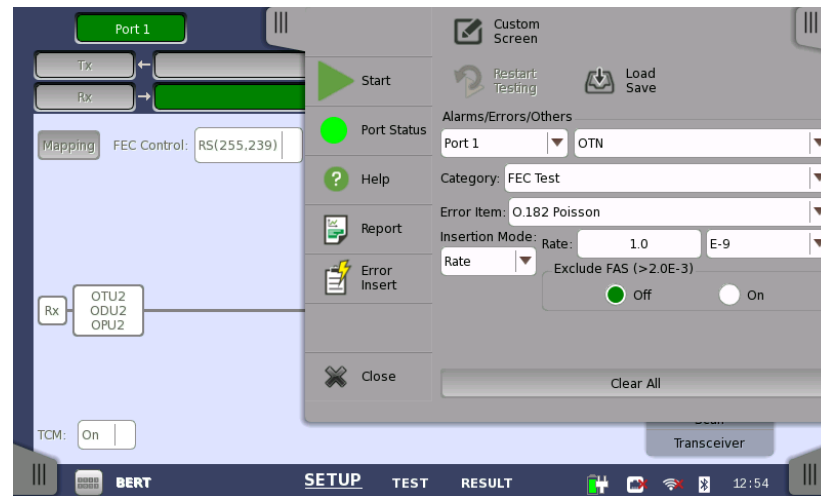



# Network Master Pro MT1000A

- Quick and Easy Tests of SDH/SONET/PDH/DSn Networks

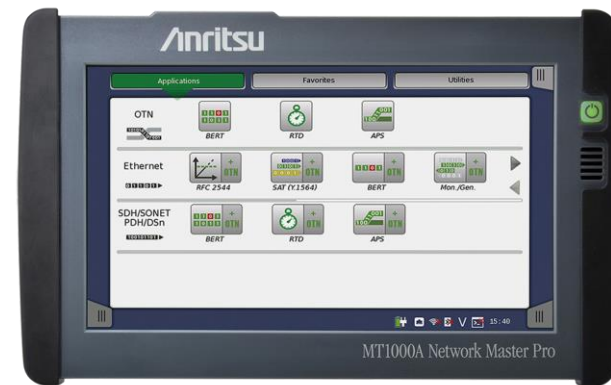

# MT1000A Product Highlights

- Quick and easy tests of SDH/SONET/PDH/DSn
  - Testing of SDH/SONET systems at STM-64/STM-16/STM-4/STM-1/OC-192/OC-48/OC-12/OC-3/STS-3 and embedded PDH (E1/E3/E4) and DSn (DS1/DS3) systems
  - Powerful PDH (E1/E3/E4) and DSn (DS1/DS3) testing
  - Simultaneous bi-directional monitoring of SDH/SONET/PDH/DSn lines
  - SDH/SONET mapping and de-mapping
  - Comprehensive error and alarm statistics
    - G.826/G.828/G.829/M.2100 error-performance measurements on SDH/SONET traffic
    - G.826/M.2100 error-performance measurements on PDH/DSn traffic
  - SDH/SONET OH byte testing and monitoring
  - SDH/SONET trouble scan
  - SDH/SONET pointer event generation and monitoring
  - SDH/SONET/PDH/DSn delay measurements

# MT1000A Product Highlights

- SDH mappings

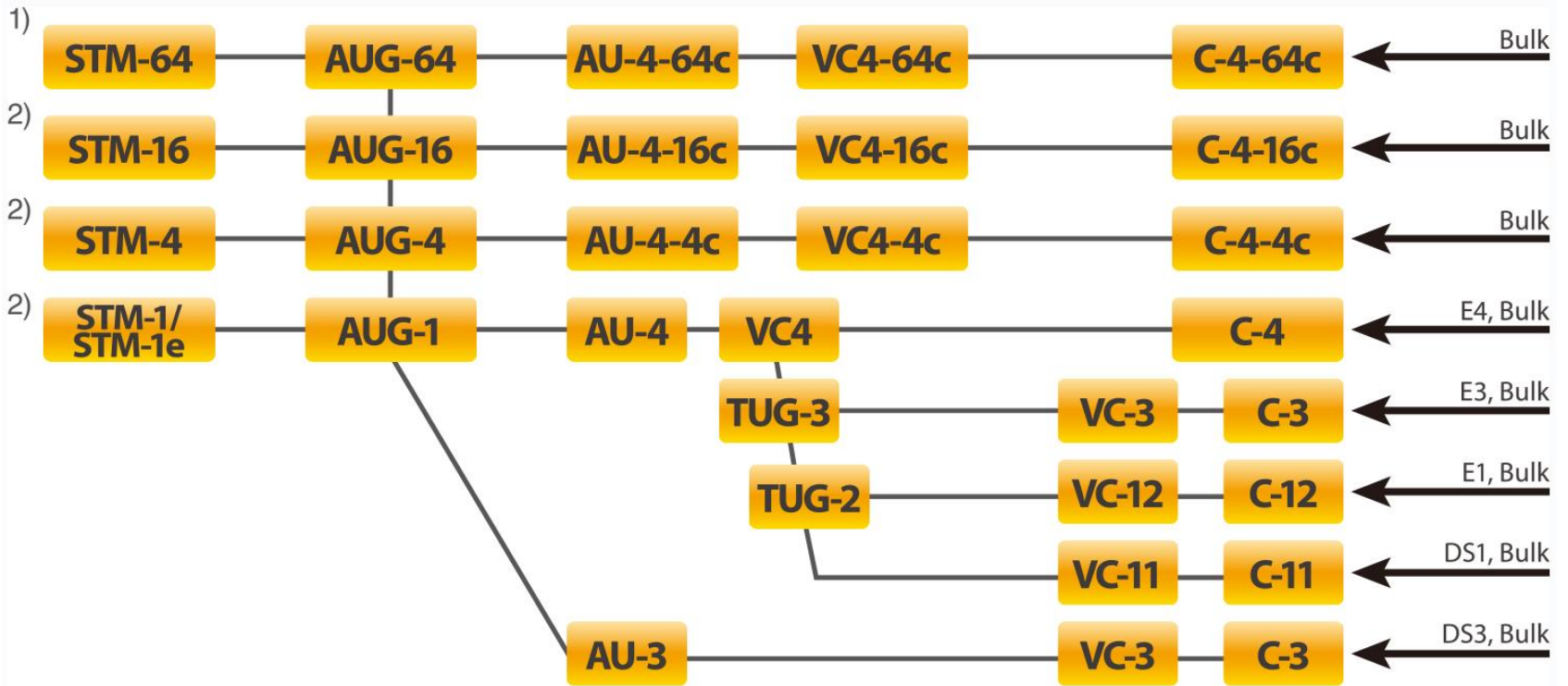

1) Requires MU100010A-081 or MU100010A-082

2) Requires MU100010A-001

# MT1000A Product Highlights

- SONET mappings

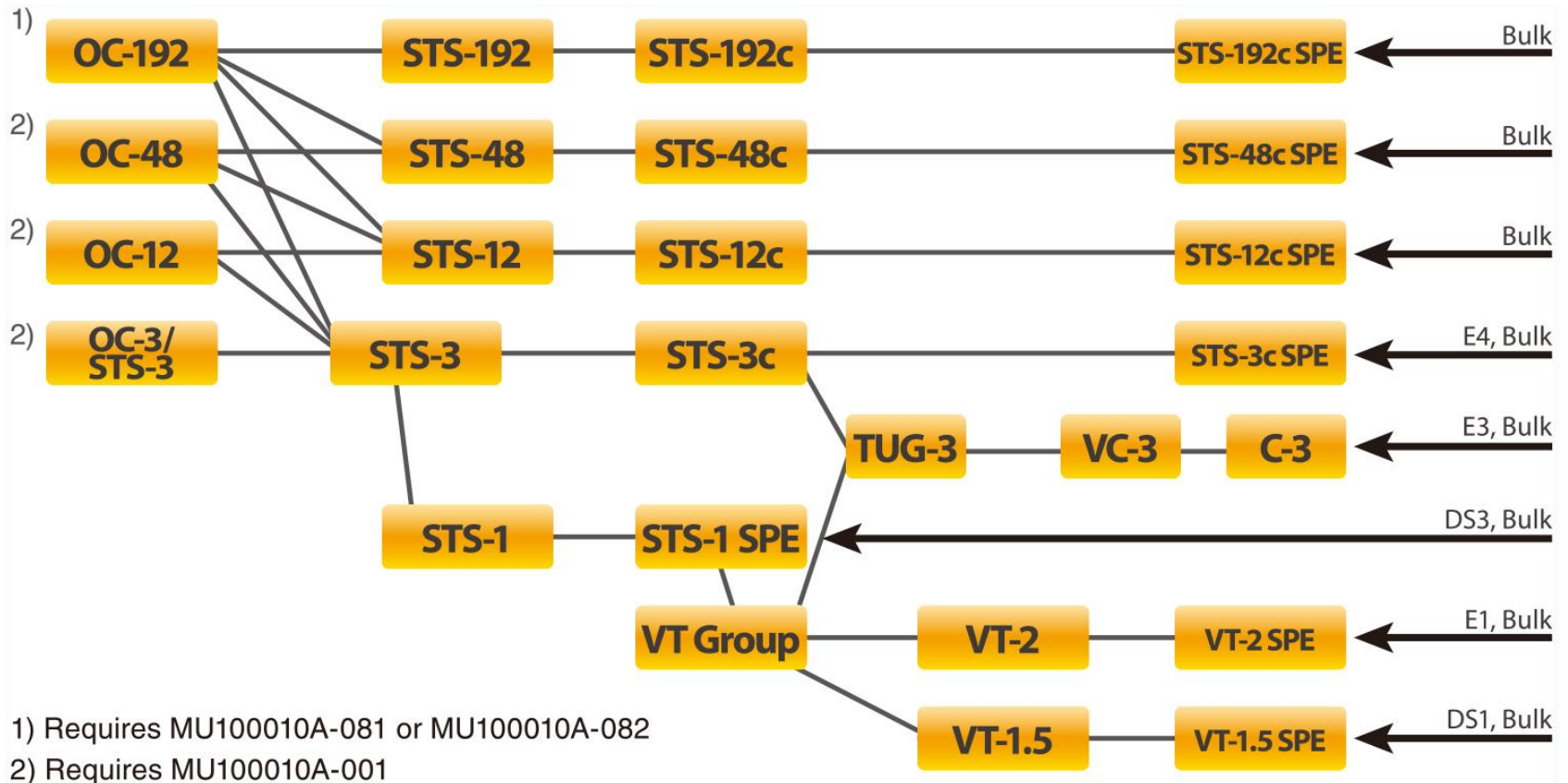

# MT1000A SDH/SONET In-Service Measurements

- Alarm and error monitoring for both sides of SDH/SONET line
- Frequency-deviation measurements
- G.826/G.828/G.829/M.2100 error-performance measurements on live traffic

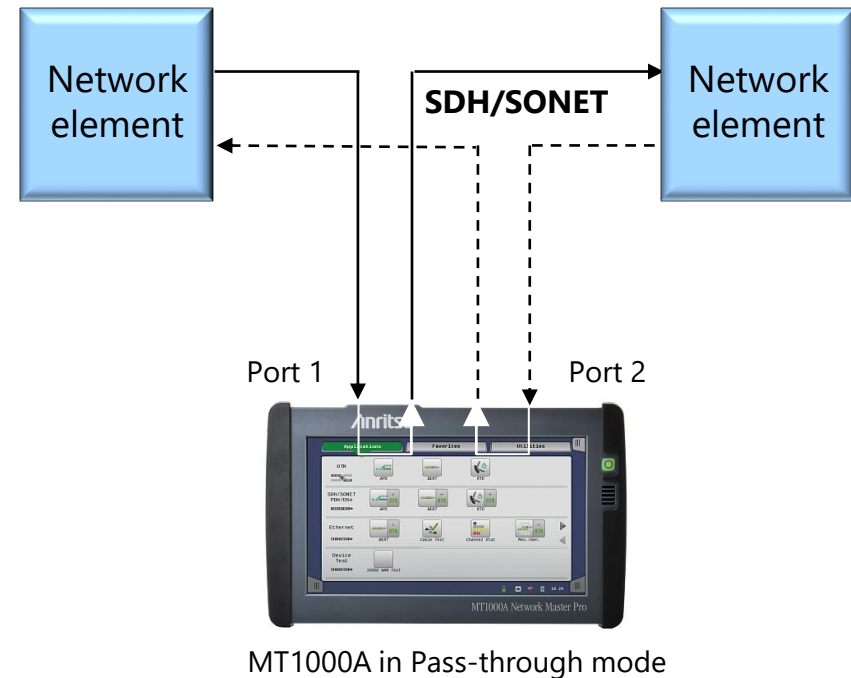
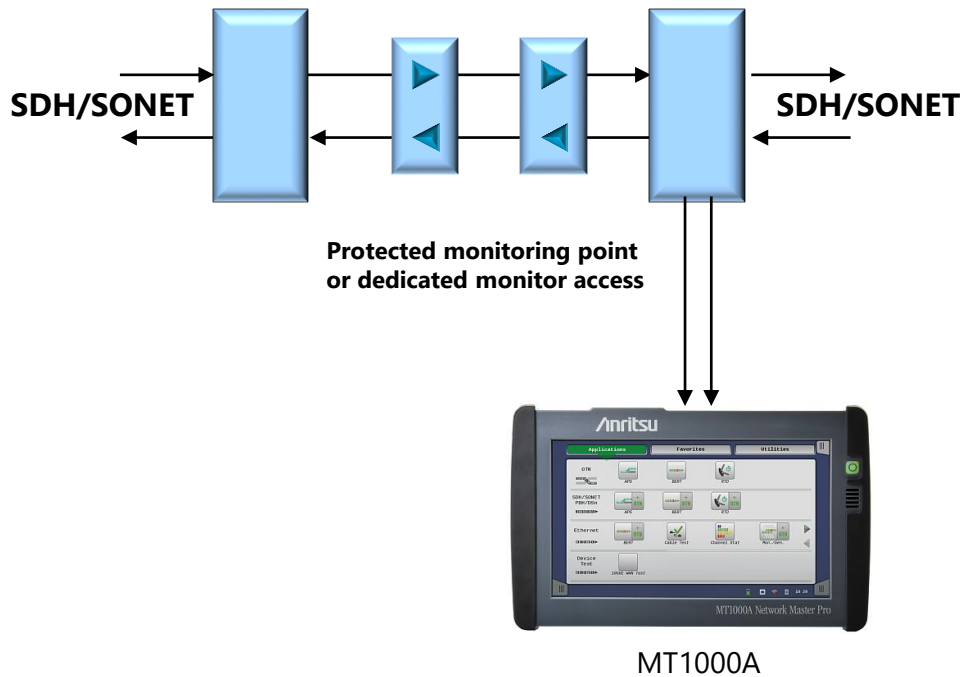

# MT1000A SDH/SONET Out-of-Service Testing

- Installing, commissioning and troubleshooting SDH/SONET lines
- Stressing system by generating alarms, errors, pointer operations, slip and frequency offset
- Testing synchronization circuits
- Generating embedded PDH/DSn signals
- G.826/G.828/G.829/M.2100 error performance
- Propagation time
- Alarm, error, slip and frequency-deviation measurements

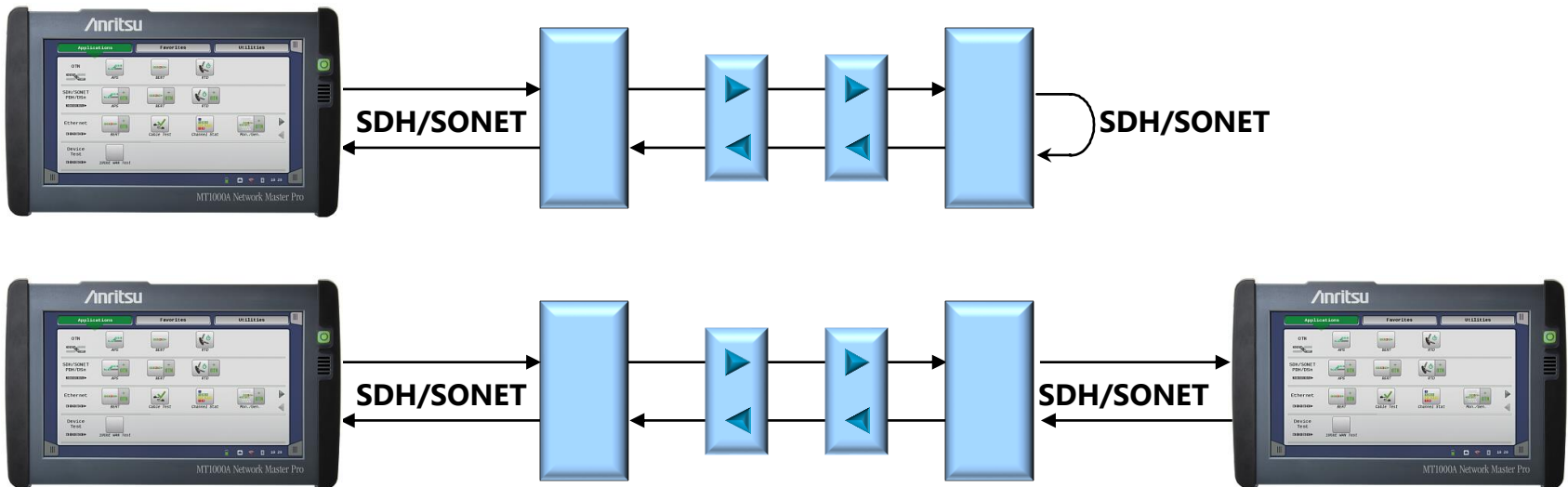

# MT1000A SDH /SONET Out-of-Service Testing

- Installing/commissioning
- G.826/G.828/G.829/M.2100 error-performance measurements
- System stressing by generating alarms, errors, slip and frequency offset
- Testing synchronization circuits
- Alarm, error, drift and frequency-deviation measurements
- Propagation time measurements

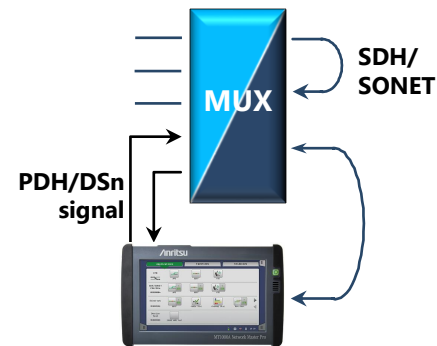
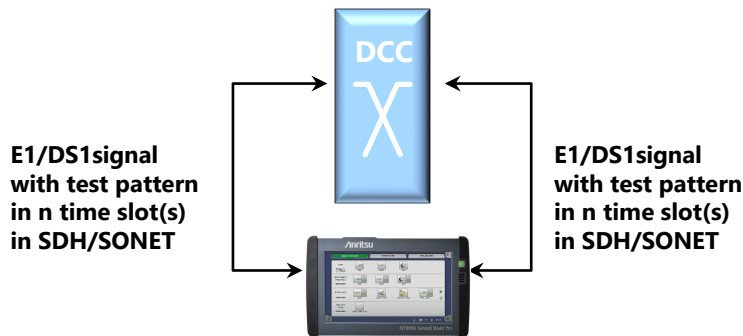

# MT1000A SDH/SONET Line Status

- Physical line information
- Current alarms and errors

The screenshot displays the 'Physical line information' section of the MT1000A interface. At the top, it shows 'Port 1' and 'Application Selector'. Below this, the Tx and Rx paths are defined: Tx is 'STM64 - AU4#All - VC-4 - C-12' and Rx is 'STM64 - AU4#1 - VC-4 - C-12', both connected to 'E1'. The 'Follows' dropdown is set to 'None'. The main display area shows SDH parameters: Rx Signal Level at -3 dBm, Deviation at 0 ppm, Bit Rate at 9 953 280 000 bps, and Tx Signal Level at -2 dBm. On the right, there are status indicators for 'Optical transmitter' (Normal), 'SDH' (LOS, LOF, B1, AU-LOP), and 'E1' (No Frame, AIS, Distant). A sidebar on the right contains 'OH Capture', 'Tributary Scan', and 'Transceiver' buttons.

The screenshot displays the 'Current alarms and errors' section of the MT1000A interface. It features the same top navigation as the first screenshot. The main display area is divided into three sections: 'Alarms', 'Errors', and 'Pointer information'. The 'Alarms' section lists LOS, LOF, OOF, MS-AIS, MS-RDI, AU-AIS, AU-LOP, HP-TIM, HP-PLM, HP-UNEQ, HP-RDI, TU-AIS, and TU-LOP. The 'Errors' section lists A1A2, B1, B2, B3, MS-REI, HP-REI, V5/B3, LP-REI, PRBS Errors, AU-NDF, TU-NDF, Switch, TC-IEC, TC-BIP-2, TC-REI, and TC-OEI. The 'Pointer information' section lists AU-Positive, AU-Negative, TU-Positive, and TU-Negative. On the right, there are status indicators for 'Optical transmitter' (Normal), 'SDH' (LOS, LOF, B1, AU-LOP), and 'E1' (No Frame, AIS, Distant). A sidebar on the right contains 'OH Capture', 'Tributary Scan', and 'Transceiver' buttons.



# MT1000A SDH/SONET Tributary scan

- Quick overview of problems in monitored SDH/SONET signals
- Detailed problem description when required
  - Click tributary for more details

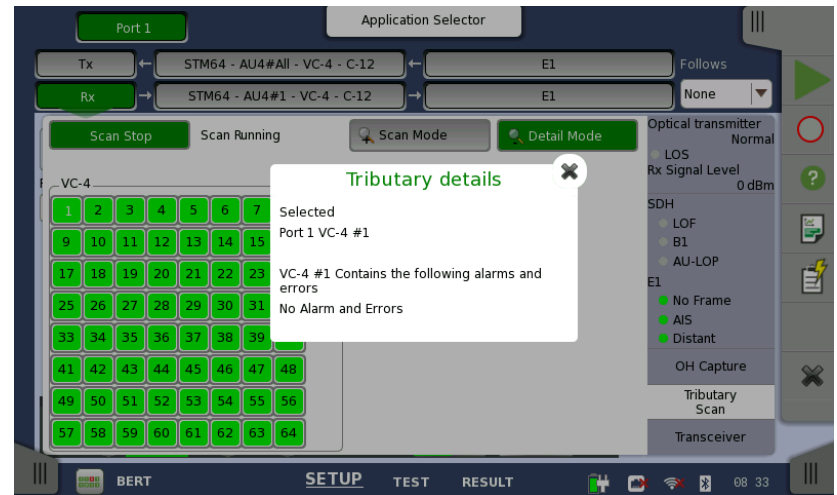

# MT1000A SDH/SONET Performance Measurements

- Bi-directional performance measurement
  - Easy information switching between two ports
- BER measurements of embedded PDH/DSn signal

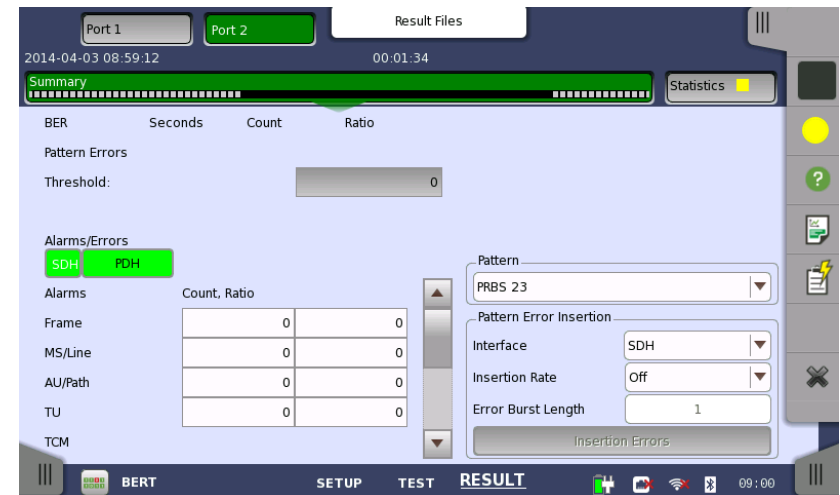
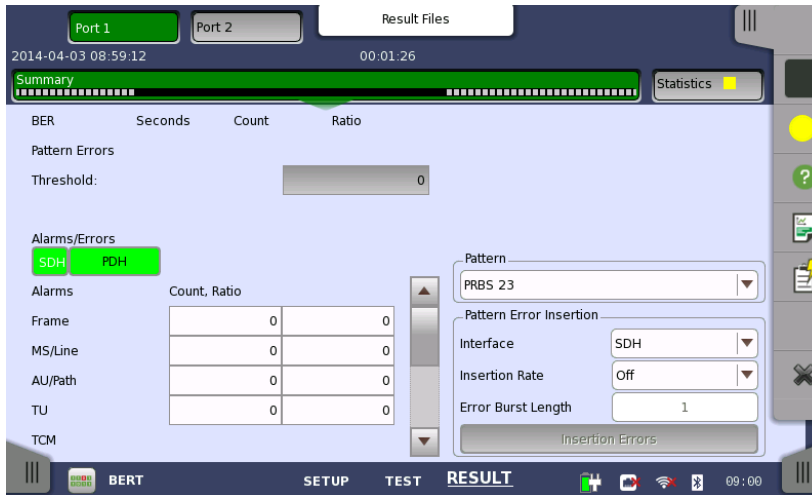

# MT1000A SDH/SONET Overhead Byte Analysis

- Bi-directional OH byte capture
- User-programmable transmitted OH bytes

The screenshot shows the 'Application Selector' window with 'Port 2' selected. The configuration includes 'STM1e - AU4#All - VC-4 - C-12' for both Tx and Rx paths. The overhead byte analysis table is displayed with columns for SOH, VC-4 POH, and VC-12 POH. The SOH section includes bytes A1 through S1, with A1 through A2 set to F6h and A3 through A6 set to 28h. The VC-4 POH section includes bytes J1 through S1, with J1 through J2 set to 00h and J3 through J4 set to 00h. The VC-12 POH section includes bytes C1 through S1, with C1 through C2 set to 00h and C3 through C4 set to 00h. The interface also shows various status indicators and a 'Pause' button.

The screenshot shows the 'SOH Editor' dialog box. The 'S1' field is set to 'xxxx0000 Quality unknown'. The 'J0' field is set to 'CRC ON' and 'Message\_Test\_J0'. The 'Idle Char' is set to '20h'. The grid shows the following values for the overhead bytes:

A1	F6h	A1	F6h	A1	F6h	A2	28h	A2	28h	A2	28h	J0	40h	..	AAh	..	AAh
B1	..	00h	..	00h	..	00h	..	00h	..	00h	..	F1	00h	..	00h	..	00h
D1	00h	..	00h	..	00h	D2	00h	..	00h	..	00h	D3	00h	..	00h	..	00h
H1	00h	H1	9Bh	H1	9Bh	H2	FFh	H2	FFh	H2	FFh	H3	00h	H3	00h	H3	00h
B2	..	B2	..	B2	..	K1	01h	..	00h	..	00h	K2	18h	..	00h	..	00h
D4	00h	..	00h	..	00h	D5	00h	..	00h	..	00h	D6	00h	..	00h	..	00h
D7	00h	..	00h	..	00h	D8	00h	..	00h	..	00h	D9	00h	..	00h	..	00h
D10	00h	..	00h	..	00h	D11	00h	..	00h	..	00h	D12	00h	..	00h	..	00h
S1	00h	..	00h	..	00h	..	00h	..	00h	M0	00h	M1	00h	E2	00h	..	00h

# MT1000A SDH/SONET Event Insertion

- Stress-test network elements by inserting events in test signal
- Inserted Events:
  - Alarms
  - Errors
  - Frequency deviations
  - Pointer operations

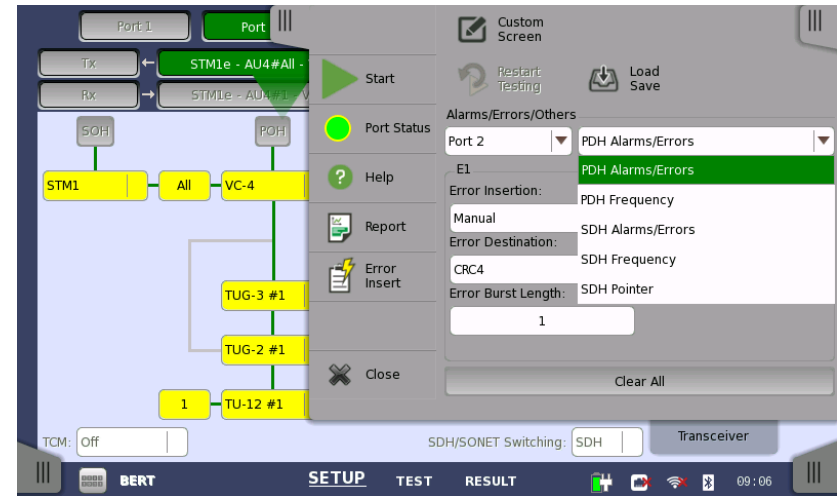

# MT1000A SDH/SONET APS Test Application

- Max switchover time measurement
  - User-defined max. time
  - User-defined switching criteria: APS measurement triggered by SDH/SONET or E1/DS1 events
  - Average time display
- APS protocol events can be generated and detected
  - No. of switchovers based on APS protocol events count
- Measurement at two receivers for simultaneous APS protocol event monitoring and switch time measurement

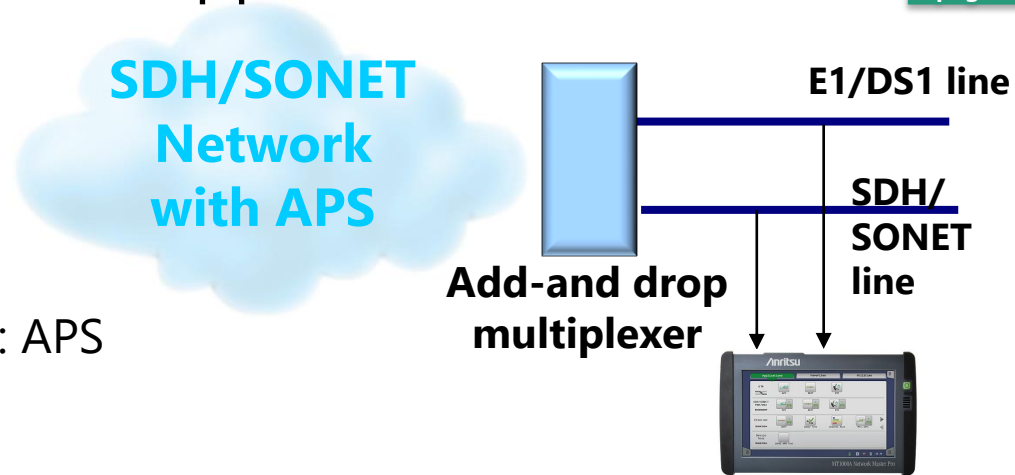

# MT1000A SDH/SONET Pointer Movement Graph

- Graph of pointer movements
  - Good overview of pointer operations
- Information on AU and TU pointer
- Magnify graph points of interest
- Results stored in MT1000A memory

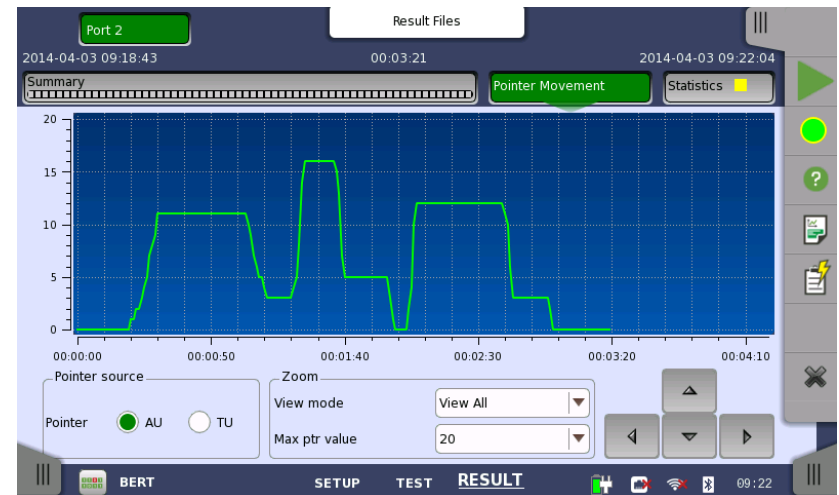

# MT1000A SDH/SONET TCM Functions

- Analyze TCM (Tandem Connection Monitoring) function in SDH/SONET systems
  - Simultaneous bi-directional monitoring of TCM information on SDH/SONET lines
  - Comprehensive TCM error and alarm statistics
  - Inject TCM events to stress-test network elements

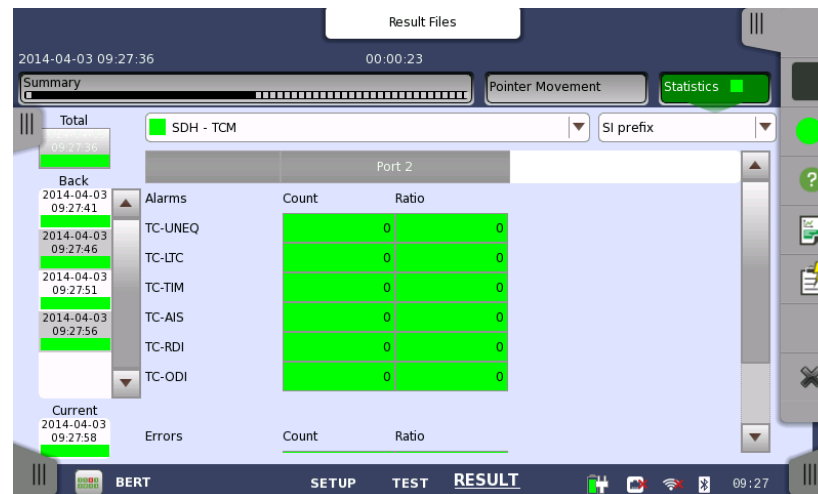

# MT1000A PDH/DSn Out-of-Service Testing

- Installing, commissioning and troubleshooting PDH/DSn lines
- Stress system by generating alarms, errors, slip and frequency offset
- Testing synchronization circuits
- G.821(E1/DS1)/G.826/M.2100 error performance
- Alarm, error, slip and frequency-deviation measurements
- Propagation time with far-end loopback

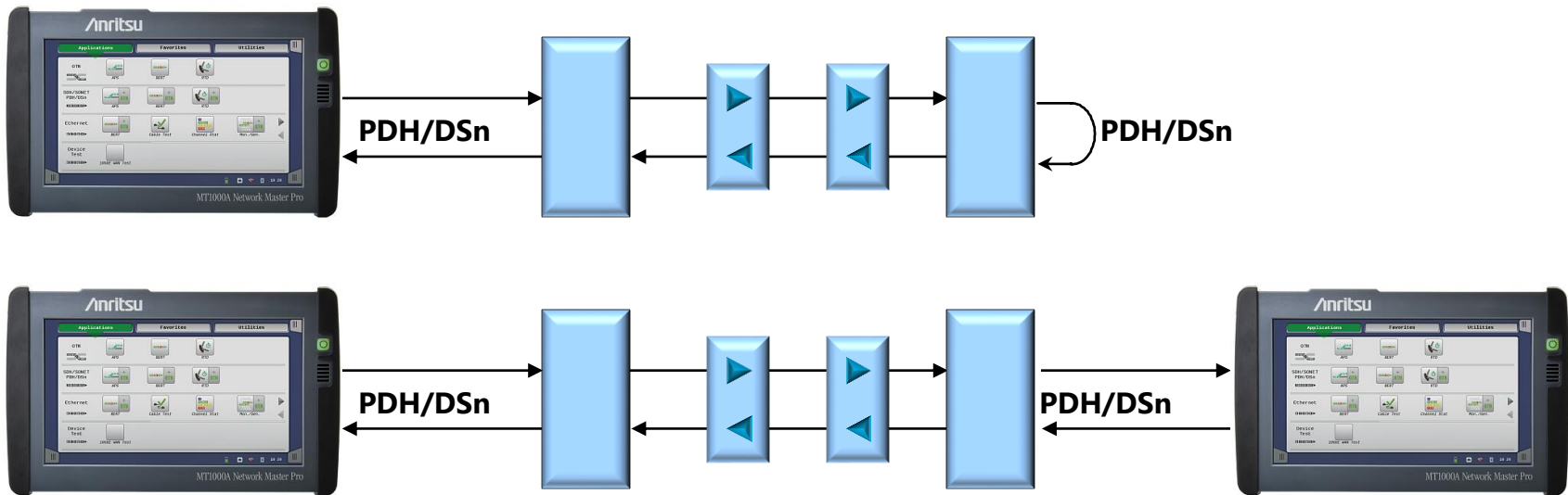



# MT1000A PDH/DSn In-Service Measurements

- Alarm and error monitoring at both sides of PDH/DSn line
- Frequency-deviation measurements
- G.821(E1/DS1)/G.826/M.2100 error-performance measurements on live traffic

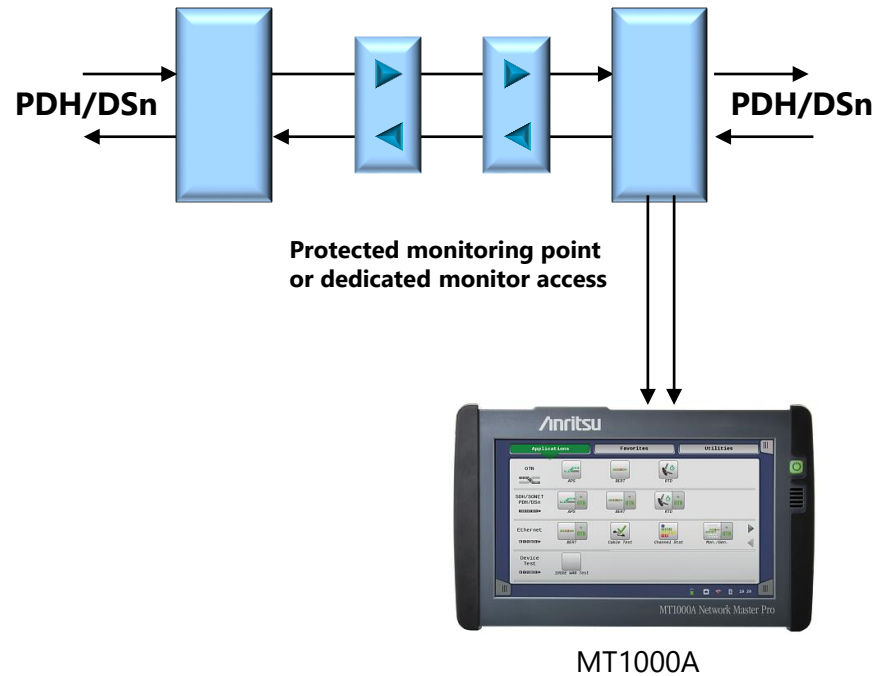

# MT1000A E1/DS1 Network-Element Testing

- Installing/commissioning
- G.821, G.826 or M.2100 error-performance measurements
- System stressing by generating alarms, errors, slip and frequency offset
- Testing synchronization circuits
- Alarm, error, slip and frequency-deviation measurements
- Propagation time measurements

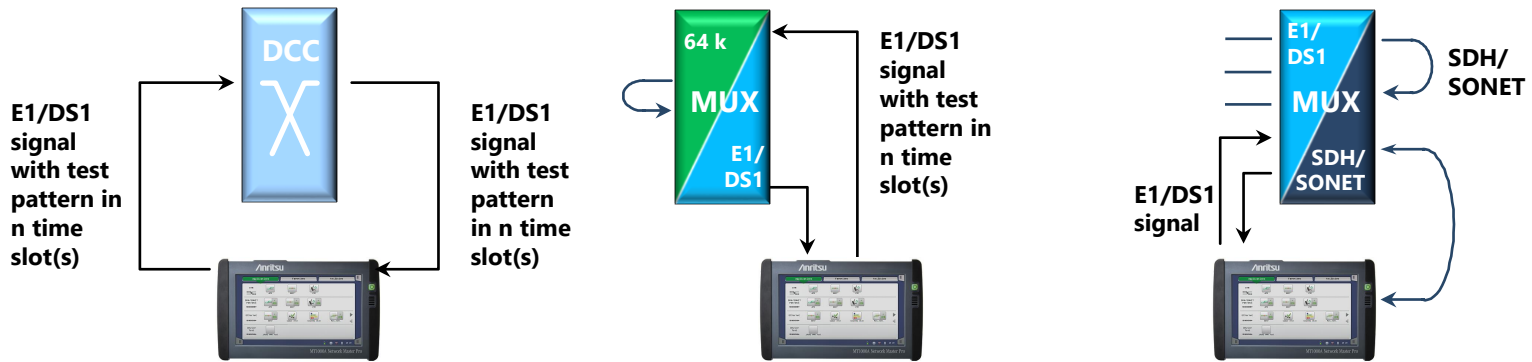

# MT1000A E1/DS1 Drop-and-Insert Testing

- Pseudo in-service testing on live PCM systems
- Add and drop  $N \times 64$  kbps signals
- Alarm, error and slip generation and measurement
- Inject errors in live traffic channel
- G.821, G.826 or M.2100 error-performance
- Frequency deviation

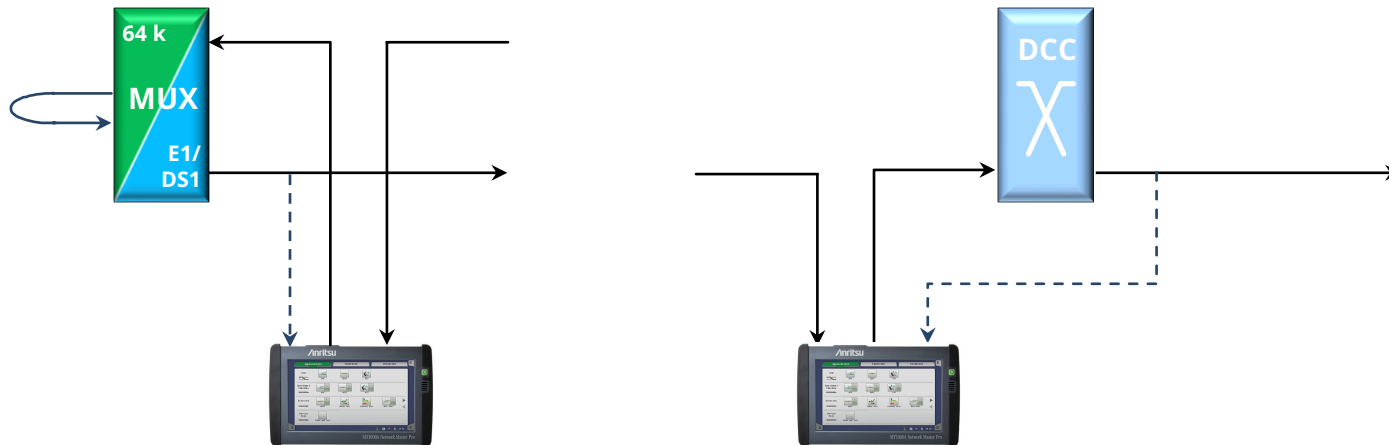

# MT1000A PDH/DSn Line Status

- Physical line information – display of current:
  - Input frequency and deviation
  - Input-level indication
  - Pattern bit rate
- Current alarms and errors

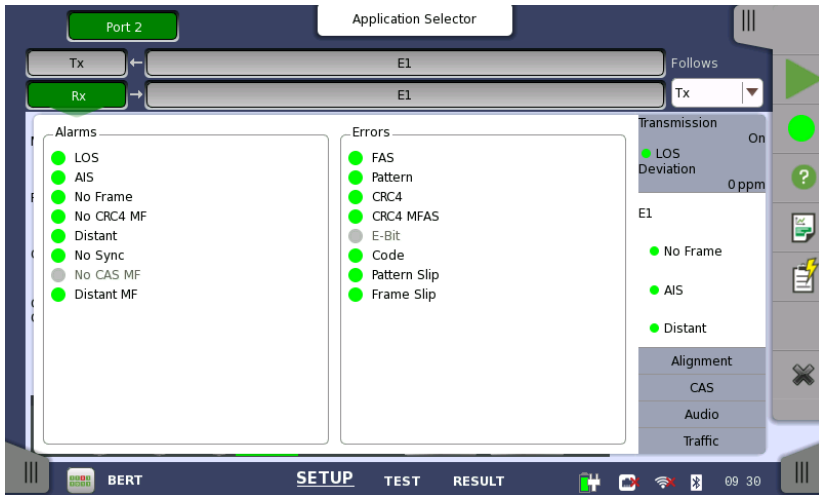
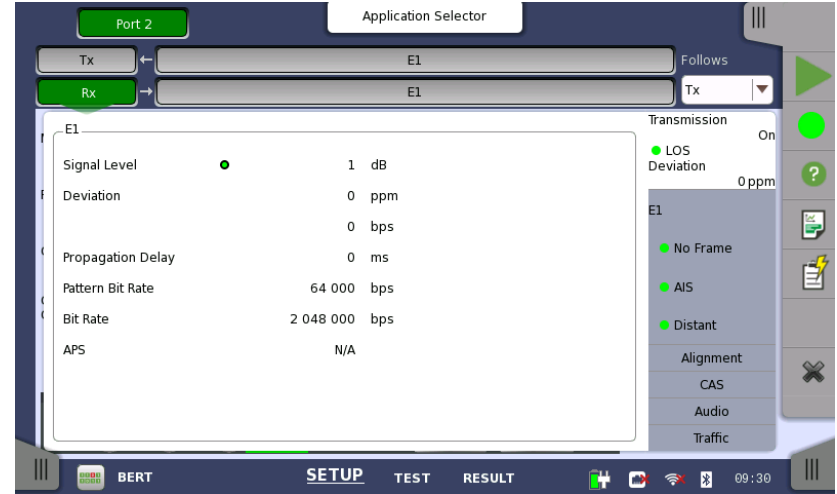

# MT1000A PDH/DSn Alarm and Error Statistics

- Alarm-second counts and ratios
- Error counts and ratios
- M.2100, G.826 or G.821 parameters
- Histograms show measurement overview
  - Click parameter to activate histogram

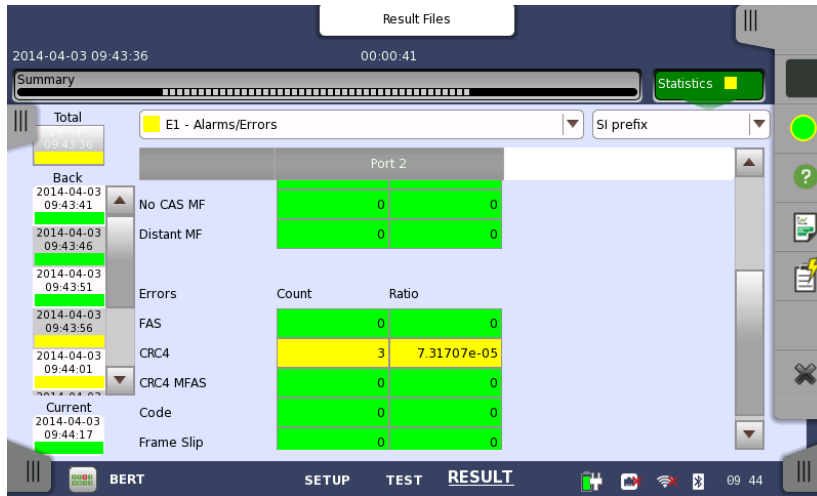

# MT1000A E1 Alignment and CAS Displays

- Information on FAS words and Sa bits

- Information on CAS bits
  - User-selectable bit pattern for red and yellow colors

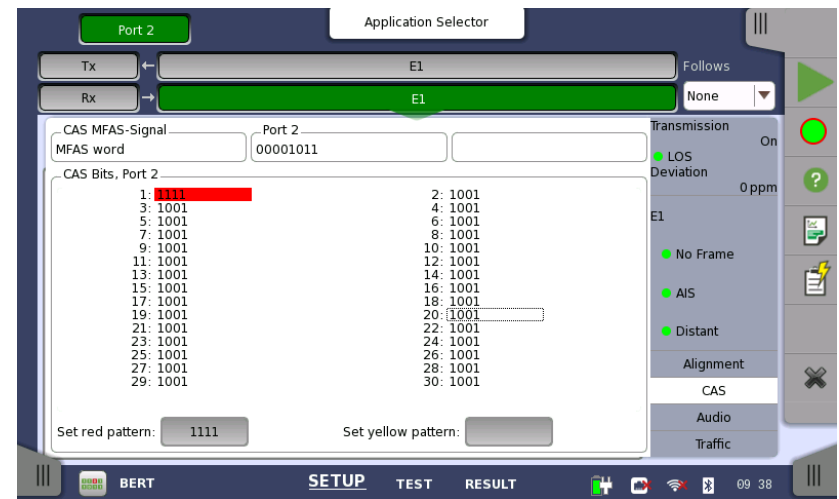
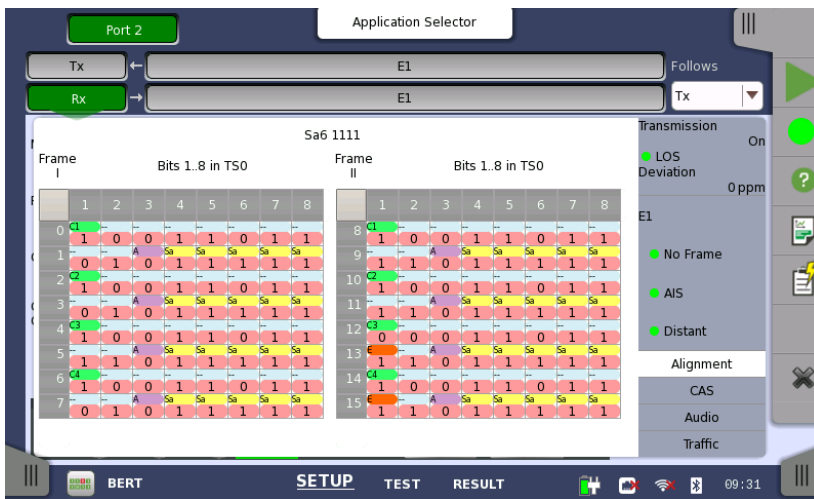

# MT1000A DS1 Alignment and CAS Displays

- Information on F-bits and S-bits
- Information on CAS bits
  - User-selectable bit pattern for red and yellow colors

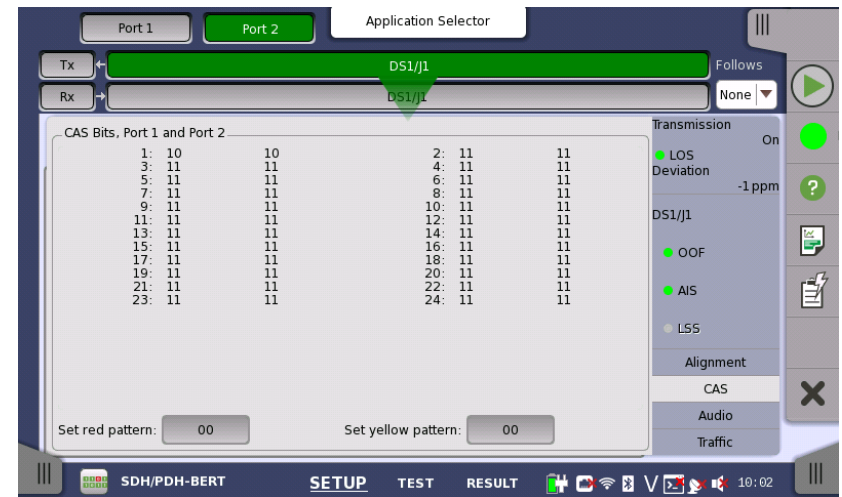
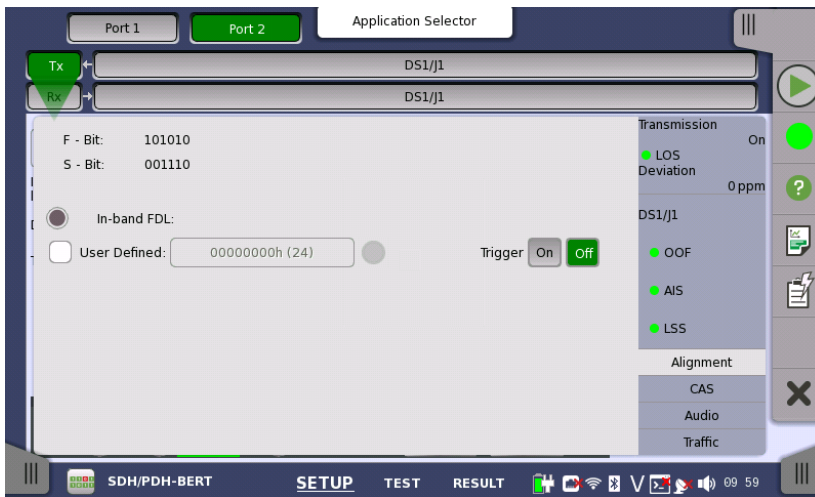

# MT1000A E1/DS1 Channel Status Display

- Fast overview of E1/DS1 line status

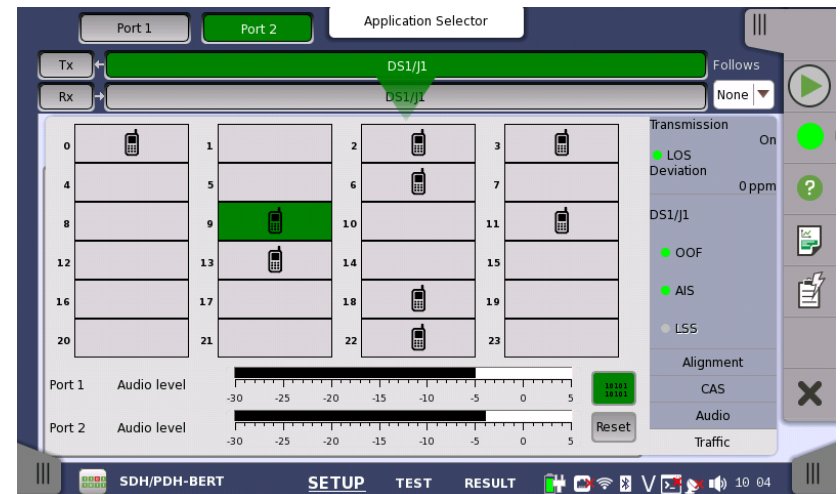
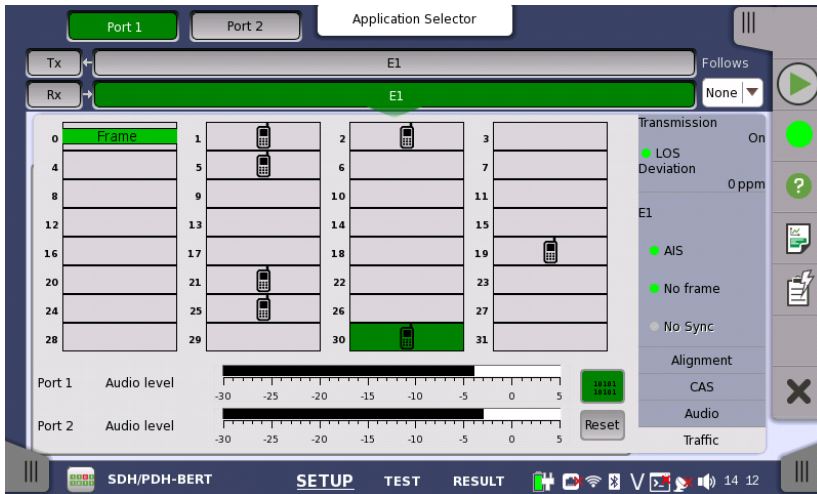



# MT1000A E1/DS1 Audio Display

- Details on contents of one selected traffic channel
  - Displays information from two ports for bidirectional monitoring

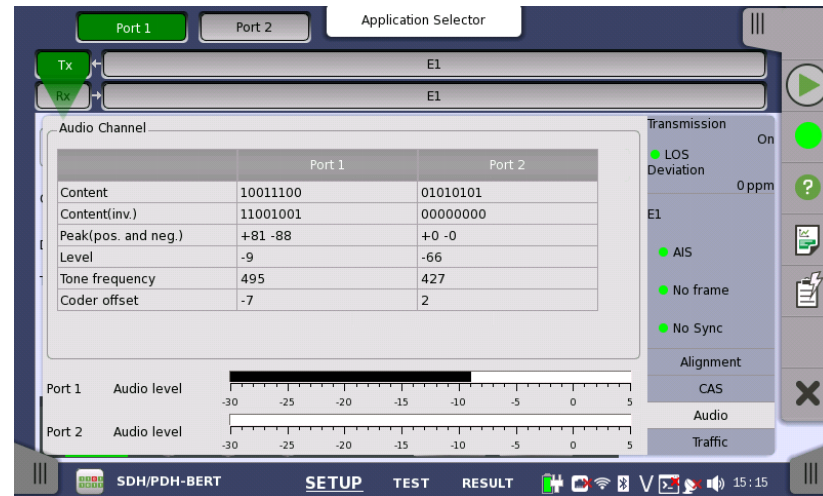

# Network Master Pro MT1000A

- VIP: Video Inspection Probe

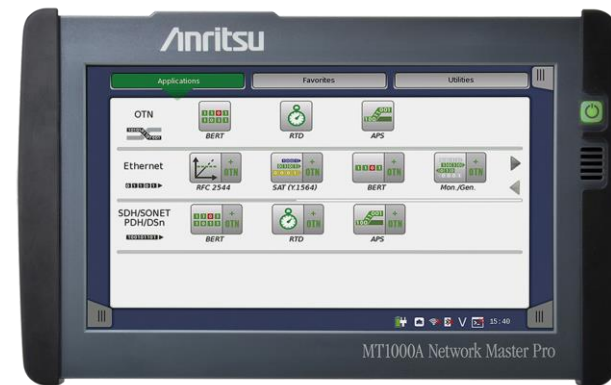

# VIP: Video Inspection Probe



- VIP Video Inspection Probe
  - Judge quality of optical fiber and module endface
  - Find trouble in optical fiber and module endface
  - Reduce degraded signal transmission and effect on measurement results
  - Prevent connected optical fiber and module endface damage
- Dirty connector endface...
  - Dirty connector endface causes more reflection
  - Cleaning connector endfaces maintains good connection
- Damaged connector endface...
  - Damaged connector endface has greater reflection and larger ORL (Optical Return Loss)
- MT1000A supports G0382A/G0306B VIP option
  - Table View identifies endface “defects” or “scratches”
  - Automatic fiber endface pass/fail determination made in accordance with IEC61300-3-35 standard

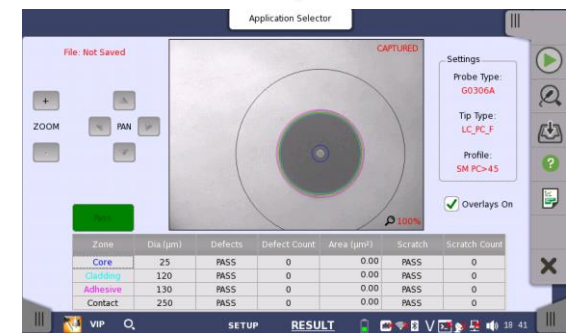
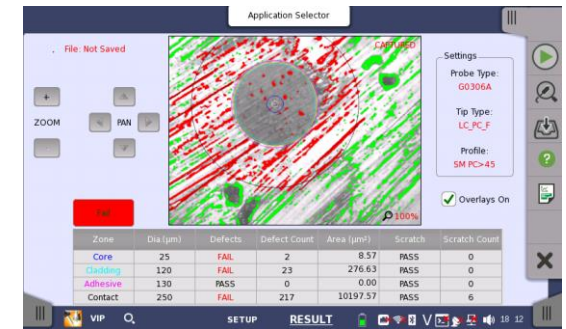

# VIP - Ordering items 1/2 -

<b>Model No.</b>			
G0382A	Autofocus Video Inspection Probe		
- Standard accessories*1 -	Soft Bag Seven Connector Tips - 1.25mm PC Male, - 2.5mm PC Male, - 2.5mm APC Male, - 1.25mm PC Female(LC), - 2.5mm PC Female(FC), - 2.5mm PC Female(SC), - 2.5mm APC Female(SC) Quick Reference Guide		
<b>Application Parts</b>			
<b>Model No.</b>		<b>Model No.</b>	
H0382A	2.5PC-M (2.5mm PC Male)	H0395A	FC-APC-F (FC APC Female)
H0383A	1.25PC-M (1.25mm PC Male)	H0385A	LC-PC-F (LC PC Female)
H0387A	2.5APC-M (2.5mm APC Male)	H0393A	LC-PC-F-L (LC PC Long Female)
H0388A	1.25APC-M (1.25mm APC Male)	H0394A	LC-APC-F-L (LC APC Long Female)
H0384A	SC-PC-F (SC PC Female)	H0396A	ST-PC-F (ST PC Female)
H0398A	SC-APC-F (SC APC Female)	H0397A	MU-PC-F (MU PC Female)
H0386A	FC-PC-F (SC PC Female)	H0390A	E2000-PC-F (E2000 PC Female)
		H0392A*2	MPO-PC/APC-F (MPO PC/APC Female)

\*1: Operation manual and MX900031A Autofocus VIP Software (For PC) can be downloaded from Anritsu public Web site.

\*2: H0392A MPO tip does not have Autofocus and Pass/Fail functions.



# VIP - Ordering items 2/2 -

<b>Model No.</b>			
G0306B	400x Video Inspection Probe		
- Standard accessories -	Operation manual (Printed) Soft Bug Seven Connector Tips - 1.25mm PC Male, - 2.5mm PC Male, - 2.5mm APC Male - 1.25mm PC Female(LC), - 2.5mm PC Female(FC) - 2.5mm PC Female(SC), - 2.5mm APC Female(SC)		
Application Parts			
<b>Model No.</b>		<b>Model No.</b>	
H0360A	2.5PC-M	H0366A	SC-APC-F
H0361A	1.25PC-M	H0372A	E2000-PC-F
H0362A	2.5APC-M	H0373A	FC-APC-F
H0363A	LC-PC-F	H0374A	MU-PC-F
H0364A	FC-PC-F	H0375A	ST-PC-F
H0365A	SC-PC-F	H0376A	1.25APC-M
		H0380A	LC65-PC-F

G0306B + Standard Accessories

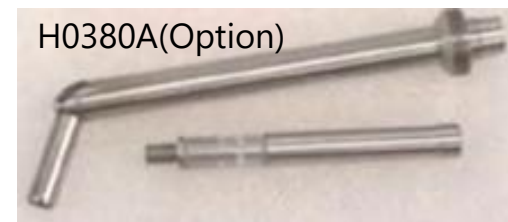
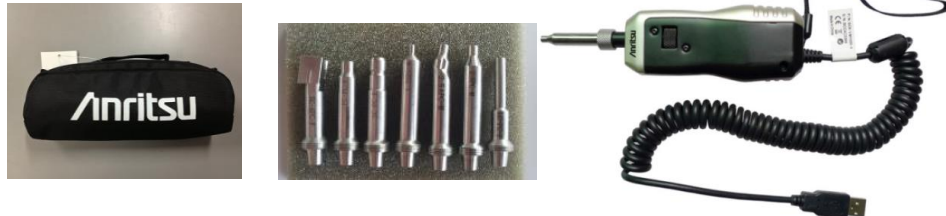

# Network Master Pro MT1000A

- Operation and Presentation

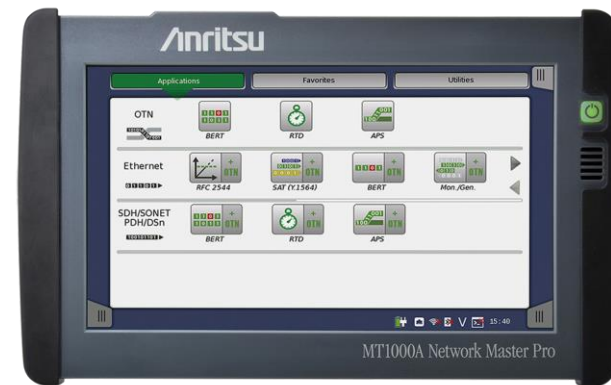

# MT1000A Operation and Presentation

- Easy operation
  - Simple, intuitive GUI
  - Loading and transferring configurations
  - Go/No Go testing
- Touch-screen based operation
- Automation Testing
- Remote operation
  - Via Ethernet interface
- Setup transfer/data transfer/firmware upgrade
  - Via USB interface

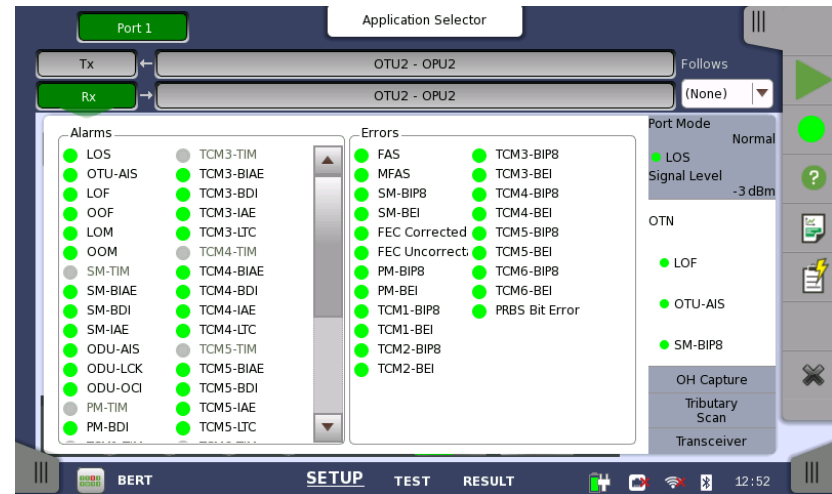

# MT1000A GUI

- Five main groups

Application Selector



Results Files



Application work space

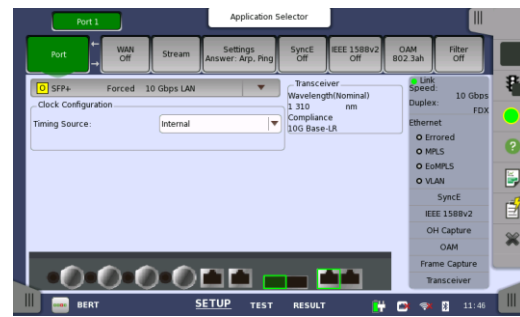

Port Setup

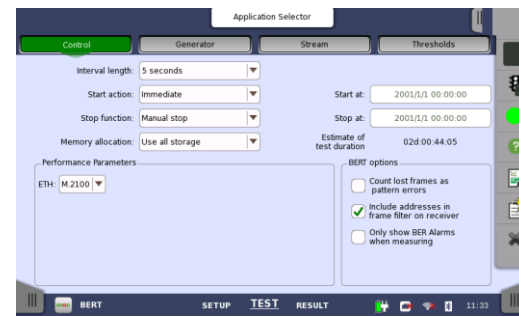

Test Setup

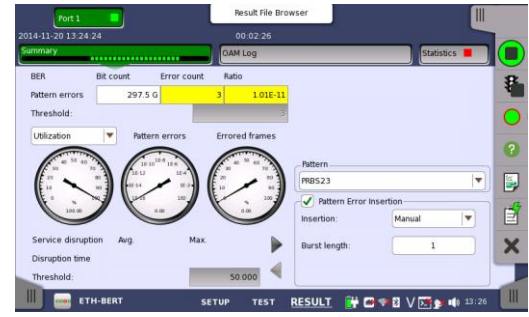

Test Results



# MT1000A GUI

- Application selector
  - Intuitive launch of new test
  - “Double” keys for starting tests of client signals in OTN
    - Right side of key starts test of client signals in OTN
    - Left side of key starts test of client signals directly

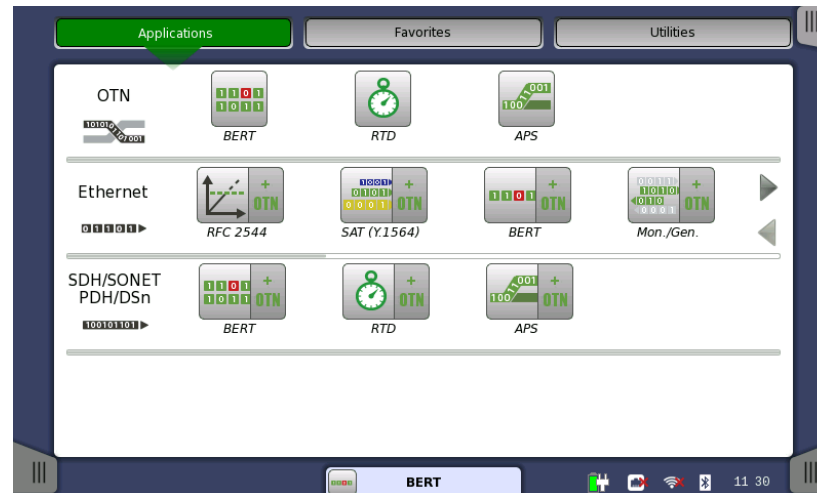

# MT1000A GUI

- Select Port display
  - Displayed after selecting application
    - Select one port – or two if available – and press Accept

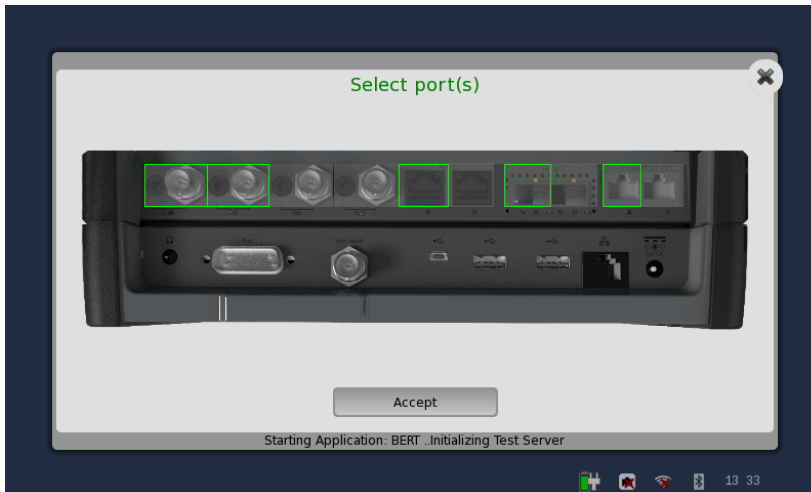

# MT1000A GUI

- Result pages:
  - Summary page
  - Event log
  - Statistics page(s)
    - Color-coded GO/NO GO indications

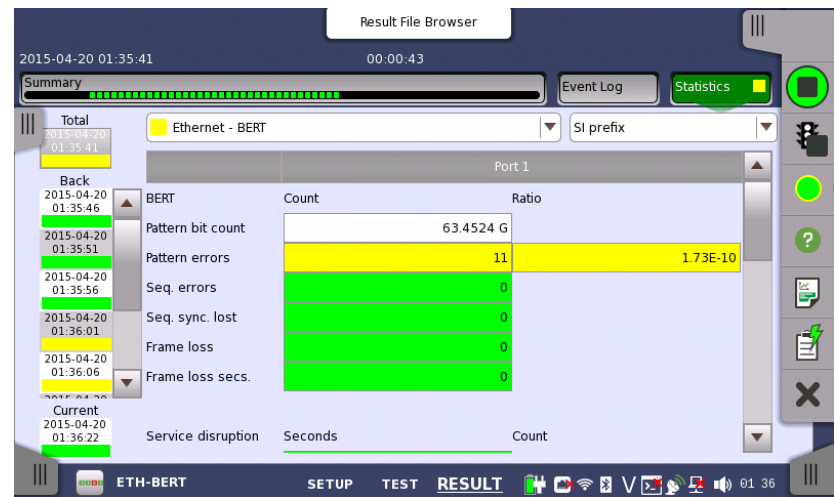
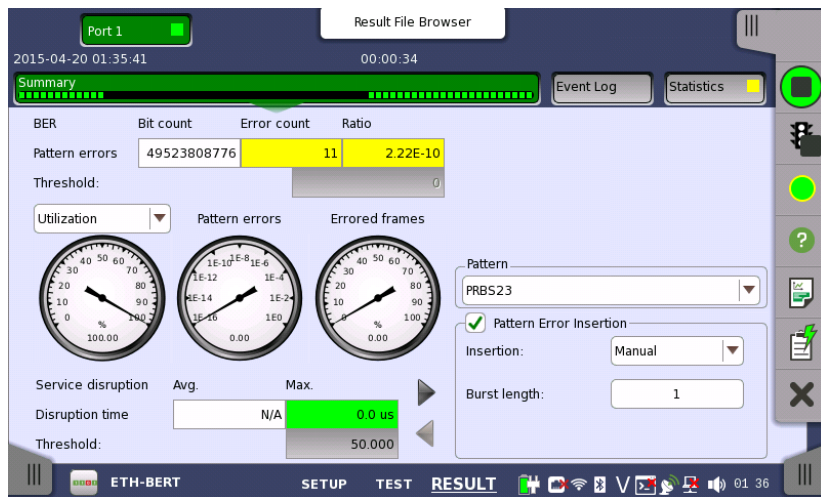

# MT1000A GUI

- Several pages in each main group
  - Selected with tabs
  - Selected from drop-down menu

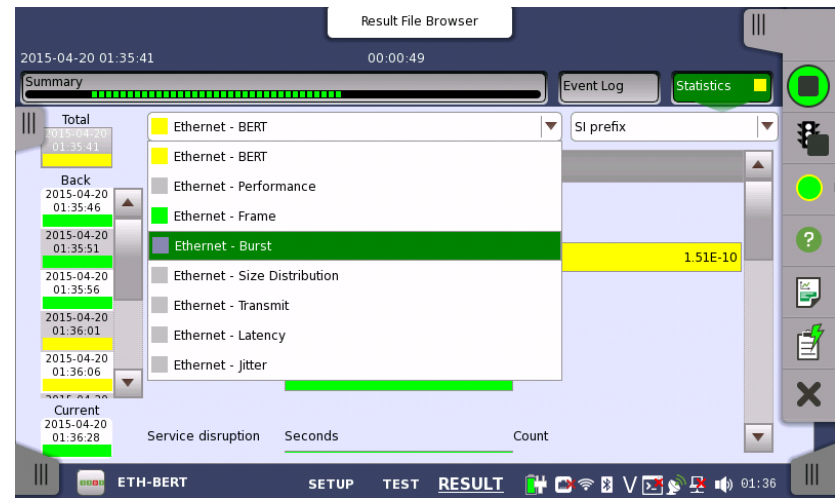
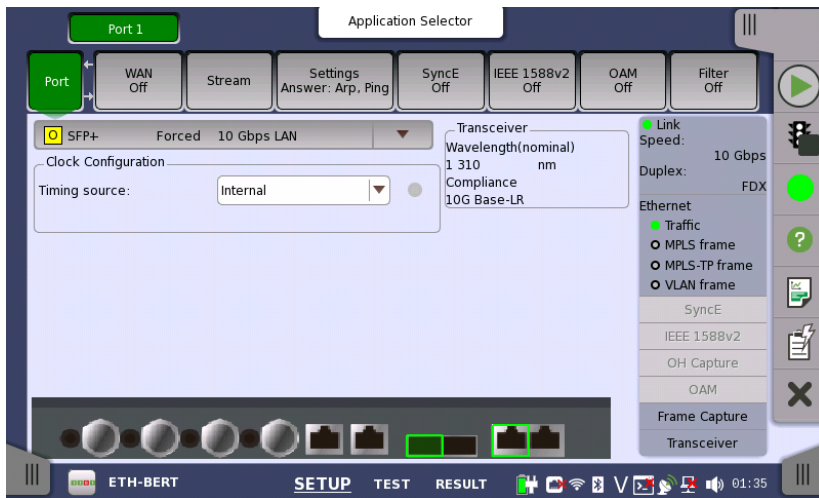

# MT1000A Histograms for General Statistics

- User sees distribution over time for selected parameter easily
  - Click parameter and select histogram
  - Click Zoom: Large numeric makes distance reading easy

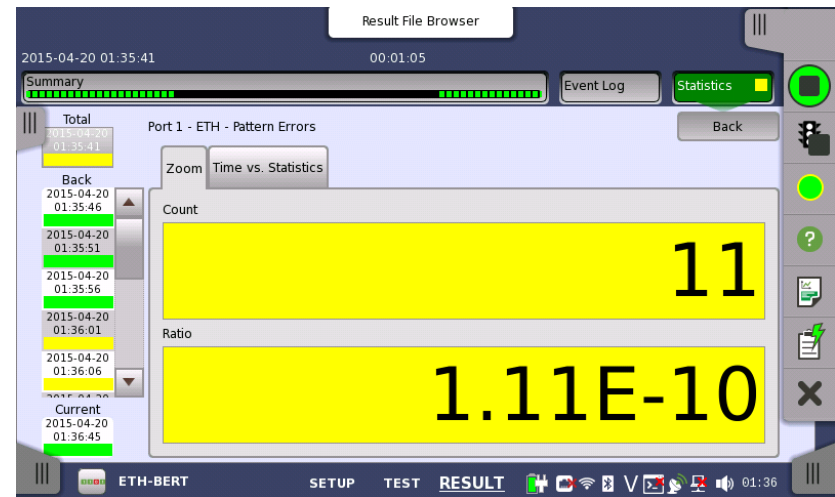
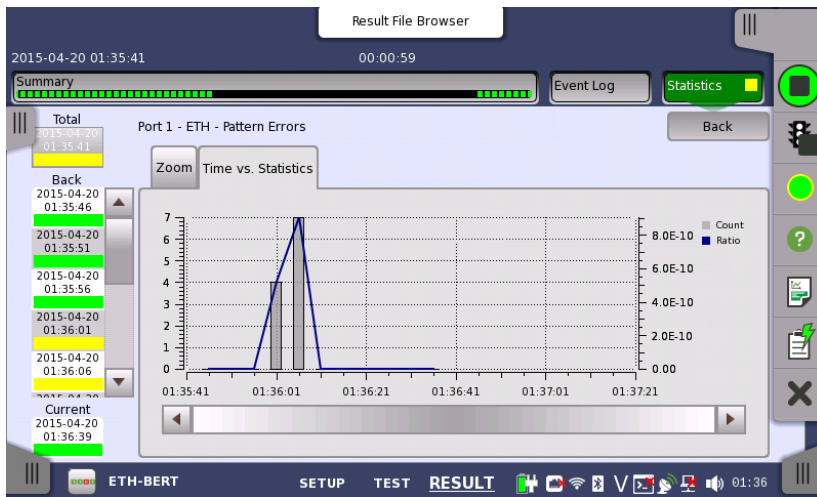

# Test Applications Summary

- Summarizes measurement results for all current Test Applications (applications using port resources) **belonging to one user** – using Remote GUI software up to two users can use MT1000A
- Test Application Summary and Overall Test Status updates only during testing:
  - Green:** No trouble
  - Yellow:** Errors (but no alarms) pending or occurred in past
  - Red:** Threshold violation or Alarms pending or occurred in past

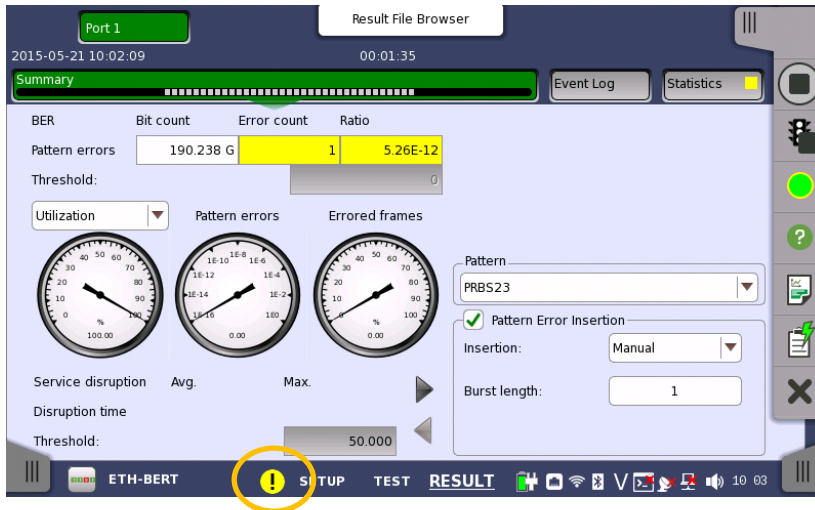

*Shows worst Status of all test applications.*



*All applications OK*



*One or more applications have Yellow Test Status (and no Red)*



*One or more applications have Red Test Status*

- Clicking Test Applications Summary icon opens Overall Test Status screen

# Overall Test Status

- For remote viewing test status for all current Test Applications
- Test Application Summary and Overall Test Status has no current/history distinction—basically show history.
- To “clear” Test Status: Restart test.
- User-configurable to show Test Application Summary indicator—and to access Overall Test Status screen

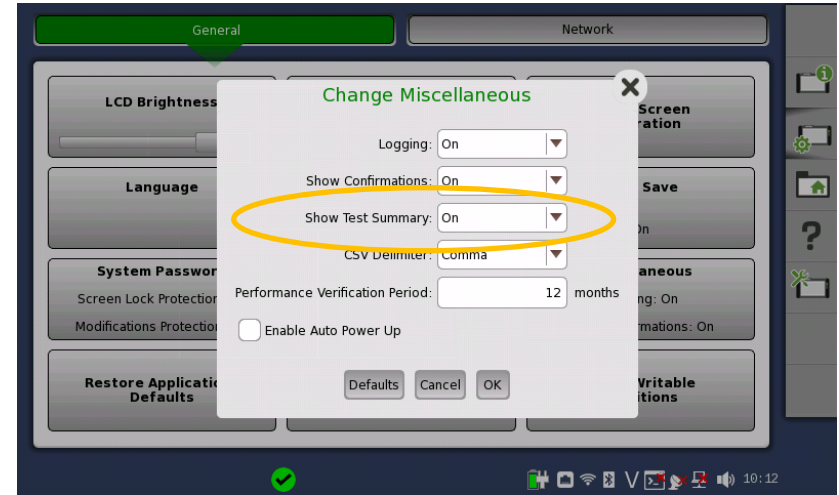
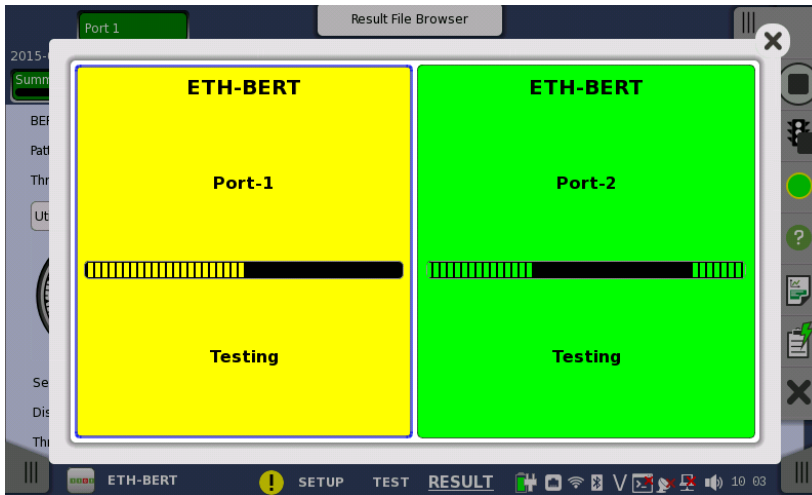

- Overall Test Status updates only during testing:
  - **Green:** No trouble
  - **Yellow:** Errors (but no Alarms) pending or occurred in past
  - **Red:** Threshold violation or Alarms pending or occurred in past

# Overall Test Status

- Adapts to number of running test applications

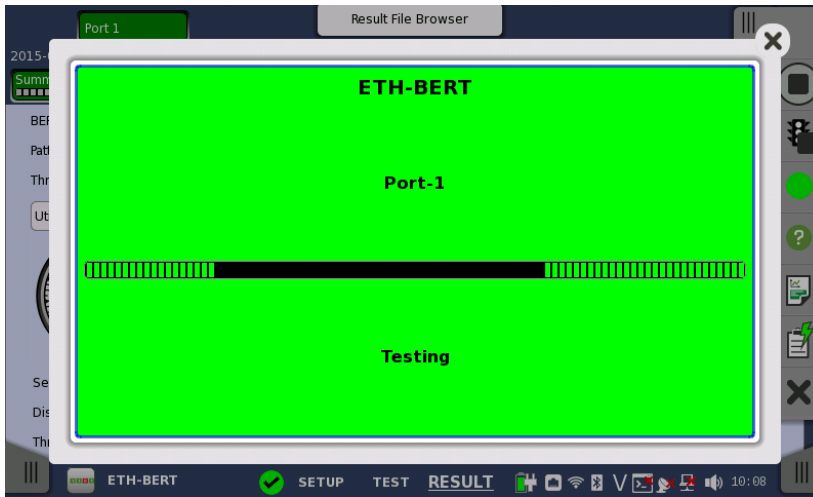

One test application

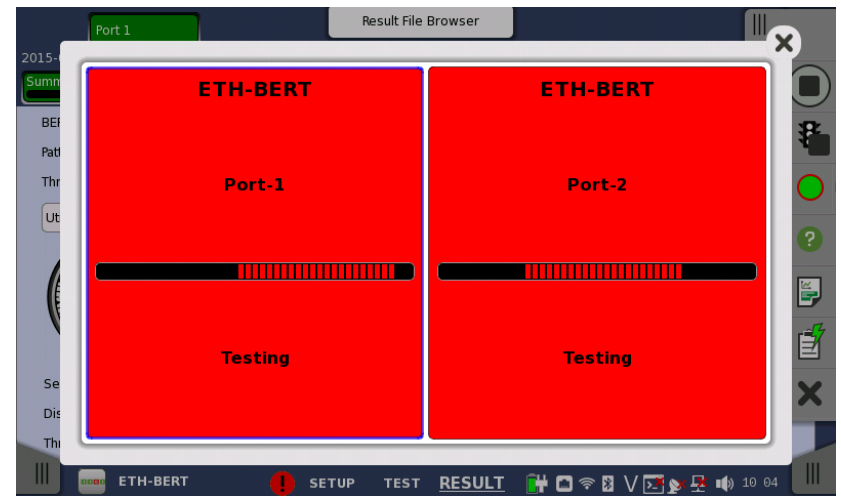

Two test applications



# Event Log

- Event Log gives users powerful means to analyze problems of long-term testing
- Records what/when problem happened and how long/often been happening

Result File Browser

2015-03-28 07:34:03 00:05:48

Summary Event Log Statistics

Filter View: All ports CSV export

No.	Time	Port	Type	Src.	Description	Dur./Count
32	2015-03-28 07:37:06	1	●	ETH	Link	00:00:09
33	2015-03-28 07:37:06	1	●	ETH	Invalid blocks	14
34	2015-03-28 07:37:07	1	●	ETH	Frame Loss Secs.	00:00:09
35	2015-03-28 07:37:15	1	●	ETH	Seq. Sync. Lost	00:00:01
36	2015-03-28 07:37:15	1	●	ETH	Pattern Errors	311
37	2015-03-28 07:37:15	1	●	ETH	Invalid blocks	2.451 k
38	2015-03-28 07:37:15	1	●	ETH	Preamble violations	260
39	2015-03-28 07:37:15	1	●	ETH	Rx FCS Errored Frame	634
40	2015-03-28 07:37:15	1	●	ETH	Fragmented	82

ETH-BERT SETUP TEST RESULT 07:39

# Event Log

- GUI filter function and CSV export

The screenshot displays a web-based interface for managing event logs. At the top, there are tabs for 'Summary', 'Event Log' (which is active and highlighted in green), and 'Statistics'. Below the tabs, there are several filter and export options:

- Filter:** A checked checkbox with a 'Clear filter' button next to it.
- Event:** A checked checkbox with a dropdown menu set to 'Exclude specific event(s)'. Below this is a 'Specify' button and a list of event types: 'ETH 10G LFS Remote Fault', 'ETH Fragmented', and 'ETH Frame Loss'.
- Time format:** A dropdown menu set to 'Absolute'.
- Number range:** A checked checkbox with 'From:' and 'To:' input fields containing '1' and '100' respectively.
- Date/Time range:** A checked checkbox with 'From:' and 'To:' input fields containing '2001-01-01 00:00:00' and '2001-02-01 00:00:00' respectively.
- CSV export:** A button with a blue arrow pointing to the right, towards a file icon.

On the right side of the interface, there is a table with a header 'Dur./Count' and a scrollable area below it.



# Event Log

- Logged events included in report

**Report Generator**

Include Results

- Summary
- Statistics (Total interval)
- Event log
- Filtered



2015-03-28 07:55:53

## Event Log

No.	Time	Port	Type	Src.	Description	Dur./Count
1	2015-03-28 07:41:40		Test	Test	Started	
2	2015-03-28 07:41:49	1	Alarm	ETH	10G LFS Remote Fault	00:00:03
3	2015-03-28 07:41:49	1	Error	ETH	Invalid blocks	73.566 k
4	2015-03-28 07:41:50	1	Alarm	ETH	Frame Loss Secs.	00:00:03
5	2015-03-28 07:41:51	1	Error	ETH	Invalid blocks	22
6	2015-03-28 07:41:52	1	Alarm	ETH	Seq. Sync. Lost	00:00:01

# Event Log

- Time stamp shows relation between event and statistics

No.	Time	Port	Type	Src.	Description	Dur./Count
1	2015-03-28 07:41:40			Test	Started	
2	2015-03-28 07:41:49	1	●	ETH	10G LFS Remote Fault	00:00:03
3	2015-03-28 07:41:49	1	●	ETH	Invalid blocks	73.566 k
4	2015-03-28 07:41:50	1	●	ETH	Frame Loss Secs.	00:00:03
5	2015-03-28 07:41:51	1	●	ETH	Invalid blocks	22
6	2015-03-28 07:41:52	1	●	ETH	Seq. Sync. Lost	00:00:01
7	2015-03-28 07:41:52	1	●	ETH	Pattern Errors	72
8	2015-03-28 07:41:52	1	●	ETH	Invalid blocks	5.763 k
9	2015-03-28 07:41:52	1	●	ETH	Preamble violations	5

2015-03-28 07:41:51



2015-03-28  
07:41:51

2015-03-28 07:41:40 00:01:57

Summary

Event Log Statistics

Ethernet - Transmit Si prefix

Port 1

	Tx	Rx
Frames	14.4442 M	0
Bytes	924.427 M	0
Unicast	14.4442 M	0
Multicast	0	0
Broadcast	0	0
Errored	0	0
FCS errored	0	0
64-127	14.4442 M	0

# MT1000A GUI

- Control panes
  - Control applications in work space

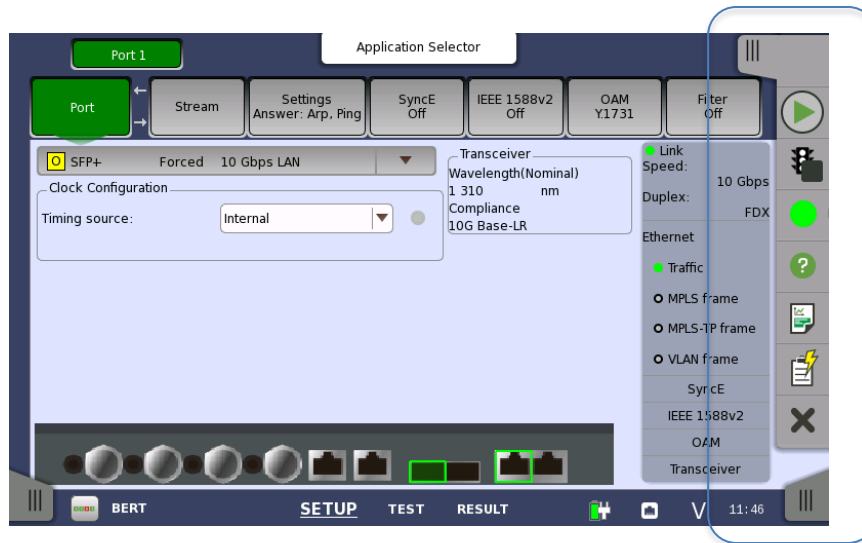

# MT1000A GUI

- Control panes
  - Control applications in work space
    - Click to expand

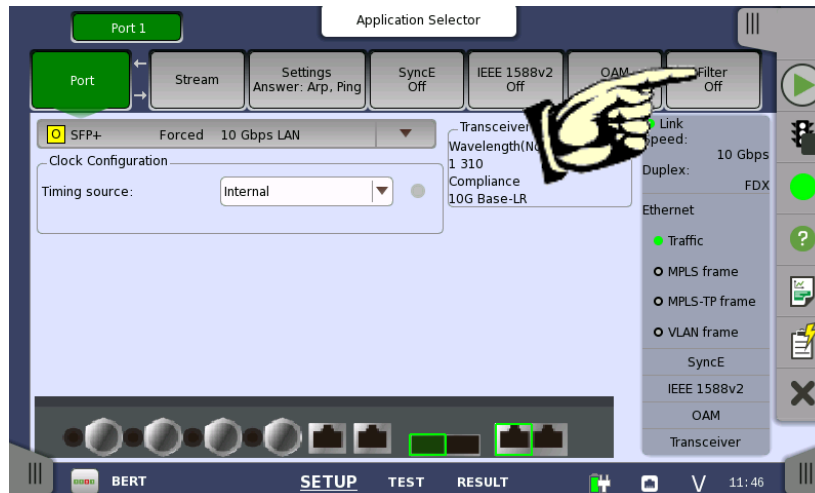

# MT1000A GUI

- Control panes
  - Control applications in work space – expanded

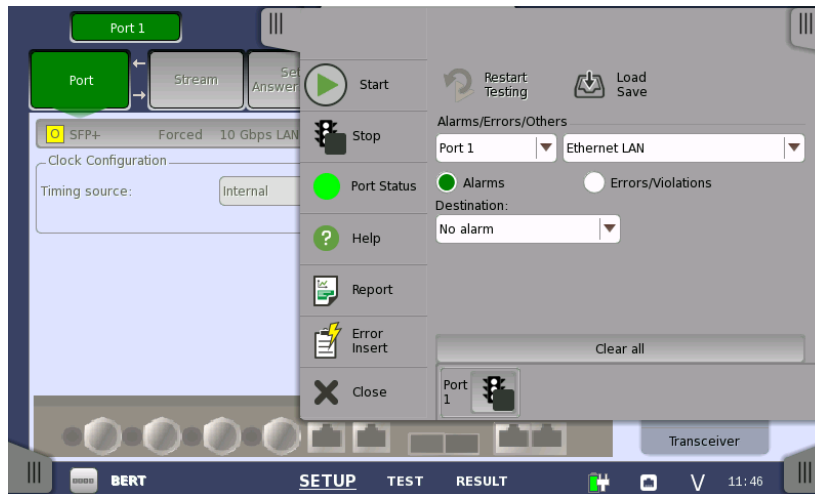

# MT1000A GUI

- Control panes
  - Control instrument in application work space – expanded
    - Click to expand instrument control

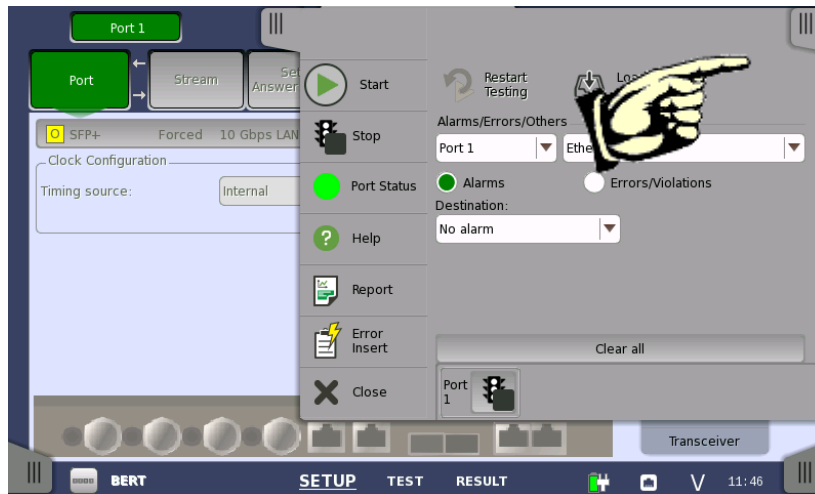



# MT1000A GUI

- Control panes
  - Control instrument in application work space



# MT1000A GUI

- Control panes
  - Control instrument in Application selector and test Result pages



# MT1000A GUI

- Power button menu

- Pressing Power button

- while instrument on displays menu to:

- Switch applications (when two applications running)
      - Take screen shot
      - Activate screen lock – can be password protected
      - Power-down



- Switch applications by clicking running applications at screen bottom
  - Running applications window always accessible

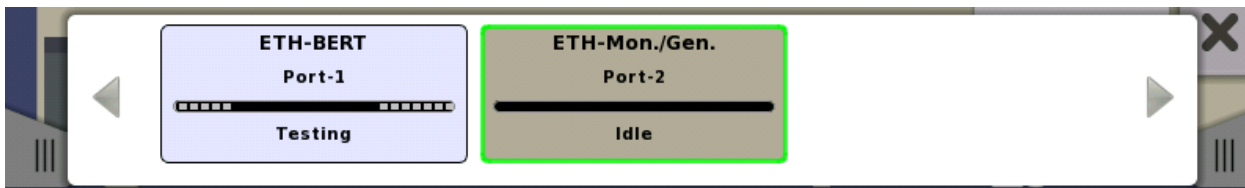

# MT1000A Instrument Setup

- Password protection
  - Prevent unintended changes to parameters and measurement start/stop
  - Enabled/disabled by user



# Network Master Pro MT1000A

- Report Generation

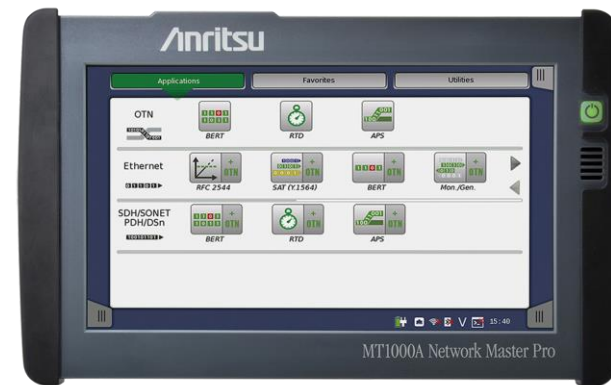

# Report Generator

- Generates reports:
  - Summary page only
  - Summary and Statistics pages
  - Port setup and Application setup included as option
  - User-customized report including:
    - Logo in .png format
    - Customer ID, Operator ID, notes, and similar information in measurement .pdf reports
  - Output report in .pdf, .CSV or .XML format to USB port

## Document Information

Report Name	BERT
Customer	Customer 001
Project	Testing of line 1
Operator	Operator 001
Notes	This is a sample report

Module Type	Serial no	Software Version
MT1000A	6D60000101	3.01
MU100010A	6D60000087	

# Report Layout

- Look of pages like Ethernet stats, event log and port settings



PDF reports are displayed with the built-in PDF viewer

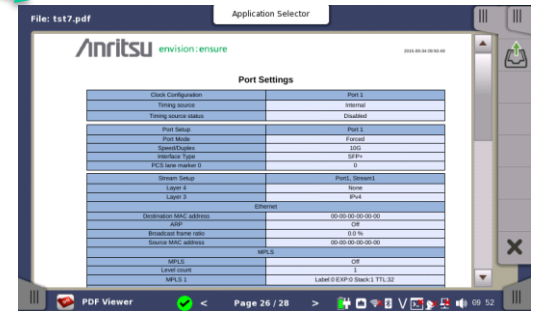
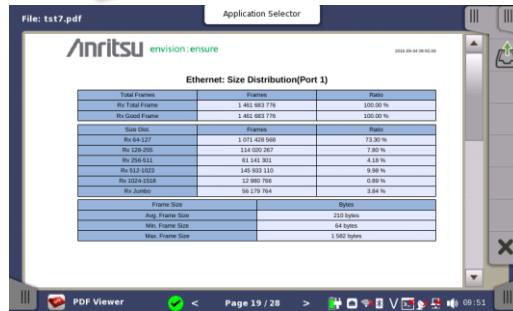

- Look of reports from other applications.

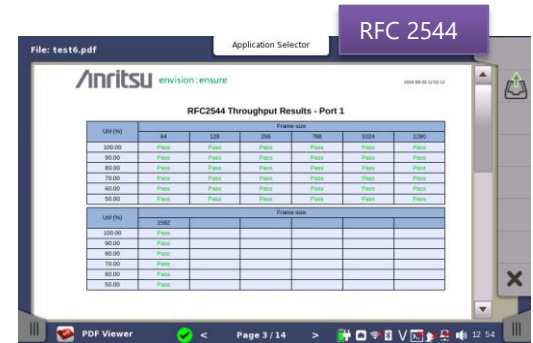
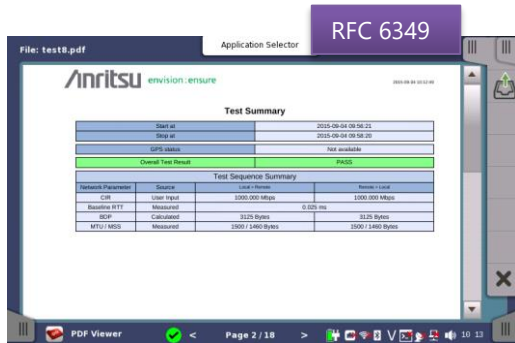

- Reports can be viewed in the built-in PDF viewer immediately after they are generated
  - This makes it simple and easy for the user to inspect the report

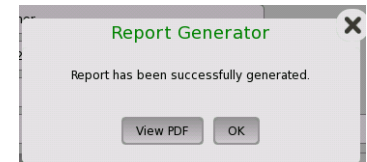



# Filtering Results Display at Report Output

- The user can select the information to output when reporting statistical test results. As a result, file save times are shortened and files sizes are smaller.

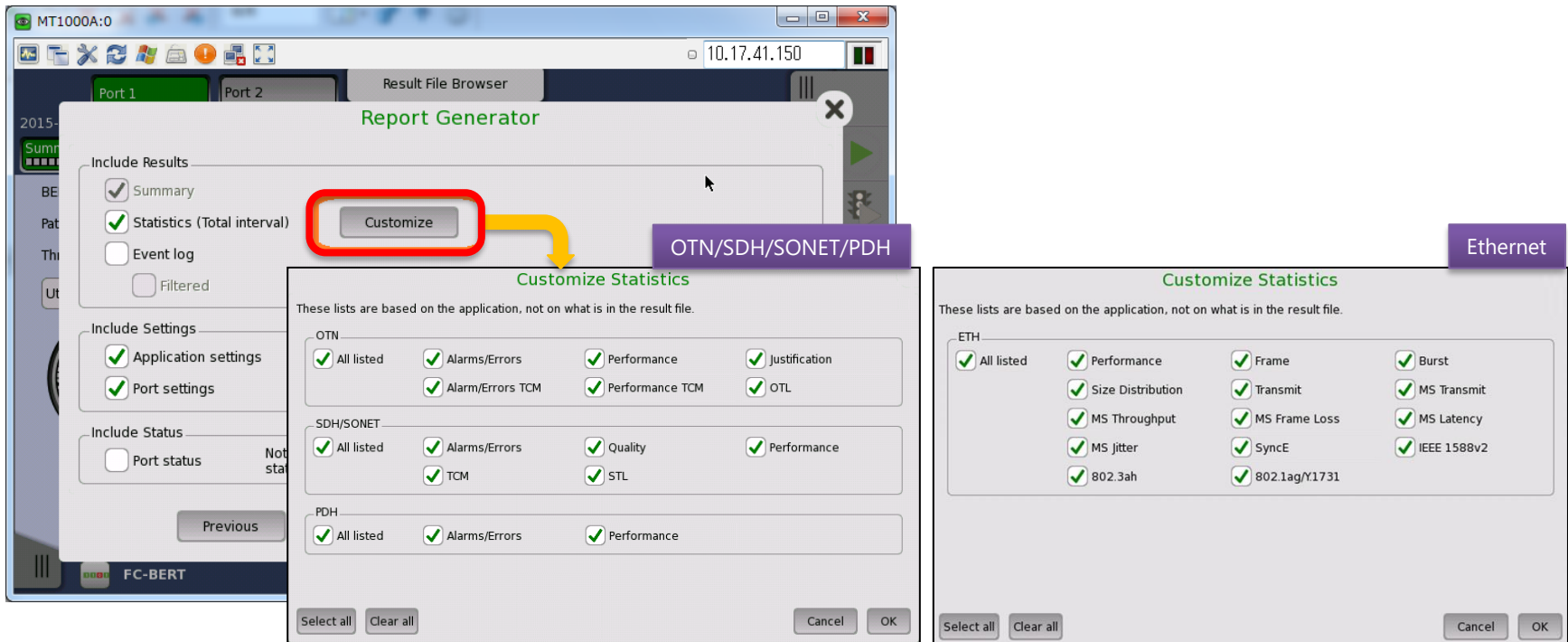

# Report Generator

- Optionally includes Performance Verification information in reports
  - User-programmable performance verification period

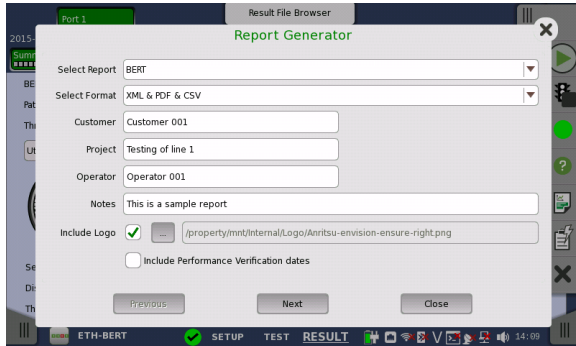

2015-05-26 14:11:03

## Document Information

Report Name	BERT
Customer	Customer 001
Project	Testing of line 1
Operator	Operator 001
Notes	This is a sample report

Module Type	Serial no	Performance Verification Date	Performance Verification Due Date	Software Version
MT1000A	6D60000101	2014-05-06	2016-05-06	3.01
MU100010A	6D60000087	2014-05-06	2016-05-06	

# Network Master Pro MT1000A

- Automation Testing

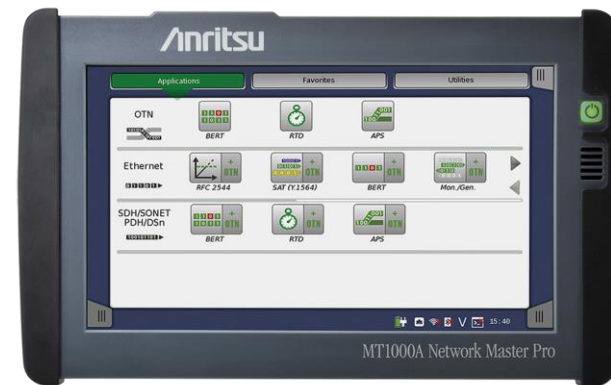

# Network Master Pro MT1000A

- Remote Operation

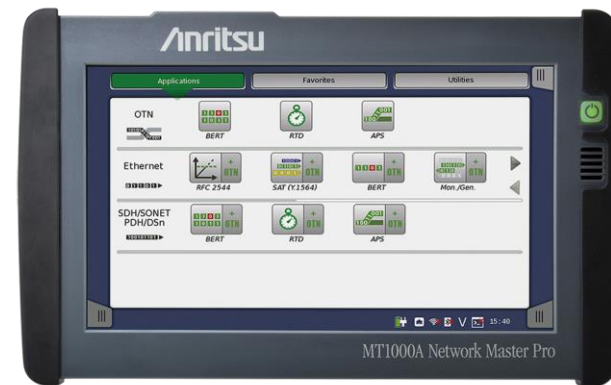

# Three Remote Control Types

	Function	Multi-user	File Sharing
VNC	Control from remote site	No	No
Remote GUI (MX100001A)	Control from remote site Port sharing File sharing	OK	OK
SCPI	Automation Control from remote site	OK	OK

# MT1000A Remote Operation – Applications

- Remote access
- Troubleshooting spurious errors
- Long-term surveillance and stability tests
- Multi-site surveillance
- Multi-user access
- Display screens via projector
- Documentation and training
- Operate MT1000A from PC with VNC client or new Remote GUI app
- View MT1000A displays on PC

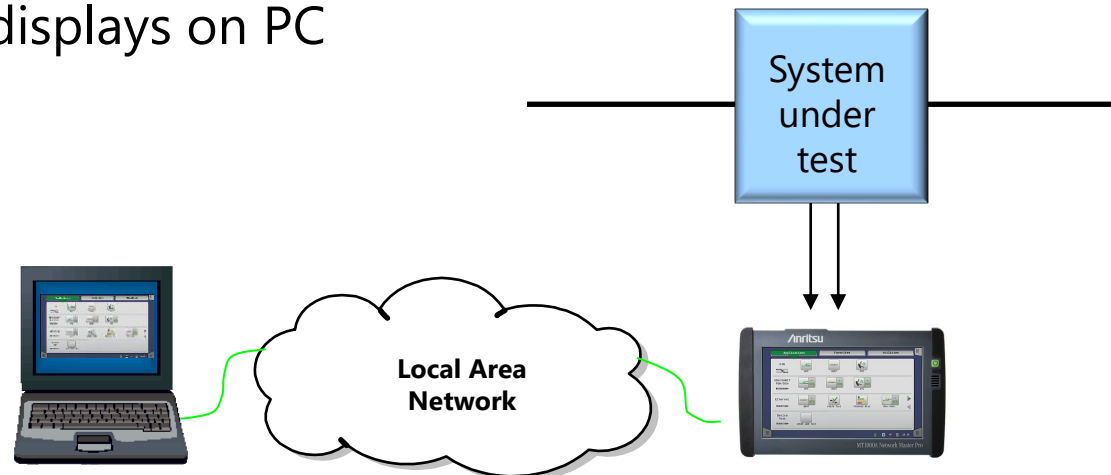

# What Can User Do with Remote GUI?

- Remote GUI application runs on Windows 7/8/8.1
- Port-oriented connection not unit-oriented
- Multiple users share same unit and use separate ports

User 1 is using Port 1



User 2 is using Port 2



DUT for User 1

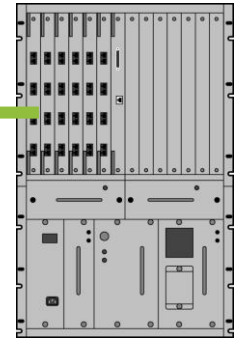

DUT for User 2

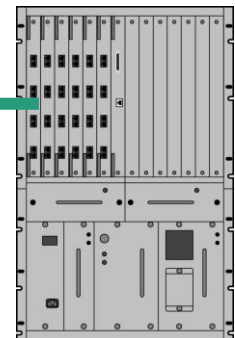

# What Can User Do with Remote GUI?

- Connect one application to up to two GUIs

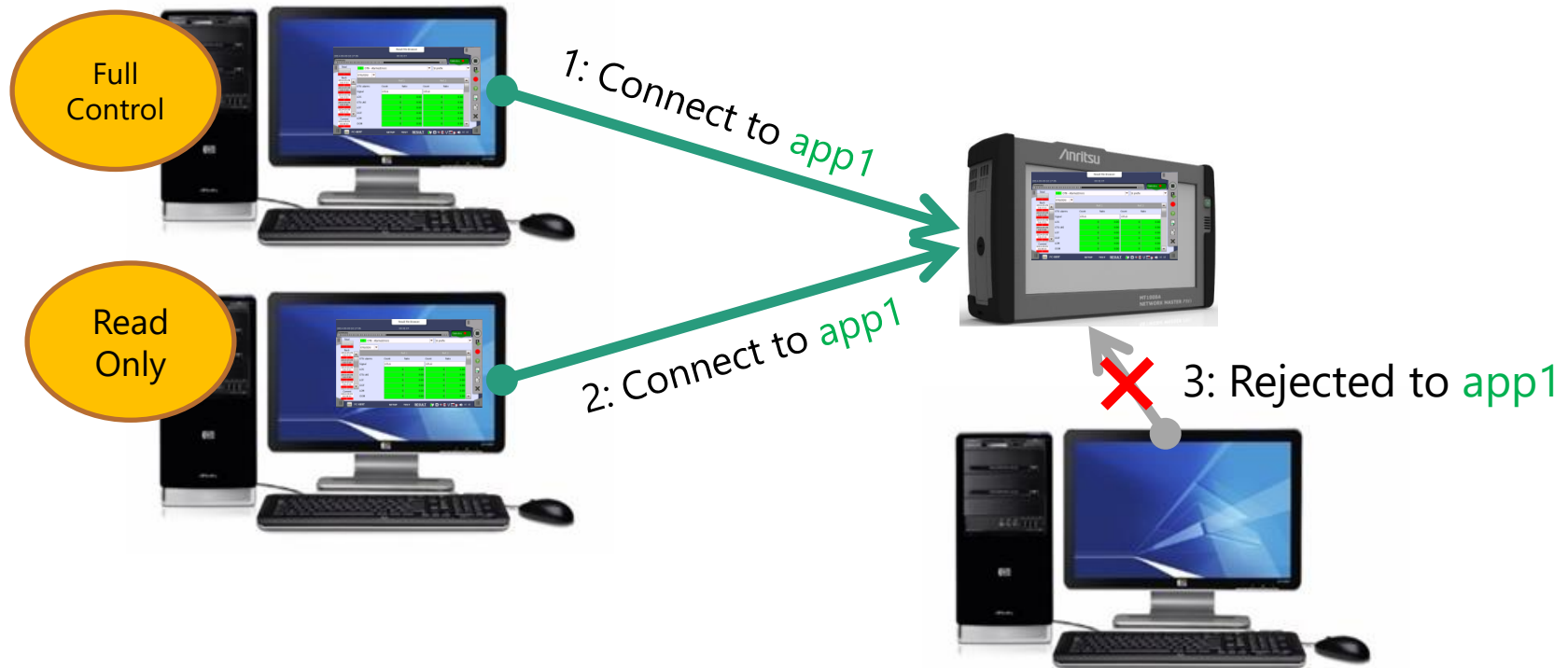

- Only one GUI can change settings and start test (Read/Write)
- Next user just observes (Read only)
- Any user can take right to change settings with exchangeable rights



# What Can User Do with Remote GUI?

- Remote GUI can run as 'Standalone' viewer
- Users can:
  - Generate report(s)
  - Analyze results offline
  - Create setup file(s) for deployment
- Remote GUI supports
  - Firmware update via LAN
  - Remote unit reset



# What Can User Do with Remote GUI?

- Share file system—user can access file system from Windows Explorer
- Access PC file system—user can save/load file to/from Windows memory

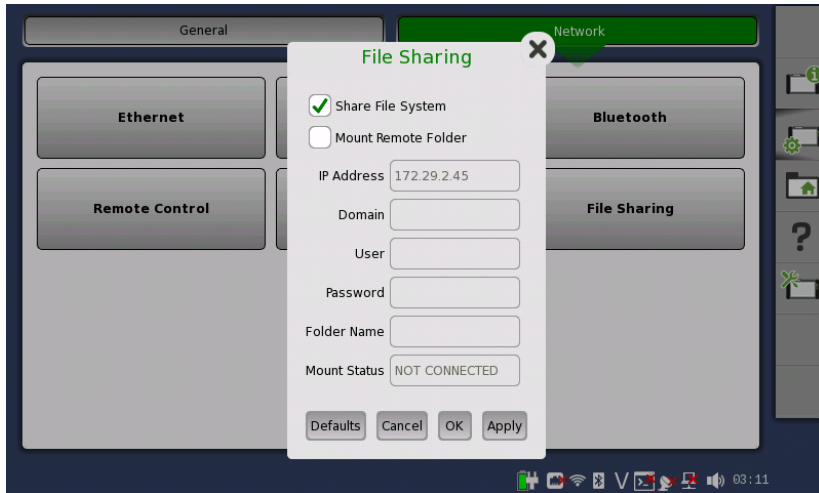

- Remote GUI supports:
  - Firmware update via LAN
  - Remote unit reset

Result files  
 Setting files  
 Report files  
 Capture files

# Network Master Pro MT1000A

- Remote Control–Scripting

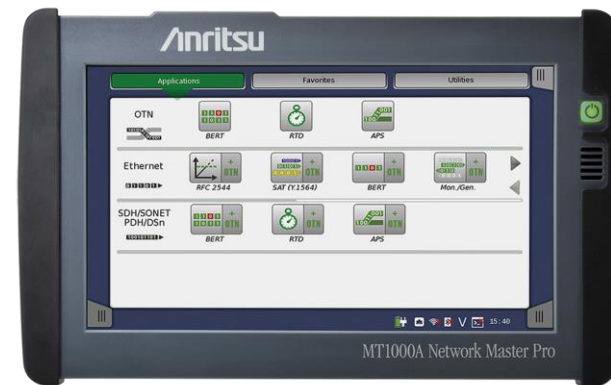

# Remote Control Scripting Option

- Automated testing for developing applications
- Remote control commands/replies as ASCII format strings
  - SCPI 1999.0 compliant with IEEE 488.2 mandatory common commands
- Fast command response
  - Execute up to 8 commands per second
    - Reduces test time at mass production
- Communication between controller (PC) and MT1000A:
  - Via MT1000A Ethernet Service Interface
    - TCP/IP connection
      - Test facility can be isolated LAN
    - Via WLAN
    - Via GPIB
- Includes documentation and scripting example
- LabVIEW driver sample

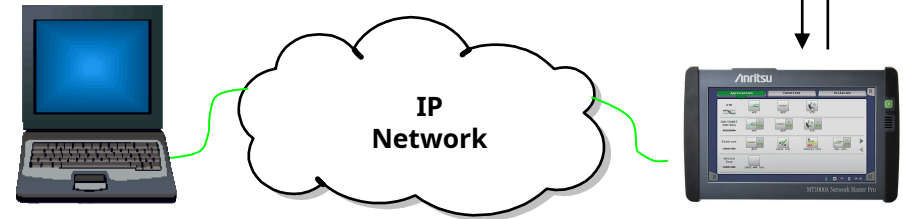

J1667A GPIB-USB Converter available for automated environments based on GPIB.

# Network Master Pro MT1000A

- Remote Control – GUI & Scripting

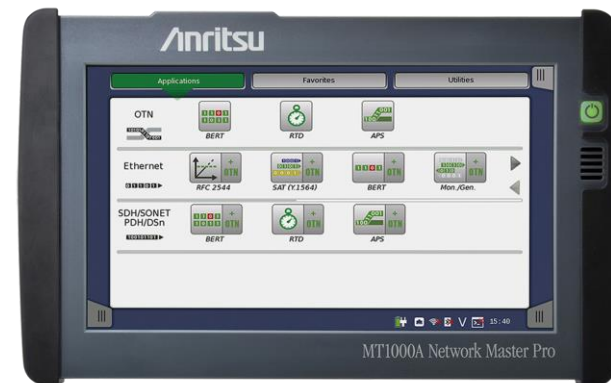

# Remote Control GUI & Scripting Option

- Execution became possible simultaneously about remote GUI (MX100001A) control and SCPI control at each port.
  - Customer can use one facility more effectively by being able to use two kinds of control commands at the same time.

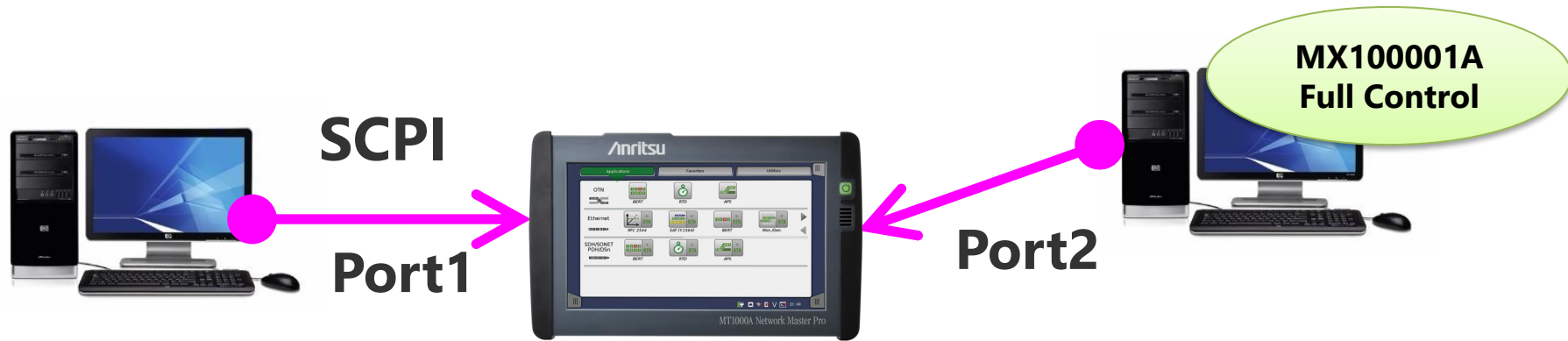

# Remote Control GUI & Scripting Option

- Show who are using the port on the resource monitor screen of MT1000A

## MX100001A Remote Operation Initial window

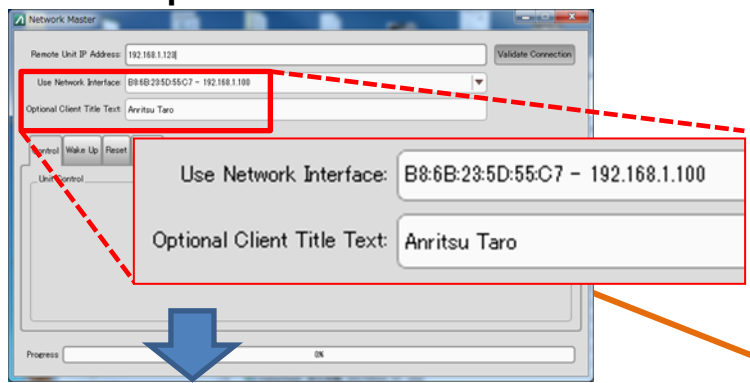

MX100001A window after Application Start

## MT1000A Resource Monitor window

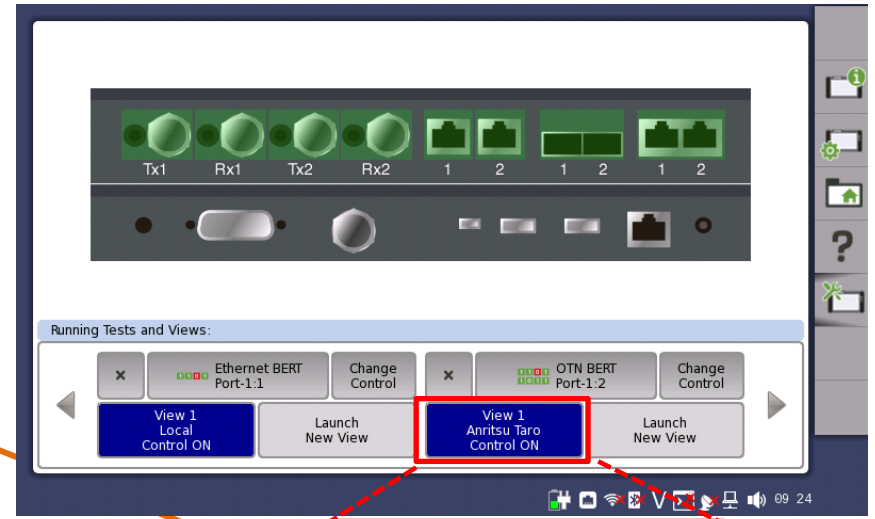

### Useful Point !

To identify who are using the occupied port, it can be allowed to present "Nickname" on the MT1000A GUI.

192.168.1.100

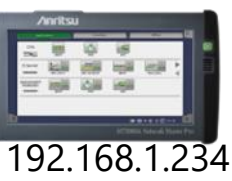
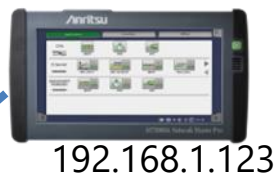

# Remote Control GUI & Scripting Option

If the IP address of MT1000A connected to the network is known, it can be powered-on/off by remote control from the MX100001A (only when connected to AC adapter).

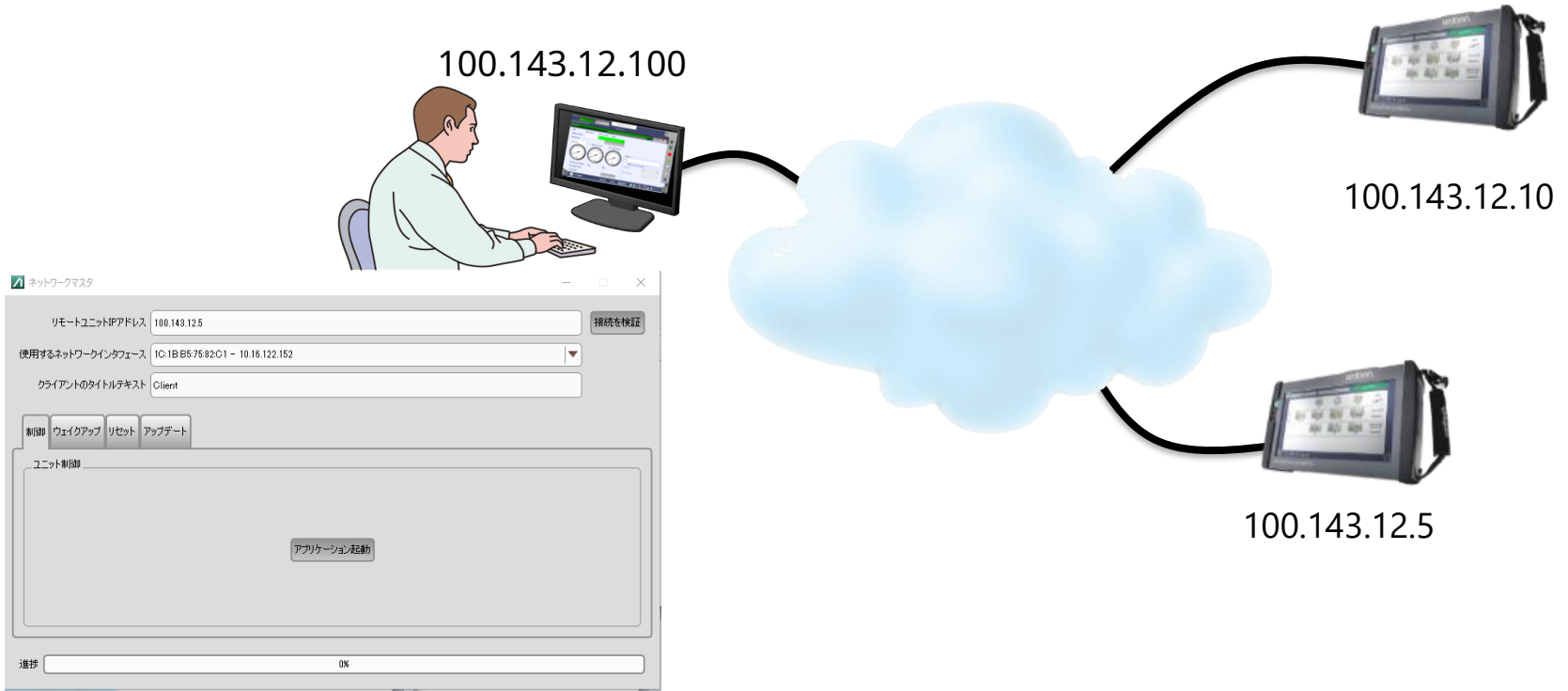



# Network Master Pro MT1000A

- Automation Testing

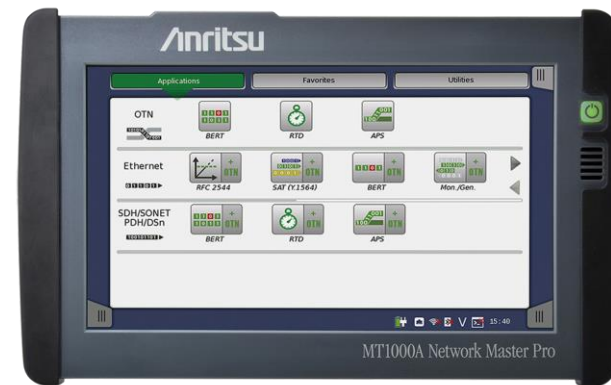

# Automation Testing (1/3)

- Installation and maintenance tests have several challenges.
  - Varying Work Time and Test Results Quality Dependent on Technician's Experience
  - Increasing Risk of Work Errors as Test Items increase
  - Reducing work burn to minimize errors
- Network Master have the One-Button Test Mode by creating a settings file for each manual procedure enables field technicians to run tests and complete pass/fail evaluations with a single click.

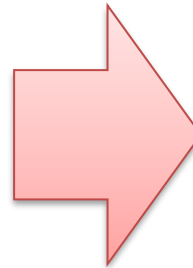

Setting Test Equipment: **Manual**  
 Executing Test: **Manual**  
 Evaluating Results: **Based on data**

Setting Test Equipment: **NA**  
 Executing Test: **NA**  
 Evaluating Results: **NA**  
 → **One-button automation**

# Automation Testing (2/3)

- Anritsu's Automated testing cuts timing time

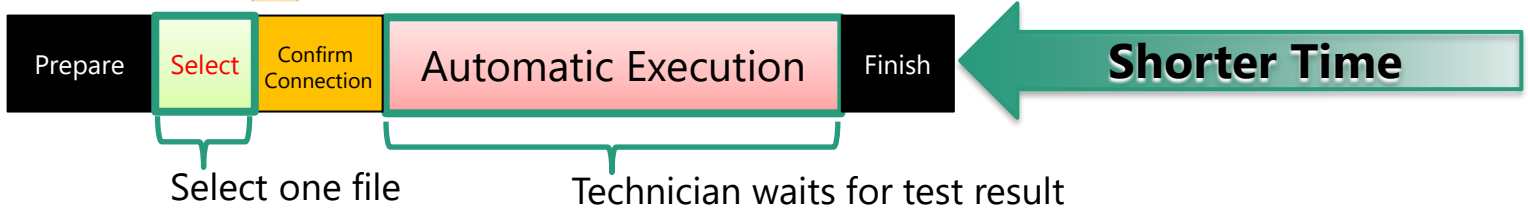
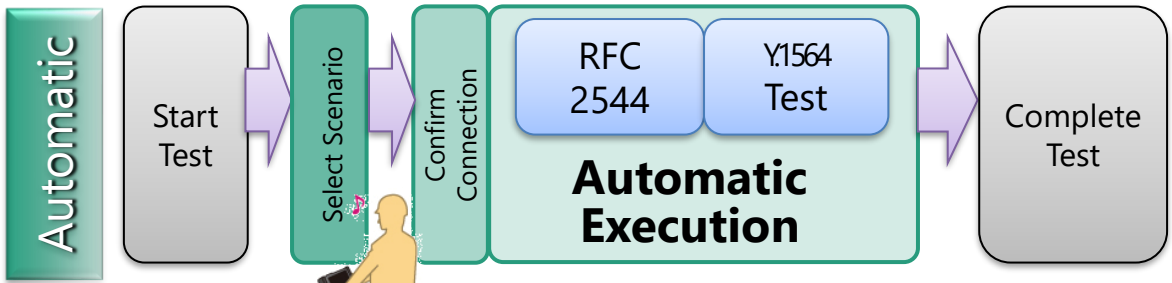
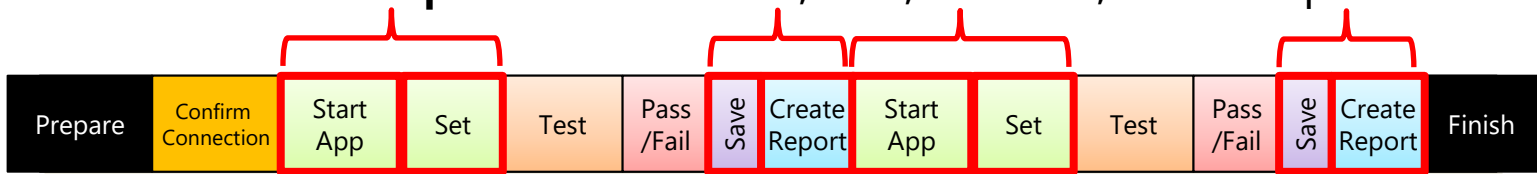
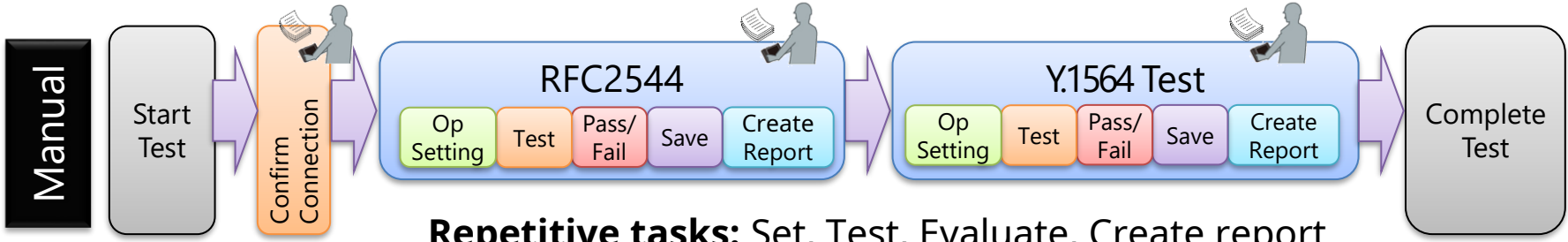

# Automation Testing (3/3)

- Scenario Environment Editing Kit (SEEK) MX100003A
  - Free tool for creating automatic test scenarios for use on the MT1000A
  - Test scenarios are created using the PC SEEK GUI with drag and drop operations

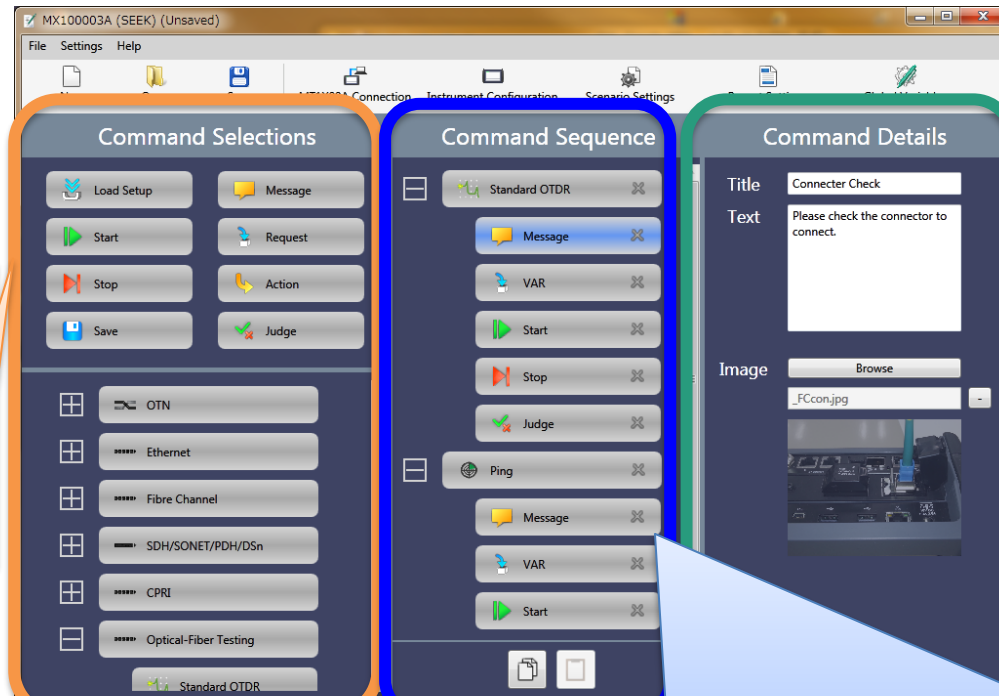

**Command Selection**  
The MT1000A command functions are listed as icons here to create the test scenario using drag and drop operations.

**Command Details**  
Comments, such as cable connection, test notes, etc., can be displayed here. Parameter input is also supported.

**Test Scenario Creation Area**  
The scenario is created here by dragging icons from the command list into a series.

The Anritsu logo is displayed in a bold, green, sans-serif font. Below it, the tagline "Advancing beyond" is written in a smaller, black, sans-serif font. The background features a light green gradient with several curved, parallel lines in shades of green and yellow on the right side.

# Anritsu

Advancing beyond