

Anritsu Advancing beyond

VNA Master™

The Ultimate Handheld Vector Network +
Spectrum Analyzer for Cable, Antenna, and
Signal Analysis Anytime, Anywhere

MS2036C

5 kHz to 6 GHz Vector Network Analyzer
9 kHz to 9 GHz Spectrum Analyzer



Introduction

High Performance Handheld S-Parameters — Meet the MS2036C VNA Master + Spectrum Analyzer, the industry's broadest frequency handheld solution to address cable, antenna, component, and signal analysis needs in the field with frequency coverage from 5 kHz up to 9 GHz. Equally impressive, this broadband measurement tool offers the industry's first 12-term error correction algorithm in a truly handheld, battery-operated, rugged multi-function instrument. Optional Time Domain with Low Pass Step response and Real Impedance graph delivers standard TDR-type display results. Time Domain also includes a standard gating function.

The MS2036C includes a powerful spectrum analyzer that multiplies user convenience by combining spectrum analysis with the VNA into a single measurement powerhouse for the harsh RF and physical environments of field test.

Whether it is for spectrum monitoring, broadcast proofing, interference analysis, RF and microwave measurements, regulatory compliance, or 3G/4G and wireless data network measurements, this VNA/Spectrum Analyzer combination is the ideal instrument for making fast and reliable measurements in the field.

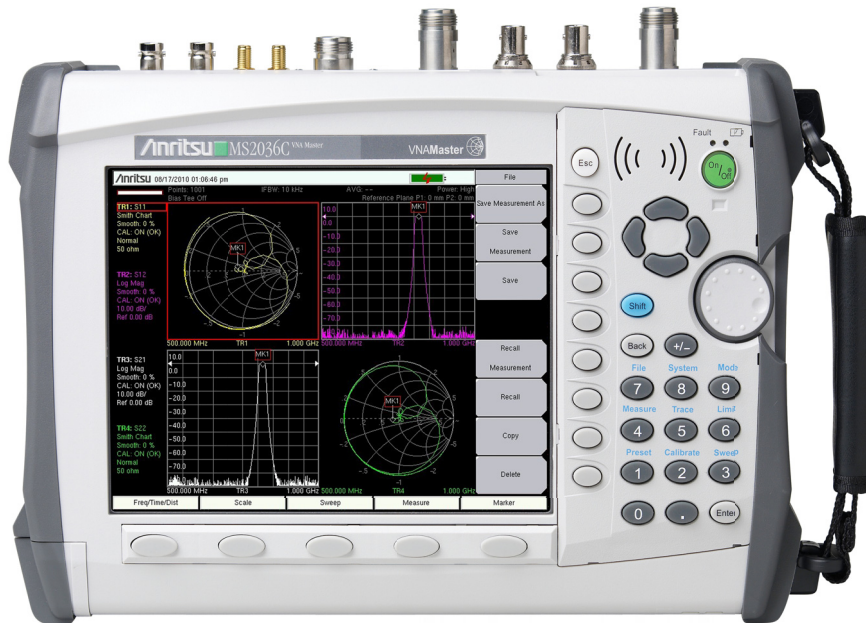

VNA Master™ MS2036C Vector Network Analyzer + Spectrum Analyzer
Size: 211 mm x 315 mm (8.3 in x 12.4 in), Lightweight: 4.8 kg (10.5 lb)

Vector Network Analyzer Performance and Functional Highlights

- Broadband coverage of 5 kHz to up to 6 GHz
- True 2-path, 2-port Vector Network Analyzer
- Ultimate accuracy with 12-term error correction
- High Performance Handheld S-Parameters
- User-defined Quad Display for viewing all 4 S-Parameters
- Arbitrary data points up to 4001
- IF Bandwidth selections of 10 Hz to 100 kHz
- Directivity:
 - > 42 dB up to 6 GHz
 - Supports Reciprocal Through Calibration types (SOLR, SSLR, SSSR)
- Waveguide measurements
- 350 μ s/data point sweep speed
- USB/Ethernet for PC data transfer and control
- Automate repetitive tasks via Ethernet & USB
- PIM Hunting
- Complies with MIL-PRF-28800F Class 2, Certified for use in Explosive Atmosphere per MIL-PRF-28800F and MIL-STD-810G
- Field upgradeable firmware
- Operation to +55 °C: full performance on AC or battery
- Store more than 4000 traces and setups in memory
- Portable: 4.5/4.8 kg (9.9/10.5 lb)
- Time Domain (with gating) option
- Internal Bias Tee option
- Vector Voltmeter option
- High Accuracy Power Meter option
- Differential option (S_{d1d1} , S_{c1c1} , S_{d1c1} , and S_{c1d1})
- Secure Data Operation option for safe use in high security environments
- GPS Receiver option
- Low Pass Stepped Response and Real Impedance graph type provide TDR functionality (standard capability with Time Domain option)
- Multiple display formats including Polar and Real Impedance
- Supports Anritsu USB Power Sensors
- 8.4 in, 800 x 600 high resolution, daylight-viewable TFT color display

Spectrum Analyzer Performance and Functional Highlights

- Broadband coverage of 9 kHz to up to 9 GHz
- Measure: Occupied Bandwidth, Channel Power, ACPR, C/I
- Dynamic Range: > 106 dB in 1 Hz RBW
- DANL: -164 dBm in 1 Hz RBW
- Phase Noise: -106 dBc/Hz @ 10 kHz offset at 1 GHz
- GPS-Enhanced Frequency Accuracy: < \pm 25 ppb with GPS On and locked. GPS-Enhanced Frequency Accuracy is retained after GPS unlock at < 50 ppb for 72 hours, 0 °C to 50 °C
- 1 Hz to 10 MHz Resolution Bandwidth (RBW)
- Traces: Normal, Max Hold, Min Hold, Average, # of Averages
- Detectors: Peak, Negative, Sample, Quasi-peak, and true RMS
- Markers: 6, each with a Delta Marker, or 1 Reference with 6 Deltas
- Limit Lines: up to 40 segments with one-button envelope creation
- Trace Save-on-Event: crossing limit line or sweep complete
- Option to automatically optimize sweep-RBW-VBW trade-off for best possible display
- Interference Analyzer Option: Spectrogram, Signal Strength, RSSI
- Standard Burst Detect: 1000X faster sweep with spans up to 15 MHz. Captures intermittent signals as narrow as 200 μ S every time.
- GPS tagging of stored traces
- Internal Preamplifier standard
- High Accuracy Power Meter Option
- AM/FM/SSB Demodulation (audio only)
- Optional AM/FM/PM Analyzer
- Optional Coverage Mapping
- Optional Channel Scanner

Table of Contents

Definitions 4

VNA Performance Specifications 5

VNA Functional Specifications 6

Corrected System Performance and Uncertainties — High Port Power 7

Distance Domain Specifications 11

Time Domain (Option 2) Specifications 11

Option Comparison Table (Distance Domain and Time Domain) 11

Secure Data Operation (Option 7) 11

Bias Tee (Option 10) 12

Balanced/Differential S-Parameters, 1-Port (Option 77) 12

Vector Voltmeter (Option 15) 12

Spectrum Analyzer Performance Specifications 13

High Accuracy Power Meter (Option 19) 14

Interference Analyzer (Option 25) 15

Channel Scanner (Option 27) 15

Coverage Mapping (Option 431) 16

GPS Receiver (Option 31) 16

AM/FM/PM Signal Analyzer (Option 509) 16

General Specifications 18

Line Sweep Tools™ 19

Master Software Tools 20

Ordering Information 21

Standard Accessories 22

USB Power Sensors 22

Optional Accessories 23

Related Literature, Application Notes, Manuals 33

Definitions

All specifications and characteristics apply to Revision 2 instruments under the following conditions, unless otherwise stated:

| | |
|---------------------|---|
| Warm-Up Time | After 15 minutes of warm-up time in VNA mode, where the instrument is left in the ON state. |
| Temperature Range | Over the 23 °C ± 5 °C temperature range. |
| Reference Signal | When using internal reference signal. |
| Spectrum Analyzer | After 5 minutes of warm-up time, where the instrument is left in the ON state and Sweep Mode set to Performance. |
| Typical Performance | Typical specifications that are not in parenthesis are not tested and not warranted. They are generally representative of characteristic performance. Typical specifications in parenthesis () represent the mean value of measured units and do not include any guard-bands or uncertainties. They are not warranted. |
| Uncertainty | A coverage factor of x1 is applied to the "VNA" or "corrected system" measurement uncertainties to facilitate comparison with other industry handheld analyzers. |
| Calibration Cycle | Calibration is within the recommended 12 month period (residual specifications also require calibration kit calibration cycle adherence.) |

All specifications subject to change without notice. For the most current data sheet, please visit the Anritsu web site: www.anritsu.com



VNA Performance Specifications

Block Diagram

Simplified block diagram of the VNA Master has a 2-port, 2-path architecture that automatically measures four S-parameters with a single connection.

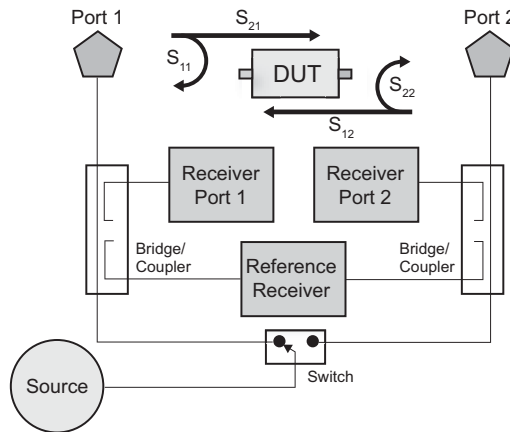

Frequency

| | |
|----------------------|---------------------------------|
| Frequency Range | MS2036C: 5 kHz to 6 GHz |
| Frequency Accuracy | ±1.5 ppm |
| Frequency Resolution | 1 Hz to 375 MHz, 10 Hz to 6 GHz |

Test Port Power

VNA Master supports selection of either High (default) or Low test port power. Changing power after calibration can degrade the calibrated performance.

| Frequency Range | High Port Power (dBm) | Low Port Power (dBm) | (all values typical) |
|------------------|-----------------------|----------------------|----------------------|
| 5 kHz to 3 GHz | +3 | -25 | |
| > 3 GHz to 6 GHz | -3 | -25 | |

Transmission Dynamic Range (difference between test port power and noise floor) using 10 Hz IF Bandwidth and High Port Power

| Frequency Range | Dynamic Range (dB) |
|------------------|--------------------|
| 5 kHz to 2 MHz | 85 dB |
| > 2 MHz to 3 GHz | 100 dB |
| > 3 GHz to 6 GHz | 90 dB |

Sweep Speed

The typical sweep speed in $\mu\text{s}/\text{point}$ for IF Bandwidth of 100 kHz, 1001 data points, and single display is shown for the following frequencies. The three receiver architecture will simultaneously collect S_{21} and S_{11} (or S_{12} and S_{22}) in a single sweep

| Frequency Range | Sweep Speed |
|-----------------|--|
| 5 kHz to 6 GHz | 350 $\mu\text{s}/\text{point}$ typical |

High-Level Noise S_{11} or S_{22} , Short, Power = High, IFBW = 200 Hz, typical

| Frequency Range | Magnitude | Phase |
|-----------------|----------------|-----------|
| 5 kHz to 6 GHz | 0.004 dB (rms) | 0.040 deg |

Noise Floor 10 Hz IFBW

| Frequency | Noise Floor |
|------------------|------------------|
| 5 kHz to 2 MHz | -85 dBm typical |
| > 2 MHz to 3 GHz | -100 dBm typical |
| > 3 GHz to 6 GHz | -96 dBm typical |

Temperature Stability S_{11} or S_{22} , Short, 23 °C ± 5 °C, typical

| Frequency Range | Magnitude | Phase |
|-----------------|-------------|--------------|
| 5 kHz to 10 GHz | 0.018 dB/°C | 0.160 deg/°C |



VNA Functional Specifications

| | |
|-----------------------------------|---|
| Measurement Parameters | S_{11} , S_{21} , S_{22} , S_{12} , (optionally: S_{d1d1} , S_{c1c1} , S_{d1c1} , S_{c1d1}) |
| Number of Traces | Four: TR1, TR2, TR3, TR4 |
| Trace Format | Single, Dual, Tri, Quad, with Trace overlay capabilities |
| Graph Types | Log Magnitude, SWR, Phase, Real, Imaginary, Group Delay, Smith Chart, Inverted Smith Chart (Admittance), Log Mag/2 (1-Port Cable Loss), Linear Polar, Log Polar, Real Impedance, Imaginary Impedance |
| Domains | Frequency Domain, Distance Domain, Time Domain with gating (Time Domain optional) |
| Frequency | Start Frequency, Stop Frequency, Center Frequency, Span |
| Distance | Start Distance, Stop Distance |
| Time | Start Time, Stop Time |
| Frequency Sweep Type: Linear | Single Sweep, Continuous |
| Data Points | 2 to 4001 (arbitrary setting); data points can be reduced without recalibration. |
| Limit Lines | Upper, Lower, 10-segmented Upper, 10-segmented Lower |
| Test Limits | Pass/Fail for Upper, Pass/Fail for Lower, Limit Audible Alarm |
| Data Averaging | Sweep-by-sweep |
| Smoothing | 0 % to 20 % |
| IF Bandwidth (Hz) | 10, 20, 50, 100, 200, 500, 1k, 2k, 5k, 10k, 20k, 50k, 100k |
| Reference Plane | The reference planes of a calibration (or other normalization) can be changed by entering a line length. Assumes no loss, flat magnitude, linear phase, and constant impedance. |
| Auto Reference Plane Extension | Instead of manually entering a line length, this feature automatically adjusts phase shift from the current calibration (or other normalization) to compensate for external cables (or test fixtures). Assumes no loss, flat magnitude, linear phase, and constant impedance. |
| Group Delay Aperture | Defined as the frequency span over which the phase change is computed at a given frequency point. The aperture can be changed without recalibration. The minimum aperture is the frequency range divided by the number of points in calibration and can be increased to 20 % of the frequency range. |
| Group Delay Range | < 180° of phase change within the aperture |
| Trace Memory | A separate memory for each trace can be used to store measurement data for later display. The trace data can be saved and recalled. |
| Trace Math | Complex trace math operations of subtraction, addition, multiplication, or division are provided. |
| Number of Markers | 12, arbitrary assignments to any trace |
| Marker Types | Reference, Delta |
| Marker Readout Styles | Log Mag, Cable Loss (Log Mag / 2), Log Mag and Phase, Phase, Real and Imaginary, SWR, Impedance, Admittance, Normalized Impedance, Normalized Admittance, Polar Impedance, and Group Delay, Linear Mag, Linear Mag and Phase |
| Marker Search | Peak Search, Valley Search, Find Marker Value |
| Correction Models | Full 2-Port, Full S_{11} , Full S_{22} , Full S_{11} & S_{22} , Response S_{21} , Response S_{12} , Response S_{21} & S_{12} , Response S_{11} , Response S_{22} , Response S_{11} & S_{22} , One- Path Two-Port (S_{11}, S_{21}), One-Path Two-Port (S_{22}, S_{12}) |
| Calibration Types | Flex, Standard |
| Calibration Methods | Short-Open-Load-Through (SOLT), Offset-Short (SSLT), and Triple-Offset-Short (SSST), Short-Open-Load-Reciprocal (SOLR), Double-Offset-Short-Load-Reciprocal (SSLR), Triple-Offset-Short-Reciprocal (SSSR) |
| Calibration Standard Coefficients | Coax: N-Connector, K-Connector, 7/16, TNC, SMA, and four User Defined coax types Waveguide: WG11A, WG12, WG13, WG14, WG15, WG16, WG17, WG18, WG20, and four User Defined rectangular waveguide types |
| Cal Correction Toggle | On/Off |
| Interpolation | On/Off |
| Dispersion Compensation | Waveguide correction that improves accuracy of distance-to-fault data by compensating for different wavelengths propagating at different speeds. |
| Impedance Conversion | Support for 50 Ω and 75 Ω are provided. |
| Units | Meters, Feet |
| Bias Tee Settings | Internal, External, Off |
| Timebase Reference | Internal, External |
| File Storage Types | Measurement (.mna), Setup (.stp, with or without CAL), S2P (Real/Imag), S2P (Lin Mag/Phase), S2P (Log Mag/Phase), Text (VNA Only), CSV (VNA Only), JPEG |
| Ethernet Configuration | DHCP or Manual (Static) IP configuration, 10/100 Base-T, RJ45 jack |
| Languages | English, French, German, Spanish, Chinese, Japanese, Korean, Italian, Russian, Portuguese (Português) |

Corrected System Performance and Uncertainties — High Port Power

Measurement Accuracy¹ (OSLN50A-18 or TOSLN50A-18)

| Frequency Range | Directivity (dB) | Source Match (dB) | Load Match (dB) | Reflection Tracking (dB) | Transmission Tracking (dB) |
|-------------------|------------------|-------------------|-----------------|--------------------------|----------------------------|
| 5 kHz to 20 MHz | ≥ 42 | ≥ 30 | ≥ 42 | ± 0.02 | ± 0.01 |
| > 20 MHz to 3 GHz | ≥ 42 | ≥ 30 | ≥ 42 | ± 0.07 | ± 0.01 |
| > 3 GHz to 6 GHz | ≥ 42 | ≥ 30 | ≥ 42 | ± 0.05 | ± 0.02 |

Transmission Uncertainty (S_{21} , S_{12})

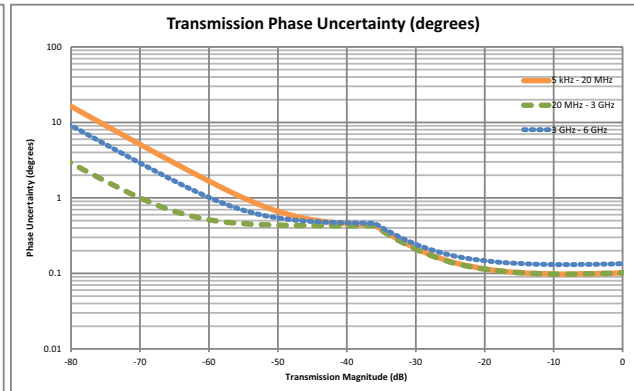
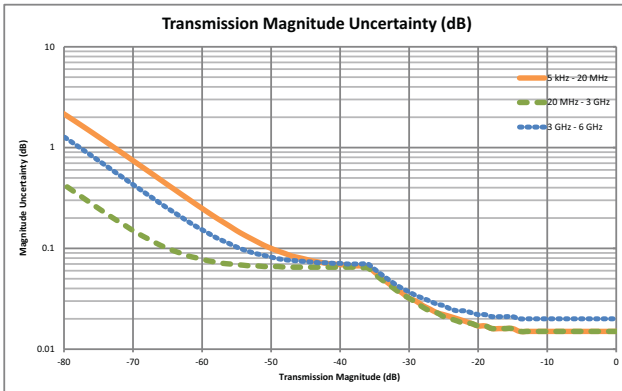

Reflection Uncertainty (S_{11} , S_{22})

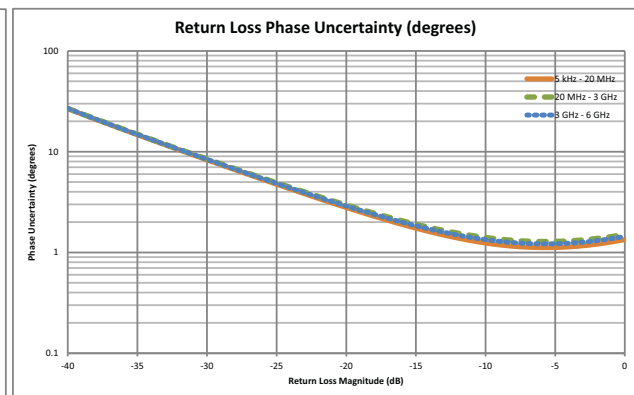
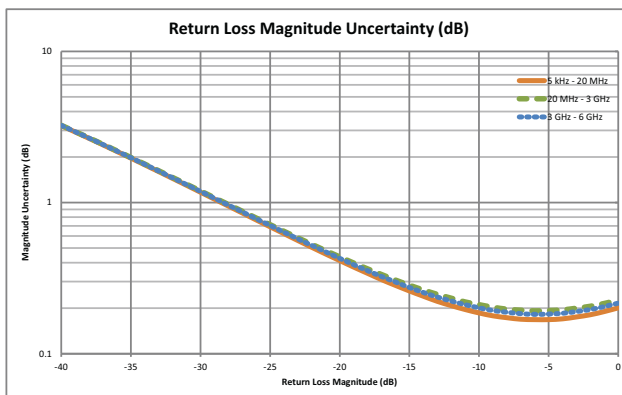

1.Full 2-Port calibration, Default Power, 10 Hz IFBW, No averaging, 10 minute warm-up. OSLN50A-18 or TOSLN50A-18 calibration kit.
 Load match specification applicable directly at corrected port only. De-rate by approximately 8 dB if using a 3670 series test port cable.
 Reflection and Transmission Tracking are typical.

Corrected System Performance and Uncertainties — High Port Power (continued)

Measurement Accuracy¹ (OSLNF50A-18, or TOSLNF50A-18)

| Frequency Range | Directivity (dB) | Source Match (dB) | Load Match (dB) | Reflection Tracking (dB) | Transmission Tracking (dB) |
|-------------------|------------------|-------------------|-----------------|--------------------------|----------------------------|
| 5 kHz to 20 MHz | ≥ 42 | ≥ 30 | ≥ 42 | ± 0.02 | ± 0.01 |
| > 20 MHz to 3 GHz | ≥ 42 | ≥ 30 | ≥ 42 | ± 0.07 | ± 0.01 |
| > 3 GHz to 6 GHz | ≥ 42 | ≥ 30 | ≥ 42 | ± 0.05 | ± 0.02 |

Transmission Uncertainty (S_{21} , S_{12})

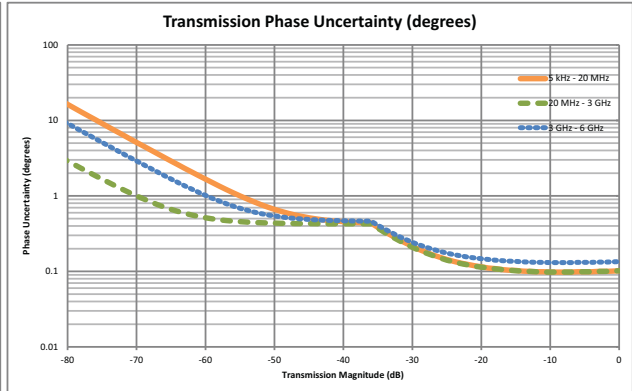
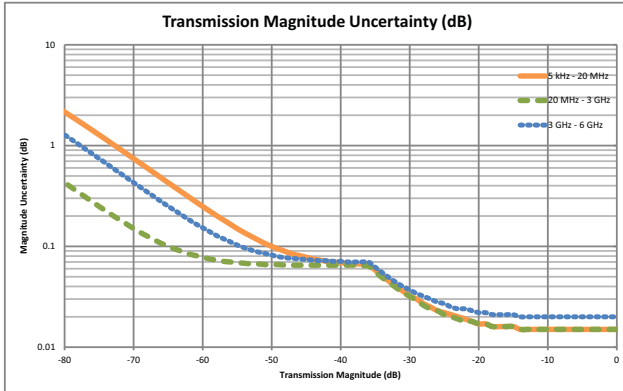

Reflection Uncertainty (S_{11} , S_{22})

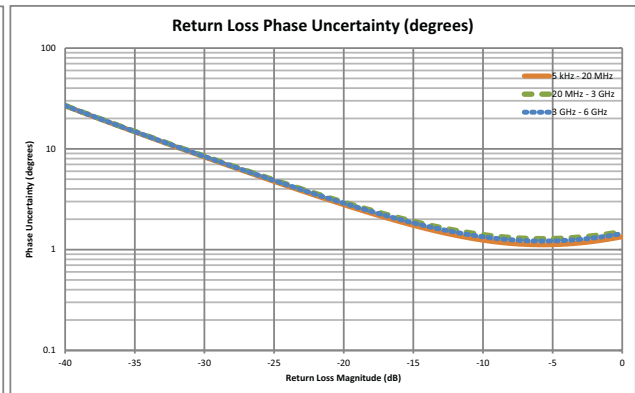
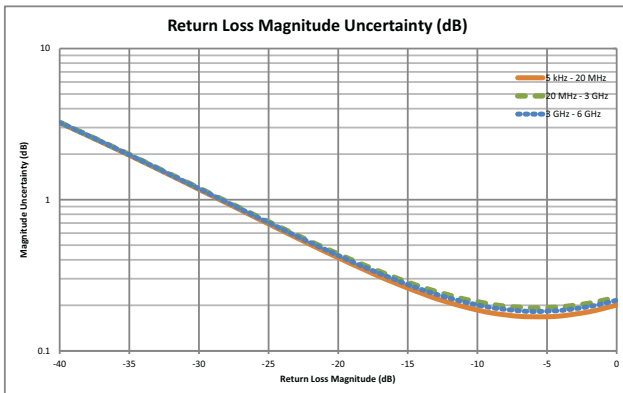

1. Full 2-Port calibration, Default Power, 10 Hz IFBW, No averaging, 10 minute warm-up. OSLNF50A-18 or TOSLNF50A-18 calibration kit. Load match specification applicable directly at corrected port only. De-rate by approximately 8 dB if using a 3670 series test port cable. Reflection and Transmission Tracking are typical.

Corrected System Performance and Uncertainties — High Port Power (continued)

Measurement Accuracy¹ (TOSLK50A-20 or TOSLK50A-40)

| Frequency Range | Directivity (dB) | Source Match (dB) | Load Match (dB) | Reflection Tracking (dB) | Transmission Tracking (dB) |
|-------------------|------------------|-------------------|-----------------|--------------------------|----------------------------|
| 5 kHz to 20 MHz | ≥ 42 | ≥ 33 | ≥ 42 | ± 0.02 | ± 0.01 |
| > 20 MHz to 3 GHz | ≥ 42 | ≥ 33 | ≥ 42 | ± 0.07 | ± 0.01 |
| > 3 GHz to 6 GHz | ≥ 42 | ≥ 33 | ≥ 42 | ± 0.05 | ± 0.02 |

Transmission Uncertainty (S_{21} , S_{12})

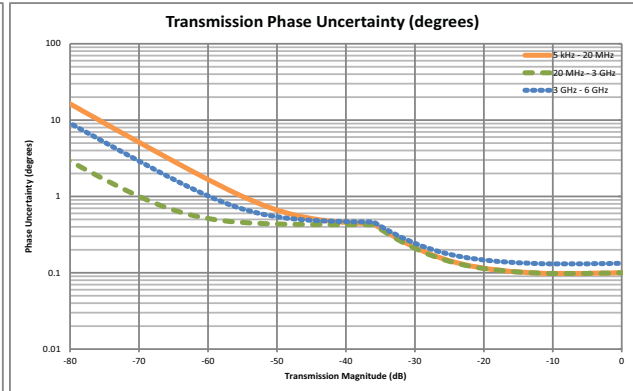
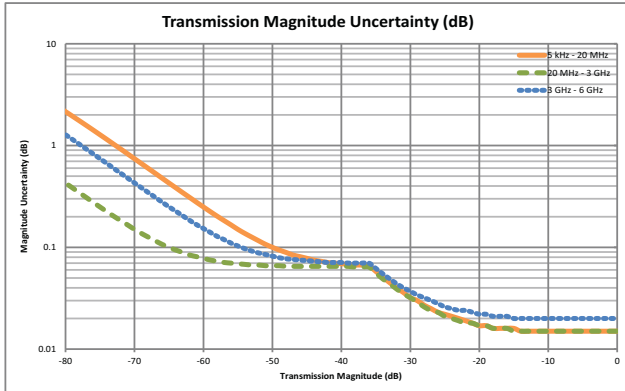

Reflection Uncertainty (S_{11} , S_{22})

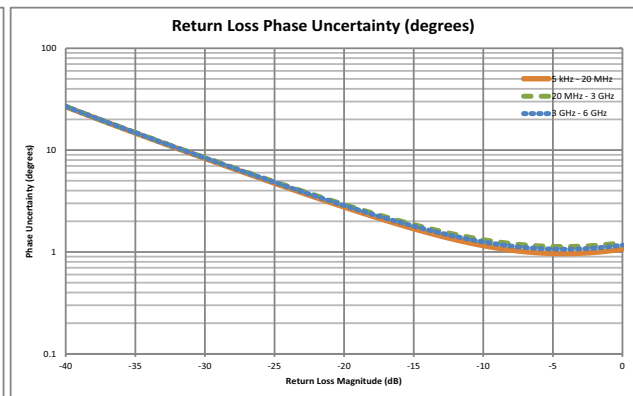
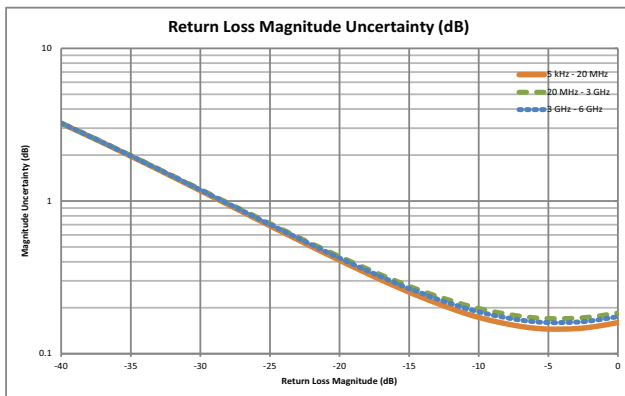

1. Full 2-Port calibration, Default Power, 10 Hz IFBW, No averaging, 10 minute warm-up. TOSLK50A-20 or TOSLK50A-40 calibration kit. Load match specification applicable directly at corrected port only. De-rate by approximately 8 dB if using a 3670 series test port cable. Reflection and Transmission Tracking are typical.

Corrected System Performance and Uncertainties — High Port Power (continued)

Measurement Accuracy¹ (TOSLK50A-20, or TOSLK50A-40)

| Frequency Range | Directivity (dB) | Source Match (dB) | Load Match (dB) | Reflection Tracking (dB) | Transmission Tracking (dB) |
|-------------------|------------------|-------------------|-----------------|--------------------------|----------------------------|
| 5 kHz to 20 MHz | ≥ 42 | ≥ 33 | ≥ 42 | ± 0.02 | ± 0.01 |
| > 20 MHz to 3 GHz | ≥ 42 | ≥ 33 | ≥ 42 | ± 0.07 | ± 0.01 |
| > 3 GHz to 6 GHz | ≥ 42 | ≥ 33 | ≥ 42 | ± 0.05 | ± 0.02 |

Transmission Uncertainty (S_{21} , S_{12})

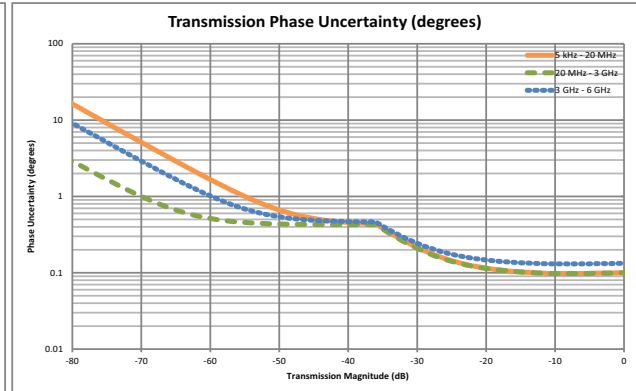
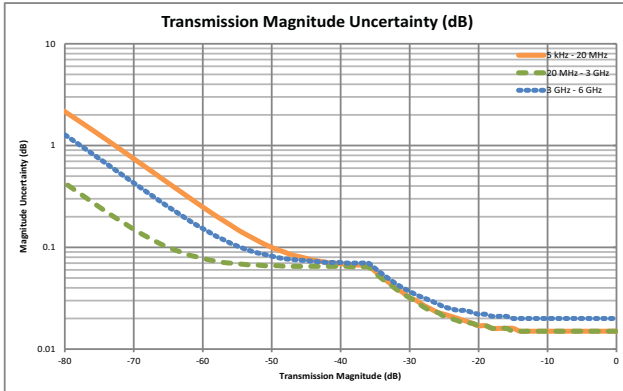

Reflection Uncertainty (S_{11} , S_{22})

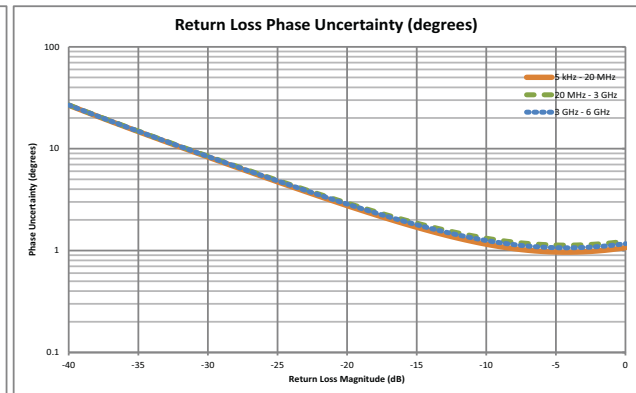
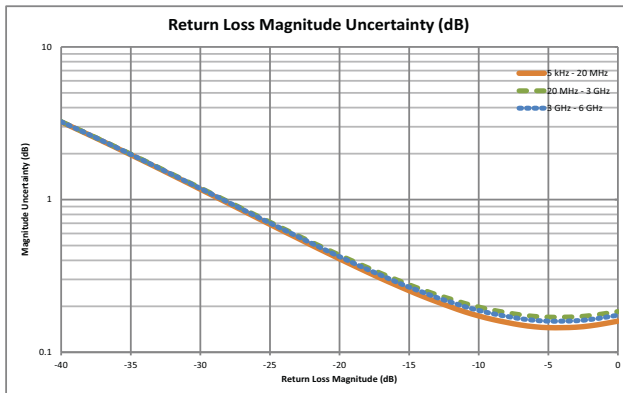

1. Full 2-Port calibration, Default Power, 10 Hz IFBW, No averaging, 10 minute warm-up. TOSLK50A-20 or TOSLK50A-40 calibration kit. Load match specification applicable directly at corrected port only. De-rate by approximately 8 dB if using a 3670 series test port cable. Reflection and Transmission Tracking are typical.



Distance Domain Specifications (formerly Option 501, now standard with firmware revision v1.16 or higher)

Distance Domain Analysis is a powerful field test tool to analyze cables for faults, including minor discontinuities that may occur due to a loose connection, corrosion, or other aging effects. By using Frequency Domain Reflectometry (FDR), the VNA Master exploits a user-specified band of full power operational frequencies (instead of DC pulses from TDR approaches) to more precisely identify cable discontinuities. The VNA Master converts S-parameters from frequency domain into distance domain on the horizontal display axis, using a mathematical computation called Inverse Fourier Transform. Connect a reflection at the opposite end of the cable, and the discontinuities appear versus distance to reveal any potential maintenance issues. When access to both ends of the cable is convenient, a similar distance domain analysis is available on transmission measurements.

Distance Domain will improve your productivity with displays of the cable in terms of discontinuities versus distance. This readout can then be compared against previous measurements (from stored data) to determine whether any degradations have occurred since installation (or the last maintenance activity). More importantly, you will know precisely where to go to fix the problem and so minimize or prevent downtime of the system.

| | |
|---------------------------|--|
| Round-Trip (reflection) | |
| Fault Resolution (meters) | $(0.5 \times c \times Vp) / \Delta F$; (c is speed of light = 299,792,458 m/s, ΔF is F2 - F1 in Hz) |
| One-Way (transmission) | |
| Fault Resolution (meters) | $(c \times Vp) / \Delta F$; (c is speed of light = 299,792,458 m/s, ΔF is F2 - F1 in Hz) |
| Horizontal Range (meters) | 0 to (data points - 1) x Fault Resolution to a maximum of 3000 m (9843 ft) |
| Windowing | Rectangular, Nominal Side Lobe (NSL), Low Side Lobe (LSL), and Minimum Side Lobe (MSL) |



Time Domain (Option 2) Specifications (includes Distance Domain)

The VNA Master can display the S-parameter measurements in the time or distance domain using lowpass or bandpass processing analysis modes. The broadband frequency coverage coupled with 4001 data points means you can measure discontinuities both near and far with unprecedented clarity for a handheld tool.

With this option, you can simultaneously view S-parameters in frequency, time, and distance domain to quickly identify faults in the field. Advanced features available with this option include step response, phasor impulse, gating, and frequency gated in time. The option includes computational routines that further enhance the Distance Domain results by compensating for cable loss, relative velocity of propagation, and dispersion compensation in waveguide. See the Distance Domain Specifications above.



Option Comparison Table (Distance Domain and Time Domain)

| Measurement | Distance Domain (formerly Option 501) | Option 2 Time Domain |
|-----------------------------------|--|-------------------------|
| Distance-to-Fault | X | X |
| Distance Domain display | X | X |
| Windowing | X | X |
| Distance of Waveguide | | X |
| Time Domain display | | X |
| One Way vs. Round Trip Reflection | | X |
| Phasor Impulse | | X |
| Impulse Response | | X |
| Step Response | | X |
| Low Pass vs. Bandpass | | X |
| Frequency Gated by Time | | X |
| Frequency Gated by Distance | | X |



Secure Data Operation (Option 7)

For highly secure data handling requirements, this software option prevents the storing of measurement setup or data information onto any internal file storage location. Instead, setup and measurement information is stored ONLY to the external USB memory location. A simple factory preset prepares the VNA Master for transportation while the USB memory remains behind in the secure environment. The VNA Master cannot be switched between secure and non-secure operation by the user once configured for secure data operation. With this option enabled, the user can also choose to blank the frequency values displayed on the screen.



Bias Tee (Option 10)

For tower mounted amplifier tests, the MS2036C series with optional internal bias tees can supply both DC and RF signals on the center conductor of the cable during measurements. For frequency sweeps in excess of 2 MHz, the VNA Master can supply internal voltage control from +12 V to +32 V in 0.1 V steps up to 450 mA. To extend battery life, an external power supply can substitute for the internal supply by using the included external bias ports. Both test ports can be configured to supply voltage via this integrated bias tees option. Bias can be directed to VNA Port 1 or Port 2.

Bias Tee Specifications The VNA Master offers optional integrated bias tee for supplying DC plus RF0 to the DUT as shown in the simplified block diagram. Connectivity is also provided for external supply (instead of internal) to preserve battery consumption.

| | |
|--------------------------|--------------------------------------|
| Frequency Range | 2 MHz to 6 GHz (MS2036C) |
| Internal Voltage/Current | +12 V to +32 V at 450 mA steady rate |
| Internal Resolution | 0.1 V |
| External Voltage/Current | ± 50 V at 500 mA steady rate |
| Bias Tee Selections | Internal, External, Off |

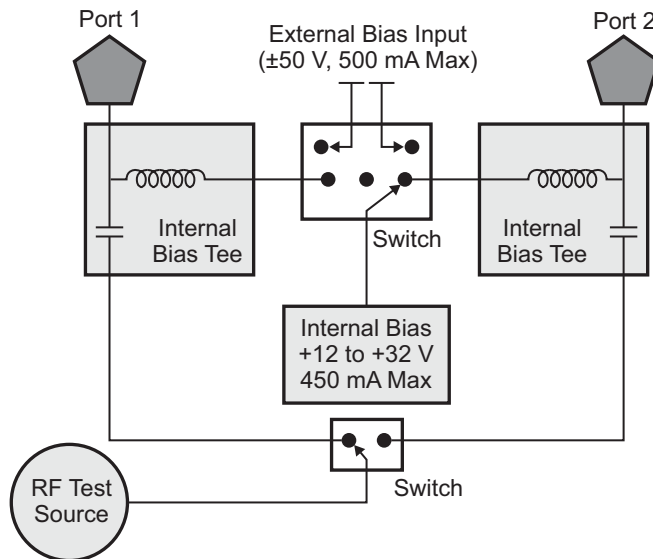

Balanced/Differential S-Parameters, 1-Port (Option 77)

As an alternative to a sampling oscilloscope, verifying the performance and identifying discontinuities in high-data-rate differential cables is now possible with the VNA Master. After a full two-port calibration, connect your differential cable directly to the two test ports and reveal the S_{d1d1} performance, which is essentially differential return loss, or any of the other differential S-Parameters, S_{c1c1} , S_{d1c1} , or S_{c1d1} . With optional time domain, you can convert frequency sweeps to distance. This capability is especially valuable for applications in high data rate cables where balanced data formats are used to isolate noise and interference.



Vector Voltmeter (Option 15)

A phased array system relies on phase matched cables for nominal performance. For this class of application, the VNA Master offers this special software mode to simplify phase matching cables at a single frequency. The similarity between the popular vector voltmeter and this software mode ensures minimal training is required to phase match cables. Operation is as simple as configuring the display for absolute or relative measurements. The easy-to-read large fonts show either reflection or transmission measurements using impedance, magnitude, or VSWR readouts. For instrument landing system (ILS) or VHF Omni-directional Range (VOR) applications, a table view improves operator efficiency when phase matching up to twelve cables. The MS2036C solution is superior because the signal source is included internally, precluding the need for an external signal generator.

VVM Specifications

| | |
|---------------------|--|
| CW Frequency Range | 5 kHz to 6 GHz (MS2036C) |
| Measurement Display | CW, Table (Twelve Entries, Plus Reference) |
| Measurement Types | Return Loss, Insertion |
| Measurement Format | dB/VSWR/Impedance |



Spectrum Analyzer Performance Specifications

Measurements

| | |
|--------------------|---|
| Smart Measurements | Field Strength (dBm/m ² , dBV/m, dBmV/m, dBμV/m, V/m, Watt/m ² , dBW/m ² , A/m, dBA/m, or Watt/cm ²) Occupied Bandwidth (measures 99 % to 1 % power channel of a signal, or N dB from center of signal) Channel Power (measures the total power in a specified bandwidth) ACPR (Adjacent Channel Power Ratio) Emission Mask (recall limit lines as emission mask) Spurious Emissions (measures up to 32 segments with independent setups and limits) C/I (Carrier-to-Interference ratio) AM/FM/SSB Demodulation (AM, wide/narrow FM, upper/lower SSB (audio only)) PIM Hunting |
|--------------------|---|

Setup Parameters

| | |
|-----------|---|
| Frequency | Center/Start/Stop, Span, Freq Step, Freq Offset, Signal Standard, Channel #, Channel Increment |
| Amplitude | Reference Level (RL), Scale, Attenuation Auto/Level, RL Offset, Units (dBm, dBV, dBmV, dBμV, Volt, Watt, dBW, A, dBA), Pre-Amp On/Off, Detection (Peak, RMS/Avg, Negative Peak, Sample, Quasi-Peak) |
| Span | Span, Span Up/Down (1-2-5), Full Span, Zero Span, Last Span |
| Bandwidth | RBW, Auto RBW, VBW, Auto VBW, VBW/Avg Type (Linear, Log), RBW/VBW Ratio, Span/RBW Ratio |
| Impedance | 50 Ω, 75 Ω; external pad required for 75 Ω operation |

Sweep Functions

| | |
|--------------------|--|
| Sweep | Single/Continuous, Sweep Time |
| Sweep Mode | Fast (up to 100x faster than Performance), Performance, No FFT, Burst Detect (1000x Fast in 15 MHz span) |
| Triggers | Free Run, External, Video, IF Power, Force Trigger Once |
| Trigger Parameters | Delay, Level, Slope, Hysteresis, Holdoff (availability varies with trigger) |

Trace Functions

| | |
|--------------------|--|
| Traces | Up to three Traces (A, B, C), View/Blank, Write/Hold, Trace A/B/C Operations |
| Trace A Operations | Normal, Max Hold, Min Hold, Average, # of Averages, (always the live trace) |
| Trace B Operations | A → B, B ← → C, Max Hold, Min Hold |
| Trace C Operations | A → C, B ← → C, Max Hold, Min Hold, A - B → C, B - A → C, Relative Reference (dB), Scale |

Marker Functions

| | |
|----------------------|---|
| Markers | Markers 1-6 each with a Delta Marker, or Marker 1 Reference with Six Delta Markers, Marker Table (On/Off/Large), All Markers Off |
| Marker Types | Style (Fixed/Tracking), Noise Marker, Frequency Counter Marker |
| Marker Auto-Position | Peak Search, Next Peak (Right/Left), Peak Threshold %, Set Marker to Channel, Marker Frequency to Center, Delta Marker to Span, Marker to Reference Level |
| Marker Table | 1-6 markers frequency and amplitude, plus delta markers frequency offset and amplitude |

Limit Line Functions

| | |
|---------------------|--|
| Available Spans | > 0 Hz |
| Limit Lines | Upper/Lower, On/Off, Edit, Move, Envelope, Advanced, Limit Alarm, Default Limit |
| Limit Line Edit | Frequency, Amplitude, Add Point, Add Vertical, Delete Point, Next Point Left/Right |
| Limit Line Move | To Current Marker Frequency, By dB or Hz, To Marker 1, Offset from Marker 1 |
| Limit Line Envelope | Create Envelope, Update Amplitude, Number of Points (2-41), Offset, Shape Square/Slope |
| Limit Line Advanced | Type (Absolute/Relative), Mirror, Save/Recall |
| Save on Event | When Limit Crossed |

Frequency

| | |
|------------------------------------|---|
| Frequency Range | (usable to 0 Hz) |
| MS2036C | 9 kHz to 9 GHz |
| Tuning Resolution | 1 Hz |
| Frequency Reference | Aging: ± 1.0 × 10 ⁻⁶ per year for 10 years Accuracy: ± 0.3 × 10 ⁻⁶ (25 °C ± 25 °C) plus aging (see Option 31 for improved frequency reference accuracy) |
| External Frequency Reference (MHz) | 1, 1.2288, 1.544, 2.048, 2.4576, 4.8, 4.9152, 5, 9.8304, 10, 13, 19.6608 (auto-sensing) |
| Sweep Time | 7 μs to 3600 s in zero span |
| Sweep Time Accuracy | ± 2 % in zero span |

Bandwidth

| | |
|-------------------------------|---|
| Resolution Bandwidth (RBW) | 1 Hz to 10 MHz in 1-3 sequence ± 10 % (-3 dB bandwidth) |
| Video Bandwidth (VBW) | 1 Hz to 10 MHz in 1-3 sequence (-3 dB bandwidth) |
| RBW with Quasi-Peak Detection | 200 Hz, 9 kHz, 120 kHz (-6 dB bandwidth) |
| VBW with Quasi-Peak Detection | Auto VBW is On, RBW/VBW = 1 |
| VBW/Average Type | Linear/Log |



Spectrum Analyzer Performance Specification (continued)

Spectral Purity – SSB Phase Noise

| Offset from 1 GHz | Maximum | Typical |
|-------------------|-------------|-------------|
| 10 kHz | -102 dBc/Hz | -106 dBc/Hz |
| 100 kHz | -106 dBc/Hz | -110 dBc/Hz |
| 1 MHz | -111 dBc/Hz | -116 dBc/Hz |
| 10 MHz | -123 dBc/Hz | -129 dBc/Hz |

Amplitude Ranges

| | |
|--------------------------|--|
| Dynamic Range | >106 dB minimum at 2.4 GHz, 2/3 (TOI-DANL) in 1 Hz RBW |
| Measurement Range | DANL to +30 dBm |
| Display Range | 1 to 15 dB/div in 1 dB steps, ten divisions displayed |
| Reference Level Range | -150 dBm to +30 dBm |
| Attenuator Resolution | 0 to 65 dB, 5.0 dB steps |
| Reference Level Offset | 99.9 dB External Loss to 99.9 dB External Gain |
| Amplitude Units | Log Scale Modes: dBW, dBm, dBμW, dBV, dBmV, dBμV, dBA, dBmA, dBμA Linear Scale Modes: fV, nV, μV, mV, V, fW, pW, nW, μW, mW, W, pA, nA, μA, mA, A |
| Maximum Continuous Input | +30 dBm Peak typical, ± 50 VDC (≥ 10 dB Attenuation) +23 dBm Peak typical, ± 50 VDC (< 10 dB Attenuation) +13 dBm Peak typical, ± 50 VDC (Preamp = On) |

Amplitude Accuracy (excluding effects of VSWR, noise, and spurs)

| | 20 °C to 30 °C | | -10 °C to 55 °C | |
|-------------------------------|---------------------------|---------|---------------------------|---------|
| | (after 30 minute warm-up) | | (after 60 minute warm-up) | |
| | Maximum | Typical | Maximum | Typical |
| 9 kHz to 100 kHz ^a | ±2.3 dB | ±0.5 dB | ±2.3 dB | ±0.5 dB |
| > 100 kHz to 13 GHz | ±1.3 dB | ±0.5 dB | ±2.3 dB | ±0.5 dB |

a.Values below 100 kHz are with the preamplifier turned off.

Displayed Average Noise Level (DANL) (RMS Detection, VBW/Avg Type = Log, Ref Level = -20 dBm for Preamp Off and -50 dBm for Preamp On, Auto Attenuation, Performance Sweep Mode)

| | Preamp = Off | | Preamp = On | |
|------------------|--------------|----------|-------------|----------|
| | Maximum | Typical | Maximum | Typical |
| 10 MHz to 4 GHz | -145 dBm | -148 dBm | -161 dBm | -164 dBm |
| > 4 GHz to 9 GHz | -142 dBm | -145 dBm | -159 dBm | -162 dBm |

Spurs (0 dB input attenuation)

| Residual Spurs (RF input terminated) < 13 GHz | Preamp = Off | | Preamp = On | |
|--|--------------|----------------------|-------------|-----------------|
| | Maximum | Typical | Maximum | Typical |
| Input-Related Spurious (-30 dBm input) | -90 dBm | -60 dBc ^a | -100 dBm | -70 dBc typical |

a.Instrument centered on single signal, span < 1.7 GHz

Third-Order Intercept (TOI) (-20 dBm tones 100 kHz apart, 0 dB Attenuation Preamp OFF, Reference Level -20 dBm)

| | |
|------------------|-----------------|
| 2.4 GHz | +14 dBm minimum |
| 50 MHz to 20 GHz | +20 dBm typical |

P1dB

| | |
|-----------------|-----------------|
| < 4 GHz | +5 dBm nominal |
| 4 GHz to 20 GHz | +12 dBm nominal |

Second Harmonic Distortion (0 dB input attenuation, -30 dBm input)

| | |
|---------|-----------------|
| 50 MHz | -54 dBc maximum |
| < 4 GHz | -60 dBc typical |
| ≥ 4 GHz | -75 dBc typical |

VSWR (≥ 10 dB input attenuation)

| | |
|----------|---------------|
| ≤ 20 GHz | 1.5:1 typical |
|----------|---------------|



High Accuracy Power Meter (Option 19) (Requires external USB power sensor, sold separately)

| | |
|-----------|--|
| Amplitude | Maximum, Minimum, Offset, Relative On/Off, Units, Auto Scale |
| Average | # of Running Averages, Max Hold |
| Zero/Cal | Zero On/Off, Cal Factor (Center Frequency, Signal Standard) |
| Limits | Limit On/Off, Limit Upper/Lower |

Technical Data

VNA Master

| | | | | | |
|--|--------------------------------------|---------------------------------------|--|---|---|
| Power Sensor Model | MA24105A | MA24106A | MA24108A/18A/26A | MA24208A/18A | MA24330A/40A/50A |
| Description | Inline High Power Sensor | High Accuracy RF Power Sensor | Microwave USB Power Sensor | Microwave Universal USB Power Sensor | Microwave CW USB Power Sensor |
| Frequency Range | 350 MHz to 4 GHz | 50 MHz to 6 GHz | 10 MHz to 8/18/26 GHz | 10 MHz to 8/18 GHz | 10 MHz to 33/40/50 GHz |
| Connector | Type N(f), 50 Ω | Type N(m), 50 Ω | Type N(m), 50 Ω (8/18 GHz) Type K(m), 50 Ω (26 GHz) | Type N(m), 50 Ω | Type K(m), 50 Ω (33/40 GHz) Type V(m), 50 Ω (50 GHz) |
| Dynamic Range | +3 dBm to +51.76 dBm (2 mW to 150 W) | -40 dBm to +23 dBm (0.1 μW to 200 mW) | -40 dBm to +20 dBm (0.1 μW to 100 mW) | -60 dBm to +20 dBm (1 nW to 100 mW) | -70 dBm to +20 dBm (0.1 nW to 100 mW) |
| Measurand | True-RMS | True-RMS | True-RMS, Slot Power, Burst Average Power | True-RMS, Slot Power, Burst Average Power | Average Power |
| Measurement Uncertainty | ± 0.17 dB ^a | ± 0.16 dB ^b | ± 0.18 dB ^c | ± 0.17 dB ^d | ± 0.17 dB ^e |
| Data sheet (for complete specifications) | 11410-00621 | 11410-00424 | 11410-00504 | 11410-00841 | 11410-00906 |

- Notes:
- Expanded uncertainty with K=2 for power measurements of a CW signal greater than +20 dBm with a matched load. Measurement results referenced to the input side of the sensor.
 - Total RSS measurement uncertainty (0 °C to 50 °C) for power measurements of a CW signal greater than -20 dBm with zero mismatch errors.
 - Expanded uncertainty with K=2 for power measurements of a CW signal greater than -20 dBm with zero mismatch errors.
 - Power uncertainty expressed with two sigma confidence level for CW measurement after zero operation. Includes calibration factor and linearity over temperature uncertainties, but not the effects of mismatch, zero set and drift, or noise.
 - Includes linearity over temperature uncertainties, but not the effects of calibration factor, mismatch, zero set and drift, and noise.



Interference Analyzer (Option 25)

Measurements

| | |
|---|---|
| Spectrum | Field Strength Occupied Bandwidth Channel Power Adjacent Channel Power (ACPR) AM/FM/SSB Demodulation (Wide/Narrow FM, Upper/Lower SSB), (audio out only) Carrier-to-Interference ratio (C/I) |
| Spectrogram | Collect data up to 72 hours |
| Signal Strength | Gives visual and aural indication of signal strength |
| Received Signal Strength Indicator (RSSI) | Collect data up to 168 hours (one week) |
| Interference Mapping | Draw multiple bearings of signal strength from GPS location on on-screen map Pan and Zoom on-screen maps Support for Anritsu MA2700A Handheld Interference Hunter |
| Impedance | 50 Ω, 75 Ω; external pad required for 75 Ω operation |



Channel Scanner (Option 27)

General

| | |
|--------------------|--|
| Number of Channels | 1 to 20 Channels (Power Levels) |
| Measurements | Graph/Table, Max Hold (On/5 s/Off), Frequency/Channel, Current/Maximum, Dual Color |
| Scanner | Scan Channels, Scan Frequencies, Scan Custom List, Scan Script Master™ |
| Amplitude | Reference Level, Scale |
| Custom Scan | Number of Channels, Signal Standard & Channel, Frequency, Bandwidth |
| Frequency Range | 9 kHz to 9 GHz |
| Frequency Accuracy | ± 10 Hz + frequency reference error |
| Measurement Range | -110 dBm to +30 dBm |
| Impedance | 50 Ω, 75 Ω; external pad required for 75 Ω operation |



Coverage Mapping (Option 431)

Measurements

| | |
|-----------------|------------|
| Indoor Mapping | RSSI, ACPR |
| Outdoor Mapping | RSSI, ACPR |

Setup Parameters

| | |
|------------------------------|--|
| Mode | Spectrum Analyzer |
| Frequency | Center, Span (ACPR only), Freq Step, Signal Standard, Channel #, Channel Increment |
| Amplitude | Reference Level (RL), Attenuation Auto/Level, RL Offset, Pre-Amp On/Off, Detection |
| Span | RSSI Mode: Zero Span ACPR Mode: Span, Span Up/Down (1-2-5), Full Span, Last Span |
| BW | RBW, Auto RBW, VBW, Auto VBW, RBW/VBW Ratio, Span/RBW Ratio |
| Measurement Setup | RSSI: Mapping color thresholds ACPR: Main Ch BW, Adj Ch BW, Ch Spacing, Adjacent Ch dB Offset, Thresholds for Good and Poor main channel levels |
| Mapping Colors | RSSI: Dark Green (Excellent), Light Green (Very Good), Yellow (Good), Orange (Fair), Dark Red (Poor) ACPR: Dark Green (Good), Yellow (between Good and Poor), Dark Red (Poor) |
| Point Distance or Time Setup | Repeat Type: Time (100 ms to 16 s), Distance (1 m to 10,000 m) Distance Units: m, ft |
| Save Points Map | Save KML, JPEG, Tab Delimited |
| Recall Points Map | Recall Map, Recall KML Points only, Recall KML Points with Map, Recall Default Grid |
| Map Types | Outdoor (GPS embedded), Indoor (non-GPS embedded). Import maps using the Anritsu easyMap Tools. Zoomable (.azm) maps are usable, but cannot be zoomed. |



GPS Receiver (Option 31) (requires external GPS antenna, sold separately)

| | |
|-----------------------------|---|
| Setup | On/Off, Antenna Voltage 3.3 V/5.0 V, GPS Info |
| GPS Time/Location Indicator | UTC Time, Latitude, Longitude, and Altitude on display (UTC Time and Altitude on GPS Info display) UTC Time, Latitude, Longitude, and Altitude with trace storage |
| High Frequency Accuracy | < $\pm 2.5 \times 10^{-8}$ Hz/Hz with GPS On, 3 minutes after satellite lock in selected mode (GPS Antenna connected) < $\pm 5.0 \times 10^{-8}$ Hz/Hz for 3 days after GPS lock, 0 °C to 50 °C (GPS Antenna disconnected) |
| Connector | SMA, female |



AM/FM/PM Signal Analyzer (Option 509)

Measurements

| Display Type | RF Spectrum (AM/FM/PM) | Audio Spectrum (AM) | Audio Spectrum (FM/PM) | Audio Waveform (AM) | Audio Waveform (FM/PM) | Summary (AM) | Summary (FM/PM) |
|--------------------|---|---|--|---|--|---|--|
| Graphic Display | Power (dBm) vs. Frequency | Depth (%) vs. Modulation Frequency | Deviation (kHz/rad) vs. Modulation Frequency | Depth (%) vs. Time | Deviation (kHz/rad) vs. Time | None | None |
| Numerical Displays | Carrier Power Carrier Frequency Occupied BW | AM Rate RMS Depth (Pk-Pk)/2 Depth SINAD* THD* Distortion/Total Vrms* | FM/PM Rate RMS Deviation (Pk-Pk)/2 Deviation SINAD* THD* Distortion/Total Vrms* | AM Rate RMS Depth (Pk-Pk)/2 Depth SINAD* THD* Distortion/Total Vrms* | FM/PM Rate RMS Deviation (Pk-Pk)/2 Deviation SINAD* THD* Distortion/Total Vrms* | RMS Depth Peak + Depth Peak - Depth (Pk-Pk)/2 Depth Carrier Power Carrier Frequency Occupied Bandwidth AM Rate SINAD* THD* Distortion/Total Vrms* | RMS Deviation Peak + Deviation Peak - Deviation (Pk-Pk)/2 Deviation Carrier Power Carrier Frequency Occupied Bandwidth FM/PM Rate SINAD* THD* Distortion/Total Vrms* |

* Requires sine wave modulation

Setup Parameters

| | |
|-------------------|---|
| Frequency | Center Freq, Span, Freq Step, Signal Standard, Channel, Channel Increment, Set (measured) Carrier Freq to Center |
| Amplitude Setup | Scale, Power Offset, Adjust Range |
| Measurements | RF Spectrum, Audio Spectrum (demodulated), Audio Waveform (demodulated), Summary, Coverage Mapping (Option 431 required), Audio Demod (AM/FM only) |
| Measurement Setup | All Measurements: Demod Type (AM, FM, PM), IFBW, Auto IFBW, Squelch Units, Distortion Measurements (Sinewave or Broadcast) RF Spectrum: OBW Method, OBW %, OBW dBC Audio Spectrum: Span, Scale, Squelch Power Audio Waveform: Sweep Time, Scale, Squelch Power Summary: Average count, Squelch Power Coverage Mapping: Measurement (SINAD, Carrier Power, Multiple), Thresholds, Point Distance/Time Audio Demod: Demod Type (AM, USB, LSB, Widband FM, Narrowband FM), Volume, Squelch |
| Mapping Colors | Dark Green (Excellent), Light Green (Very Good), Orange (Good), Yellow (Fair), Dark Red (Poor) |
| Marker | Six markers with Delta for each, Peak Search, Marker Freq to Center, Marker to Ref Lvl, Marker Table |

RF and Modulation Measurements

| | |
|----------------|---|
| AM | Modulation Rate: ± 1 Hz (< 100 Hz), ± 2 % (> 100 Hz) Depth: ± 5 % for (Modulation rates 10 Hz to 100 kHz) |
| FM | Modulation Rate: ± 1 Hz (< 100 Hz); ± 2 % (100 Hz to 100 kHz) Deviation Accuracy: ± 5 % (100 Hz to 100 kHz)** |
| PM | Modulation Rate: ± 1 Hz (< 100 Hz); ± 2 % (100 Hz to 100 kHz) Deviation Accuracy: ± 5 % (deviation 0 to 93 Rad, rate 10 Hz to 5 kHz)** |
| IF Bandwidth | 1 kHz to 300 kHz in 1-3 sequence |
| Frequency Span | RF Spectrum: 10 kHz to 10 MHz Audio Spectrum: 2 kHz, 5 kHz, 10 kHz, 20 kHz, 70 kHz, 140 kHz |
| RBW/VBW | 30 |
| Span/RBW | 100 |
| Sweep Time | 50 μ s to 50 ms (Audio Waveform) |
| ** | IFBW must be greater than 95 % occupied BW |



General Specifications

| | | |
|------------------------------|---|--|
| System Parameters | System | Status (Temperature, Battery Info, Serial Number, Firmware Version, IP Address, Options Installed) Self Test, Application Self Test, GPS (see Option 31) |
| | System Options | Name, Date and Time, Ethernet Configuration, Brightness, Volume, Language (English, French, German, Spanish, Chinese, Japanese, Korean, Italian, Russian, Portuguese), Reset (Factory Defaults, Master Reset, Update Firmware) |
| | Internal Trace/Setup Memory | Store more than 4000 traces and setups in memory |
| | External Trace/Setup Memory | Limited by size of USB Flash drive |
| | Mode Switching | Auto-Stores/Recalls most recently used Setup Parameters in the Mode |
| File Management | File Types | Vary with measurement mode |
| | File | Save, Recall, Copy, Delete |
| | Save | Setups, Measurements, Screen Shots (JPEG) |
| | Recall | Setups, Measurements |
| | Copy | Selected file or files to internal/external memory (USB) |
| | Delete | Selected file or files from internal/external memory (USB) |
| | File Sort Method | By Name/Date/Type, Ascend/Descend |
| Connectors | VNA Connectors | Type N, female |
| | Maximum Input (Damage Level) | Vector Network Analyzer Input: +23 dBm, ± 50 VDC Spectrum Analyzer Input: +30 dBm, ± 50 VDC |
| | Spectrum Analyzer Connectors | Type N, female |
| | Bias Tee | Type BNC female (enabled with Option 10) (x2) |
| | Ext Ref | Type BNC, female, 10 MHz, ± 10 dBm |
| | GPS | SMA female (available with Option 31 GPS) |
| | External Power | 5.5 mm barrel connector, 12 VDC to 14.5 VDC, < 5.0 A |
| | Ethernet | RJ45, 10/100 Mbps, Connect to PC or LAN for Remote Access |
| | USB Interface (2) | Type A, Connect Flash Drive and Power Sensor |
| | USB Interface | 5-pin mini-B, Connect to PC for data transfer |
| | Headset Jack | 3.5 mm 3-wire headset jack |
| | External Trigger | BNC, female, TTL 3.3 V or 5 V triggers on positive edge, Maximum Input + 5 VDC |
| 10 MHz Out | SMA, female, 50 Ω | |
| Display | Size | 8.4 in, daylight viewable color LCD |
| | Resolution | 800 x 600 |
| | Pixel Defects | No more than five defective pixels (99.9989% good pixels) |
| Power | Field replaceable Li-Ion Battery | 40 W when powered by factory 7500 mAh Li-Ion battery (part number: 633-75) |
| | AC/DC Power Adapter | 55 W when powered by supplied universal 110/220 V AC/DC adaptor while charging battery |
| | Life-time Charging Cycles | > 300 (80 % of initial capacity) |
| | Battery Operation | 3.0 hours typical |
| | Battery Charging Limits | 0 °C to +45 °C, Relative Humidity ≤ 80 %, non-condensing |
| Regulatory Compliance | European Union | EMC 2014/30/EU, EN 61326-1:2013 CISPR 11/EN 55011, IEC/EN 61000-4-2/3/4/5/6/8/11 Low Voltage Directive 2014/35/EU Safety EN 61010-1:2010 RoHS Directive 2011/65/EU + 2015/863 |
| | United Kingdom | EMC SI 2016/1091; BS EN 55011 & BS 61000-4-2/3/4/5/6/8/11 Consumer Protection (Safety) SI 2016/1101; BS EN 61010-1:2010 Environmental Protection SI 2012/3032; 2011/65/EU & 2015/863 |
| | Australia and New Zealand | RCM AS/NZS 4417:2012 |
| | South Korea | KCC-REM-A21+-0004 |
| | Canada | ICES-1(A)/NMB-1(A) |
| | Environmental | MIL-PRF-28800F Class 2 |
| | Operating Temperature Range | -10 °C to 55 °C |
| Storage Temperature Range | -51 °C to 71 °C | |
| Maximum Relative Humidity | 95 % RH at 30 °C, non-condensing | |
| Vibration, Sinusoidal | 5 Hz to 55 Hz | |
| Vibration, Random | 10 Hz to 500 Hz | |
| Half Sine Shock | 30 g _n | |
| Altitude | 4600 meters, operating and non-operating | |
| Explosive Atmosphere | MIL-PRF-28800F Section 4.5.6.3, MIL-STD-810G, Method 511.5, Procedure 1 | |

| | | |
|------------------------|---------------------------|---|
| Size and Weight | Dimensions | Height: 211 mm (8.3 in) Width: 315 mm (12.4 in) Depth: 97 mm (3.8 in) |
| | Weight, Including Battery | 4.8 kg (10.5 lb) |

| | |
|-----------------|--|
| Warranty | Standard three-year warranty One-year warranty on battery |
|-----------------|--|



Line Sweep Tools™ (for your PC)

| | | |
|----------------------|----------------------|--|
| Trace Capture | Browse to Instrument | View and copy traces from the test equipment to your PC using Windows Explorer |
| | Open Legacy Files | Open DAT files captured with Handheld Software Tools v6.61 |
| | Open Current Files | Open VNA or DAT files |
| | Capture Plots To | The Line Sweep Tools screen, DAT files, Database, or JPEG |

| | | |
|---------------|---------------|---|
| Traces | Trace Types | Return Loss, VSWR, DTF-RL, DTF-VSWR, Cable Loss, Smith Chart, and PIM |
| | Trace Formats | DAT, VNA, CSV, PNG, BMP, JPG, HTML, Database, and PDF |

| | | |
|--------------------------|------------------|--|
| Report Generation | Report Generator | Includes GPS location along with measurements |
| | Report Format | Create reports in HTML or PDF format |
| | Report Setup | Report Title, Company, Prepared for, Location, Date and Time, Filename, Company logo |
| | Trace Setup | 1 Trace Portrait Mode, 2 Trace Portrait Mode, 1 Trace Landscape Mode |

| | | |
|-------------------------|-------------------|--|
| Trace Validation | Presets | 7 presets allow "one click" setting of up to 6 markers and one limit line |
| | Marker Controls | 6 regular Markers, Marker Peak, Marker Valley, Marker between, and frequency entry |
| | Delta Markers | 6 Delta markers |
| | Limit Line | Enable and drag or value entry. Also works with presets |
| | Next Trace Button | Next Trace and Previous Trace arrow keys allow quick switching between traces |

| | | |
|--------------|------------------------|---|
| Tools | Cable Editor | Allows creation of custom cable parameters |
| | Distance to Fault | Converts a Return Loss trace to a Distance to Fault trace |
| | Measurement Calculator | Converts Real, Imaginary, Magnitude, Phase, RL, VSWR, Rho, and Transmit power |
| | Signal Standard Editor | Creates new band and channel tables |
| | Renaming Grid | 36 user-definable phrases for creation of file names, trace titles, and trace subtitles |

| | | |
|---------------------|-------------|--|
| Connectivity | Connections | Connect to PC using Serial, USB, or Ethernet |
| | Download | Download measurements and live traces to PC for storage and analysis |
| | Upload | Upload measurements from PC to instrument |



Master Software Tools (for your PC)

Measurement Viewing

| | |
|------------------------------------|--|
| Display | Modify display settings, including scale |
| Spectrum Traces | Add, delete, and modify limit lines and markers. Overlay traces. |
| Spectrum Analyzer Measurements | Field Strength, Occupied Bandwidth, Channel Power, ACPR, Emission Mask, C/I ¹ |
| Interference Analyzer Measurements | Spectrograms, Signal Strength Meter, RSSI ² |
| Non-Spectrum Measurements | Hi Accuracy Power Meter, Channel Scanner, GSM, WCDMA/HSPA, LTE, TD-LTE, TD-SCDMA, CDMA, EV-DO, Fixed WiMAX, Mobile WiMAX, Screen captures (JPEGs) |

1. Spurious Emissions results viewable in a browser
2. Coverage and Interference Mapping files are viewable in a spreadsheet, Google Earth, or Google Maps.

Database Management

| | |
|----------------------|---|
| Full Trace Retrieval | Retrieve all traces from instrument into one PC directory (limited to approximately 15,000 files) |
| Trace Catalog | Index all traces in selected folder & subfolder on PC into one catalog |
| Trace Rename Utility | Rename measurement traces |
| Group Edit | Titles, subtitles, plot scaling, markers and limit lines, simultaneously on similar files |

Data Analysis

| | |
|--------------------------|----------------------------|
| Trace Math and Smoothing | Compare multiple traces |
| Measurement Calculator | Translate into other units |

Report Generation

| | |
|---------------------|--|
| Report Generator | Includes GPS, power level, and measurements |
| Edit Graph | Change scale, limit lines, and markers |
| Report Format | Create reports in HTML |
| Export Measurements | Export measurements or entire folders to *.jpg or *.csv format |
| Notes | Annotate measurements |

Mapping (GPS required on instrument)

| | |
|------------------------|---------------------------|
| Spectrum Analyzer Mode | MapInfo |
| LTE Mode | Google Earth, Google Maps |

Spectrogram (Spectrum Monitoring for Interference Analysis and Spectrum Clearing)

| | |
|-----------------------------|---|
| Source | Recorded Spectrogram or multiple spectrum traces |
| Folder Spectrogram | 2D View creates a composite file of multiple traces |
| Available Displays | Spectrogram, Peak Power vs. Time, Variation in Total Power vs. Time, Peak Frequency vs. Time, Number of Traces Saved vs. Time (useful with Save on Limit Exceeded), Maximum/Average/Minimum Power vs. Time File Filter (Violations over limit lines or deviations from averages) Playback |
| Display Functions per Trace | Markers, GPS location altitude and time (when recorded), instrument time Filename per trace for Folder Spectrogram |
| Export to Video | Create AVI file of 2D Spectrogram for management review/reports |
| Export to 3D Spectrogram | Views (Set Threshold, Markers) - 3D (Rotate X, Y, Z Axis, Level Scale, Signal ID) - 2D (Frequency or Time Domain, Signal ID) - Top Down Playback (Frequency and/or Time Domain) |

List/Parameter Editors

| | |
|------------------------------------|--|
| Antennas, Cables, Signal Standards | Modify instrument's Antenna, Cable, and Signal Standard List |
| Pass/Fail | Create, download, or edit Signal Analysis Pass/Fail Limits |
| Script Master | Create Script Master files for GSM/WCDMA or Channel Scanner |
| Languages | Modify non-English language menus |
| Mobile WiMAX | DL-MAP Parameters |

Connectivity

| | |
|--------------------|--|
| Connections | Connect to PC using USB, LAN, or Direct Ethernet connection |
| Network Search | Find all Anritsu handheld instruments on local network |
| Download | Download measurements and live traces to PC for storage and analysis |
| Upload | Upload measurements and other files from PC to instrument |
| Remote Access Tool | Remote control and monitoring of instrument (via Ethernet port) over the Internet |
| Export | Measurements can be saved in various formats, depending on the measurement type, including JPEG, CSV, and Anritsu DAT format |
| Printing | Print individual or all measurement screens |

Ordering Information

VNA Master™ Handheld Vector Network Analyzer + Spectrum Analyzer



| MS2036C | Description |
|----------------|--|
| 5 kHz to 6 GHz | Vector Network Analyzer |
| 9 kHz to 9 GHz | Spectrum Analyzer |
| MS2036C-0002 | Time Domain (includes Distance Domain capabilities) |
| MS2036C-0007 | Secure Data Operation |
| MS2036C-0010 | Built-in Bias-Tee |
| MS2036C-0015 | Vector Voltmeter |
| MS2036C-0019 | High Accuracy Power Meter (requires external USB sensor) |
| MS2036C-0025 | Interference Analysis, ^a 9 kHz to 9/15/20 GHz |
| MS2036C-0027 | Channel Scanner, ^a 9 kHz to 9/15/20 GHz |
| MS2036C-0031 | GPS Receiver (requires GPS antenna, 2000-1528-R, 2000-1652-R, or 2000-1760-R) |
| MS2036C-0077 | Balanced/Differential S-Parameters, 1-Port |
| MS2036C-0431 | Coverage Mapping ^b |
| MS2036C-0098 | Standard Calibration to ISO17025 and ANSI/NCSL Z540-1. Includes calibration certificate. |
| MS2036C-0099 | Premium Calibration to ISO17025 and ANSI/NCSL Z540-1. Includes calibration certificate, test report, and uncertainty data. |
| MS2036C-0509 | AM/FM/PM Analyzer ^c |

a.Option 31 (GPS) is recommended.

b.Requires Option 31 (GPS) for full functionality.







c.Requires Option 431 (Coverage Mapping) for full functionality.





Standard Accessories (included with instrument)

| Accessory | Description |
|---|---|
|  | 2000-1686-R Soft Carrying Case |
|  | 3-2000-1498 USB A/5-pin mini-B Cable, 10 ft |
|  | 633-75 Rechargeable Li-Ion Battery, 7500 mAh |











| Accessory | Description |
|---|--|
|  | 806-141-R Automotive Power Adapter, 12 VDC, 60 W |
|  | 2000-1371-R Ethernet Cable, 7 ft (213 cm) |
|  | 40-187-R AC-DC Adapter with AC power cord (country dependent) |

USB Power Sensors (for complete ordering information, see the respective data sheets of each sensor)

| Accessory | Description |
|---|--|
|  | MA24330A Microwave CW USB Power Sensor, 10 MHz to 33 GHz, +20 dBm |
|  | MA24340A Microwave CW USB Power Sensor, 10 MHz to 40 GHz, +20 dBm |
|  | MA24350A Microwave CW USB Power Sensor, 10 MHz to 50 GHz, +20 dBm |
|  | MA24208A Microwave Universal USB Power Sensor, 10 MHz to 8 GHz, +20 dBm to -60 dBm |
|  | MA24218A Microwave Universal USB Power Sensor, 10 MHz to 18 GHz, +20 dBm to -60 dBm |
|  | MA24106A High Accuracy RF Power Sensor, 50 MHz to 6 GHz, +23 dBm to -40 dBm |

| Accessory | Description |
|---|---|
|  | MA24108A Microwave USB Power Sensor, 10 MHz to 8 GHz, +20 dBm to -40 dBm |
|  | MA24118A Microwave USB Power Sensor, 10 MHz to 18 GHz, +20 dBm to -40 dBm |
|  | MA24126A Microwave USB Power Sensor, 10 MHz to 26 GHz, +20 dBm to -40 dBm |
|  | MA24105A Inline Dual Directional High Power Sensor, 350 MHz to 4 GHz, +3 dBm to +51.76 dBm |
|  | MA25100A RF Power Indicator |

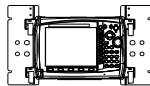
Optional Accessories

| Backpack and Transit Case | | Accessory | Description |
|---|--|---|--|
|  | 67135 Anritsu Backpack (for Handheld Instrument and PC) |  | 760-261-R Large Transit Case with Wheels and Handle 63.1 cm x 50 cm x 30 cm (24.83" x 19.69" x 11.88"), space for MA2700A, antennas, filters, instrument inside soft case, and other interference hunting accessories/tools |
|  | 760-243-R Large Transit Case with Wheels and Handle 56 cm x 45.5 cm x 26.5 cm (22.07" x 17.92" x 10.42") |  | 760-262-R Transit Case for MA2700A, holds several Yagi antennas and filters/port extender 96.8 x 40.6 x 15.5 cm (38.12" x 16.00" x 6.12") |
|  | 760-286-R Compact Transit Case with Wheels and Handle 55.6 cm x 35.5 cm x 22.9 cm (21.89" x 13.98" x 9.01") |  | 760-271-R Transit Case for Portable Directional Antennas and Port Extender 52.4 cm x 42.8 cm x 20.6 cm (20.62" x 16.87" x 8.12") (for 2000-1777-R, 2000-1778-R, 2000-1779-R, 2000-1798-R) |
| Miscellaneous Accessories | | Accessory | Description |
|  | MA2700A Handheld Interference Hunter (For full specifications, refer to the MA2700A Technical Data Sheet 11410-00692) |  | 2000-1689-R EMI Near Field Probe Kit |
|  | 3-806-152 Cat 5e Crossover Patch Cable, 2.1 m (7 ft) |  | 66864 Rack Mount Kit, Master Platform |
|  | 2000-1374-R External Dual Charger for Li-Ion Batteries | | |

Full Temperature Coaxial Calibration Kits -10 °C to +55 °C, K Type is compatible with 3.5 mm and SMA connectors see individual data sheets on www.anritsu.com)

| Accessory | Description | Accessory | Description |
|---|--|---|---|
|  | OSLN50A-8 High Performance Type N(m), DC to 8 GHz, 50 Ω |  | OSLNF50A-8 High Performance Type N(f), DC to 8 GHz, 50 Ω |
|  | OSLN50A-18 High Performance Type N(m), DC to 18 GHz, 50 Ω |  | OSLNF50A-18 High Performance Type N(f), DC to 18 GHz, 50 Ω |
|  | TOSLN50A-8 High Performance with Through Type N(m), DC to 8 GHz, 50 Ω |  | TOSLNF50A-8 High Performance with Through Type N(f), DC to 8 GHz, 50 Ω |
|  | TOSLN50A-18 High Performance with Through Type N(m), DC to 18 GHz, 50 Ω |  | TOSLNF50A-18 High Performance with Through Type N(f), DC to 18 GHz, 50 Ω |
|  | TOSLK50A-20 High Performance with Through Type K(m), DC to 20 GHz, 50 Ω |  | TOSLKF50A-20 High Performance with Through Type K(f), DC to 20 GHz, 50 Ω |
|  | TOSLK50A-40 High Performance with Through Type K(m), DC to 40 GHz, 50 Ω |  | TOSLKF50A-40 High Performance with Through Type K(f), DC to 40 GHz, 50 Ω |

Coaxial Calibration Components, N Type 50 Ω, K Type 50 Ω (K Type is compatible with 3.5 mm and SMA connectors)

| Accessory | Description | Accessory | Description |
|---|--|-----------|-------------|
|  | 28N50-2 Precision Load, N(m), DC to 8 GHz, 50 Ω | | |

Coaxial Calibration Components, Other 50 Ω, 75 Ω

| Accessory | Description |
|---|--|
|  | 22N75 Open/Short, N(m), DC to 3 GHz, 75 Ω |
|  | 26N75A Precision Termination, N(m), DC to 3 GHz, 75 Ω |
|  | 12N50-75B Matching Pad, DC to 3 GHz, 50 Ω to 75 Ω |
|  | 2000-1619-R Precision Open/Short/Load, 7/16 DIN(f), DC to 6.0 GHz, 50 Ω |
|  | 2000-1915-R Precision Open/Short/Load, 4.3-10(m), DC to 6 GHz, 50 Ω |
|  | SM/PLNF-1 Precision N(f) Load, 42 dB, 6 GHz |
| | 1091-53-R Open, TNC(m), DC to 18 GHz |
| | 1091-54-R Short, TNC(m), DC to 18 GHz |
| | 1015-55-R Termination, TNC(m), DC to 18 GHz |

| Accessory | Description |
|---|--|
|  | 22NF75 Open/Short, N(f), DC to 3 GHz, 75 Ω |
|  | 26NF75A Precision Termination, N(f), DC to 3 GHz, 75 Ω |
|  | 2000-1618-R Precision Open/Short/Load, 7/16 DIN(m), DC to 6.0 GHz, 50 Ω |
|  | 2000-1914-R Precision Open/Short/Load, 4.3-10(f), DC to 6 GHz, 50 Ω |
|  | SM/PL-1 Precision N(m) Load, 42 dB, 6 GHz |
| | 1091-55-R Open, TNC(f), DC to 18 GHz |
| | 1091-56-R Short, TNC(f), DC to 18 GHz |
| | 1015-54-R Termination, TNC(f), DC to 18 GHz |

| Precision Adapters | | Accessory | |
|---|---|---|---|
| Accessory | Description | Accessory | Description |
|  | 34NN50A N(m) to N(m), DC to 18 GHz, 50 Ω |  | 34NFN50 N(f) to N(f), DC to 18 GHz, 50 Ω |
|  | 34NK50 DC to 18 GHz, N(m) to K(m), 50 Ω |  | 34NFK50 DC to 18 GHz, N(m) to K(f), 50 Ω |
|  | K220B DC to 40 GHz, K(m) to K(m), 50 Ω |  | K222B DC to 40 GHz, K(f) to K(f), 50 Ω |
|  | K224B DC to 40 GHz, K(m) to K(f), 50 Ω | | |

Waveguide Calibration Components and WG/Coaxial Adapters, Rectangular Type 50 Ω

Recommended waveguide calibration procedure requires two offset shorts and a precision load. The waveguide/coax adapter, shown attached to test port #1, adapts the VNA Master test ports to the waveguide under test.

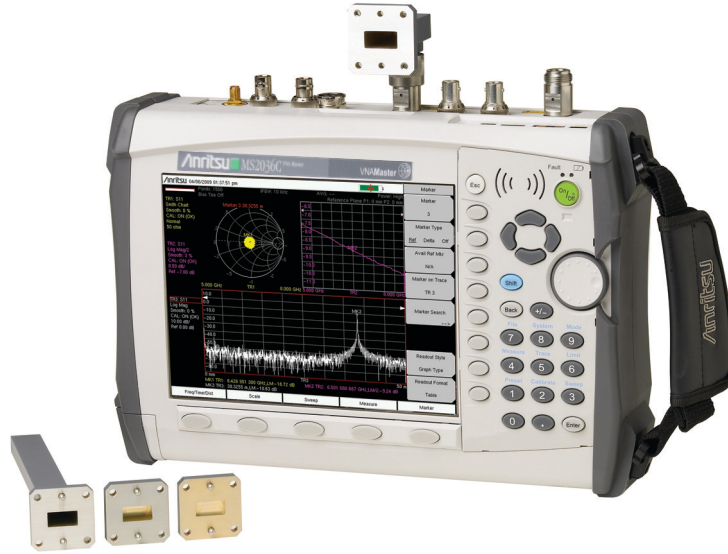

| Frequency Range (GHz) | 1/8 Offset | 3/8 Offset | Termination | Coax to Waveguide Adapter | Compatible Flanges |
|-----------------------|------------|------------|-------------|---------------------------|--|
| 3.95 to 5.85 | 23UA187-R | 24UA187-R | 26UA187-R | 35UA187N-R | CPR187F-R, CPR187G-R, UG-1352/U-R, UG-1353/U-R, UG-1728/U-R, UG-1729/U-R, UG-148/U-R, UG-149A/U-R |
| 5.85 to 8.20 | 23UA137-R | 24UA137-R | 26UA137-R | 35UA137N-R | CPR137F-R, CPR137G-R, UG-1356/U-R, UG-1357/U-R, UG-1732/U-R, UG-1733/U-R, UG-343B/U-R, UG-344/U-R, UG-440B/U-R, UG-441/U-R |
| 7.05 to 10.00 | 23UA112-R | 24UA112-R | 26UA112-R | 35UA112N-R | CPR112F-R, CPR112G-R, UG-1358/U-R, UG-1359/U-R, UG-1734/U-R, UG-1735/U-R, UG-52B/U-R, UG-51/U-R, UG-137B/U-R, UG-138/U-R |
| 8.20 to 12.40 | 23UA90-R | 24UA90-R | 26UA90-R | 35UA90N-R | CPR90F-R, CPR90G-R, UG-1360/U-R, UG-1361/U-R, UG-1736/U-R, UG-1737/U-R, UG-40B/U-R, UG-39/U-R, UG-135/U-R, UG-136B/U-R |
| 12.40 to 18.00 | 23UA62-R | 24UA62-R | 26UA62-R | 35UA62N-R | UG-541A/U-R, UG-419/U-R, UG-1665/U-R, UG1666/U-R |
| 17.00 to 26.50 | 23UA42-R | 24UA42-R | 26UA42-R | 35UA42K-R | UG-596A/U-R, UG-595/U-R, UG-597/U-R, UG-598A/U-R |
| 26.50 to 40.00 | 23UA28-R | 24UA28-R | 26UA28-R | 35UA28K-R | UG-599/U-R |
| 3.30 to 4.90 | 23UM40-R | 24UM40-R | 26UM40-R | 35UM40N-R | PDR40-R |
| 3.95 to 5.85 | 23UM48-R | 24UM48-R | 26UM48-R | 35UM48N-R | CAR48-R, PAR48-R, UAR48-R, PDR48-R |
| 5.85 to 8.20 | 23UM70-R | 24UM70-R | 26UM70-R | 35UM70N-R | CAR70-R, PAR70-R, UAR 70-R, PDR70-R |
| 7.05 to 10.00 | 23UM84-R | 24UM84-R | 26UM84-R | 35UM84N-R | CBR84-R, UBR84-R, PBR84-R, PDR84-R |
| 8.20 to 12.40 | 23UM100-R | 24UM100-R | 26UM100-R | 35UM100N-R | CBR100-R, UBR100-R, PBR100-R, PDR100-R |
| 10.00 to 15.00 | 23UM120-R | 24UM120-R | 26UM120-R | 35UM120N-R | CBR120-R, UBR120-R, PBR120-R, PDR120-R |
| 12.40 to 18.00 | 23UA140-R | 24UA140-R | 26UA140-R | 35UA140N-R | CBR140-R, UBR140-R, PBR140-R, PDR140-R |
| 17.00 to 26.50 | 23UA220-R | 24UA220-R | 26UA220-R | 35UA220K-R | CBR220-R, UBR220-R, PBR220-R, PDR220-R |

* For Coaxial/Waveguide Adapter part numbers, N designates Type N and K designates K-Connector

Phase-Stable Test Port Cables, Armored

| Accessory | Description |
|---|--|
|  | 15NNF50-1.5C 1.5 m, DC to 6 GHz, N(m) to N(f), 50 Ω |
| | 15NN50-1.5C 1.5 m, DC to 6 GHz, N(m) to N(m), 50 Ω |
| | 15NNF50-3.0C 3.0 m, DC to 6 GHz, N(m) to N(f), 50 Ω |
| | 15NN50-3.0C 3.0 m, DC to 6 GHz, N(m) to N(m), 50 Ω |
| | 15NNF50-5.0C 5.0 m, DC to 6 GHz, N(m) to N(f), 50 Ω |
| | 15NN50-5.0C 5.0 m, DC to 6 GHz, N(m) to N(m), 50 Ω |

| Accessory | Description |
|-----------|-------------|
|-----------|-------------|

| | |
|---|--|
|  | 15NDF50-1.5C 1.5 m, DC to 6 GHz, N(m) to 7/16 DIN(f), 50 Ω |
| | 15ND50-1.5C 1.5 m, DC to 6 GHz, N(m) to 7/16 DIN(m), 50 Ω |
| | 15N43M50-1.5C Test Port Extension Cable, Armored, 1.5 m, DC to 6 GHz, N(m) to 4.3-10(m) |
| | 15N43F50-1.5C Test Port Extension Cable, Armored, 1.5 m, DC to 6 GHz, N(m) to 4.3-10(f) |
| | 15N43M50-3.0C Test Port Extension Cable, Armored, 3 m, DC to 6 GHz, N(m) to 4.3-10(m) |
| | 15N43F50-3.0C Test Port Extension Cable, Armored, 3 m, DC to 6 GHz, N(m) to 4.3-10(f) |

Phase-Stable 18 GHz and 40 GHz Semi-Rigid Cables (Armored)

| Accessory | Description |
|---|---|
|  | 3670K50A-1 0.3 m (12 in), DC to 40 GHz, K(f) to K(m), 50 Ω |
| | 3670K50A-2 0.6 m (24 in), DC to 40 GHz, K(f) to K(m), 50 Ω |
| | 3670NN50-1 0.3 m (12 in), DC to 18 GHz, N(m) to N(m), 50 Ω |
| | 3670NN50-2 0.6 m (24 in), DC to 18 GHz, N(m) to N(m), 50 Ω |

| Accessory | Description |
|--|-------------|
| 3670N50-1 0.3 m (12 in), DC to 18 GHz, N(f) to N(m), 50 Ω | |
| 3670N50-2 0.6 m (24 in), DC to 18 GHz, N(f) to N(m), 50 Ω | |

Attenuators N Type (up to 18 GHz)



| Accessory | Description |
|---|--|
|  | 1010-121-R 40 dB, 100 W, DC to 18 GHz, N(f) to N(m), Uni-directional |
|  | 3-1010-122 20 dB, 5 W, DC to 12.4 GHz, N(m) to N(f) |
|  | 3-1010-123 30 dB, 50 W, DC to 8.5 GHz, N(m) to N(f) |
|  | 3-1010-124 Attenuator, 40 dB, 100 W, DC to 8.5 GHz, N(f) to N(m), Uni-directional |

| Accessory | Description |
|---|---|
|  | 42N50-20 20 dB, 5 W, DC to 18 GHz, N(m) to N(f) |
|  | 42N50A-30 30 dB, 50 W, DC to 18 GHz, N(m) to N(f) |
|  | 1010-127-R 30 dB, 150 W, DC to 3 GHz, N(m) to N(f) |
|  | 1010-128-R 40 dB, 150 W, DC to 3 GHz, N(m) to N(f) |

| Adapters Accessory | Description |
|---|--|
|  | 1091-26-R SMA(m) to N(m), DC to 18 GHz, 50 Ω |
|  | 1091-27-R SMA(f) to N(m), D to 18 GHz, 50 Ω |
|  | 1091-80-R SMA(m) to N(f), DC to 18 GHz, 50 Ω |
|  | 1091-81-R SMA(f) to N(f), DC to 18 GHz, 50 Ω |
|  | 1091-172-R BNC(f) to N(m), DC to 1.3 GHz, 50 Ω |
|  | 1091-465-R Adapter, DC to 6 GHz, 4.3-10(f) to N(f), 50 Ω |
|  | 510-96-R 7/16 DIN(m) to 7/16 DIN (m), DC to 7.5 GHz, 50 Ω |
| | 1091-315-R DC to 18 GHz, TNC(m) to N(f), 50 Ω |
| | 1091-324-R DC to 18 GHz, TNC(f) to N(m), 50 Ω |
| | 1091-317-R DC to 18 GHz, TNC(m) to SMA(f), 50 Ω |
| | 1091-318-R DC to 18 GHz, TNC(m) to SMA(m), 50 Ω |









| Accessory | Description |
|---|---|
|  | 510-102-R N(m) to N(m), DC to 11 GHz, 50 Ω, 90 degrees, 50 Ω |
|  | 510-90-R 7/16 DIN(f) to N(m), DC to 7.5 GHz, 50 Ω |
|  | 510-91-R 7/16 DIN(f) to N(f), DC to 7.5 GHz, 50 Ω |
|  | 510-92-R 7/16 DIN(m) to N(m), DC to 7.5 GHz, 50 Ω |
|  | 510-93-R 7/16 DIN(m) to N(f), DC to 7.5 GHz, 50 Ω |
|  | 1091-467-R Adapter, DC to 6 GHz, 4.3-10(m) to N(f), 50 Ω |
|  | 510-97-R 7/16 DIN(f) to 7/16 DIN (f), DC to 7.5 GHz, 50 Ω |
| | 1091-323-R DC to 18 GHz, TNC(f) to TNC(f), 50 Ω |
| | 1091-326-R DC to 18 GHz, TNC(m) to TNC(m), 50 Ω |
|  | 34RKNF50 DC to 18 GHz, Ruggedized K(m) to N(f), 50 Ω |
| | 513-62-R DC to 18 GHz, TNC(f) to N(f), 50 Ω |

GPS Antennas (active)

| Accessory | Description |
|---|--|
|  | 2000-1528-R Magnet Mount, SMA(m) with 5 m (16.4 ft) cable, requires 5 VDC |
|  | 2000-1652-R Magnet Mount, SMA(m) with 0.3 m (1 ft) cable, requires 3.3 VDC or 5 VDC |



| Accessory | Description |
|---|---|
|  | 2000-1760-R Miniature Antenna, SMA(m), requires 2.5 VDC to 3.7 VDC |

Directional Antennas

| Accessory | Description |
|---|--|
|  | 2000-1411-R 824 MHz to 896 MHz, N(f), 12.3 dBi, Yagi |
|  | 2000-1412-R 885 MHz to 975 MHz, N(f), 12.6 dBi, Yagi |
|  | 2000-1413-R 1710 MHz to 1880 MHz, N(f), 12.3 dBi, Yagi |
|  | 2000-1414-R 1850 MHz to 1990 MHz, N(f), 11.4 dBi, Yagi |
|  | 2000-1415-R 2400 MHz to 2500 MHz, N(f), 14.1 dBi, Yagi |
|  | 2000-1416-R 1920 MHz to 2170 MHz, N(f), 14.3 dBi, Yagi |
|  | 2000-1659-R 698 MHz to 787 MHz, N(f), 10.1 dBi, Yagi |
|  | 2000-1660-R 1425 MHz to 1535 MHz, N(f), 14.3 dBi, Yagi |
|  | 2000-1715-R 698 MHz to 2500 MHz, N(f), gain of 2 dBi to 10 dBi, typical |

| Accessory | Description |
|---|---|
|  | 2000-1726-R 2500 MHz to 2700 MHz, N(f), 14.1 dBi, Yagi |
|  | 2000-1747-R Log Periodic, 300 MHz to 7000 MHz, N(f), 5.1 dBi, typical |
|  | 2000-1748-R Log Periodic, 1 GHz to 18 GHz, N(f), 6 dBi, typical |
|  | 2000-1777-R 9 kHz to 20 MHz, N(f) (requires port extender 2000-1798-R when used with MA2700A) |
|  | 2000-1778-R 20 MHz to 200 MHz, N(f) (requires port extender 2000-1798-R when used with MA2700A) |
|  | 2000-1779-R 200 MHz to 500 MHz, N(f) (requires port extender 2000-1798-R when used with MA2700A) |
|  | 2000-1812-R Portable Yagi Antenna, 450 MHz to 512 MHz, N(f), 7.1 dBi |
|  | 2000-1825-R Portable Yagi Antenna, 380 MHz to 430 MHz, N(f), 7.1 dBi |
|  | 2000-1798-R Port Extender, DC to 6 GHz |

Mag Mount and Broadband Antennas

| Accessory | Description |
|---|---|
|  | 2000-1616-R 20 MHz to 21000 MHz, N(f), 50 Ω |
|  | 2000-1646-R 750 MHz to 1250 MHz, 3 dBi peak gain, 1650 MHz to 2000 MHz, 5 dBi peak gain, 2100 MHz to 2700 MHz, 5 dBi peak gain, N(m), 50 Ω, 10 ft |
|  | 2000-1648-R 1700 MHz to 6000 MHz, 3 dBi peak gain, N(m), 50 Ω, 10 ft |

| Accessory | Description |
|---|--|
|  | 2000-1645-R 694 MHz to 894 MHz, 3 dBi peak gain 1700 MHz to 2700 MHz, 3 dBi peak gain, N(m), 50 Ω, 10 ft |
|  | 2000-1647-R Cable 1: 698 MHz to 1200 MHz, 2 dBi peak gain, 1700 MHz to 2700 MHz, 5 dBi peak gain, N(m), 50 Ω, 10 ft Cable 2: 3000 MHz to 6000 MHz, 5 dBi peak gain, N(m), 50 Ω, 10 ft Cable 3: GPS 26 dB gain, SMA(m), 50 Ω, 10 ft |
|  | 2000-1946-R Cable 1: 617 MHz to 960 MHz, 3 dBi peak gain, 1710 MHz to 3700 MHz, 4 dBi peak gain, N(m), 50 Ω, 10 ft Cable 2: 3000 MHz to 6000 MHz, 5 dBi peak gain, N(m), 50 Ω, 10 ft Cable 3: GPS 26 dB gain, SMA(m), 50 Ω, 10 ft |

Portable Antennas (requires 1091-27-R SMA(f) to N(m) or 1091-172-R BNC(f) to N(m) adapter)

| Accessory | Description |
|---|---|
|  | 2000-1200-R 806 MHz to 866 MHz, SMA(m), 50 Ω |
|  | 2000-1473-R 870 MHz to 960 MHz, SMA(m), 50 Ω |
|  | 2000-1035-R 896 MHz to 941 MHz, SMA(m), 50 Ω (1/2 wave) |
|  | 2000-1030-R 1710 MHz to 1880 MHz, SMA(m), 50 Ω (1/2 wave) |
|  | 2000-1474-R 1710 MHz to 1880 MHz with knuckle elbow (1/2 wave) |
|  | 2000-1031-R 1850 MHz to 1990 MHz, SMA(m), 50 Ω (1/2 wave) |

| Accessory | Description |
|---|--|
|  | 2000-1475-R 1920 MHz to 1980 MHz and 2110 MHz to 2170 MHz, SMA(m), 50 Ω |
|  | 2000-1032-R 2400 MHz to 2500 MHz, SMA(m), 50 Ω (1/2 wave) |
|  | 2000-1751-R 698 MHz to 960 MHz, 1710 MHz to 2100 MHz, 2500 MHz to 2700 MHz, SMA(m), 2 dB, typical, 50 Ω |
|  | 2000-1361-R 2400 MHz to 2500 MHz, 5000 MHz to 6000 MHz, SMA(m), 50 Ω |
|  | 2000-1636-R Antenna Kit (Consists of: 2000-1030-R, 2000-1031-R, 2000-1032-R, 2000-1200-R, 2000-1035-R, 2000-1361-R, and carrying pouch) |
|  | 2000-1487-R VHF/UHF, Telescopic Whip antenna, straight or 90°, BNC(m), 50 Ω |



Bandpass Filters

| Accessory | Description |
|---|--|
| | 1030-114-R 806 MHz to 869 MHz, N(m) to SMA(f), 50 Ω |
| | 1030-109-R 824 MHz to 849 MHz, N(m) to SMA(f), 50 Ω |
| | 1030-110-R 880 MHz to 915 MHz, N(m) to SMA(f), 50 Ω |
| | 1030-111-R 1850 MHz to 1910 MHz, N(m) to SMA(f), 50 Ω |
| | 1030-112-R 2400 MHz to 2484 MHz, N(m) to SMA(f), 50 Ω |
| | 1030-105-R 890 MHz to 915 MHz, N(m) to N(f), 50 Ω |
| | 1030-106-R 1710 MHz to 1790 MHz, N(m) to N(f), 50 Ω |
| | 1030-107-R 1910 MHz to 1990 MHz, N(m) to N(f), 50 Ω |
|  | 1030-149-R High Pass, 150 MHz, N(m) to N(f), 50 Ω |
| | 1030-150-R High Pass, 400 MHz, N(m) to N(f), 50 Ω |
| | 1030-151-R High Pass, 700 MHz, N(m) to N(f), 50 Ω |
| | 1030-152-R Low Pass, 200 MHz, N(m) to N(f), 50 Ω |
| | 1030-153-R Low Pass, 550 MHz, N(m) to N(f), 50 Ω |
| | 1030-155-R 2500 MHz to 2700 MHz, N(m) to N(f), 50 Ω |
| | 1030-178-R 1920 MHz to 1980 MHz, N(m) to N(f), 50 Ω |
| | 1030-179-R 777 MHz to 798 MHz, N(m) to N(f), 50 Ω |
| | 1030-180-R 2500 MHz to 2570 MHz, N(m) to N(f), 50 Ω |

Accessory Description

| Accessory | Description |
|---|--|
| | 2000-1734-R 699 MHz to 715 MHz, N(m) and N(f), 50 Ω |
| | 2000-1735-R 776 MHz to 788 MHz, N(m) and N(f), 50 Ω |
| | 2000-1736-R 815 MHz to 850 MHz, N(m) and N(f), 50 Ω |
| | 2000-1737-R 1711 MHz to 1756 MHz, N(m) and N(f), 50 Ω |
| | 2000-1738-R 1850 MHz to 1910 MHz, N(m) and N(f), 50 Ω |
| | 2000-1739-R 880 MHz to 915 MHz, N(m) and N(f), 50 Ω |
| | 2000-1740-R 1710 MHz to 1785 MHz, N(m) and N(f), 50 Ω |
|  | 2000-1741-R 1920 MHz to 1980 MHz, N(m) and N(f), 50 Ω |
| | 2000-1742-R 832 MHz to 862 MHz, N(m) and N(f), 50 Ω |
| | 2000-1743-R 2500 MHz to 2570 MHz, N(m) and N(f), 50 Ω |
| | 2000-1799-R 2305 MHz to 2320 MHz, N(m) and N(f), 50 Ω |
| | 2000-1911-R 703 MHz to 748 MHz, N(m) and N(f), 50 Ω |
| | 2000-1912-R 788 MHz to 798 MHz, N(m) and N(f), 50 Ω |
| | 2000-1925-R 663 MHz to 698 MHz, N(m) and N(f), 50 Ω |
| | 2000-1926-R 776 MHz to 806 MHz, N(m) and N(f), 50 Ω |
|  | 2000-1684-R 791 MHz to 821 MHz, N(m) to N(f), 50 Ω |

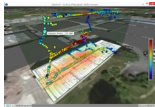
NEON® MA8100A Signal Mapper

| Accessory | Description | Accessory | Description |
|--|--|-----------|---|
| | MA8100A-000 NEON Signal Mapper with Anritsu Integration and Tracking Unit. Includes 3 months NEON Software License with 3 months of maintenance and support and 3 months of Cloud Service (PN: 2300-607). | | 2300-606 Perpetual NEON Software License with 3 years of maintenance and support and 3 years of Cloud Service. Part number can also be used to order a perpetual license after a limited term license has expired. |
| | MA8100A-001 NEON Signal Mapper with Anritsu Integration and Tracking Unit. Includes 1 year NEON Software License with 1 year of maintenance and support and 1 year of Cloud Service (PN: 2300-574). | | 2300-612 Renewal of 1 year NEON Software License with 1 year of maintenance and support and 1 year of Cloud Service. |
|  | MA8100A-003 NEON Signal Mapper with Anritsu Integration and Tracking Unit. Includes 3 year NEON Software License with 3 years of maintenance and support and 3 years of Cloud Service (PN: 2300-575). | | 2300-613 Renewal of 3 year NEON Software License with 3 years of maintenance and support and 3 years of Cloud Service. |
| | MA8100A-005 NEON Signal Mapper with Anritsu Integration and Tracking Unit. Includes 5 year NEON Software License with 5 years of maintenance and support and 5 years of Cloud Service (PN: 2300-576). | | 2300-614 Renewal of 5 year NEON Software License with 5 years of maintenance and support and 5 years of Cloud Service. |
| | MA8100A-100 NEON Signal Mapper with Anritsu Integration and Tracking Unit. Includes Perpetual NEON Software License with 3 years of maintenance and support and 3 years of Cloud Service (PN: 2300-606). | | |
|  | 2000-1852-R NEON Tracking Unit (includes USB cable and belt clip, Worldwide version) | | |
| | 2000-2015-R NEON Tracking Unit (includes USB cable and belt clip, Japan version) | | |
| | 2000-1853-R Belt clip (for NEON Tracking Unit) | | |

Related Literature, Application Notes, Manuals

| Part Number | Description |
|-------------|---|
| 10100-00065 | Product Information, Compliance, and Safety |
| 10580-00349 | Spectrum Analyzer Measurement Guide |
| 10580-00240 | Power Meter Measurement Guide |
| 10580-00289 | VNA Measurement Guide |
| 10580-00305 | VNA Master User Guide |
| 10580-00306 | VNA Master Programming Manual |
| 10580-00307 | VNA Master Maintenance Manual |
| 11410-00424 | USB Power Sensor MA24106A |
| 11410-00472 | Measuring Interference |
| 11410-00504 | Microwave USB Power Sensor MA241x8A |
| 11410-00531 | Practical Tips on Making "Vector Voltmeter (VVM)" Phase Measurements using VNA Master (Option 15) |
| 11410-00545 | VNA Master + Spectrum Analyzer Brochure |
| 11410-00549 | VNA Master + Spectrum Analyzer Technical Data Sheet |

Training at Anritsu

Anritsu has designed courses to help you stay up to date with technologies important to your job. For available training courses, visit: www.anritsu.com and search for training and education.



• United States

Anritsu Americas Sales Company
450 Century Parkway, Suite 190,
Allen, TX 75013, U.S.A.
Phone: +1-800-Anritsu (1-800-267-4878)

• Canada

Anritsu Electronics Ltd.
700 Silver Seven Road, Suite 120,
Kanata, Ontario K2V 1C3, Canada
Phone: +1-613-591-2003
Fax: +1-613-591-1006

• Brazil

Anritsu Eletronica Ltda.
Praça Amadeu Amaral, 27 - 1 Andar
01327-010 - Bela Vista - Sao Paulo - SP, Brazil
Phone: +55-11-3283-2511
Fax: +55-11-3288-6940

• Mexico

Anritsu Company, S.A. de C.V.
Blvd Miguel de Cervantes Saavedra #169 Piso 1,
Col. Granada, Mexico, Ciudad de Mexico,
11520, MEXICO
Phone: +52-55-4169-7104

• United Kingdom

Anritsu EMEA Ltd.
200 Capability Green,
Luton, Bedfordshire, LU1 3LU, U.K.
Phone: +44-1582-433200
Fax: +44-1582-731303

• France

Anritsu S.A.
12 avenue du Québec, Immeuble Goyave,
91140 VILLEBON SUR YVETTE, France
Phone: +33-1-60-92-15-50

• Germany

Anritsu GmbH
Nemetschek Haus, Konrad-Zuse-Platz 1,
81829 München, Germany
Phone: +49-89-442308-0
Fax: +49-89-442308-55

• Italy

Anritsu S.r.l.
Spaces Eur Arte, Viale dell'Arte 25, 00144 Roma, Italy
Phone: +39-6-509-9711

• Sweden

Anritsu AB
Kistagången 20 B, 2 tr, 164 40 Kista, Sweden
Phone: +46-8-534-707-00

• Finland

Anritsu AB
Technopolis Aviapolis, Teknobulevardi 3-5 (D208.5),
FI-01530 Vantaa, Finland
Phone: +358-20-741-8100

• Denmark

Anritsu A/S
c/o Regus Winghouse, Ørestads Boulevard 73, 4th
floor,
2300 Copenhagen S, Denmark
Phone: +45-7211-2200

• Russia

Anritsu EMEA Ltd.
Representation Office in Russia
Tverskaya str. 16/2, bld. 1, 7th floor,
Moscow 125009, Russia
Phone: +7-495-363-1694
Fax: +7-495-935-8962

• Spain

Anritsu EMEA Ltd.
Representation Office in Spain
Paseo de la Castellana, 141.
Planta 5, Edificio Cuzco IV
28046, Madrid, Spain
Phone: +34-91-572-6761

• Austria

Anritsu EMEA GmbH
Am Belvedere 10, A-1100 Vienna, Austria
Phone: +43-(0)1-717-28-710

• United Arab Emirates

Anritsu EMEA Ltd.
Anritsu A/S
Office No. 164, Building 17, Dubai Internet City
P. O. Box - 501901, Dubai, United Arab Emirates
Phone: +971-4-3758479

• India

Anritsu India Private Limited
6th Floor, Indiqube ETA, No.38/4, Adjacent to EMC2,
Doddanekundi, Outer Ring Road,
Bengaluru - 560048, India
Phone: +91-80-6728-1300
Fax: +91-80-6728-1301

• Singapore

Anritsu Pte. Ltd.
11 Chang Charn Road, #04-01, Shriro House
Singapore 159640
Phone: +65-6282-2400
Fax: +65-6282-2533

• Vietnam

Anritsu Company Limited
16th Floor, Peakview Tower, 36 Hoang Cau Street,
O Cho Dua Ward, Dong Da District, Hanoi, Vietnam
Phone: +84-24-3201-2730

• P.R. China (Shanghai)

Anritsu (China) Co., Ltd.
Room 2701-2705, Tower A, New Caohejing
International Business Center No. 391 Gui Ping Road
Shanghai, 200233, P.R. China
Phone: +86-21-6237-0898
Fax: +86-21-6237-0899

• P.R. China (Hong Kong)

Anritsu Company Ltd.
Unit 1006-7, 10/F., Greenfield Tower, Concordia Plaza,
No. 1 Science Museum Road, Tsim Sha Tsui East,
Kowloon, Hong Kong, P.R. China
Phone: +852-2301-4980
Fax: +852-2301-3545

• Japan

Anritsu Corporation
8-5, Tamura-cho, Atsugi-shi, Kanagawa, 243-0016
Japan
Phone: +81-46-296-6509
Fax: +81-46-225-8352

• South Korea

Anritsu Corporation, Ltd.
5FL, 235 Pangyoeyeok-ro, Bundang-gu, Seongnam-si,
Gyeonggi-do 13494, South Korea
Phone: +82-31-696-7750
Fax: +82-31-696-7751

• Australia

Anritsu Pty. Ltd.
Unit 20, 21-35 Ricketts Road,
Mount Waverley, Victoria 3149, Australia
Phone: +61-3-9558-8177
Fax: +61-3-9558-8255

• Taiwan

Anritsu Company Inc.
7F, No. 316, Sec. 1, NeiHu Rd., Taipei 114, Taiwan
Phone: +886-2-8751-1816
Fax: +886-2-8751-1817

List Revision Date: 20210610