

Measurement Guide

Cable and Antenna Analyzer

for Anritsu's RF and Microwave Handheld Instruments

BTS Master™

The Anritsu logo is displayed in a blue, sans-serif font. The letter 'A' is stylized with a diagonal slash through it.

Unauthorized Use or Disclosure

Anritsu Company has prepared the product user documentation for use by Anritsu Company personnel and customers as a guide for the proper installation, operation, and maintenance of Anritsu Company equipment and software programs. The drawings, specifications, and information contained therein are the property of Anritsu Company, and any unauthorized use is prohibited; they shall not be reproduced, copied, or used in whole or in part as the basis for manufacture or sale of the equipment or software programs without the prior written consent of Anritsu Company.

Export Management

The Anritsu products identified herein and their respective manuals may require an Export License or approval by the government of the product country of origin for re-export from your country. Before you export these products or any of their manuals, please contact Anritsu Company to confirm whether or not these items are export-controlled. When disposing of export-controlled items, the products and manuals must be broken or shredded to such a degree that they cannot be unlawfully used for military purposes.

Updates

Updates, if any, can be downloaded from the Anritsu website at:

<http://www.anritsu.com/>

For the latest service and sales contact information in your area, please visit:

<http://www.anritsu.com/contact-us>

Table of Contents

Chapter 1—General Information

| | | |
|-----|---|-----|
| 1-1 | Introduction | 1-1 |
| 1-2 | Product Information, Compliance, and Safety | 1-1 |
| 1-3 | Contacting Anritsu | 1-1 |
| 1-4 | General Measurement Setups | 1-1 |
| 1-5 | Selecting the Cable and Antenna Mode | 1-2 |

Chapter 2—Cable and Antenna Analyzer

| | | |
|------|---|------|
| 2-1 | Overview | 2-1 |
| 2-2 | Cable and Antenna Measurement Setup | 2-1 |
| | Select Measurement Type | 2-1 |
| | Calibration | 2-1 |
| | Frequency | 2-2 |
| | Frequency/Distance | 2-2 |
| | Amplitude | 2-3 |
| | Sweep/Setup | 2-3 |
| | Limit Lines | 2-6 |
| | Markers | 2-8 |
| 2-3 | Using Trace Math | 2-10 |
| 2-4 | Return Loss/VSWR | 2-12 |
| 2-5 | Cable Loss | 2-14 |
| 2-6 | Distance-to-Fault (DTF) | 2-15 |
| | DTF Measurement | 2-17 |
| 2-7 | 2-Port Gain Measurements | 2-20 |
| | Example | 2-20 |
| 2-8 | Phase Measurements | 2-22 |
| | 1-Port Phase Measurement | 2-22 |
| | 2-Port Phase Measurement | 2-23 |
| 2-9 | Smith Chart | 2-24 |
| | Smith Chart Measurement | 2-24 |
| 2-10 | Cable and Antenna Analyzer Menus | 2-25 |
| 2-11 | Freq/Dist Menu | 2-27 |
| | Signal Standard Menu | 2-28 |
| 2-12 | Freq/Dist Menu | 2-29 |
| | DTF Setup Menu | 2-30 |
| 2-13 | Amplitude Menu | 2-31 |

Table of Contents (Continued)

| | | |
|------|----------------------------|------|
| 2-14 | Sweep/Setup Menu | 2-32 |
| 2-15 | Measurement Menu | 2-33 |
| 2-16 | Marker Menu | 2-34 |
| 2-17 | Sweep Menu | 2-35 |
| 2-18 | Measure Menu | 2-35 |
| 2-19 | Trace Menu | 2-35 |
| 2-20 | Limit Menu | 2-36 |
| | Limit Edit Menu | 2-37 |
| 2-21 | Other Menus | 2-38 |

Chapter 3—Calibration

| | | |
|-----|--|-----|
| 3-1 | Calibration | 3-1 |
| | 1-Port Calibration Procedure (OSL) | 3-1 |
| | 2-Port Calibration Procedure (OSLIT) | 3-3 |
| 3-2 | Calibration Menu | 3-4 |

Appendix A—Windowing

| | | |
|-----|---------------------------------------|-----|
| A-1 | Introduction | A-1 |
| A-2 | Examples | A-1 |
| | Rectangular Windowing | A-2 |
| | Nominal Side Lobe Windowing | A-3 |
| | Low Side Lobe Windowing | A-4 |
| | Minimum Side Lobe Windowing | A-5 |

Appendix B—Tower Mounted Amplifiers

| | | |
|-----|------------------------|-----|
| B-1 | Introduction | B-1 |
|-----|------------------------|-----|

Index

Chapter 1 — General Information

1-1 Introduction

The BTS Master model of instruments offers a wide range of display options for 1-port and 1-path 2-port vector corrected measurements.

Cable and antenna analyzer measurements include: VSWR, Return Loss, Cable Loss, Distance-To-Fault (DTF) Return Loss, DTF VSWR, 2-Port Gain, Smith Chart, 1-Port Phase, and 2-Port Phase.

1-2 Product Information, Compliance, and Safety

Read the Handheld Instruments Product Information, Compliance, and Safety Guide (PN: 10100-00065) for important safety, legal, and regulatory notices before operating the equipment. For additional information and literature covering your product, visit the product page of your instrument on <http://www.anritsu.com/> and select the Library tab.

Not all instrument models offer every option. Please refer to the Technical Data Sheet of your instrument for available options.

1-3 Contacting Anritsu

To contact Anritsu, please visit:

<http://www.anritsu.com/contact.asp>

From here, you can select the latest sales, select service and support contact information in your country or region, provide online feedback, complete a “Talk to Anritsu” form to have your questions answered, or obtain other services offered by Anritsu.

Updated product information can be found on the Anritsu web site:

<http://www.anritsu.com/>

Search for the product model number. The latest documentation is on the product page under the Library tab.

1-4 General Measurement Setups

The User Guide for the instrument provides a general overview of file management, system settings, and GPS. [Chapter 2](#) of this guide provides specific setup, measurement, and menu information for cable and antenna measurements. Measurement calibration is discussed in [Chapter 3](#).

1-5 Selecting the Cable and Antenna Mode

Select a measurement mode by pressing **Shift** and then the **Mode** (9) button to open the Mode Selector dialog box. Highlight the Cable & Antenna Analyzer measurement mode using the **Up** or **Down** arrow keys and press **Enter**.

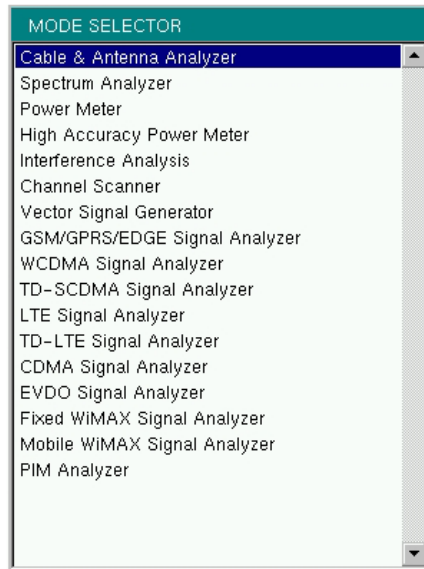

Figure 1-1. Mode Selector Dialog Box

Note

Screen captured images are provided as examples. The image and measurement details shown on your instrument may differ from the examples in this measurement guide.

The actual menus on your instrument may also differ based on instrument model, firmware version, and installed options.

Some Anritsu handheld instruments also have a **Menu** button which displays icons of installed measurement modes and allows measurement mode selection using the touch screen.

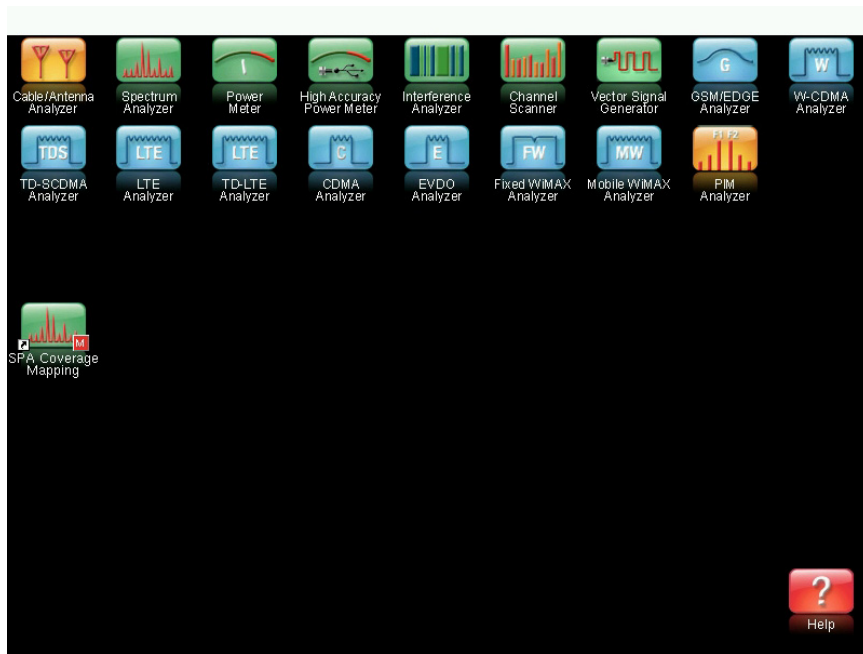

Figure 1-2. Mode Selector Dialog Box

Chapter 2 — Cable and Antenna Analyzer

2-1 Overview

This chapter shows how to setup the instrument and perform basic line sweep measurements.

| | |
|-------------|--|
| Note | Confirm that the instrument is in Cable & Antenna Analyzer mode. Refer to Section 1-4 “General Measurement Setups” on page 1-1 . |
|-------------|--|

For accurate results, the instrument must be calibrated before making any measurements. The instrument must be re-calibrated whenever the temperature exceeds the calibration temperature range or when the test port extension cable is removed or replaced. Unless the calibration type is FlexCal, the instrument must also be re-calibrated every time the setup frequency changes. See [Chapter 3, “Calibration”](#) for details on how to perform a calibration.

2-2 Cable and Antenna Measurement Setup

This section covers the following measurement setups functions:

- [“Select Measurement Type” on page 2-1](#)
- [“Calibration” on page 2-1](#)
- [“Frequency” on page 2-2](#)
- [“Amplitude” on page 2-3](#)
- [“Sweep/Setup” on page 2-3](#)
- [“Limit Lines” on page 2-6](#)
- [“Markers” on page 2-8](#)

Select Measurement Type

Press the **Measurement** main menu key and select the appropriate measurement. The setup instructions below apply to all cable & antenna measurements. For specific instructions on how to setup Distance-To-Fault, refer to [“Distance-to-Fault \(DTF\)” on page 2-15](#).

Calibration

For accurate results, the instrument must be calibrated before making any measurements. The instrument must be re-calibrated whenever the temperature exceeds the calibration temperature range or when the test port extension cable is removed or replaced. Unless the calibration type is FlexCal, the instrument must also be re-calibrated every time the setup frequency changes. See [Chapter 3, “Calibration”](#) for details on how to perform a calibration.

Frequency

For VSWR, Return Loss, Cable Loss, 2-Port Gain, Smith Chart, 1-Port Phase, and 2-Port Phase measurements.

Setting up the Measurement Frequency using Start and Stop Frequencies

1. Press the **Freq/Dist** main menu key.
2. Press the **Start Freq** submenu key and use the keypad to enter the start frequency. When entering a frequency using the keypad, the key labels change to GHz, MHz, kHz, and Hz. Press the appropriate unit key to complete the entry.
3. Press **Stop Freq** and use the keypad to enter the stop frequency. Press the appropriate unit key to complete the entry.

Setting up the Measurement Frequency by Selecting a Signal Standard

1. Press the **Freq/Dist** main menu key.
2. Press the **Signal Standard** submenu key.
3. Select uplink, downlink, or uplink plus downlink.
4. Press the **Select Standard** key.
5. Use the rotary knob or the **Up/Down** arrow keys and scroll to the appropriate signal standard and press **Enter** to select.

| | |
|-------------|--|
| Note | The Signal Standard menu can be customized. If a particular standard is missing, Line Sweep Tools (LST) can be used to edit the signal standard list. Please refer to the LST Help menu for details. |
|-------------|--|

Frequency/Distance

(Distance-To-Fault Return Loss, Distance-To-Fault VSWR)

1. Press the **Freq/Dist** main menu key.
2. Press the **Units** key to toggle between using meter (m) or feet (ft).
3. Press the **Start Dist** submenu key and use the arrow keys, rotary knob, or keypad to enter the start distance. When entering a distance using the keypad, press the unit key or **Enter** to complete the entry.

| | |
|-------------|--|
| Note | The Start Dist cannot be set beyond the Stop Dist. |
|-------------|--|

4. Press **Stop Dist** and enter the stop distance.
5. To set the frequency, press **DTF Aid**. For more details about DTF Aid, refer to [“DTF Measurement” on page 2-17](#).

Refer to [“Freq/Dist Menu” on page 2-27](#) for additional information.

Amplitude

For Amplitude in Smith Chart measurements, see [“Smith Chart” on page 2-24](#).

Setting the Amplitude using Top and Bottom Keys

1. Press the **Amplitude** main menu key.
2. Press the **Top** submenu key and use the keypad, rotary knob, or the **Up/Down** arrow key to edit the top scale value. Press **Enter** to set.
3. Press the **Bottom** key and use the keypad, rotary knob, or the **Up/Down** arrow key to edit the bottom scale value. Press **Enter** to set.

Setting the Amplitude using Autoscale

The instrument will automatically set the top and bottom scales to the minimum and maximum values of the measurement with some margin on the y-axis of the display.

1. Press the **Amplitude** main menu key
2. Press the **Autoscale** submenu key

Setting the Amplitude using Fullscale

To automatically set the scale to the default setting (0 dB to 60 dB for Return Loss and 1 to 65.535 for VSWR), press the **Fullscale** key. The instrument will automatically set the top and bottom scales to the default values.

1. Press the **Amplitude** main menu key.
2. Press the **Fullscale** submenu key.

Refer to [“Amplitude Menu” on page 2-31](#) for additional information.

Sweep/Setup

The sweep/setup menus include keys to set Run/Hold, Sweep Type, RF Immunity, Data Points, Averaging and Smoothing, and Output power.

Run/Hold

Controls if the instrument is actively sweeping the frequency range. When Sweep Type is set to **Single**, this key also provides a single sweep trigger.

1. Press the **Sweep (3)** main menu key.
2. Toggle the Run/Hold key.

Sweep Type Single and Continuous

This key toggles the sweep between **Single** and **Continuous** sweep. In single sweep mode, each sweep must be activated by the Run/Hold key.

1. Press the **Sweep (3)** main menu key.
2. Toggle the Sweep Type key.

RF Immunity High / Low

The instrument defaults to RF Immunity High. This setting protects the instrument from stray signals from nearby or co-located transmitters that can affect frequency and DTF measurements. The algorithm used to improve the instrument's ability to reject unwanted signals slows down the sweep speed. If the instrument is used in an environment where immunity is not as issue, the RF Immunity key can be set to Low to optimize sweep speed. Use this feature with caution, as the introduction of an interfering signal might be mistaken for a problem with the antenna or cable run. If Immunity is set to Low during a normal RL or VSWR measurement, the instrument will be more susceptible to interfering signals. Interfering signals can make the measurement look better or worse than it really is.

1. Press the **Sweep (3)** main menu key.
2. Toggle the RF Immunity key.

Data Points

The number of data points can be set to 137, 275, or 551 data points. This can be changed before or after calibration regardless of the display setting. The default setting is 275. This is recommended for most measurements. Additional data points slow down the sweep speed but are helpful in DTF, as they enable increased distance coverage for the same distance resolution.

1. Press the **Sweep (3)** main menu key.
2. Press the Data Points key to select 137, 275, or 551 data points.

Refer to “[Sweep/Setup Menu](#)” on [page 2-32](#) for additional information.

Averaging

Averaging helps to average out the trace and minimize the effect of outliers. Trace averaging takes the running average of the number of traces indicated in the Averaging Factor. The Average Count in the status window turns when Averaging is turned on. When the Average Count reaches the entered average count, a running average of the last set of sweeps is performed. Averaging Factor can be set between 1 and 65535.

1. Press the **Sweep (3)** main menu key.
2. Press the Averaging Smoothing submenu key.
3. Press Averaging Factor and enter the number of running averages using the arrow keys, rotary knob, or keypad and then press the **Enter** key.
4. Press the Averaging On/Off key and toggle Averaging to On.
5. Press the Restart key to start the averaging sequence from the beginning.

Smoothing %

Smoothing is a mathematical function that calculates a rolling average of the trace data. This provides a way to look at the general shape of a measurement while smoothing out smaller variations. The value is the amount of the display that is incorporated into the rolling average. Valid entries range from 0% (no smoothing) to 10% (maximum smoothing).

The display in [Figure 2-1](#) illustrates how smoothing can be used to reduce ripples when making 1-port cable loss measurements. The white trace shows the trace with no smoothing and the yellow trace shows the trace with 7% smoothing.

1. Press the **Sweep (3)** main menu key.
2. Press the Averaging Smoothing submenu key.
3. Select the Smoothing % key and enter the level of smoothing (1% to 10%).

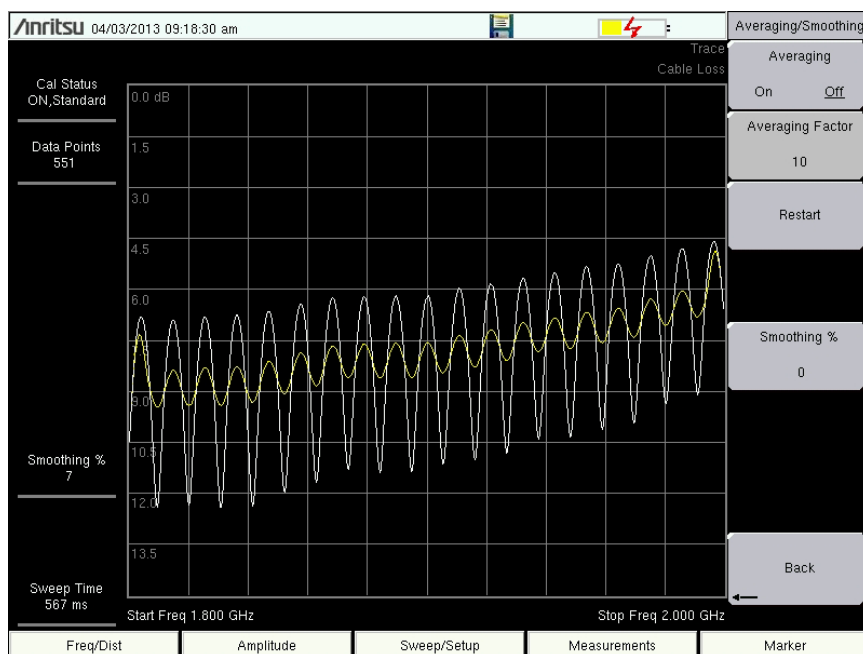

Figure 2-1. Smoothing Reduces Ripple

Output Power (Low/High)

The power level defaults to High for all 1-port measurements (~ -7 dBm). It can be changed to Low (~ -40 dBm) if needed. All line sweep 1-port measurements should be performed with the output power High setting.

1. Press the **Sweep (3)** main menu key.
2. Select the Output Power submenu key and toggle Output Power between High and Low.

Refer to [“Sweep/Setup Menu” on page 2-32](#) for additional information.

Limit Lines

To access the functions under the Limit menu, press the **Shift** key, then the **Limit (6)** key.

Limit lines can be used for visual reference only, or for pass/fail criteria using the limit alarm. Limit alarm failures are reported whenever a signal crosses a limit line.

Limit line can consist of a single segment or as many as 40 segments across the entire frequency span of the instrument. These limit segments are retained regardless of the current frequency span of the instrument, allowing the configuring of specific limit envelopes at various frequencies of interest without having to re-configure them each time the frequency is changed. To clear the current limit setup configuration and return to a single limit segment starting at the current start frequency and ending at the current stop frequency, press the **Clear Limit** submenu key.

The **Limit On/Off** submenu key turns the currently limit line on or off.

The **Multi-Segment Edit** submenu key displays a submenu that allows the creation or editing of single or multi-segment limit lines. The currently active limit point is marked by a red circle on the display.

The **Limit Alarm** submenu key enables the alarm to beep when a data point exceeds the limit.

The **Clear Limit** submenu key deletes all limit points for the currently active limit line and defaults to a single limit with an amplitude value selected to make it visible on the screen.

Single Limit Line (Figure 2-2 on page 2-7)

1. Press **Shift** and then **Limit (6)** to display the Limit menu.
2. Press the **Limit On/Off** key to turn on the Limit.
3. Press **Single Limit** and then use the arrow keys, rotary knob, or numeric keypad to change the limit value. Press **Enter** to complete.
4. Press the **Limit Alarm** key to turn on or off the Limit Alarm.

Segmented Limit Line

1. Press **Shift** and then **Limit (6)** to enter the Limit menu.
2. Press the **Limit On/Off** key to turn on the Limit.
3. Press the **Multi-Segment Edit** key. The default limit line has two points. Add points as needed. The limit line example shown in [Figure 2-3 on page 2-7](#) has 3 segments requiring 6 points.
4. The selected point is highlighted in red. Once selected, a point can be moved left or right using the **Point Freq (Distance for DTF measurements)** key and up or down using the **Point Value** key.

Adjusting the Volume of Limit Alarm

1. Press **Shift** and then **System (8)**
2. Press the **System Options** submenu key.
3. Press the **Volume** key.
4. Use the **Up/Down** arrow keys or rotary knob to adjust the volume. Press **Enter** to complete.

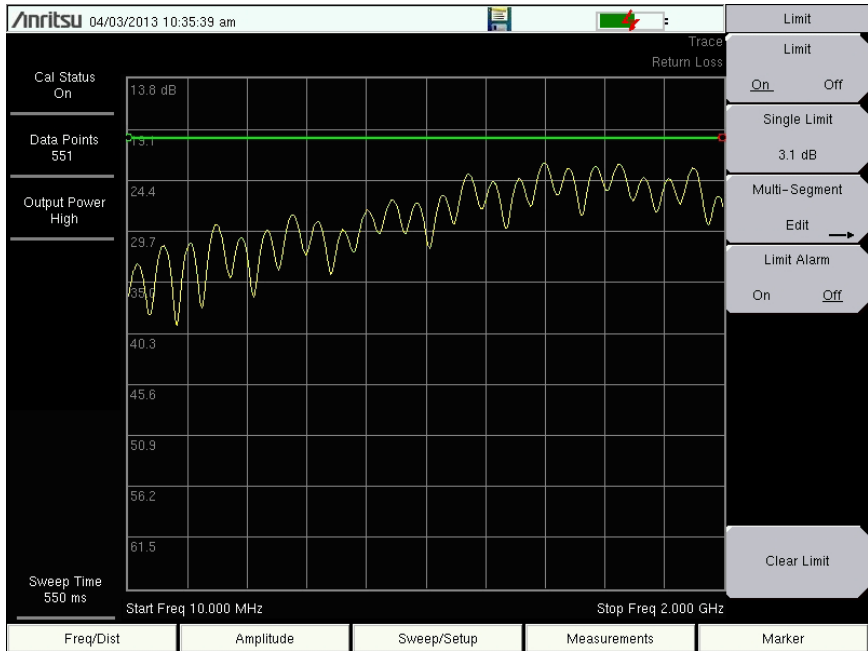

Figure 2-2. Single Limit Lines

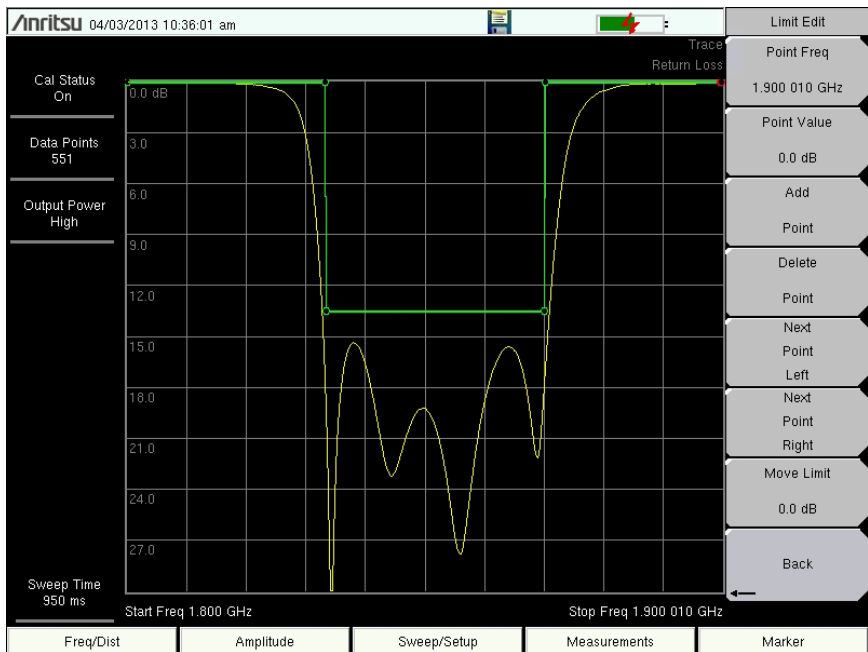

Figure 2-3. Segmented Limit Lines

Markers

Pressing the **Marker** function hard key below the display will bring up the Marker menu.

Press the **Marker** submenu key to select a marker. The underlined number indicates the active marker. The **On/Off** submenu key turns the selected marker On or Off. Use the arrow keys, the keypad or the rotary knob to move the marker. The current value for the selected marker is shown above the upper left corner of the graph.

The **Delta** submenu key is available for each marker giving a total of 6 Delta markers. The **Marker Table** submenu key displays a table of up to six Markers and 6 Delta Markers simultaneously, showing frequency and amplitude respectively ([Figure 2-4](#)).

The **Marker to Peak** submenu key moves the currently selected marker to the peak of the trace. The **Marker to Valley** submenu key moves the currently selected marker to the valley of the trace.

Markers can be stored in the setups and recalled with the setup file at a later time.

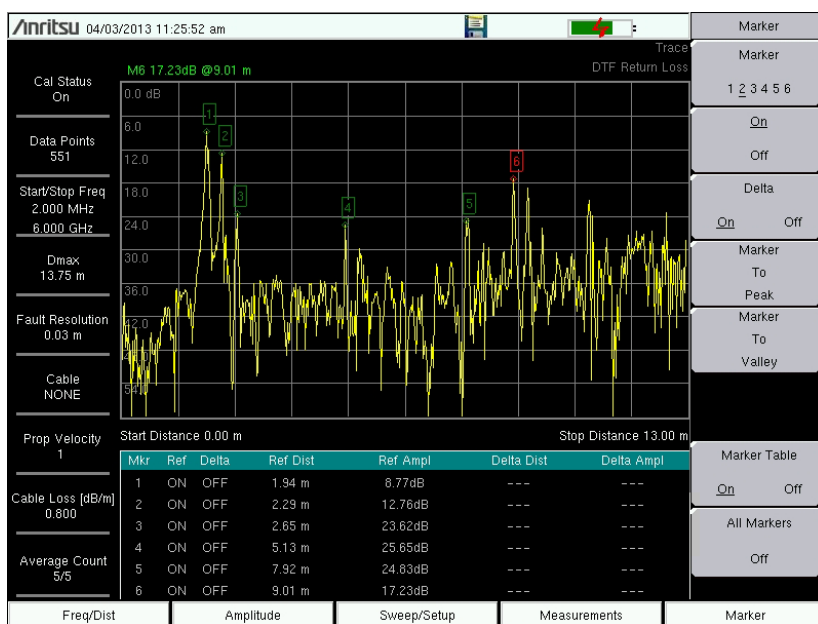

Figure 2-4. Marker Table

Select, Activate, and Place a Marker / Delta Marker

Markers can be applied to active or recalled measurements. The instrument supports six reference and six delta markers.

1. Press the **Marker** main menu key.
2. Press the **Marker** 1 2 3 4 5 6 key to select Marker number 1. The underlined number indicates the active marker.
3. Use the arrow keys, the keypad, or the rotary knob to move the marker. The current value for the selected marker is shown above the upper-left corner of the graph.
4. The Delta Markers are available for each of the six reference markers. For the selected marker, **Toggle Delta** so that On is underlined to activate the Delta marker.

Marker To Peak and Marker To Valley

All the cable & antenna measurements include Marker To Peak and Marker To Valley selections that sets the peak and valley markers automatically.

1. Press the **Marker** main menu key.
2. Toggle the On/Off key to activate a marker.
3. Press Marker To Peak to set the marker to the peak of the measurement.
4. Press Marker To Valley to set the marker to valley of the measurement.

Peak Between M1 and M2 and Valley Between M1 and M2

When Marker 5 is selected, pressing the Marker Options key will bring up two more options.

1. Press the **Marker** main menu key.
2. Select Marker 5.
3. Press Marker Options and select Peak between M1 & M2 or Valley Between M1&M2.

Peak Between M3 and M4 and Valley Between M3 and M4

When Marker 6 is selected, pressing the Marker Options key will bring up two more options.

1. Press the **Marker** main menu key.
2. Select Marker 6.
3. Press Marker Options and select Peak Between M3 & M4 or Valley Between M3 & M4.

Marker Table

The Marker Table allows for viewing of up to six reference markers and six delta markers.

1. Press the **Marker** main menu key.
2. Press the Marker Table On/Off key.

Refer to [“Marker Menu” on page 2-34](#) for additional information.

2-3 Using Trace Math

Trace Math menu is an excellent tool for comparing two traces. It is possible to upload traces using Line Sweep Tools, store those traces in memory, and compare the stored trace with a more recent trace. It is also possible to use the trace math features to normalize the trace and obtain a reference for S21 measurements where a full 2-port calibration is not needed. The trace math menu can be used to add or subtract logarithmic data (multiply and divide linear data).

Access the Trace Math menu by pressing the **Shift** key and the **Trace (5)** key.

Example 1

Comparing the Return Loss data for two five meter cables, Cable A and Cable B (Figure 2-5).

1. Press the **Measurement** main menu key and press the Return Loss submenu key.
2. Connect Cable B to the BTS Master RF Out port.
3. Press the **Shift** key and the **Trace (5)** key.
4. Press the Copy Trace To Display Memory submenu key.
5. Connect Cable A to the BTS Master RF Out port and perform the same Return Loss measurement over the same frequency range.
6. Turn Trace Overlay submenu key On to view the Return Loss measurement of Trace B.
7. Press the Trace + Memory submenu key to view the Return Loss measurement of Trace A and Trace B at the same time.
8. Press the Trace - Memory submenu key to look at the difference in Return Loss between the two cables.

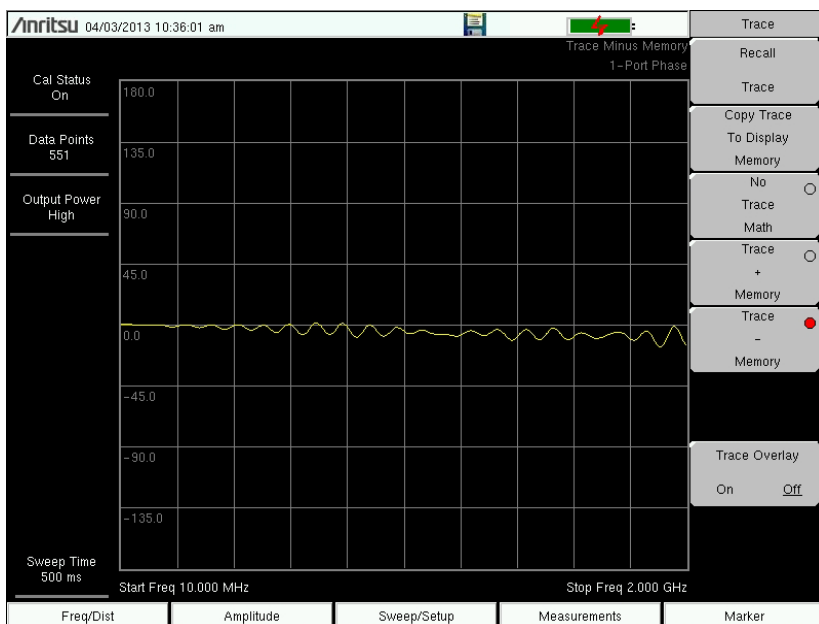

Figure 2-5. Trace Menu Showing Trace – Memory

Example 2

Using the Trace Menu to normalize a trace for Transmission measurement. Please note that normalizing the trace will not give the same accuracy as a calibrated 2-port measurement.

Note The instrument incorporates internal gain stages that can negatively affect measurement accuracy if used uncalibrated. This effect can be exaggerated when using trace math to compare measurements with different gains.

1. Connect a through-cable between Ports 1 and 2 for the normalization procedure.
1. Press the **Measurement** main menu key. Press the 2-Port Gain submenu key.
2. Under the **Freq/Dist** main menu key, use the **Start Freq** and **Stop Freq** submenu keys to set the Start and Stop frequencies.
3. Press the **Shift** key and the **Trace** (5) key.
4. Press the Copy Trace To Display Memory submenu key.
5. Press the Trace - Memory submenu key to see the trace normalized around 0 dB (Figure 2-6).

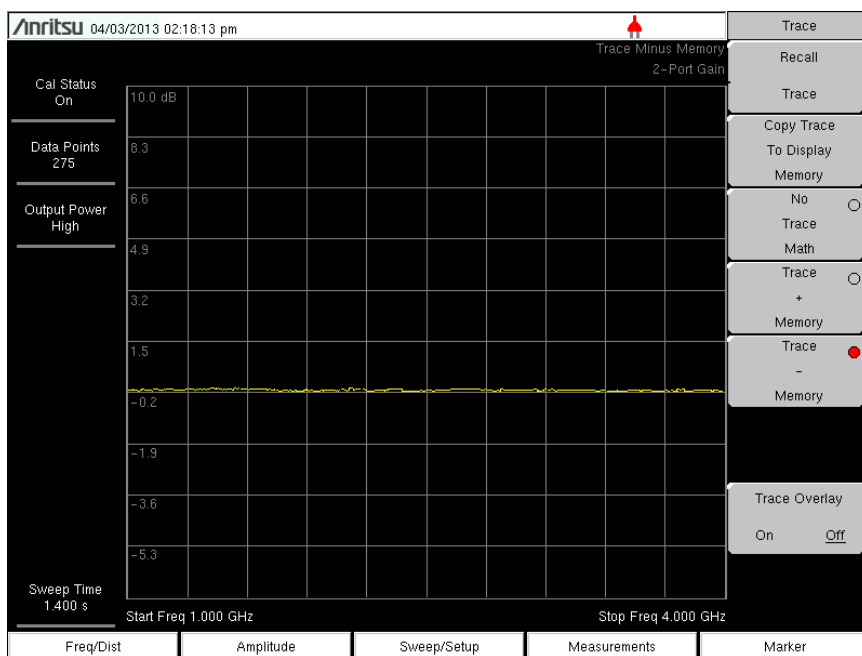

Figure 2-6. Normalizing the Trace Using Trace Math

2-4 Return Loss/VSWR

Return Loss is used to characterize RF components and systems. The Return Loss indicates how well the system is matched by taking the ratio of the reflected signal to the incident signal, measuring the reflected power in dB. The 1-port Measurement data can also be displayed linearly as VSWR, or by using Line Sweep Tools, display the reflection coefficient.

Procedure

1. If a test port extension cable is to be used, connect it to the RF Out connector.
2. Press the **Measurement** main menu key and press the Return Loss submenu key.
3. Under the **Freq/Dist** main menu key, use the Start Freq and Stop Freq submenu keys to set the Start and Stop frequencies. Or enter a known signal standard by pressing Signal Standard submenu key followed by Select Standard (Figure 2-7).

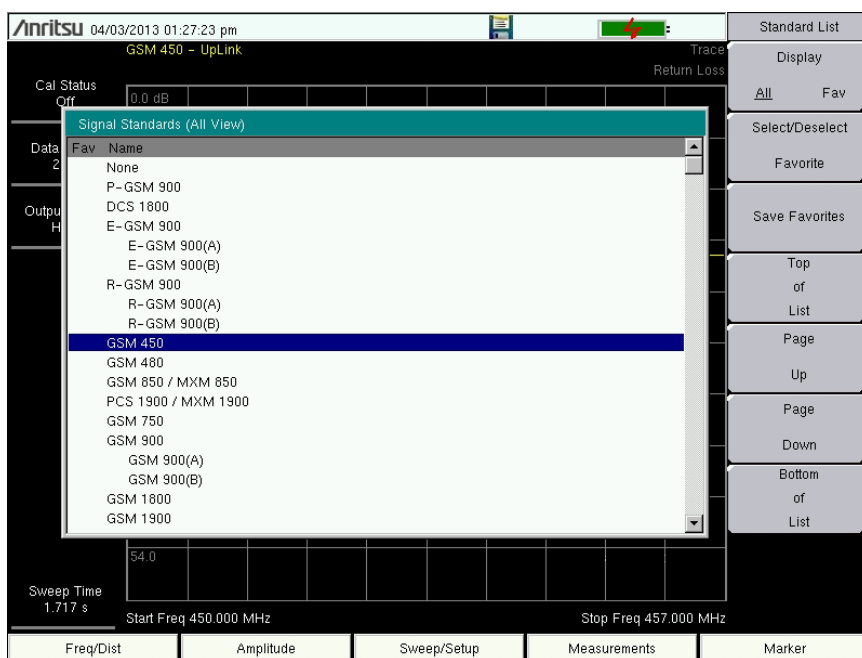

Figure 2-7. Signal Standards

4. Press the Start Cal key to perform a 1-port OSL calibration at the connector or at end of the extension cable. When the Calibration is finished, Cal Status On should be displayed in the upper left part of the display and the trace should be centered around 0 dB when the short or open is connected.
5. Connect the test port extension cable to the Device Under Test (DUT).
6. Refer to the Users Guide for saving trace measurements.
7. Press the **Measurement** main menu key and press the VSWR submenu key to view the match in VSWR.

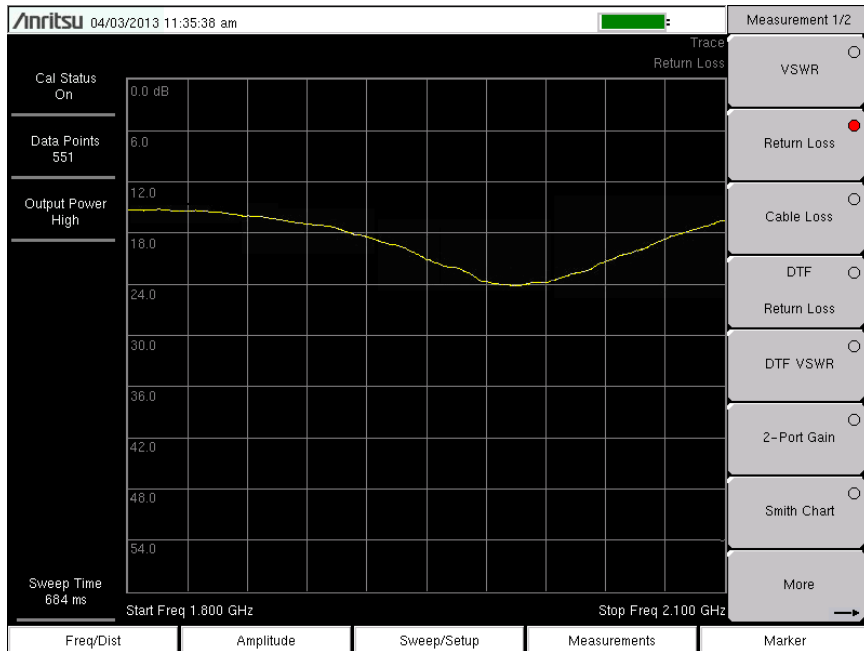

Figure 2-8. Return Loss of an Antenna

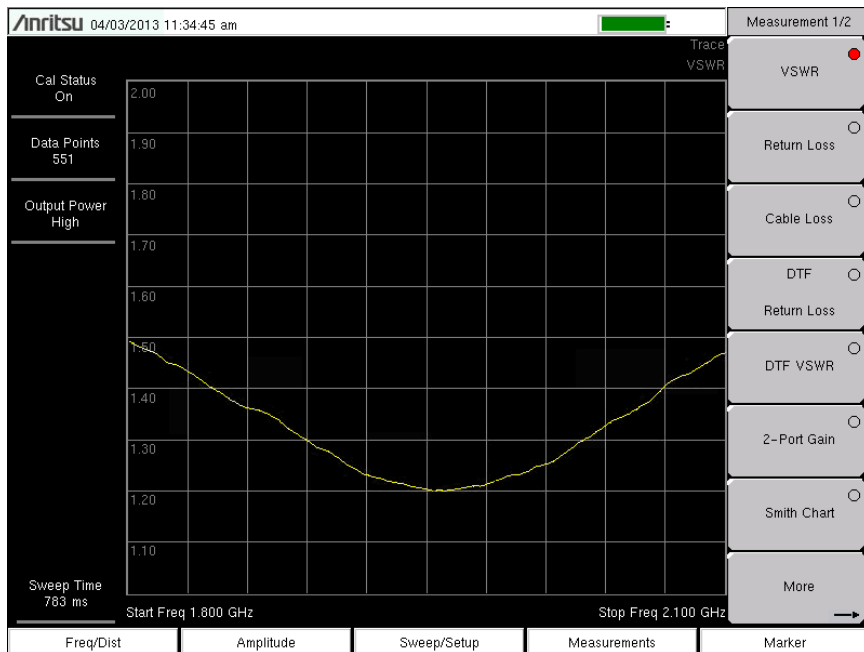

Figure 2-9. VSWR of an Antenna

2-5 Cable Loss

The cable loss test verifies the signal attenuation level of the cable. This test can be done using the Cable Loss or Return Loss Measurement with a short or an open connected at the end of the system. The advantage of using the Cable Loss measurement is that there is no need to compute the results. Cable Loss is a Return Loss measurement, but it also takes into consideration that the signal travels in both directions.

Procedure

1. If a test port extension cable is to be used, connect it to the RF Out connector on the BTS Master.
2. Press the **Measurement** main menu key and press the **Cable Loss** submenu key.
3. Press the **Freq/Dist** main menu key and set the Start Frequency and Stop Frequency.
4. Press the **Shift** key, then the **Calibrate** (2) key.
5. Press the **Cal Type** submenu key to set the calibration to 1-Port.
6. Press the **Start Cal** submenu key and perform a 1-port OSL calibration at the connector or at end of the extension cable. When the Calibration is finished, **Cal Status On** should be displayed in the upper left part of the display and the trace should be centered around 0 dB when the short or open is connected.
7. Connect the test port extension cable to the Feed Line.
8. Refer to the User Guide for saving the trace measurement. Note that average Cable Loss: (peak + valley) / 2 is displayed in the status window.

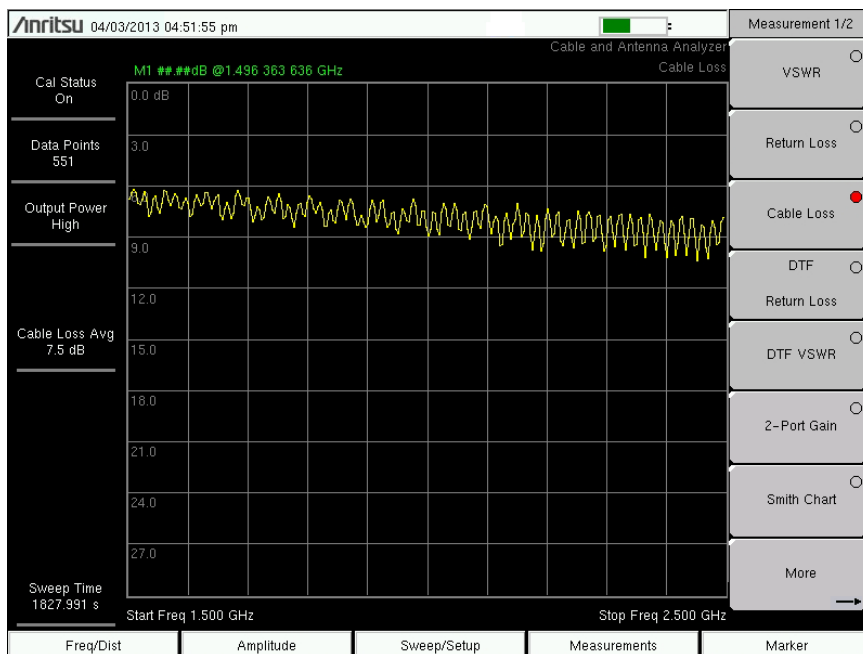

Figure 2-10. Cable Loss

2-6 Distance-to-Fault (DTF)

The DTF measurement displays return loss (or VSWR) values versus distance. If the frequency measurements fail or indicate a problem in the system, then the DTF measurement can be used to identify and pinpoint the exact location of the problem. The DTF measurement shows the return loss value of all the individual components including connector pairs and cable components.

To measure the distance of a cable, DTF measurements can be made with an open or a short connected at the end of the cable. The peak indicating the end of the cable should typically be between 0 dB and 5 dB.

An open or short should not be used when DTF is used for troubleshooting because the open/short will reflect all the signal and the true value of a connector might be misinterpreted and a good connector could look like a failing connector.

A 50 Ω load is the best termination for troubleshooting DTF problems because it will be 50 Ω over the entire frequency range. The antenna can also be used as a terminating device but the impedance of the antenna will change over different frequencies because most antennas are only designed to have 15 dB or better return loss in the passband of the antenna.

DTF measurement is a frequency domain measurement and the data is transformed to the time domain using mathematics. The distance information is obtained by analyzing how much the phase is changing when the system is swept in the frequency domain.

Frequency selective devices such as TMAs (Tower Mounted Amplifiers), duplexers, filters, and quarter wave lightning arrestors change the phase information (distance information) if they are not swept over the correct frequencies. Care needs to be taken when setting up the frequency range whenever a TMA is present in the path. [Appendix B](#) provides TMA details.

Because of the nature of the measurement, maximum distance range and fault resolution is dependent on the frequency range and number of data points. DTF Aid shows how the parameters are related. If the cable is longer than DMax, the only way to improve the horizontal range is to reduce the frequency span or to increase the number of data points. Similarly, the fault resolution is inversely proportional to the frequency range and the only way to improve the fault resolution is to widen the frequency span.

The BTS Master is equipped with a cable list ([Figure 2-11](#)) including most of the common cables used today. Once the correct cable has been selected, the measurement parameters will update the propagation velocity and the cable attenuation values to correspond with the cable. These values can also be entered manually. Custom Cable lists can also be created with Line Sweep Tools and uploaded into the instrument. Incorrect propagation velocity values will affect the distance accuracy and inaccurate cable attenuation values will affect the accuracy of the magnitude value.

| Cable Name | [Prop Vel | (F1 | CL1(dB/m) | (F2 | CL2(dB/m) | (F3 | CL3(dB/m) |] |
|--------------------|------------|--------|-----------|--------|-----------|--------|-----------|---|
| NONE | [0.100 | (1000 | , 0.080) | (1500 | , 0.080) | (2000 | , 0.080) |] |
| FSJ1-50A (6 GHz) | [0.84 | (1000 | , 0.020) | (2500 | , 0.032) | (6000 | , 0.053) |] |
| FSJ2-50 (6 GHz) | [0.83 | (1000 | , 0.013) | (2500 | , 0.022) | (6000 | , 0.037) |] |
| FSJ4-50B (6 GHz) | [0.81 | (1000 | , 0.012) | (2500 | , 0.020) | (6000 | , 0.034) |] |
| EFX2-50 (6 GHz) | [0.85 | (1000 | , 0.012) | (2500 | , 0.020) | (6000 | , 0.034) |] |
| LDF1-50 (6 GHz) | [0.86 | (1000 | , 0.014) | (2000 | , 0.020) | (6000 | , 0.038) |] |
| LDF2-50 (6 GHz) | [0.88 | (1000 | , 0.012) | (2000 | , 0.017) | (6000 | , 0.032) |] |
| LDF4-50A (6 GHz) | [0.86 | (1000 | , 0.007) | (2500 | , 0.012) | (6000 | , 0.020) |] |
| HJ4-50 (6 GHz) | [0.91.4 | (1000 | , 0.009) | (2500 | , 0.016) | (6000 | , 0.026) |] |
| HJ4.5-50 (6 GHz) | [0.92 | (1000 | , 0.005) | (2500 | , 0.009) | (6000 | , 0.015) |] |
| 310801_____ | [0.82.1 | (1000 | , 0.012) | (1000 | , 0.012) | (1000 | , 0.012) |] |
| 311201_____ | [0.82 | (1000 | , 0.018) | (1000 | , 0.018) | (1000 | , 0.018) |] |
| 311501_____ | [0.80 | (1000 | , 0.023) | (1000 | , 0.023) | (1000 | , 0.023) |] |
| 311601_____ | [0.80 | (1000 | , 0.026) | (1000 | , 0.026) | (1000 | , 0.026) |] |
| 311901_____ | [0.80 | (1000 | , 0.038) | (1000 | , 0.038) | (1000 | , 0.038) |] |
| 352001_____ | [0.80 | (1000 | , 0.038) | (1000 | , 0.038) | (1000 | , 0.038) |] |
| AVA5-50 7/8_____ | [0.91 | (1000 | , 0.004) | (2000 | , 0.005) | (2500 | , 0.006) |] |
| AVA7-50 1-5/8_____ | [0.92 | (1000 | , 0.002) | (2000 | , 0.003) | (2500 | , 0.004) |] |
| CR50 540PE_____ | [0.88 | (1000 | , 0.007) | (2000 | , 0.010) | (2500 | , 0.012) |] |
| CR50 1070PE_____ | [0.88 | (1000 | , 0.004) | (2000 | , 0.005) | (2500 | , 0.006) |] |

Figure 2-11. Cable List

Fault Resolution

Fault resolution is the system's ability to separate two closely spaced discontinuities. If the fault resolution is 10 feet and there are two faults 5 feet apart, the instrument will not be able to show both faults unless Fault Resolution is improved by widening the frequency span.

$$\text{Fault Resolution (m)} = 1.5 \times 10^8 \times \text{vp} / \Delta F$$

Where, vp is the cable propagation velocity and ΔF is frequency span.

DMax

DMax is the maximum horizontal distance that can be analyzed. The Stop Distance can not exceed Dmax. If the cable is longer than Dmax, Dmax needs to be improved by increasing the number of data points or lowering the frequency span (ΔF). Note that the data points can be set to 137, 275, or 551.

$$\text{Dmax} = (\text{Datapoints} - 1) \times \text{Fault Resolution}$$

Suggested Span

If the frequency span is set to the suggested span, the Stop Distance will equal Dmax giving the best fault resolution for the given conditions. With Stop Dist entered in meters, the following relationship can be obtained:

$$\text{Suggested Span (Hz)} = (\text{Datapoints} - 1) \times 1.5 \times 10^8 \times \text{vp} / \text{Stop Dist}$$

DTF Measurement

1. Press the **Measurements** main menu key and select DTF Return Loss or DTF VSWR.
2. Press the **Freq/Dist** main menu key.
3. Press the **Units** submenu key and select m to display distance in meters or ft to display distance in feet.
4. Press DTF Aid and use the touch screen, or arrow keys to navigate through all the DTF parameters.
 - a. Set Start Distance and Stop Distance. Stop Distance needs to be smaller than Dmax.

Note If Stop Distance is greater than DMax, increase the number of data points.

- b. Enter the Start and Stop frequencies.
 - c. Press **Cable** and select the appropriate cable from the cable list (Figure 2-11).
 - d. Press **Continue**.
5. Press **Shift** and **Calibrate** (2) to calibrate the instrument. See Chapter 3, “Calibration” for details.
6. Press the **Marker** main menu key and set the appropriate markers as described in “Markers” on page 2-8.
7. Press **Shift** and **Limit** (6) to enter and set the limits as described in “Limit Lines” on page 2-6.
8. Press **Shift** and **File** (7) to save the measurement. See the User Guide for details.

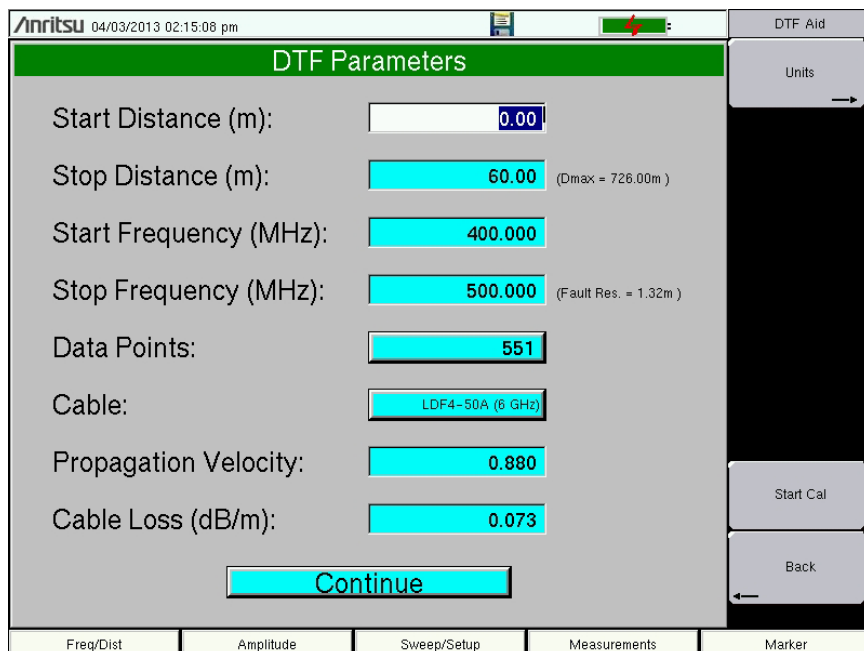

Figure 2-12. DTF Aid

Figure 2-13 shows a DTF measurement of a cable with a short at the end of the cable. This measurement is done to determine the length of the cable. The return loss value marking the end of the cable will typically be between 0 dB and 5 dB.

Figure 2-14 shows a DTF measurement of a good cable with a load. Figure 2-15 shows a DTF measurement of a cable with a fault.

Procedure

1. Press the **Measurement** main menu key and press DTF Return Loss.
2. Use the **Stop Dist** submenu key to enter the Stop Distance. Make sure that Stop Distance is smaller than Dmax.
3. Use the **Units** submenu key to select meters or feet.
4. To change the number of data points, press the **Sweep/Setup** main menu key then **Data Points** submenu key to select 137, 275, or 551 as the number of data points.
5. Press the **Shift** key, then the **Calibrate** (2) key.
6. Press the **Cal Type** submenu key to set the calibration to 1-Port.
7. Press the **Start Cal** submenu key and perform a 1-port OSL calibration at the connector or at end of the extension cable. When the Calibration is finished, **Cal Status On** should be displayed in the upper left part of the display, and the trace should be centered around 0 dB when the short or open is connected.
8. Press the **Marker** main menu key, then press the **Peak Search** submenu key.

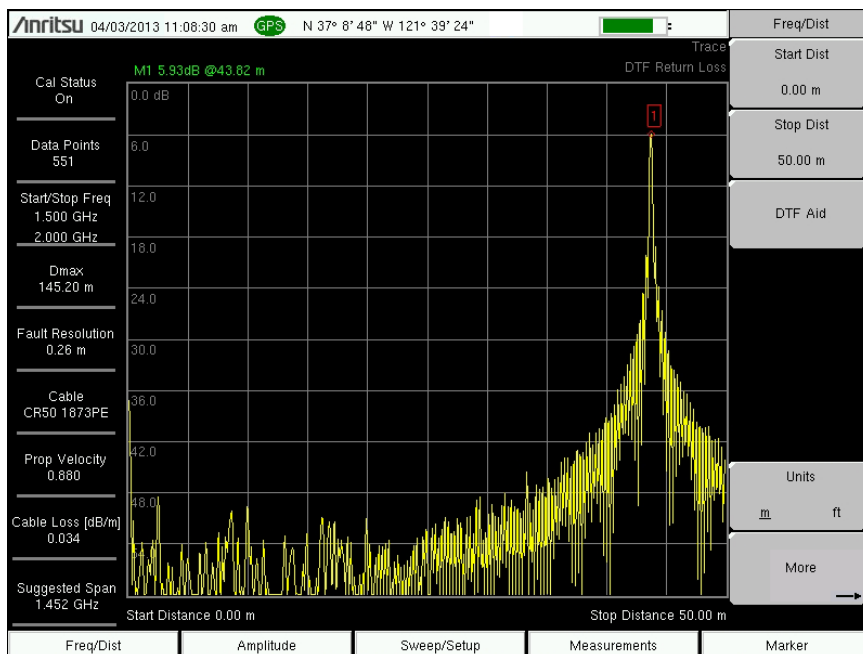

Figure 2-13. DTF with a Short at the End of the Cable

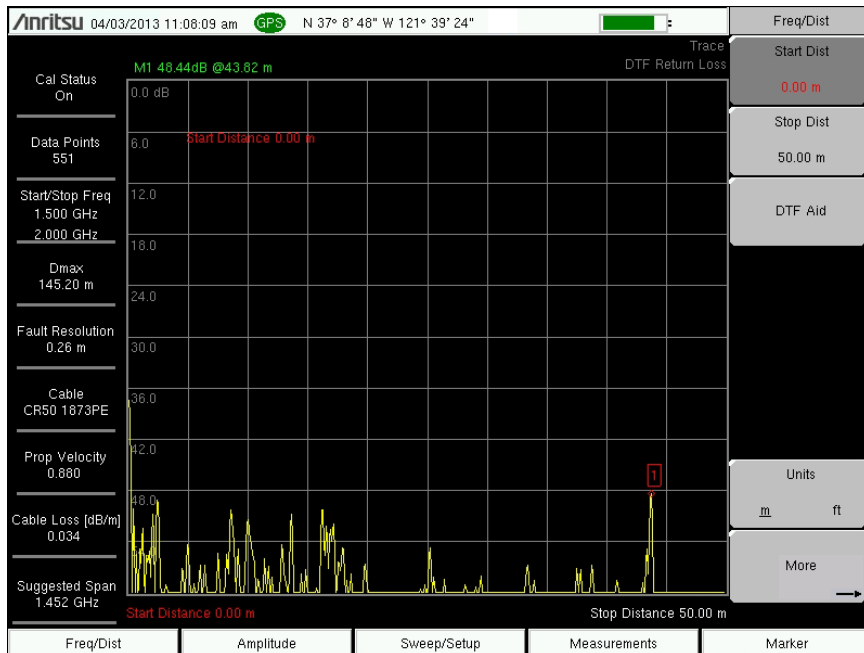

Figure 2-14. DTF of a Good Cable with a Load at the End of the Cable

Figure 2-15 shows an example of a fault at approximately 50 meters.

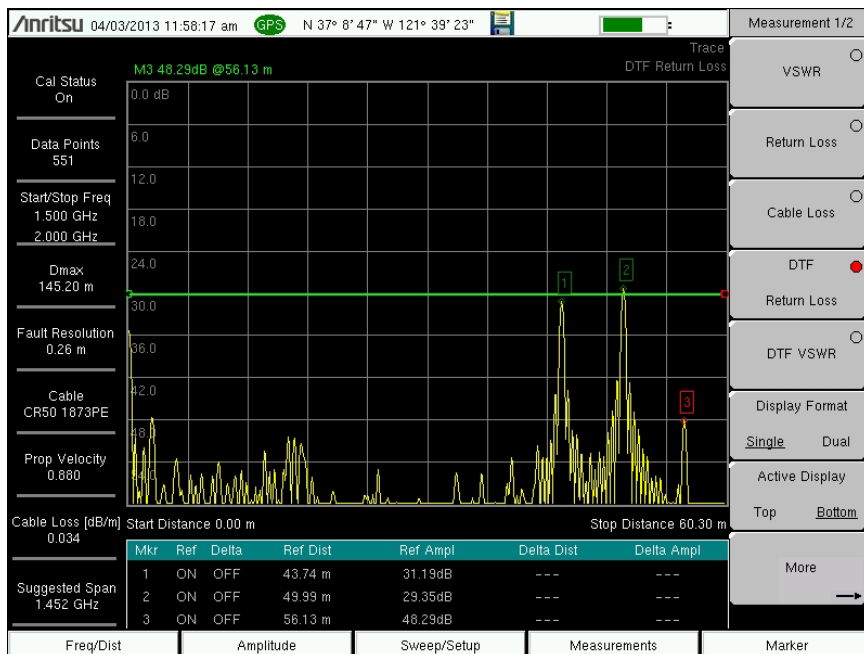

Figure 2-15. DTF with a Fault in the Cable and a Short at the End

2-7 2-Port Gain Measurements

There are two power levels available for 2-port measurements: High (approximately -7 dBm) and Low (approximately -40 dBm). The low power setting should be used when making direct gain measurements of amplifiers. This will ensure that the amplifier is operating in the linear region. The High power setting is ideal when characterizing passive devices but can also be used when making relative gain or antenna-to-antenna isolation measurements in the field.

The Variable Bias Tee Option (Option 10) can be used to place between $+12$ V to $+32$ V, in 0.1 V increments, on the center conductor of the RF In port. It is designed to deliver 500 mA at $+12$ V and 250 mA at $+24$ V.

Example

This example describes a Gain measurement of a TMA (Tower Mounted Amplifier) using the built-in bias tee (Option 10).

Procedure

1. Press the **Measurement** main menu key and press 2-port Gain.
2. Press the **Freq/Dist** main menu key and set the Start Frequency and Stop Frequency.
3. Connect test port extension cables to the RF Out port and the RF In port.
4. Press the **Shift** key, then the **Calibrate** (2) key.
5. Press the Cal Type submenu key to set the calibration to 2-Port.
6. Press the Cal Power submenu key and set power to Low.
7. Press the Start Cal submenu key and perform a 2-port OSL calibration at the end of the extension cables. See [“2-Port Calibration Procedure \(OSLIT\)” on page 3-3](#).
8. Connect the RF Out cable to the ANT port of the TMA.
9. Connect the RF In cable to RX port of the TMA.
10. Open the Bias Tee menu by pressing the following keys: **Shift**, **System** (8), the Application Options submenu key, and then the **Bias Tee** submenu key.
11. Set the appropriate voltage and current range for the amplifier using the Bias Tee Voltage and Current submenu keys. Note that the voltage will be applied to the center conductor of the RF In port.
12. Turn on the Bias Tee by pressing the Bias Tee On/Off submenu key.

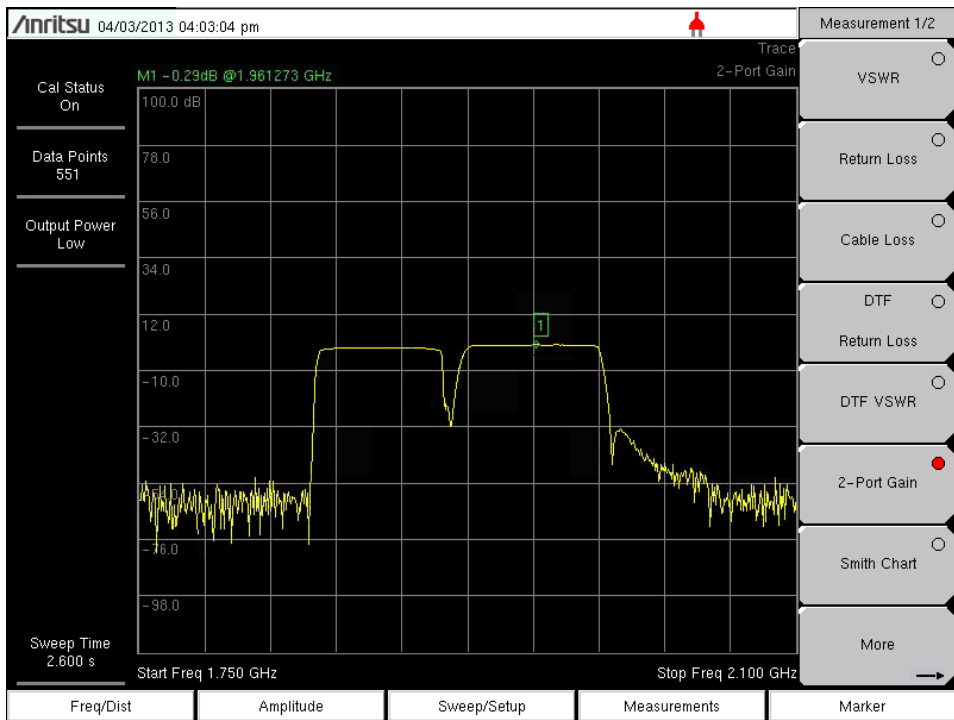

Figure 2-16. 2-Port Gain of a TMA

2-8 Phase Measurements

Phase measurements are available in both S11 and S21 modes. 2-Port Phase measurements can use both High (approximately -7 dBm) and Low (approximately -40 dBm) power settings.

1-Port Phase Measurement

The following example compares the phase of two cables using a 1-port phase measurement. The dynamic range and phase uncertainty are better with 2-port phase measurements.

Procedure

1. Press the **Measurement** main menu key.
2. Press the **More** submenu key.
3. Press the **1-port Phase** submenu key.
4. Set the Start Frequency and Stop Frequency or press **Signal Standard** to list the Signal Standard menu. If Signal Standard is pressed, determine the type of signal by pressing **Uplink**, **Downlink**, or **Uplink plus Downlink**. Then press the **Select Standard** submenu key to choose a signal from the Signal Standards List with the arrow keys or rotary knob and press **Enter**.
5. Press the **Shift** key, then the **Calibrate** (2) key and perform a 1-port calibration at the desired reference plane. See [“1-Port Calibration Procedure \(OSL\)” on page 3-1](#).
6. Connect Cable A to the RF Out reference plane.
7. Press the **Shift** key, then the **Trace** (5) key.
8. Press the **Copy Trace to Display Memory** submenu key.
9. Remove Cable A and connect Cable B to the RF Out reference plane.
10. Press the **Trace – Memory** submenu key to view the difference in phase between the two cables.
11. [Figure 2-17 on page 2-23](#) shows the difference in phase of cable A and cable B. The Trace Math menu is turned on and Trace A – Trace B is displayed.

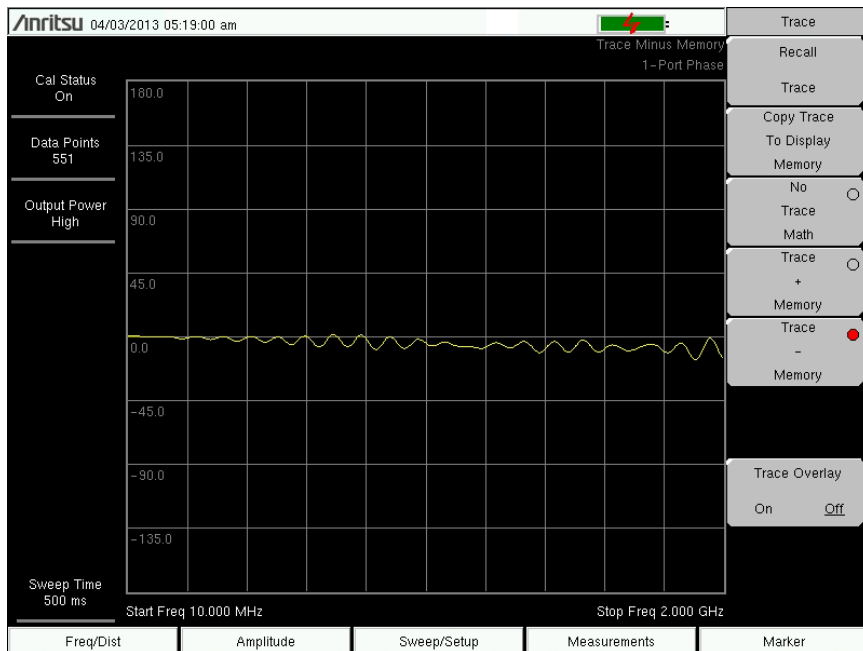

Figure 2-17. 1-Port Phase

2-Port Phase Measurement

The following example compares the phase of two cables using a 2-port phase measurement.

Procedure

1. Press the **Measurement** main menu key.
2. Press the **More** submenu key.
3. Press the **2-port Phase** submenu key.
4. Set the **Start Frequency** and **Stop Frequency** or press **Signal Standard** to list the **Signal Standard** menu. If **Signal Standard** is pressed, determine the type of signal by pressing **Uplink**, **Downlink**, or **Uplink plus Downlink**. Then press the **Select Standard** submenu key to choose a signal from the **Signal Standards List** with the arrow keys or rotary knob and press **Enter**.
5. Press the **Shift** key, then the **Calibrate** (2) key and perform a 2-port calibration at the end of a phase stable cable. See “[2-Port Calibration Procedure \(OSLIT\)](#)” on page 3-3.
6. Connect Cable A (the reference cable) between the RF Out and RF In connectors.
7. Press the **Shift** key, then the **Trace** (5) key.
8. Press the **Copy Trace to Display Memory** submenu key.
9. Remove Cable A and connect Cable B (the cable under evaluation).
10. Press the **Trace – Memory** submenu key to view the difference in phase between the two cables.

2-9 Smith Chart

1-port measurements can be displayed in a standard normalized 50Ω Smith Chart. When markers are used, the real and imaginary components of the Smith Chart value are displayed.

Anritsu Line Sweep Tools includes more options and a calculator that can easily show what the return loss, VSWR, or reflection coefficient values of a specific Smith Chart value.

Limit Lines in a Smith Chart will appear as circles (constant reflection coefficient) and can be entered in VSWR units.

Smith Chart Measurement

The following example shows how a Smith Chart can be used to measure the match of an antenna.

Procedure

1. Press the **Measurement** main menu key.
2. Press the Smith Chart submenu key.
3. Press the **Freq/Dist** main menu key and set the Start Frequency and Stop Frequency.
4. Press the **Start Cal** submenu key and perform a 1-port calibration. See “[1-Port Calibration Procedure \(OSL\)](#)” on page 3-1.
5. Connect the antenna to the RF Out connector on the BTS Master.

[Figure 2-18](#) represents a typical Smith Chart display. This is an example only. The measurement that is displayed on your instrument may be different.

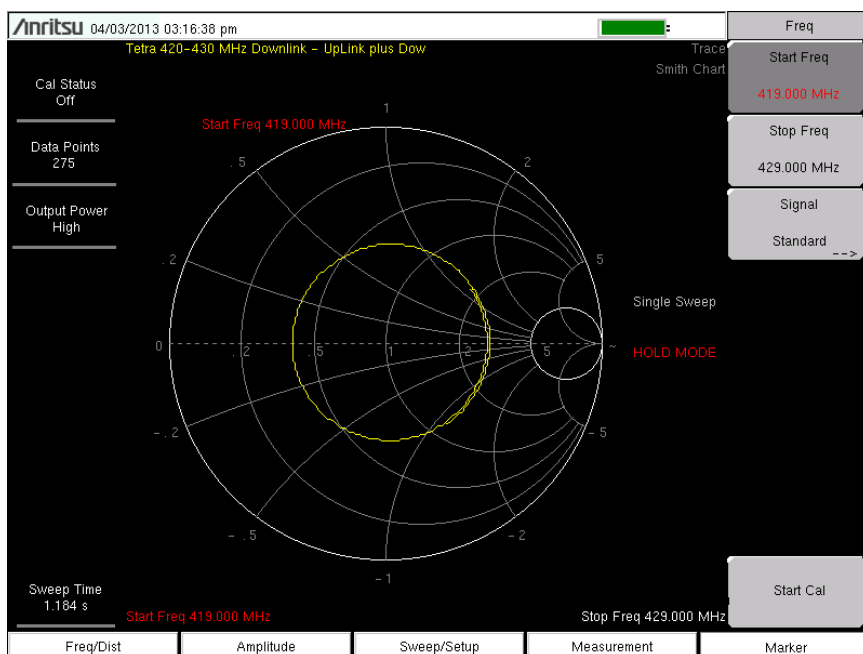

Figure 2-18. Smith Chart

2-10 Cable and Antenna Analyzer Menus

Figure 2-19 and Figure 2-20 show the map of the Cable and Antenna Analyzer menus. The following sections describe main menus and associated submenus. The submenus are listed in the order they appear on the display from top to bottom under each main menu.

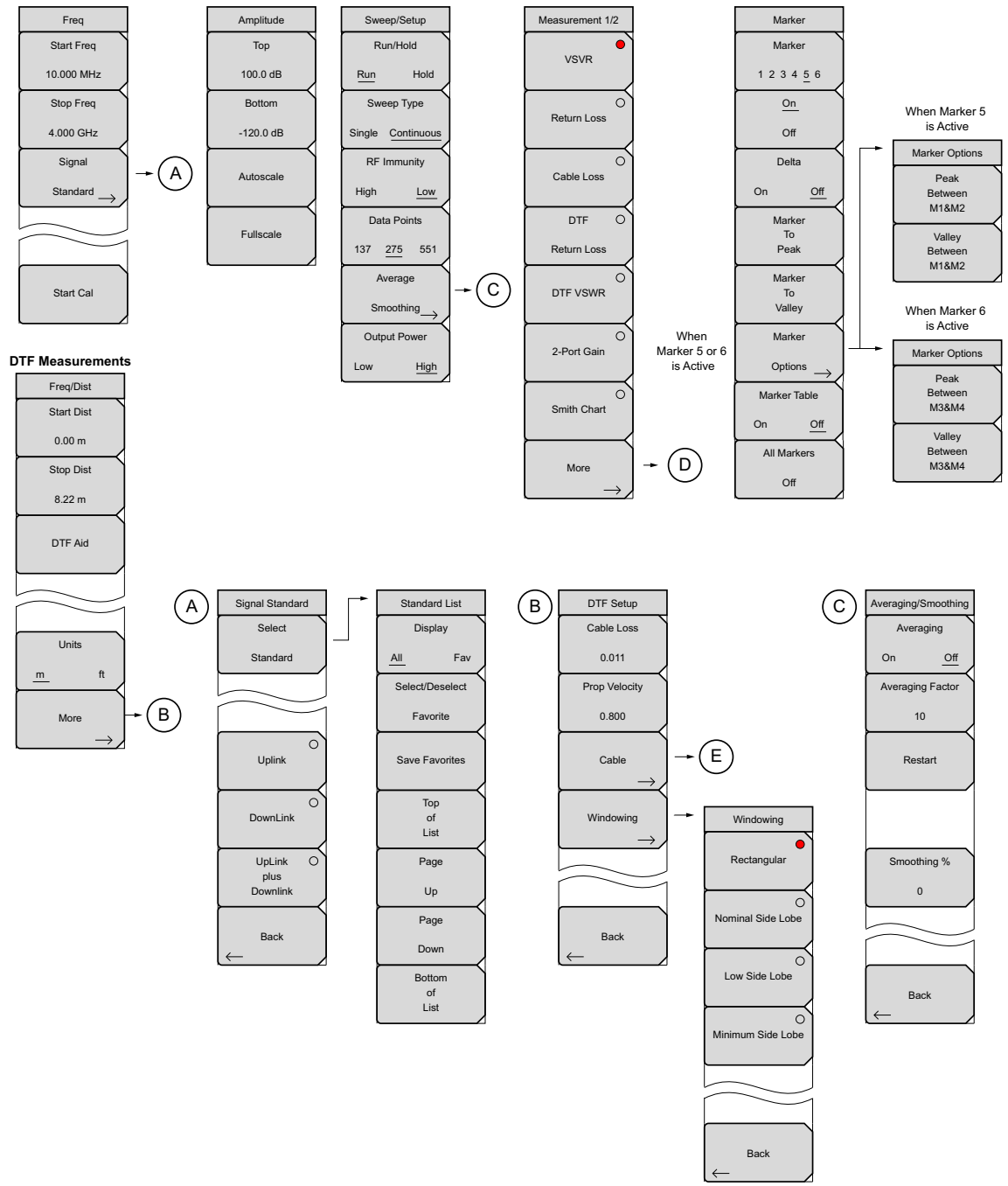
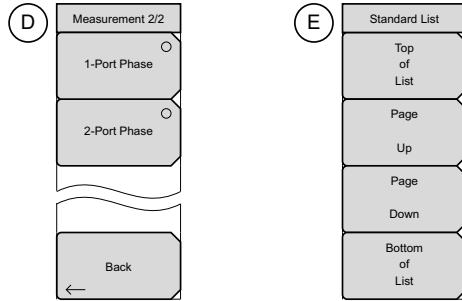

Figure 2-19. Main Menu Keys (1 of 2)



Refer to Chapter 3 for Menu Information

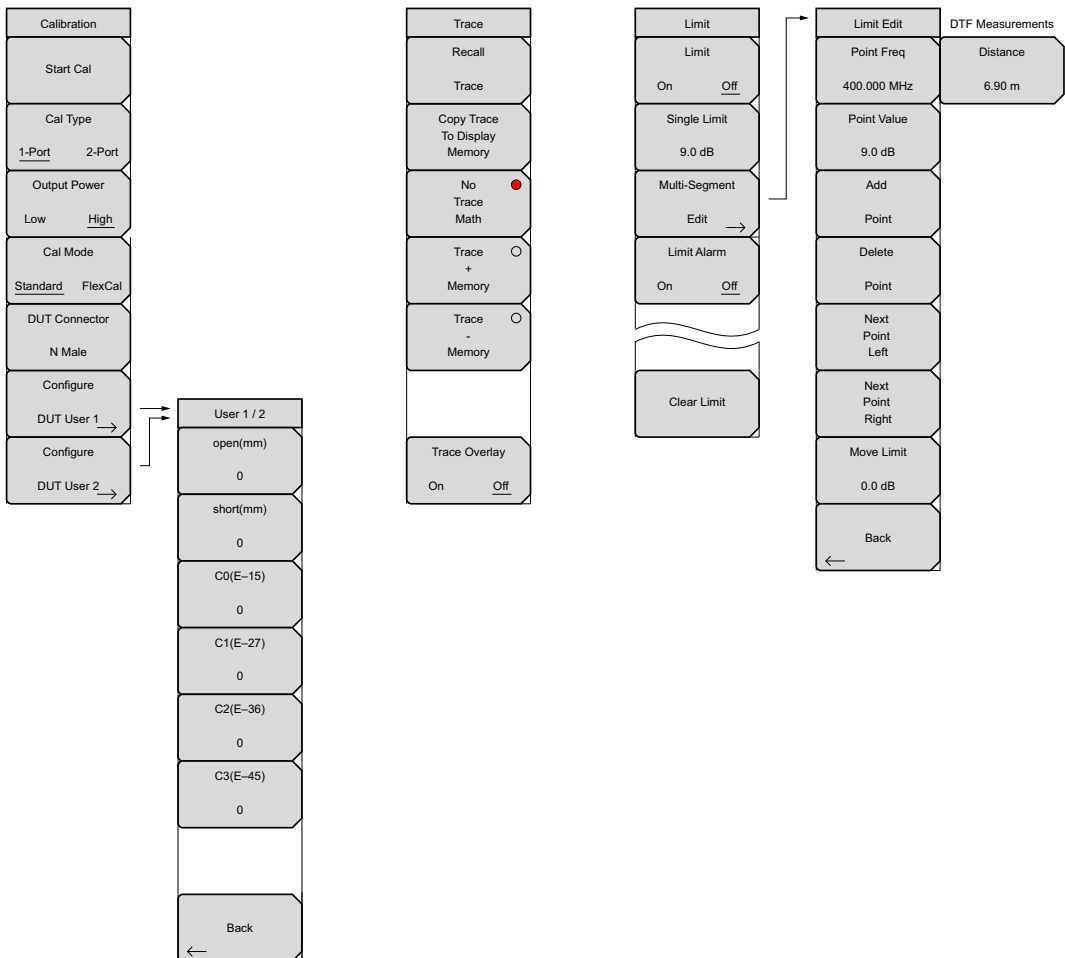

Figure 2-20. Main Menu Keys (2 of 2)

2-11 Freq/Dist Menu

The **Freq/Dist** main menu key opens the Freq menu, or the Freq/Dist menu, depending upon the type of measurement selected with the [“Measurement Menu” on page 2-33](#).

Pressing the **Freq/Dist** main menu key after selection of VSWR, Return Loss, Cable Loss, 2-Port Gain, Smith Chart, 1-Port Phase or 2-Port Phase on the **Measurement** main menu will open the menu shown below.

Key Sequence: **Freq**

| | |
|--------------------------|--|
| Freq | |
| Start Freq 10.000 MHz | Start Frequency: Press the Start Freq submenu key and enter the desired frequency using the keypad, the arrow keys, or the rotary knob. If a start frequency higher than the current stop frequency is entered, the stop frequency will be automatically adjusted. |
| Stop Freq 4.000 GHz | Stop Frequency: Press the Stop Freq submenu key and enter the desired frequency using the keypad, the arrow keys, or the rotary knob. If a stop frequency lower than the current start frequency is entered, the start frequency will be automatically adjusted. |
| Signal Standard → | Signal Standard: Opens the “Signal Standard Menu” on page 2-28 . When a signal standard is selected, the center frequency and span for the first channel of the particular standard is automatically tuned. Other settings, such as channel spacing and integration bandwidth, are also automatically entered. |
| Start Cal | Start Cal: Press this submenu key and follow the instruction on screen to begin calibration. See Chapter 3 details. |

Figure 2-21. Freq Menu

Signal Standard Menu

Key Sequence: **Freq/Dist** > Signal Standard

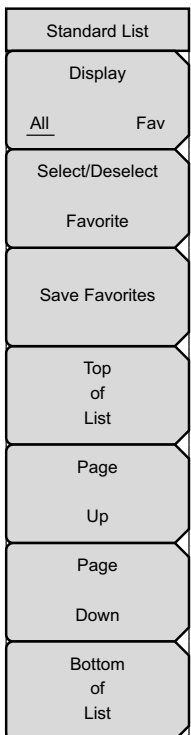
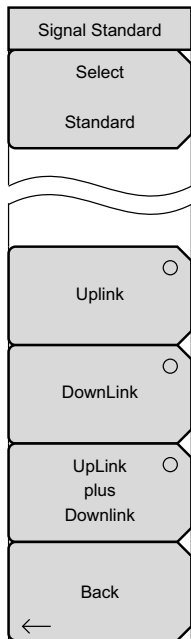

Select Standard: Opens the Signal Standards dialog box. Select the signal standard using the arrow keys, the rotary knob, or the touch screen. When a signal standard is selected, the start and stop frequency is automatically set. Other settings, such as channel spacing and integration bandwidth, are also automatically entered.

Display All/Fav: Toggles between showing all signal standards based on the UpLink, Downlink, or UpLink plus DownLink selection or displaying the signal standard selected as favorites.

Select/Deselect Favorite: Selects the signal standard is the dialog box. Signal names selected as favorites have an "*" in the Fav column of the dialog box. Press **Enter** or Save Favorites to save.

Save Favorites: Saves the signal selected to the favorites list.

Top of List: Moves the selection to the first signal standard in the list.

Page Up: Moves up one page view from the current signal name.

Display: Moves down one page view from the current signal name.

Bottom of List: Moves the selection to the last signal standard in the list.

Press **Esc** to return to the Signal Standard menu.

Uplink: Press to display only uplink frequencies.

Downlink: Press to display only downlink frequencies.

UpLink plus Downlink: Press to display both uplink and downlink frequencies.

After pressing one of the above three keys, press **Select Standard** to see the results reflected in the Signal Standard dialog box.

Back: Returns to the ["Freq/Dist Menu"](#) on page 2-27.

Figure 2-22. Signal Standard Menu

2-12 Freq/Dist Menu

The **Freq/Dist** main menu key opens the Freq menu, or the Freq/Dist menu, depending upon the type of measurement selected with the “[Measurement Menu](#)” on page 2-33.

Pressing the **Freq/Dist** main menu key after selection of DTF Return Loss or DTF VSWR on the **Measurement** main menu will display the menu below.

Key Sequence: **Freq/Dist**

| | |
|----------------------|--|
| Freq/Dist | <p>Start Freq: Press the Start Freq submenu key and enter the desired start frequency using the keypad, the arrow keys, or the rotary knob.</p> <p>Stop Freq: Press the Stop Freq submenu key and enter the desired stop frequency using the keypad, the arrow keys, or the rotary knob.</p> <p>DTF Aid: Opens the DTF Aid dialog box (Figure 2-12) for entering parameters.</p> <p>Units: Toggles between meters and feet.</p> <p>More: Opens the “DTF Setup Menu” on page 2-30.</p> |
| Start Dist 0.00 m | |
| Stop Dist 8.22 m | |
| DTF Aid | |
| Units <u>m</u> ft | |
| More → | |

Figure 2-23. Freq/Dist Menu

DTF Setup Menu

Key Sequence: **Freq/Dist** > More

| | |
|--|---|
|  | <p>Cable Loss: Press the Cable Loss submenu key and enter the loss in dB/ft or dB/m for the selected cable using the keypad, the arrow keys, or the rotary knob and press Enter.</p> <p>Prop Velocity: Press the Prop Velocity submenu key and enter the applicable propagation velocity for the selected cable using the keypad, the arrow keys, or the rotary knob and press Enter.</p> <p>Cable: The Cable submenu key opens a list of available cable specifications (see Figure 2-11). Using the arrow keys, the rotary knob, or the touch screen, select the desired cable and press Enter.</p> <p>Note: When a cable is selected from this list, propagation velocity and cable loss are automatically set by the unit.</p> <p>Windowing: Opens the Windowing menu. Options are:</p> <ul style="list-style-type: none"> • Rectangular • Nominal Side Lobe • Low Side Lobe • Minimum Side Lobe <p>Refer to Appendix A for more information on windowing.</p> <p>Back: Returns to “Freq/Dist Menu” on page 2-29.</p> |
|--|---|

Figure 2-24. DTF Setup Menu

2-13 Amplitude Menu

Key Sequence: **Amplitude**

| | |
|---------------------|---|
| Amplitude | Top: Sets the top amplitude value. |
| Top 100.0 dB | Bottom: Sets the bottom amplitude value. |
| Bottom -120.0 dB | Autoscale: Adjusts the Top and Bottom values so that the trace will be shown in the middle of the display. |
| Autoscale | Fullscale: Fullscale automatically sets the scale to the default setting (0 dB to 60 dB for Return Loss and 1 dB to 65 dB for VSWR). |
| Fullscale | |

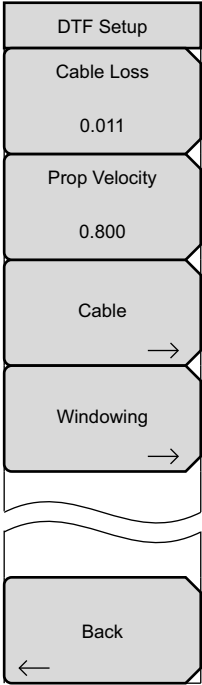
Figure 2-25. Amplitude Menu

2-14 Sweep/Setup Menu

Key Sequence: **Sweep/Setup**

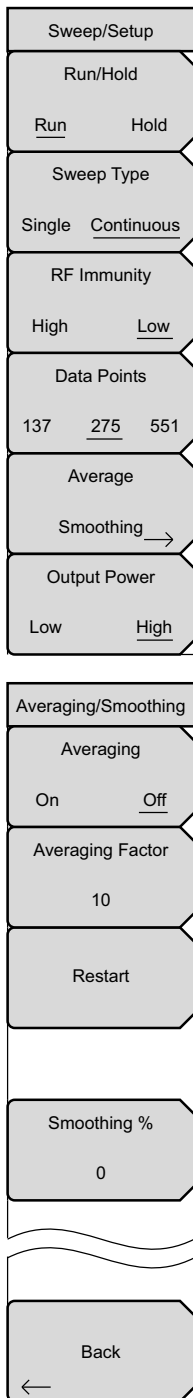

Run/Hold: Toggles between Run and Hold. When in Hold mode, pressing this key starts the sweeping and provides a trigger. When in the Run mode, pressing this key pauses the sweep.

Sweep Type: This toggles the sweep between single sweep and continuous sweep. In single sweep mode, each sweep must be activated by the Run/Hold key.

RF Immunity, High / Low: The instrument defaults to RF Immunity High and is the suggested setting.

Data Points: Opens the data points dialog box. Use the touch screen to set the number of data points: 137, 275, or 551.

Average/Smoothing: Opens the Average/Smoothing submenu.

Averaging: Toggles Averaging on or off.

Averaging Factor: Enter the number of running averages using the arrow keys, rotary knob, or the keypad.

Restart: Press the Restart key to start the averaging sequence from the beginning.

Smoothing %: Smoothing calculates a rolling average of the trace data. Valid entries range from 0% (no smoothing) to 10% (max. smoothing).

Back: Returns to the Sweep/Setup menu.

Output Power: The power level defaults to High for all 1-port measurements (~ -7 dBm). It can be changed to Low (~ -40 dBm) if needed.

Figure 2-26. Sweep/Setup Menu

2-15 Measurement Menu

Key Sequence: **Measurement**.

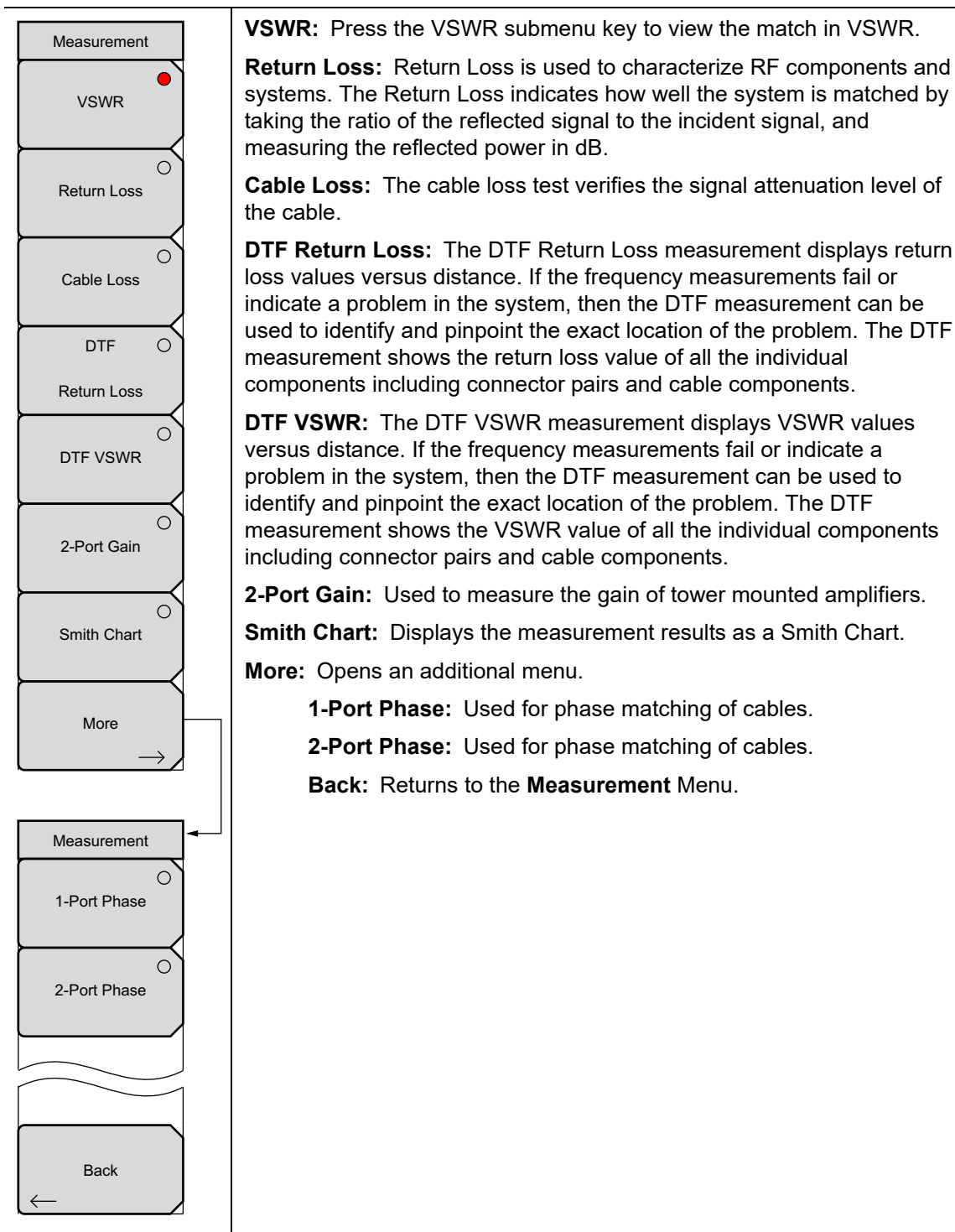

Figure 2-27. Measurement Menu

2-16 Marker Menu

Key Sequence: **Marker**

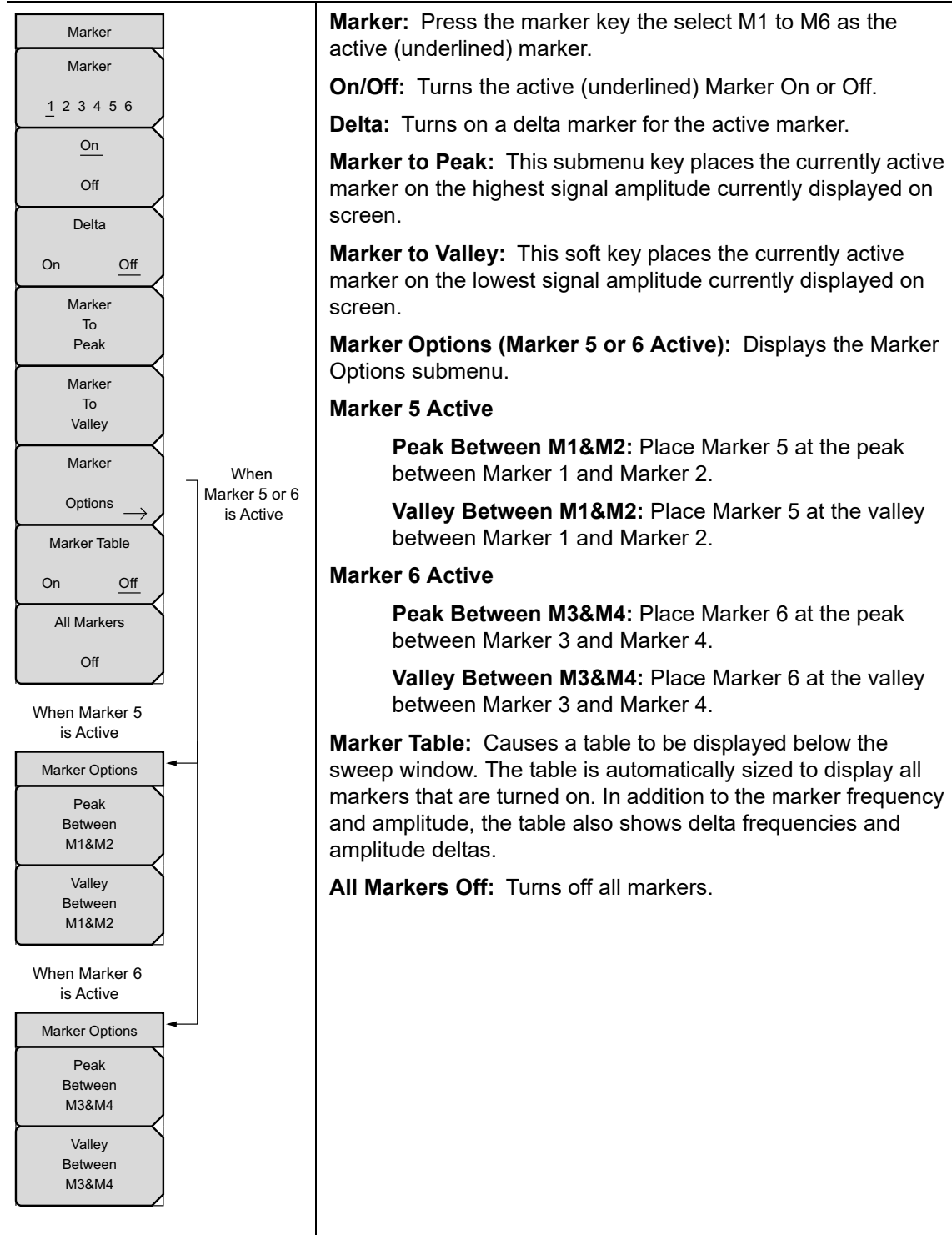

Figure 2-28. Marker Menu

2-17 Sweep Menu

This menu opens the [“Sweep/Setup Menu”](#) on page 2-32.

2-18 Measure Menu

This menu opens the [“Measurement Menu”](#) on page 2-33.

2-19 Trace Menu

Key Sequence: **Shift** > **Trace** (5) key

| | |
|---|--|
| Trace | Recall Trace: Opens the Recall dialog box to recall a previously saved measurement. See the User Guide for more information about recalling measurements. If the setup of the recalled trace is the same as the current settings, the trace is displayed in white and copied to display memory for use in Trace Math. |
| Recall Trace | |
| Copy Trace To Display Memory | Copy Trace to Memory: Copies the current trace display to memory for use in Trace Math. |
| No Trace Math <input checked="" type="radio"/> | No Trace Math: The active trace is shown as is with no math functions. |
| Trace + Memory <input type="radio"/> | Trace + Memory: Displays the results of logarithmic adding of the active trace and the trace in memory. |
| Trace - Memory <input type="radio"/> | Trace – Memory: Displays the difference between the active trace and the trace in memory. |
| Trace Overlay On <input type="radio"/> Off <input type="radio"/> | Trace Overlay: Displays both the recalled trace (white) if a trace is stored in memory and the current trace (yellow). |

Figure 2-29. Trace Menu

2-20 Limit Menu

A limit line can be used for visual reference only, or for pass/fail criteria using the limit alarm. Limit alarm failures are reported whenever a signal is above the upper limit line or below the lower limit line.

A limit line can consist of a single segment, or as many as 40 segments across the entire frequency span of the instrument. These limit segments are retained regardless of the current frequency span of the instrument, allowing the configuring of specific limit envelope at various frequencies of interest without having to re-configure them each time the frequency is changed. To clear the current limit setup configuration and return to a single limit segment starting at the current start frequency and ending at the current stop frequency, press the Clear Limit submenu key.

Key Sequence: **Shift > Limit**

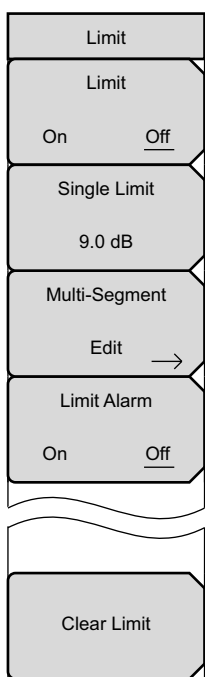

Limit: This submenu key turns the limit line on or off.

Single Limit: This key create a single segment limit line. The amplitude of the limit line is adjusted with the arrow keys, rotary knob, or the numeric keypad.

Multi-Segment Edit: The [“Limit Edit Menu” on page 2-37](#) displays and allows the creation or editing of single or multi-segment limit lines. The currently active limit point is marked by a red circle on the display.

Limit Alarm: For the currently active limit line, this submenu key selects whether an alarm beep will occur when a data point exceeds the limit.

Clear Limit: This submenu key deletes all limit points for the currently active limit line.

Figure 2-30. Limit Menu

Limit Edit Menu

Key Sequence: **Shift** > **Limit** (6) key > Limit Edit

| | |
|---------------------------|---|
| Limit Edit | <p>Point Frequency: The frequency of each point in a limit line can be individually set. When a new point is added, it takes on a value halfway between two existing points, or the stop frequency of the current sweep if there is no point higher in frequency than the one being added. See the Add Point submenu key description for more details. Use the keypad, the Left/Right arrow keys or the rotary knob to change the frequency of a point.</p> <p>Point Value: The amplitude of each limit point can also be individually set. By default, when a new point is added, it takes on the amplitude that is on the limit line at the frequency where the point was added. Use the keypad, using the \pm key as the minus sign, the Up/Down arrow keys or the rotary knob to move the point to the desired value. The unit of the amplitude limit is the same as the current vertical amplitude unit. See the Add Point submenu key description for more details.</p> <p>Add Point: The precise behavior of this submenu key depends on which limit point is active at the time the key is pressed. If the active limit point is somewhere in the middle of a multi-segment limit line, a new limit point will be added that is halfway between the currently active point and the point immediately to its right. The amplitude of the point will be such that it falls on the limit line. For example, if there is a limit point at 2.0 GHz with an amplitude of -30 dBm and the next point is 3.0 GHz with an amplitude of -50 dBm, the added point will be at 2.5 GHz with an amplitude of -40 dBm. The frequency and amplitude values of the new point can be adjusted as needed with the Frequency and Amplitude submenu keys. If the last limit point is active (assuming it is not at the right edge of the display) the new limit point will be placed at the right edge of the display at the same amplitude as the point immediately to its left. Points may not be added beyond the current sweep limits of the instrument.</p> <p>Delete Point: This submenu key deletes the currently active point. The active point becomes the one immediately to the left of the point that was deleted.</p> <p>Next Point Left: This submenu key selects the limit point immediately to the left of the active point, making it active for editing or deletion. With each key press, the indicator of which point is active moves one limit point to the left until it reaches the left edge of the screen.</p> <p>Next Point Right: This submenu key selects the limit point immediately to the right of the active point, making it active for editing or deletion. With each key press, the indicator of which point is active moves one limit point to the right until it reaches the right edge of the screen.</p> <p>Move Limit: This submenu key allows an entire single or multi-segment limit line to be moved up or down by the number of dB entered using the keypad, the Up/Down arrow keys, or the rotary knob. The units for this amount will be the current display units as selected under the Amplitude menu.</p> <p>Back: Returns to “Limit Menu” on page 2-36.</p> |
| Point Freq 400.000 MHz | |
| Point Value 9.0 dB | |
| Add Point | |
| Delete Point | |
| Next Point Left | |
| Next Point Right | |
| Move Limit 0.0 dB | |
| Back ← | |

Figure 2-31. Limit Edit Menu

2-21 Other Menus

Preset, **File**, **Mode** and **System** are described in the User Guide. **Calibrate** is described in [Chapter 3](#).

Chapter 3 — Calibration

3-1 Calibration

For accurate results, the BTS Master must be calibrated at the ambient temperature after allowing for warm up time and before making any measurements. The BTS Master must be re-calibrated whenever the setup frequency changes or when a test port extension cable is added, removed or replaced. If FlexCal for 1-port was performed, frequency changes do not require re-calibration.

The 1-port calibration is an Open-Short-Load (OSL) calibration removing source match, directivity, and frequency response errors.

The 2-port calibration is a 1-path 2-port calibration and removes transmission response errors and transmission source match errors in addition to reflection error terms.

Users can perform a standard open, short, load cal, or a FlexCal for 1-port measurements. FlexCal eliminates the need to perform multiple calibrations after changing the frequency. It is more time efficient than the standard cal and Anritsu recommends it for troubleshooting. For optimum accuracy, however, the standard cal should be used. FlexCal is appropriate for large frequency spans but is less precise at very narrow spans due to the frequency span used during the FlexCal operation.

Note

If a Test Port Extension Cable is to be used, the BTS Master must be calibrated with the Test Port Extension Cable in place. The Test Port Extension Cable is a phase stable cable and is used as an extension cable on the test port to ensure accurate and repeatable measurements. This phase stable cable can be moved and bent while making a measurement without causing errors in the measurement.

1-Port Calibration Procedure (OSL)

1. If a test port extension cable is to be used, connect the cable to the RF Out connector on the BTS Master. The calibration components will be connected at the end of the cable (Figure 3-1).
2. Set the frequency range, refer to “[Frequency](#)” on page 2-2 for additional information.
3. Press the **Shift** key and then the **Calibrate** (2) key.
4. On the Cal Mode submenu key, select **Standard** or **FlexCal**.

FlexCal is a broadband calibration that allows you to change the frequency after calibration. It is more time efficient and particularly helpful if you are troubleshooting the system. For optimum accuracy, the Standard Cal method is recommended.

5. Verify that the Device Under Test (DUT) connector, as shown on the DUT Connector submenu key, is appropriate for the test setup. To choose a different connector, press the DUT Connector submenu key and use the rotary knob or **Up/Down** arrow keys to highlight the appropriate connector and press the rotary knob or **Enter** to select.

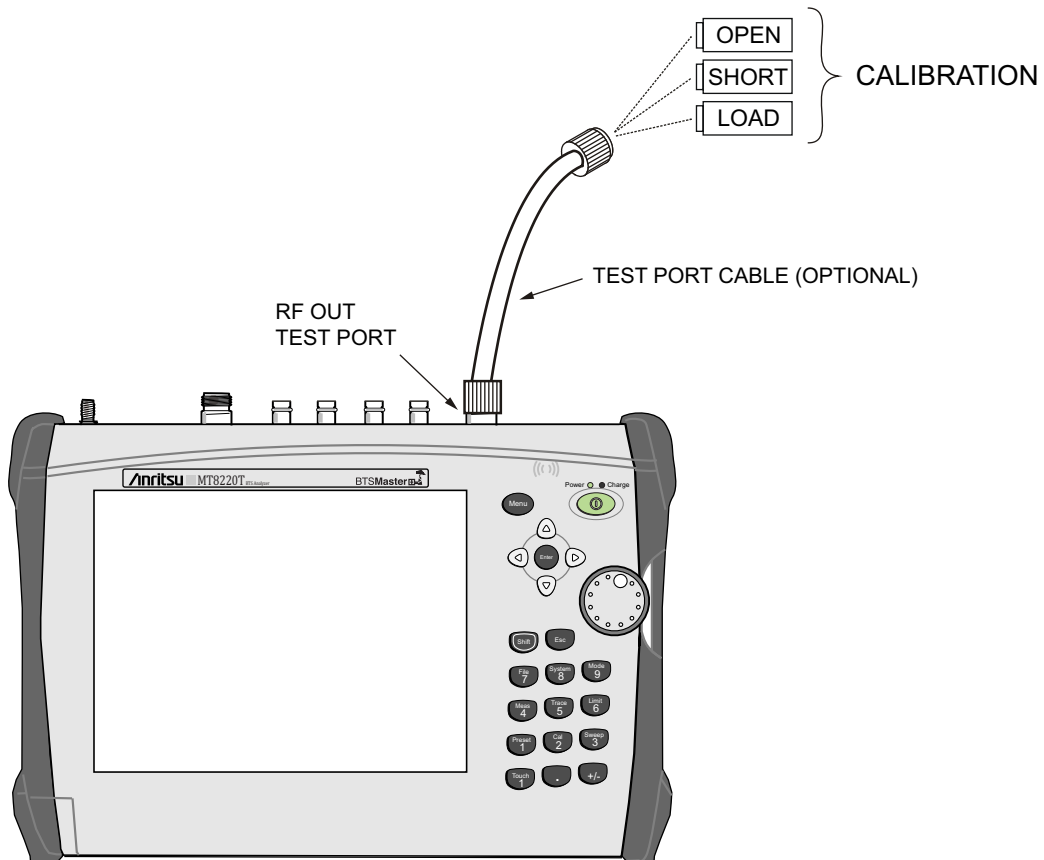

Figure 3-1. 1-Port Calibration

6. Press the **Start Cal** submenu key.
7. Connect the Open to the RF Out port (or to the end of the test port extension cable) and press the **Enter** key.
8. When prompted, connect the short to the RF Out port (or to the end of the test port extension cable) and press the **Enter** key.
9. When prompted, connect the Load to the RF Out port (or to the end of the test port extension cable) and press the **Enter** key.
10. Verify that calibration has been performed properly by checking that the **Cal Status On** message is now displayed at the top of the status window.

2-Port Calibration Procedure (OSLIT)

1. If a test port extension cable is to be used, connect the cable to the RF Out and/or RF In connector on the BTS Master. The calibration components will be connected at the end of the cable (Figure 3-2).
2. Set the frequency range, refer to “Frequency” on page 2-2 for additional information.
3. Press the **Shift** key and then the **Calibrate (2)** key.
4. If none of the connectors shown in the DUT Connector Selector list are suitable for the application, there are two selections, User 1 and User 2, that can be custom defined. To edit the characteristics, select the **User 1** or **User 2** submenu key. The menu allows editing the offset lengths for the Open and Short, and the capacitance values for the Open. To change a value, press the appropriate submenu key, enter the desired value using the numeric keypad, and press **Enter** to accept. When all values are correct, press the **Back** submenu key to return to the Calibration menu.

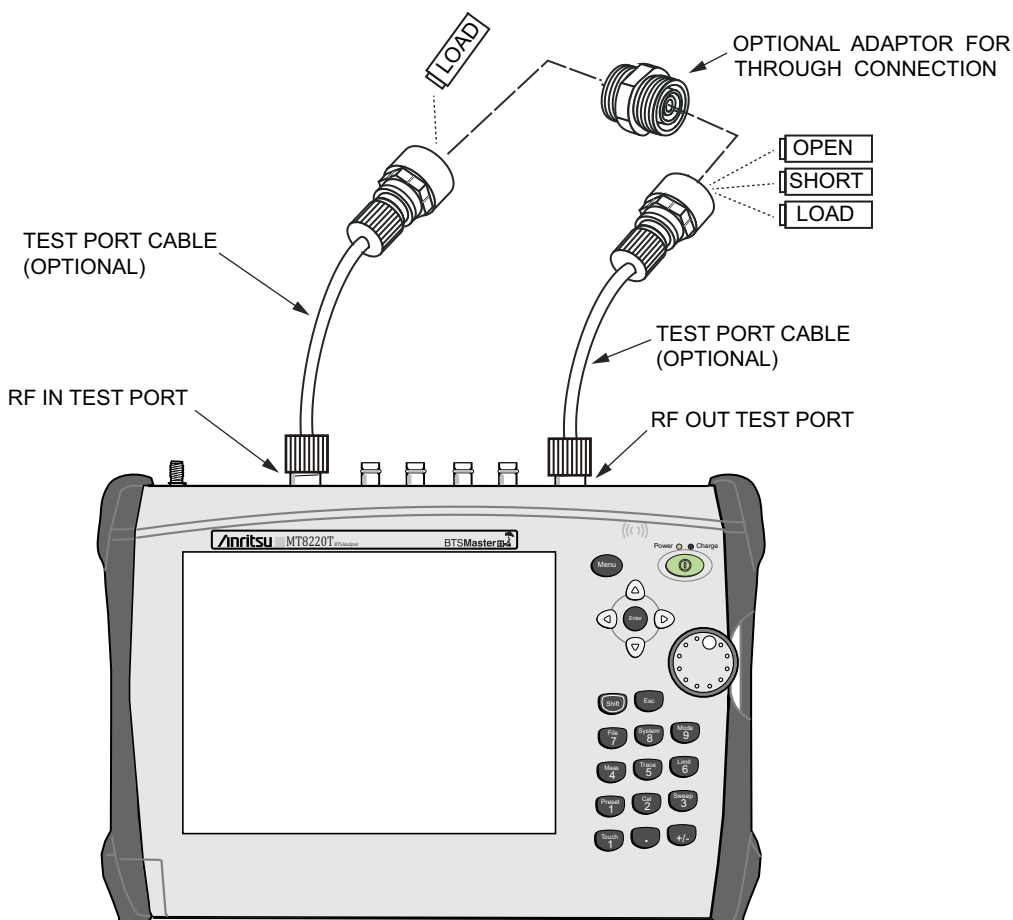

Figure 3-2. 2-Port Calibration

5. Press the Output Power submenu key to set the power level to Low (−40 dBm) or High (−7 dBm).
6. Press the Start Cal submenu key.

7. Connect the Open to the RF Out port (or to the end of the test port extension cable) and press the **Enter** key.
8. When prompted, connect the short to the RF Out port (or to the end of the test port extension cable) and press the **Enter** key.
9. When prompted, connect the Loads to the RF Out port (or to the end of the test port extension cable) and to the RF In port (or to the end of the test port extension cable) and press the **Enter** key.
10. Connect the RF Out port to the RF In port, including any test port extension cables used in the prior steps, and press the **Enter** key.
11. Verify that calibration has been performed properly by checking that the Cal Status On message is now displayed at the top of the status window.

3-2 Calibration Menu

Key Sequence: **Calibrate**

| | |
|---|---|
| <div style="border: 1px solid black; padding: 5px; margin-bottom: 5px;">Calibration</div> <div style="border: 1px solid black; padding: 5px; margin-bottom: 5px;">Start Cal</div> <div style="border: 1px solid black; padding: 5px; margin-bottom: 5px;">Cal Type 1-Port <u>2-Port</u></div> <div style="border: 1px solid black; padding: 5px; margin-bottom: 5px;">Output Power Low <u>High</u></div> <div style="border: 1px solid black; padding: 5px; margin-bottom: 5px;">Cal Mode Standard <u>FlexCal</u></div> <div style="border: 1px solid black; padding: 5px; margin-bottom: 5px;">DUT Connector N Male</div> <div style="border: 1px solid black; padding: 5px; margin-bottom: 5px;">Configure DUT User 1 →</div> <div style="border: 1px solid black; padding: 5px; margin-bottom: 5px;">Configure DUT User 2 →</div> | <p>Start Cal: Press this submenu key and follow the instruction on screen.</p> <p>Cal Type: Toggles between 1-Port and 2-Port calibration.</p> <p>Output Power: Toggles between Low (-40 dBm) or High (-7 dBm) output power.</p> <p>Cal Mode: Toggles between Standard Cal and FlexCal.</p> <p>DUT Connector: Opens the DUT Connector Selector dialog box for selecting the connector type. Open, Short, C0, C1, C2, and C3 information is provided for each connector type.</p> <p>Configure DUT User 1: Opens the User 1 submenu where a custom connector type can be specified. Open, Short, C0, C1, C2, and C3 information can be created for the connector.</p> <p>Configure DUT User 2: Opens the User 2 submenu where a custom connector type can be specified. Open, Short, C0, C1, C2, and C3 information can be created for the connector.</p> |
|---|---|

Figure 3-3. Calibrate Menu

Appendix A — Windowing

A-1 Introduction

The theoretical requirement for inverse FFT is for the data to extend from zero frequency to infinity. Side lobes appear around a discontinuity because the spectrum is cut off at a finite frequency. Windowing reduces the side lobes by smoothing out the sharp transitions at the beginning and the end of the frequency sweep. As the side lobes are reduced, the main lobe widens, thereby reducing the resolution.

In situations where a small discontinuity may be close to a large one, side lobe reduction windowing helps to reveal the discrete discontinuities. If distance resolution is critical, then reduce the windowing for greater signal resolution.

If two or more signals are very near to each other, then spectral resolution is important. In this case, use **Rectangular Windowing** for the sharpest main lobe (the best resolution).

Examples of the windowing options' (**Freq/Dist > More > Window**) effects on a sample trace are shown in [“Examples” on page A-1](#).

In summary:

- **Rectangular Windowing** provides best spatial distance resolution for revealing closely spaced events, but the side lobes close to any major event (large reflection) may mask smaller events which are close to the major event. Excellent choice if multiple faults of similar amplitudes close together are suspected.
- **Nominal Side Lobe Windowing** provides very good suppression of close in side lobes, but compromises spatial distance resolution compared to Rectangular. Closely spaced events may appear as a single event, often non-symmetrical in shape. Excellent overall choice for most typical antenna system sweeps.
- **Low Side Lobe Windowing** provides excellent suppression of close in side lobes but spatial distance resolution is worse than Nominal Side Lobe. The additional suppression of side lobes may be useful in locating very small reflection events further away from large events. *It is not often used for field measurements.*
- **Minimum Side Lobe Windowing** provides highest suppression of side lobes but worst spatial distance resolution. Can be useful for finding extremely small events spaced further apart than the distance resolution. *Again, not typically used for field measurements.*

A-2 Examples

The types of windowing in order of increasing side lobe reduction are: rectangular, nominal side lobe, low side lobe, and minimum side lobe. [Figure A-1](#) through [Figure A-4](#) show examples of the types of windowing.

Rectangular Windowing

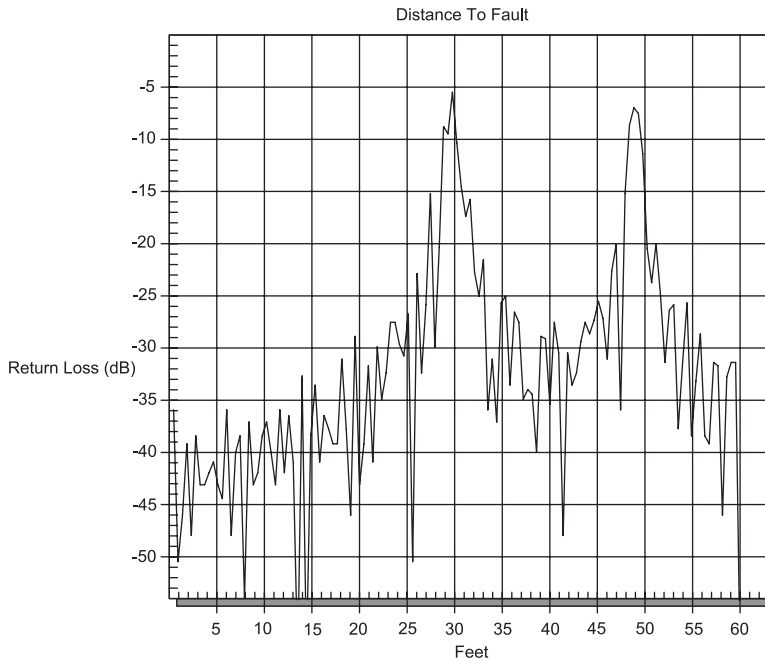

Figure A-1. Rectangular Windowing

Nominal Side Lobe Windowing

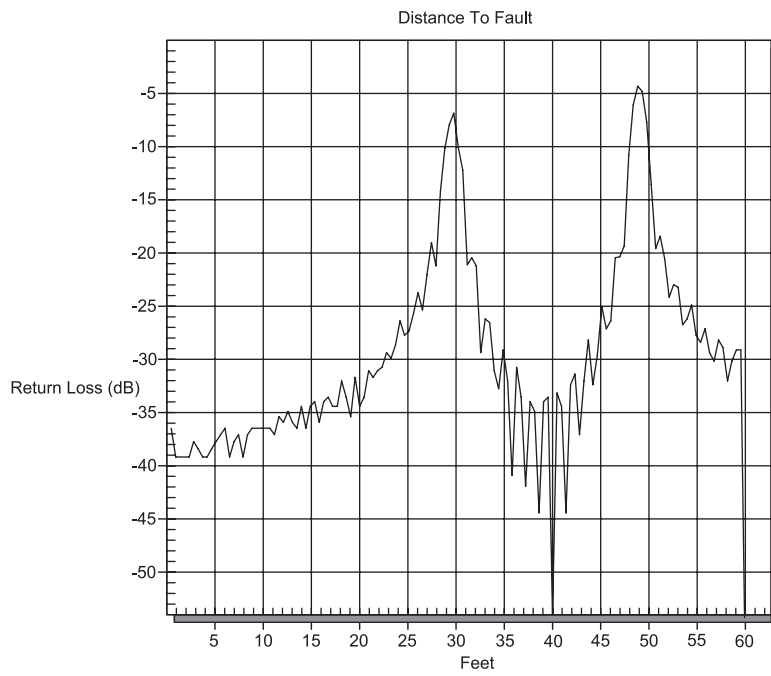

Figure A-2. Nominal Side Lobe Windowing

Low Side Lobe Windowing

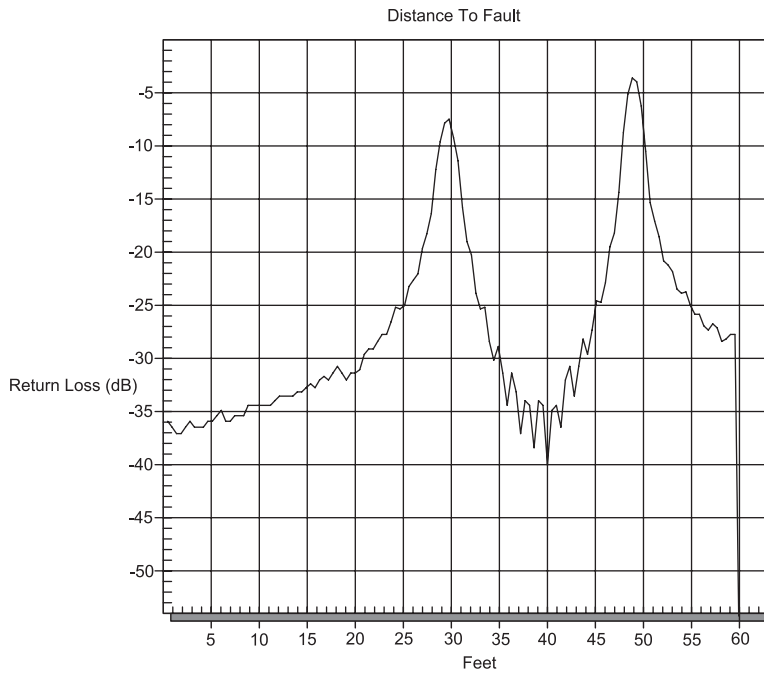

Figure A-3. Low Side Lobe Windowing

Minimum Side Lobe Windowing

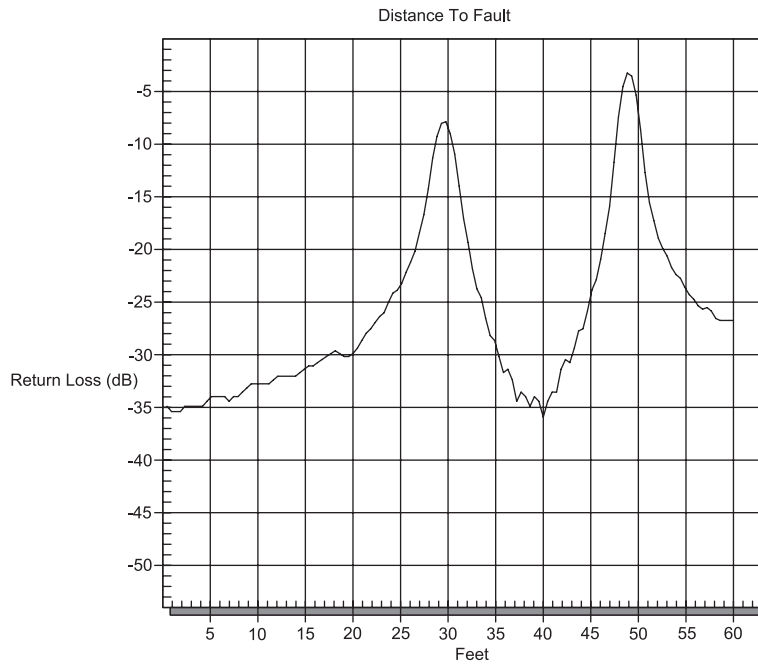

Figure A-4. Minimum Side Lobe Windowing

Appendix B — Tower Mounted Amplifiers

B-1 Introduction

A Tower Mounted Amplifier (TMA) can be used to amplify the received signal. There are different types of TMA depending upon the system requirements. Three commonly used types are:

- **TMA-D:** A duplex tower mounted amplifier that combines transmit and receive ports from the radio system and connects to a single antenna. This configuration is specific to systems that use a single antenna configuration.
- **TMA-S:** A receive-only tower mounted amplifier is installed between the receiving antenna and the radio to boost weak signals. This configuration is common on systems that implement separate antennas for transmitting and receiving.
- **TMA-DD:** A dual-duplex tower mounted amplifier used for radios systems with a single transmission line connection for transmit and receive. These systems are commonly called transceivers.

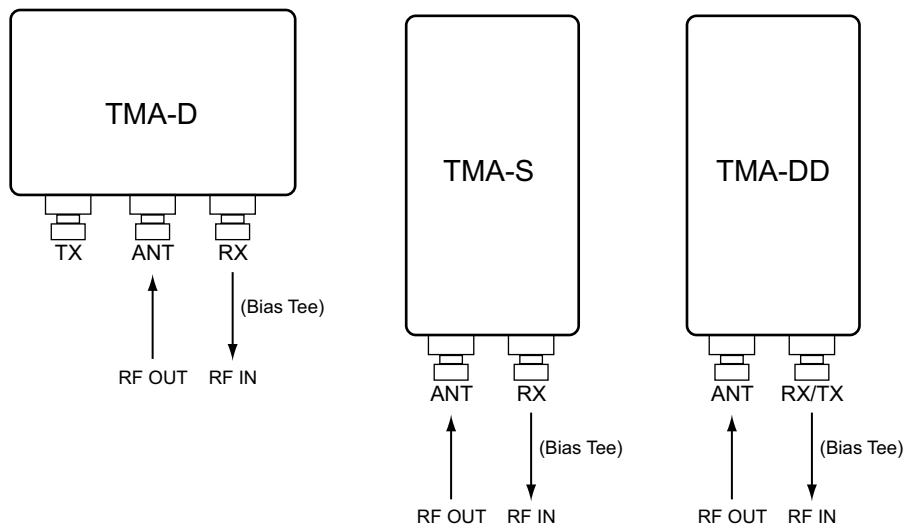

Figure B-1. Tower Mounted Amplifiers

Index

Numerics

1-port phase 2-33
 2-port gain 2-20, 2-33
 2-port phase 2-33

A

amplitude menu 2-31
 analysis mode selection 1-2
 Anritsu, contact 1-1
 antenna
 configuration, TMA B-1
 autoscale 2-31
 averaging 2-4, 2-32

C

cable 2-30
 cable and antenna analyzer menus .. 2-25
 cable loss 2-14, 2-33
 calibration 2-1
 1-port 3-1
 2-port 3-3
 calibration menu 3-4
 contacting Anritsu 1-1

D

data point 2-4
 distance-to-fault 2-15, 2-33
 DTF aid 2-17
 DTF setup menu 2-30

F

freq menu 2-27
 freq/dist menu 2-29
 frequency setup 2-2
 fullscale 2-31

L

limit edit menu 2-37
 limit lines setup 2-6
 limit menu 2-36

links, contact 1-1

M

marker menu 2-34, 2-35
 marker table 2-9, 2-34
 markers setup 2-8
 measurement menu 2-33
 measurement mode selection 1-2
 menu map 2-25

O

output power 2-5, 2-32

P

phase measurements
 1-port 2-22
 2-port 2-23
 prop velocity 2-30

R

return loss 2-12, 2-33
 RF immunity 2-4

S

signal standards 2-2, 2-27
 smith chart 2-24, 2-33
 smoothing 2-5
 sweep/setup menu 2-32

T

tower mounted amplifiers 2-15, B-1
 trace math 2-10, 2-35
 trace menu 2-35
 trace overlay 2-35

V

VSWR 2-12, 2-33

W

web links, contact 1-1
 windowing 2-30

Anritsu



Anritsu utilizes recycled paper and environmentally conscious inks and toner.

Anritsu Company
490 Jarvis Drive
Morgan Hill, CA 95037-2809
USA
<http://www.anritsu.com>