

ShockLine™

MS46122A/B, MS46131A, ME7868A, and MS46322A/B Series Vector Network Analyzer

MS46122A/B, 1 MHz to 43.5 GHz, 2-Port

MS46131A, 1 MHz to 43.5 GHz, 1-Port

ME7868A, 1 MHz to 43.5 GHz, 2-Port

MS46322AB, 1 MHz to 43.5 GHz, 2-Port



Anritsu

Table of Contents

Chapter 1—Calibration Overview

1-1	Manual Scope	1-1
1-2	Chapter Summary	1-1
1-3	Related Documentation	1-1
	Product Information, Compliance, and Safety	1-1
	ShockLine MS46122A/B Vector Network Analyzers	1-1
	ShockLine MS46131A Vector Network Analyzers	1-2
	ShockLine MS46322A/B Vector Network Analyzers	1-2
	Calibration, Verification, and System Performance Verification	1-2
	Calibration, Verification, and System Performance Verification	1-2
1-4	Calibration Kits, Verification Kits, and Test Port Cables	1-3
	Calibration/Verification Equipment Part Numbers and General Specifications	1-3
1-5	AutoCal Automatic Calibration Modules	1-6
	Calibrations Available	1-6
1-6	SOLT/SOLR Kits (365xx)	1-7
1-7	Offset Short Waveguide Kits (3655X)	1-7
1-8	Microstrip/Coplanar Waveguide Kits for the UTF (36804-XXX)	1-7
1-9	Calibration Algorithms	1-8
1-10	About Calibration	1-8
	Match	1-8
	Directivity	1-8
	Frequency Response	1-8
	Calibration Types	1-9
	Calibration Algorithms	1-9
1-11	Calibration Setup	1-10
	Frequency Start, Stop, and Number of Points	1-10
	IF Bandwidth, Averaging, and Power	1-10
1-12	Types of Calibrations	1-11
	Full 2 Port	1-11
	Full 1 Port	1-11
	1 Path 2 Port (Forward or Reverse)	1-11
	Frequency Response (Reflection Response and Transmission Frequency Response)	1-11
1-13	Line Types (Transmission Media)	1-13
1-14	Connector Precautions	1-15
	Pin Depth	1-15
	Pin Depth Tolerance	1-15
	Over-Torquing Connectors	1-16
	Teflon Tuning Washers	1-16
	Mechanical Shock	1-16
1-15	Connector Cleaning Instructions	1-17
	Required Cleaning Items	1-17
	Cleaning Procedure	1-18

Table of Contents (Continued)

Chapter 2—Automatic Calibration Procedures

2-1	Chapter Overview	2-1
2-2	Automatic Calibration Introduction	2-1
	Transfer Calibration	2-1
	Calibration Accuracy	2-1
2-3	Automatic Calibration Terms.	2-2
	Insertable and Non-Insertable Devices	2-2
	Auto-Sense	2-2
	Characterization File	2-2
2-4	Available Calibrator Modules and Adapters	2-4
	AutoCal Modules and Adapters.	2-5
	SmartCal Modules and Adapters.	2-5
	AutoCal Components.	2-6
	SmartCal Module	2-6
	Connector Care	2-6
	Calibration Parameters and Types	2-6
	Adapter Removal	2-7
	Through Options	2-7
	SmartCal Test Port 1 / Port 2 Naming Assignments	2-7
	AutoCal Test Port Left/Right Naming Assignments.	2-7
2-5	MS46122A/B Typical Calibrator Connections.	2-8
2-6	MS46322A/B Typical Calibrator Connections.	2-9
	Using the Calibration Module.	2-10
2-7	Copying the Calibrator Characterization File	2-12
	Procedure	2-12
2-8	Loading a Previously Stored AutoCal Characterization	2-13
	Procedure	2-13
2-9	Pre-Calibration Instrument Setup	2-14
	Segmented Sweep	2-14
	IF Bandwidth (IFBW) and Averaging	2-14
	Example Procedure	2-14
2-10	Calibration - Full Two Port - Internal Through.	2-17
	Required Equipment	2-17
	Procedure	2-17
2-11	Calibration - Two Port Cal - True Through	2-22
	Required Equipment	2-22
	Procedure	2-22
	Connect the True Through.	2-26
2-12	Calibration Module Characterization.	2-29
	Characterization.	2-29

Table of Contents (Continued)

2-13	Adapter Removal — M-M or F-F Reference Plane	2-31
	Adapter Removal Overview	2-31
	Required Equipment	2-31
	Prerequisites	2-31
	Procedure	2-31
Chapter 3—SOLT/SOLR Calibration		
3-1	SOLT/SOLR Introduction	3-1
3-2	Definitions	3-1
	Shorts	3-1
	Opens	3-1
	Loads	3-1
	Thru	3-1
	Reciprocal	3-1
3-3	Setup	3-2
3-4	SOLT/SOLR Calibration	3-8
Chapter 4—Offset Short (SSLT) Calibration		
4-1	SSLT Introduction	4-1
4-2	SSLT Calibration Example	4-3
Chapter 5—Triple Offset Short (SSST) Calibration		
5-1	SSST Introduction	5-1
5-2	SSST and Reflectivity Error Terms	5-1
5-3	SSST Calibration Example	5-4
Chapter 6—LRL/LRM Calibration		
6-1	LRL/LRM Introduction	6-1
6-2	LRL/LRM Comparison	6-1
	LRL — Line-Reflect-Line	6-1
	LRM — Line-Reflect-Match	6-1
	Reflection Offset Length and Reflection Type	6-6
6-3	LRL/LRM Calibration Step-by-Step Example	6-7
	Procedure	6-8
6-4	Hints and Suggestions	6-11
Chapter 7—Adapter Removal Calibrations and Network Extraction		
7-1	Introduction	7-1
7-2	Two Related Sets of Reference Planes	7-1
	Caveats and Limitations	7-2
7-3	Performing an Adapter Removal	7-6
	Example Adapter Removal	7-7
7-4	Network Extraction	7-9
	Overview	7-9
7-5	Type A Network Extraction	7-11

Table of Contents (Continued)

7-6	Type B Network Extraction	7-13
	Type B Network Extraction—Full Standards	7-13
	Type B Network Extraction—Flex Standards (with Option 24)	7-15
7-7	Type C Network Extraction	7-23
7-8	Type D Network Extraction	7-25
	Type D Network Extraction—Multi Standards (with Option 24)	7-26
	Type D Network Extraction—Phase Localized (with Option 24)	7-32
7-9	Sequential Extraction—Peeling (with Option 24)	7-38
7-10	Uncertainty and Sensitivity	7-42
7-11	Enforced Passivity and Causality	7-46
	Passivity	7-47
	Causality	7-50
7-12	Summary	7-52

Chapter 8—Other Calibration Procedures

8-1	Overview of Other Calibration Procedures	8-1
8-2	Through (Thru) Update	8-1
8-3	Interpolation	8-2
8-4	Hybrid Calibrations	8-5
8-5	Secondary Match Correction	8-6

Chapter 9—Calibration and Measurement Enhancements

9-1	Chapter Overview	9-1
9-2	Embedding/De-embedding (E/DE)	9-3
	Embedding Tasks	9-3
	De-Embedding Tasks	9-3
	Embedding On/Off Control	9-4
	Types of E/DE Networks	9-7
	Entry Mode for Resistive Elements	9-8
	Entry Mode for Transmission Lines	9-9
	Entry Mode for S2P Defined File-Based Networks	9-10
	Saving and Recalling Embedding Network Configuration	9-11
9-3	Reference Plane Control	9-12
	Auto Button Functions	9-12
9-4	Impedance Transformation	9-14
9-5	Processing Order	9-16
	Reference Plane Processing Sequence	9-16
	Group Delay Processing Sequence	9-16
9-6	Conversions	9-17

Chapter 10—Verification

10-1	Introduction to Verification	10-1
------	--	------

Table of Contents (Continued)

10-2	Basic Concepts	10-1
	Hardware Level	10-1
	Intermediate System Level	10-1
	Comparison to Known Devices	10-1
	Metric of Comparison	10-2
	Verification Kit Creation Process	10-3
10-3	Verification Kit Components	10-4
	No Verification with Calibration Kits	10-4
10-4	Verification Kit Software	10-6
Chapter 11—Measurement Setup Requirements		
11-1	Chapter Overview	11-1
11-2	Channels and Traces Introduction	11-1
	Channel Concept	11-1
	Trace Concept	11-1
11-3	Measurement General Concepts	11-2
	Per-System Variables	11-2
11-4	Channels and the Channel Menu	11-3
11-5	Traces	11-6
	Per-Trace Variables	11-8
	Complex Trace Setup Example	11-9
11-6	Trace Math, Inter-trace Math, and Equation Editor	11-10
	Inter-trace Math	11-10
	Equation Editor	11-11
	Supported Complex Functions	11-13
11-7	Markers Overview	11-16
	Marker Button Label Changes	11-16
	Marker Unit Changes	11-16
	Reference Marker OFF or On	11-16
	Turning Individual Markers Off and On	11-16
	Turning All Markers On	11-16
	Turning All Markers Off	11-17
	Naming Conventions for Marker Buttons and Toolbars	11-17
	Position Marker(s)	11-17
11-8	Hold Functions	11-19
11-9	Overview of Limit Lines	11-20
11-10	Limit Lines	11-20
	Limit Test	11-20
	Test Result Sign	11-21
	Limit Line	11-21
	Limit Fail Signal	11-21
	Editing Limit Lines	11-21
	Edit Limit Line Menu	11-21
11-11	Ripple Limit Lines	11-23
	Response Menu	11-25

Table of Contents (Continued)

11-12 Averaging and Smoothing	11-26
Overview	11-26

Chapter 12—Measurement – Time Domain (Option 002)

12-1 Chapter Overview	12-1
12-2 Introduction	12-1
12-3 Basic Time Domain Modes	12-2
12-4 General Concepts	12-3
Chirp-Z Transform	12-3
Defects as Impulse Functions in the Time Domain	12-3
One-Way or Round Trip Time	12-3
12-5 Low Pass Mode	12-4
Range Setup Menu Functions	12-5
DC Term Menu	12-7
Window Shape Menu	12-8
12-6 Bandpass Mode	12-11
12-7 Gating	12-15
Gate Menu	12-15
DUT Example - Gate and Window Nominal	12-17
Other Frequency-with-time-gate Calculation Items	12-19
Saving Gated Results	12-21

Chapter 13—Measurement – Sweep Types

13-1 Chapter Overview	13-1
13-2 Introduction	13-1
13-3 Setting Up Traditional Frequency Sweeps (Linear and Log)	13-2
13-4 Maximum and Minimum Power Settings	13-2
13-5 Frequency-Based Segmented Sweep	13-3
13-6 Index-Based Segmented Sweep	13-7

Chapter 14—E/O and O/E Converter and Optical Measurements

14-1 Chapter Overview	14-1
14-2 Introduction and Background	14-2
Device Response	14-5
Optical Measurements Menu	14-7
14-3 Measurement Setups and Considerations	14-8
Optical Linearity	14-8
Laser Power and Photodetector Bias Sequencing	14-8
Optical Fiber Lengths	14-8
Modulator Bias Control	14-8
Connector Care	14-8
14-4 Example 2-Port Procedures	14-10
14-5 Uncertainties	14-17
14-6 Summary	14-17
14-7 References	14-18

Table of Contents (Continued)

Chapter 15—Maximum Efficiency Analysis (MEA) Measurements

15-1 Overview	15-1
15-2 Introduction	15-1
Software Setup for Maximum Efficiency Analysis	15-2

Chapter 16—MS46131A/ME7868A-Specific Topics

16-1 Overview	16-1
16-2 Background on the Architecture	16-1
16-3 High Isolation Mode and the LO-Generating Module	16-3
16-4 Phase Compensation	16-5
16-5 Gain Ranging	16-9

Appendix A—MS46131A 1-Port-Only Behavior

Index

Chapter 1 — Calibration Overview

1-1 Manual Scope

The purpose of this Measurement Guide is to introduce the basic calibration and operation of the ShockLine™ MS46122A/B, MS46131A, ME7868A, and MS46322A/B Series Vector Network Analyzer (VNA) and reduce the time required to become proficient at performing basic measurements. The procedures in this manual assume a working knowledge of, and a familiarity with, vector network analyzers.

This manual covers the following models:

- MS46122A/B-010, 1 MHz to 8 GHz, 2-Port
- MS46122A/B-020, 1 MHz to 20 GHz, 2-Port
- MS46122A/B-040, 1 MHz to 43.5 GHz, 2-Port
- MS46122B-043, 1 MHz to 43.5 GHz, 2-Port
- MS46131A-010, 1 MHz to 8 GHz, 1-Port
- MS46131A-020, 1 MHz to 20 GHz, 1-Port
- MS46131A-043, 1 MHz to 43.5 GHz, 1-Port
- MS46131A-012, 1-Port with PhaseLync
- ME7868A, 1 MHz to 43.5 GHz, 2-Port
- MS46322A-004, 1 MHz to 4 GHz, 2-Port
- MS46322A/B-010, 1 MHz to 8 GHz, 2-Port
- MS46322A-014, 1 MHz to 14 GHz, 2-Port
- MS46322A/B-020, 1 MHz to 20 GHz, 2-Port
- MS46322A-030, 1 MHz to 30 GHz, 2-Port
- MS46322A/B-040, 1 MHz to 43.5 GHz, 2-Port
- MS46322B-043, 1 MHz to 43.5 GHz, 2-Port

1-2 Chapter Summary

This chapter discusses general calibration requirements and the benefits of different calibration types, algorithms, and routines. General calibration setup and measurement procedures are described. Technical references to Anritsu and other calibration-related articles are also presented where appropriate. Some sections provide cross-references to more detailed explanations and procedures in subsequent chapters.

1-3 Related Documentation

The following ShockLine MS46121A/B, MS46122A/B, MS46131A, MS46322A/B Series VNA documentation is provided on the Anritsu website:

Product Information, Compliance, and Safety

- ShockLine Product Information, Compliance, and Safety (PICS) – 10100-00067

ShockLine MS46122A/B Vector Network Analyzers

- MS46122A Series VNA Technical Data Sheet – 11410-00822
- MS46122B Series VNA Technical Data Sheet – 11410-00995
- MS46122A/B Series VNA Operation Manual – 10410-00340
- MS46122A/B, MS46131A, ME7868A, MS46322A/B Series VNA Measurement Guide – 10410-00336

- MS46121A/B, MS46122A/B, MS46131A, MS46322A/B Series VNA ShockLine User Interface Reference Manual – 10410-00337
- ShockLine Programming Manual – 10410-00746
- MS46122A/B Series VNA Maintenance Manual – 10410-00341

ShockLine MS46131A Vector Network Analyzers

- MS46131A Series VNA Technical Data Sheet – 11410-011461
- MS46131A, ME7868A Series VNA Operation Manual – 10410-00780
- MS46122A/B, MS46131A, ME7868A, MS46322A/B Series VNA Measurement Guide – 10410-00336
- MS46121A/B, MS46122A/B, MS46131A, ME7868A, MS46322A/B Series VNA ShockLine User Interface Reference Manual – 10410-00337
- ShockLine Programming Manual – 10410-00746
- MS46131A Series VNA Maintenance Manual – 10410-00781

ShockLine MS46322A/B Vector Network Analyzers

- MS46322A Series VNA Technical Data Sheet – 11410-00751
- MS46322B Series VNA Technical Data Sheet – 11410-00996
- MS46322A/B Series VNA Operation Manual – 10410-00335
- MS46122A/B, MS46131A, MS46322A/B Series VNA Measurement Guide – 10410-00336
- MS46121A/B, MS46122A/B, MS46131A, ME7868A, MS46322A/B Series VNA ShockLine User Interface Reference Manual – 10410-00337
- ShockLine Programming Manual – 10410-00746
- MS46322A/B Series VNA Maintenance Manual – 10410-00342

Calibration, Verification, and System Performance Verification

- 3653A Mechanical Calibration Kit Reference Manual – 10410-00278
- Performance Verification Software (PVS) User Guide – 10410-00766
- PVS Quick Start Guide – 10410-00740

Calibration, Verification, and System Performance Verification

- MN25208A, MN25218A, MN25408A, MN25418A SmartCal Quick Start Guide – 10410-00741
- MN4765B O/E Calibration Module Technical Data Sheet (TDS) – 11410-00843
- MN4765B O/E Calibration Module Operation Manual (OM) – 10410-00742
- 36585K Precision Auto Calibrator (AutoCal™) Module Reference Manual – 10410-00279
- 3650A, 3652A, and 3654D Mechanical Calibration Kit Reference Manual – 10410-00278

1-4 Calibration Kits, Verification Kits, and Test Port Cables

Anritsu and other vendors provide calibration kits for a variety of algorithms and circumstances. In all cases, certain information must be provided to the VNA in order to complete the calibration, but the nature of that information varies by kit and application.

Calibration kits contain the precision components and tools required to calibrate the ShockLine MS46122A/B and MS46322A/B Series VNA for up to a complete 12-term error-corrected measurement. The calibration kits are available as automatic calibrator units or as manual calibration kits. A set of verification kits is also available to verify the accuracy of the calibration kits and the instrument settings.

Calibration/Verification Equipment Part Numbers and General Specifications

This table summarizes the equipment related to calibration procedures.

Table 1-1. Calibration Equipment Listing (1 of 3)

Part Number	Name	Specifications	Connectors
Precision AutoCal™ Modules			
36585K-2M	Precision AutoCal™ Module	70 kHz to 40 GHz	K(m) to K(m)
36585K-2F	Precision AutoCal Module	70 kHz to 40 GHz	K(f) to K(f)
36585K-2MF	Precision AutoCal Module	70 kHz to 40 GHz	K(m) to K(f)
36585V-2M	Precision AutoCal Module	70 kHz to 70 GHz,	V(m) to V(m)
36585V-2F	Precision AutoCal Module	70 kHz to 70 GHz,	V(f) to V(f)
36585V-2MF	Precision AutoCal Module	70 kHz to 70 GHz,	V(m) to V(f)
MN25208A	Precision 2-port SmartCal module	300 kHz to 8.5 GHz	Connector Options: -001 – N(f)
MN25408A	Precision 4-port SmartCal module	300 kHz to 8.5 GHz	-002 – K(f) -003 – 3.5 mm(f)
MN25218A ^a	Precision 2-port SmartCal module	300 kHz to 20 GHz	K(f)
MN25418A	Precision 4-port SmartCal module	300 kHz to 20 GHz	K(f)
Type N Connector Manual Calibration Kit			
3653A	Type N Calibration Kit With fixed loads	With fixed loads	Type N
OSLN50A-8	Precision Mechanical Calibration Tee	Open/Short/Load	N(m)
OSLNF50A-8	Precision Mechanical Calibration Tee	Open/Short/Load	N(f)
TOSLN50A-	Precision Mechanical Calibration Tee	Through/Open/Short/Load	N(m)
TOSLNF50A-8	Precision Mechanical Calibration Tee	Through/Open/Short/Load	N(f)
Type N Connector Manual Calibration Kit			
3653A	Type N Calibration Kit	With fixed loads	Type N
OSLN50A-8	Precision Mechanical Calibration Tee	Open/Short/Load	N(m)
OSLNF50A-8	Precision Mechanical Calibration Tee	Open/Short/Load	N(f)
TOSLN50A-8	Precision Mechanical Calibration Tee	Through/Open/Short/Load	N(m)
TOSLNF50A-8	Precision Mechanical Calibration Tee	Through/Open/Short/Load	N(f)

Table 1-1. Calibration Equipment Listing (2 of 3)

Part Number	Name	Specifications	Connectors
SMA Connector Manual Calibration Kits			
3650A	SMA/3.5 mm Calibration Kit	Without sliding loads	SMA/3.5 mm
3650A-1	SMA/3.5 mm Calibration Kit	With sliding loads	SMA/3.5 mm
K Connector Manual Calibration Kits			
3652A	K(2.92 mm) Calibration Kit	Without sliding loads	K
3652A-1	K(2.92 mm) Calibration Kit	With sliding loads	K
TOSLK50A-20	Precision Mechanical Calibration Tee	Through/Open/Short/Load	K(m)
TOSLK50A-20	Precision Mechanical Calibration Tee	Through/Open/Short/Load	K(f)
TOSLK50A-40	Precision Mechanical Calibration Tee	Through/Open/Short/Load	K(m)
TOSLK50A-40	Precision Mechanical Calibration Tee	Through/Open/Short/Load	K(f)
TOSLK50A-43.5	Precision Mechanical Calibration Tee	Through/Open/Short/Load	K(m)
TOSLK50A-43.5	Precision Mechanical Calibration Tee	Through/Open/Short/Load	K(f)
Verification Kits			
3663-2	Type N Connector Verification Kit	NIST traceable standards with two attenuators, an airline, and a stepped impedance airline Beatty Standard. Includes the Performance Verification Software application and related documentation.	
3666-2	3.5 mm/SMA Verification Kit		
Test Port Cables			
15KK50-1.0A	Test Port Cable, Armored, Phase Stable	1.0 m	K(m) to K(m)
15KKF50-1.0A	Test Port Cable, Armored, Phase Stable	1.0 m	K(m) to K(f)
15LL50-1.0A	Test Port Cable, Armored, Phase Stable	1.0 m	3.5 mm(m) to 3.5 mm(m)
15LLF50-1.0A	Test Port Cable, Armored, Phase Stable	1.0 m	3.5 mm(m) to 3.5 mm(f)
15NNF50-1.0B	Test Port Cable, Flexible, Phase Stable	1.0 m	N(f) to N(m)
15NNF50-1.5B	Test Port Cable, Flexible, Phase Stable	1.5 m	N(f) to N(m)
15NN50-1.0B	Test port Cable, Flexible, Phase Stable	1.0 m	N(m) to N(m)
3670K50A-1	Test Port Cable, Semi-rigid	0.3048 (1 ft)	K(f) to K(m)
3670K50A-2	Test Port Cable, Semi-rigid	0.6096 (2 ft)	K(f) to K(m)
3671KFS50-60	Test Port Cables, Flexible, High Performance	1 each, 63.5 cm (25 in)	K (f) to 3.5 mm (m)
3671KFK50-60	Test Port Cables, Flexible, High Performance	1 each, 63.5 cm (25 in)	K (f) to K (m)
3671KFKF50-60	Test Port Cables, Flexible, High Performance	1 each, 63.5 cm (25 in)	K (f) to K (f)

Table 1-1. Calibration Equipment Listing (3 of 3)

Part Number	Name	Specifications	Connectors
3671KFK50-100	Test port cables, flexible, high performance	1 each, 96.5 cm (38 in)	K (f) to K (m)
Universal Test Fixtures (UTF) and Right Angle Launchers			
3680-20	UTF	DC to 20 GHz 0.5 cm (min) to 10 cm (max)	3.5 mm (f) to (f)
3680K	UTF	DC to 40 GHz 0.5 cm (min) to 5 cm (max)	K(f) to K(f)
36801K	Right Angle Launcher	DC to 40 GHz 1 cm (min) to 4 cm max	

a. Applies to Rev 2 SmartCal Modules. MN25218A with serial numbers <1817999 operate from 1 MHz to 20 GHz.

1-5 AutoCal Automatic Calibration Modules

The auto calibration process represents both a calibration kit and an algorithm that can be used to speed up the calibration process with extremely high accuracy and a minimal number of manual steps.

The SmartCal™ module is a plug and play device that automatically powers on and loads calibration coefficients from its on-board memory into ShockLine software. SmartCal has auto sense and port mapping features, allowing it to auto sense the VNA port number to which it is connected. In addition, port mapping allows the user to assign any SmartCal port to any of the VNA ports.

The 36585K Calibration module calibrates the VNA by a process known as “transfer calibration.” There are a number of impedance and transmission states in the module designed to be extremely stable in time and these states are carefully “characterized,” generally by the Anritsu factory but also in a customer laboratory in certain cases. When the same states are re-measured during an actual calibration, and the results compared to the characterization data, an accurate picture can be generated of the behaviors and error terms of the VNA and setup being calibrated.

A very high calibration accuracy is maintained through the use of certain principles:

- The use of many impedance and transmission states.
- The creation of very stable states that are further enhanced with a constant-temperature thermal platform inside the module.
- The use of very reliable and repeatable solid-state switching constructed to provide a great variety of state impedances (for better calibration stability) and clean transmission paths.
- The use of a very careful characterization process that can generate excellent starting data.

The resulting accuracy can exceed that obtained with a typical mechanical calibration performed in a laboratory. The Calibration results may not be better than that of an exotic manual calibration (such as is performed during factory characterization) but will be far better than that done typically. Since it is a very high performance calibration, connector care is of the utmost importance and is discussed in detail later in this chapter.

The AutoCal consists of the calibration module itself, a separate external power supply, a serial control cable that runs to the VNA, and the characterization data provided on a USB memory device. Serial to USB adapter (2000-1809-R) is also required for operating the AutoCal module on the MS46322A/B and MS46122A/B VNAs.

Calibrations Available

Of the various calibration types described for the instrument, most are available with the Calibration unit. Frequency response calibrations are omitted since the Calibration unit would provide no benefit in these cases (since only a through or high reflect standard is needed for these calibrations). Available calibrations include:

- Full 2-Port calibration
- Reflection only (full 1-Port calibration); either port or both can be specified
- 1-Path 2-Port (1p2p); either direction can be specified (i.e., calibrate S_{11} and S_{21} or calibrate S_{22} and S_{12})

1-6 SOLT/SOLR Kits (365xx)

This kit, based on short-open-load-through, requires data describing all of the reflection standards (provided by the factory) be loaded into the instrument on a serial number basis. If this media (a USB key) is not available, average default coefficients are available within the VNA that may suffice for some measurements.

Typically these calibration kits are loaded using the CAL KIT menu (Figure 1-1) but user-defined kits can also be created using the parameters described above. If calibration kits from another manufacturer are used or to create a calibration kit, the following parameters are typically entered into one of the user-defined kits:

- Open definition (M and F typically)
- Short definition (M and F typically)
- Load definition (M and F typically)

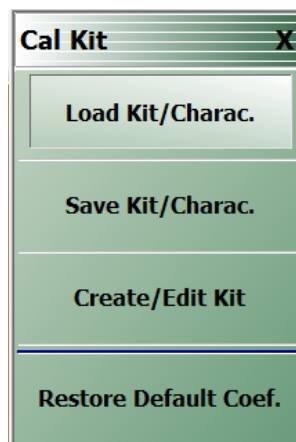

Figure 1-1. CAL KIT Menu

The CAL KIT menu is shown Figure 1-1. This menu allows calibration kit details to be loaded from external files (as provided with Anritsu calibration kits), saved to a file (for user-defined cal kits), defaulted (for standard connector types), or simply displayed.

1-7 Offset Short Waveguide Kits (3655X)

Waveguide calibration kits based on offset short calibrations are also provided for different waveguide bands. Here two different offset-length shorts (accomplished with flush shorts and two different insert lengths), loads, and a through must be specified. Some of the standard kits are pre-defined and user-defined kits are possible as usual. Additional pieces of information here due to line type are the cutoff frequency and dielectric constant. Items as part of the definition:

- Load definition
- Short 1 definition
- Short 2 definition
- Waveguide cutoff frequency

1-8 Microstrip/Coplanar Waveguide Kits for the UTF (36804-XXX)

For certain microstrip and coplanar waveguide measurements, the Universal Test Fixture (UTF) can accommodate a range of substrate sizes and thicknesses (see 3680 brochure for more information). The 36804 series of calibration kits provide opens, shorts, loads and a variety of transmission line lengths on alumina that can be used for different calibration algorithms. User-defined kits must be generated based on the information provided with the kits.

1-9 Calibration Algorithms

The ShockLine MS46122A/B, MS46322A/B, and ME7868A provide for the following calibration methods:

- Short-Open-Load-Through (SOLT) with Fixed or Sliding Load
- Short-Open-Load-Reciprocal (SOLR) – “B” models only.
- Reciprocal or Unknown Through Method – “B” and ME7868A models only.
- Offset Short (SSLT) Calibration
- Triple Offset Short (SSST) Calibration
- Line-Reflect-Line (LRL) / Line-Reflect-Match (LRM) AutoCal – “B” and ME7868A models only.
- Adapter Removal Calibration
- AutoCal™
- SmartCal

The ShockLine MS46131A provides for the following 1-port calibration methods:

- Short-Open-Load (SOL)
- Offset Short (SSL) Calibration
- Triple Offset Short (SSS) Calibration
- Adapter Removal Calibration
- AutoCal
- SmartCal

1-10 About Calibration

The most important central concept to making good VNA S-parameter measurements is the calibration of the instrument. The background on calibration mathematics and theory will only be lightly covered in this section; more information is available in Anritsu Application Notes and in the reference literature. While the VNA is a highly linear receiver and has sufficient spectral purity in its sources to make good measurements, there are a number of imperfections that limit measurements done without calibrations:

Match

Because the VNA is such a broadband instrument, the raw match can be good but not excellent. Even a 20 dB match, which is physically very good, can lead to errors of greater than 1 dB. By correcting for this raw match, the potential error can be greatly reduced.

Directivity

A key component of a VNA is a directional coupler that allows separation of the signal incident on the DUT from the signal reflected back from the DUT. While the couplers used in the VNA are of very high quality, there is an amount of coupled signal even when a perfect termination is connected. This is related to directivity and can impact measurements of very small reflection coefficients.

Frequency Response

While the internal frequency response of the VNA could be calibrated at the factory, any cables connected externally will have some frequency response that must be calibrated out for high quality measurements.

The calibration is a method of correcting for these and other defects. There are an enormous number of possible calibration algorithms and many of them are implemented within the MS46122A/B and MS46322A/B VNAs. The choice between them is largely determined by the media used, the calibration standards available, and the desired accuracy/effort trade-off. Some of the choices to be made are:

- **Calibration Type**

Which ports are being corrected and to what level are they being corrected?

- **Calibration Algorithm**

How is the correction being accomplished?

Calibration Types

Table 1-2. MS46122A/B and MS46322A/B Calibration Types^a

VNA Mode	Type	Parameters Calibrated	Uses
2-Port VNA Mode	Full 2 Port	S_{11} , S_{12} , S_{21} , and S_{22}	Most complete calibration
	Full 1 Port	S_{11} or S_{22}	Reflection calibration only
	1 Path 2 Port	S_{11} and S_{21} or S_{22} and S_{12}	1 port reflection plus simple transmission (faster, lower transmission accuracy unless DUT very lossy)
	Frequency Response	Any one parameter (or pairs of symmetric parameters such as S_{12} and S_{21})	Normalization only. Fast, lower accuracy

a. MS46131A only supports full 1 port or reflection frequency response calibrations.

Calibration Algorithms

The use of acronyms for the various calibration algorithms is often inconsistent. The following table presents calibration algorithm acronyms as used in Anritsu documentation.

Table 1-3. Calibration Algorithms

Calibration Algorithm	Description	Advantages	Disadvantages
SOLT (Short-Open-Load-Through)	Common coaxially	Simple, redundant standards; not band-limited	Requires very well-defined standards, poor on-wafer, lower accuracy at high frequencies
SSLT (Short-Short-Load-Through, also called Offset Short), shorts with different offset lengths	Common in Waveguide	Same as SOLT	Same as SOLT and band limited
SSST (Short-Short-Short-Through, also called Triple Offset Short), all shorts with different offset lengths	Common in waveguide or high frequency coax	Same as SOLT but better accuracy at high frequencies	Requires very well-defined stds, poor on-wafer, band-limited
SOLR, like above but with "Reciprocal" instead of "Through." Available with the "B" models only.	Like the above but when a good through is not available	Does not require well-defined through	Some accuracy degradation but slightly less definition, other disadvantages of parent cal
LRL (Line-Reflect-Line, also called Through-Reflect-Line or TRL). Available with the "B" models only.	High performance coax, waveguide or on-wafer	Highest accuracy, minimal standard definition	Requires very good transmission lines, less redundancy so more care is required, band-limited

The following table relates the Calibration Types to the Calibration Algorithms.

Table 1-4. Calibration Types and Calibration Algorithms

VNA Mode	Type	SOLT	SSLT	SSST	SOLR/SSLR/SSSR "B" models	LRL "B" models
2-Port Mode	Full 2 Port	YES	YES	YES	Yes	Yes
	Full 1 Port	YES	YES	YES	Yes—Can be selected for these types, but the reciprocal nature is not used and will function like the base calibration	-
	1 Path 2 Port	YES	YES	YES		-
	Frequency Response	YES	YES	YES		-

1-11 Calibration Setup

Before proceeding to the calibrations and some of the alternatives available, there are certain instrument setup issues that must be discussed first since they will affect the performance of all calibrations. In almost all cases, the current VNA settings will be used during the calibration, so setting up the VNA as desired beforehand will help.

Frequency Start, Stop, and Number of Points

The Start Frequency, Stop Frequency, and number of points should be decided and set in the VNA before performing a calibration. Segmented sweeps should also be set up in advance if a more custom frequency list is desired.

IF Bandwidth, Averaging, and Power

These parameters control the digital filtering and post-processing that determine the effective noise floor, the amount of trace noise and, in some special cases, the immunity to interfering signals. The trade-off for improved noise performance is slower sweep speed.

- **IF Bandwidth (IFBW)**

Settings of 10 Hz to 300 kHz on the MS46122A/B and MS46322A/B are allowed with the RMS trace noise ranging from < 6 m dB at the low end to a few hundred m dB at the high end (for high level signals, more for lower level signals).

- **Point-by-Point vs. Sweep-by-Sweep Averaging**

- Point-by-Point averaging incurs additional measurements at each given frequency point and will increase sweep time roughly proportionally. Because the additional measurements are taken at once, the effect is similar to proportional change in IFBW.
- Sweep-by-sweep averaging acquires additional measurements on subsequent sweeps and is better at removing lower frequency variations than point-by-point averaging or IFBW reduction. Sweep-by-sweep averaging is a rolling average so the time to fully stabilize from a sudden DUT change is roughly proportional to the average count.

- **Power**

Port power is somewhat less critical because of the excellent linearity of the MS46122A/B and MS46322A/B VNA receivers.

1-12 Types of Calibrations

The types of calibrations are defined by what ports are involved and what level of correction is accomplished (see [Table 1-2, “MS46122A/B and MS46322A/B Calibration Types” on page 1-9](#)).

Full 2 Port

This is the most commonly used and most complete calibration involving two ports. All four S-parameters (S_{11} , S_{12} , S_{21} , and S_{22}) are fully corrected.

Full 1 Port

A single reflection parameter is fully corrected in this case (S_{11} or S_{22}). Both ports can be covered but only reflection measurements will be corrected. This calibration type is useful for reflection-only measurements including the possibility of doing two reflection-only measurements at the same time. 1-Port calibrations are the only calibrations currently supported on the MS46131A.

1 Path 2 Port (Forward or Reverse)

In this case, reflection measurements on one port are corrected and one transmission path is partially corrected (load match is not). Here forward means S_{11} and S_{21} are covered while reverse means S_{12} and S_{22} are covered. This technique may be used when speed is at a premium, only two S-parameters are needed and either the accuracy requirements on the transmission parameter are low or the DUT is very lossy ($\cong >10\text{-}20$ dB insertion loss).

Frequency Response (Reflection Response and Transmission Frequency Response)

This calibration is essentially a normalization and partially corrects one parameter (although two can be covered within the cal menus). Only the frequency response, or tracking slope, of the parameter is corrected so directivity and match behaviors are not taken into account. This technique is valuable when accuracy requirements are not at a premium and a quick measurement is all that is needed.

Each of these calibrations has an associated error model that describes what is being corrected. The error coefficients used fall into several categories that roughly describe the physical effect that they are responsible for correcting. To establish a context for these error terms, consider the usual model where all of the VNA/setup errors are lumped into error boxes (that act like S-parameters) between a perfect VNA and the DUT reference planes (see [Figure 1-2 on page 1-12](#)).

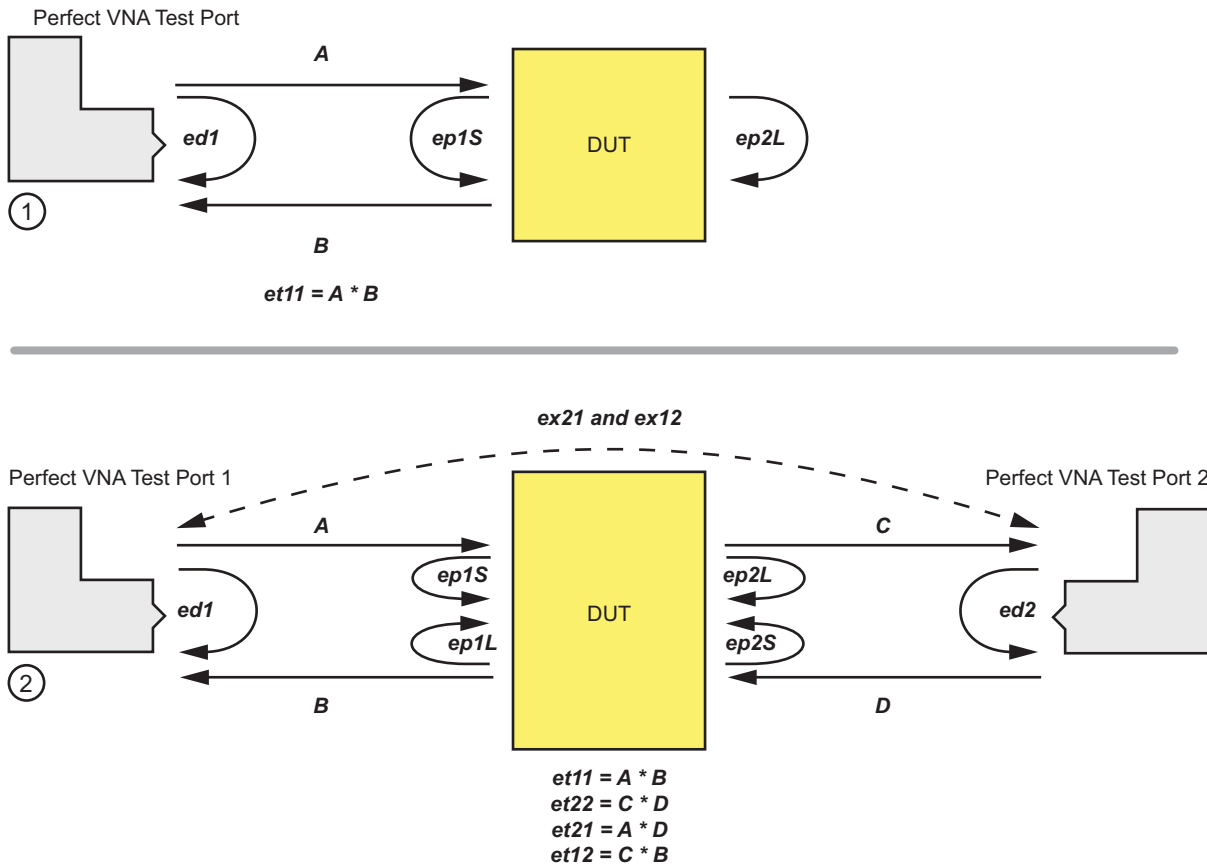

1. At top, a classic One-Port Error Model. 2. At bottom, a classic Two-Port Error Model

Figure 1-2. Classic One- and Two-Port Error Models

Two slightly different error models are used: one where each port is considered to be driving separately (so one can clearly delineate source match from load match) and one where both ports are present and no driving distinction is made (requiring some preprocessing to take care of source match-load match differences).

- **Directivity**
Directivity ($ed1$ and $ed2$) describes the finite directivity of the bridges or directional couplers in the system. Partially includes some internal mismatch mechanisms that contribute to effective directivity.
- **Source Match**
Source match ($ep1S$ and $ep2S$) describes the return loss of a driving port.
- **Load Match**
Load match ($ep1L$ and $ep2L$) describes the return loss of a terminating port.
- **Reflection Tracking**
Reflection tracking ($et11$ and $et22$) describes the frequency response of a reflect measurement including loss behaviors due to the couplers, transmission lines, converters, and other components.
- **Transmission Tracking**
Transmission tracking ($et12$ and $et21$) is the same as above but for the transmission paths. The tracking terms are not entirely independent and this fact is used in some of the calibration algorithms.

- **Isolation**

Isolation (ex12 and ex21) takes into account certain types of internal (non-DUT dependent) leakages that may be present in hardware. It is largely present for legacy reasons and is rarely used in practice since this type of leakage is typically very small in modern VNAs.

1-13 Line Types (Transmission Media)

Part of the calibration definition is the selection of line type. The main purpose of this is to assign a dispersion characteristic that will be needed later. Dispersion is the dependence of the phase velocity on the line with frequency. Media such as coax and coplanar waveguides are largely dispersion-free; that is, we can define phase velocity by a single number:

$$v_{\text{ph}} = \frac{c}{\sqrt{\epsilon_r}}$$

= phase velocity for coaxial and non-dispersive media

Equation 1-1

Where:

- c is the speed of light in a vacuum (~2.9978108 m/s) and
- ϵ_r is the relative permittivity of the medium involved.

Coaxial cable has its own selection since it is intrinsic to the instrument while other non-dispersive media can be selected separately.

One type of dispersive media is regular waveguide. The phase velocity here is defined by:

$$v_{\text{ph}} = \frac{c}{\sqrt{\epsilon_r} \times \sqrt{1 - \left(\frac{f_c}{f}\right)^2}}$$

$$= \frac{c}{\sqrt{\epsilon_r - \left(\frac{f_{c0}}{f}\right)^2}}$$

= phase velocity for waveguide

Equation 1-2

Where:

- ϵ_r is the dielectric constant
- f_c is the cutoff frequency of the waveguide (with dielectric) and
- f_{c0} is the cutoff frequency of the waveguide in a vacuum (which is what is entered).

The system will compute the required values. This information is needed for computing distances when in time domain and when adjusting reference planes.

Microstrip lines are another example of dispersive media that can be selected. Here the dimensions of the line together with the dielectric material determine the phase velocity behavior. An intermediate quantity, called the effective dielectric constant ($S_{r,\text{eff}}$), is used and a suggested value computed by the VNA but this value can be overridden. At low frequencies, the structure can be considered non-dispersive (like coax) with a phase velocity given by:

$$v_{\text{ph}} = \frac{c}{\sqrt{\epsilon_{r, \text{eff}}}}$$

= low frequency limit

Equation 1-3

At higher frequencies when additional mode behavior becomes important, dispersion must be handled. The dielectric constants (media-based and effective) together with a transition frequency f_t are used to compute this effect, which is heavily dependent on the dielectric thickness:

$$v_{\text{ph}} = \frac{c}{\sqrt{\frac{\epsilon_{r, \text{eff}} + \epsilon_r \cdot \left(\frac{f}{f_t}\right)^2}{1 + \left(\frac{f}{f_t}\right)^2}}} \quad \text{where} \quad f_t = \frac{Z_{c0} \sqrt{\epsilon_r} c^2}{2t \sqrt{\epsilon_{r, \text{eff}}}}$$

Equation 1-4

Where:

- Z_c is the characteristic impedance of the microstrip line
- t is the dielectric thickness

1-14 Connector Precautions

Pin Depth

Before mating, measure the pin depth (Figure 1-3) of the device that will mate with the RF component, using an **Anritsu Pin Depth Gauge** or equivalent (Figure 1-4). Based on RF components returned for repair, destructive pin depth of mating connectors is the major cause of failure in the field. When an RF component is mated with a connector having a destructive pin depth, damage will likely occur to the RF component connector. (A destructive pin depth has a center pin that is too long with respect to the reference plane of the connector.)

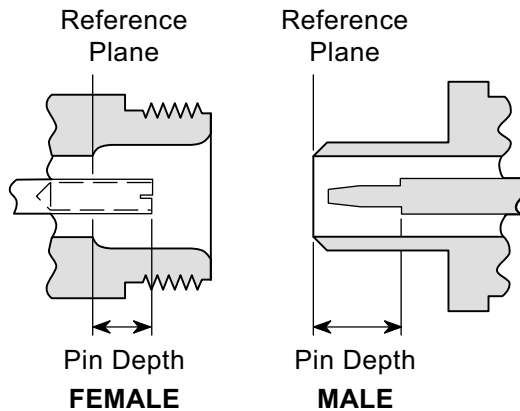
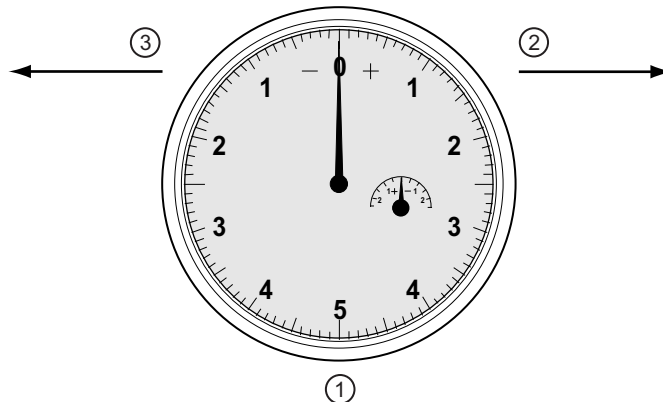

Figure 1-3. N Connector Pin Depth

Pin Depth Tolerance

The center pin of RF component connectors has a precision tolerance measured in mils (1/1000 inch). Connectors on test devices that mate with RF components may not be precision types and may not have the proper depth. They must be measured before mating to ensure suitability. When gauging pin depth, if the test device connector measures out of tolerance as listed in Table 1-5, “Pin Depth Tolerances” on page 1-16 in the “+” region of the gauge (Figure 1-4), the center pin is too long. Mating under this condition will likely damage the termination connector.



Index	Description
1	Pin Depth Gauge with needle setting at zero.
2	Positive needle direction clockwise to right.
3	Negative needle direction counter-clockwise to left.

Figure 1-4. Pin Depth Gauge

On the other hand, if the test device connector measures out of tolerance in the “–” region, the center pin is too short. While this will not cause any damage, it will result in a poor connection and a consequent degradation in performance.

Table 1-5. Pin Depth Tolerances

Connector Type	Pin Depth (Inch)	Pin Depth (mm)
7/16 Male	+0.0579	+1.47
	+0.0697	+1.77
7/16 Female	–0.0697	–1.77
	–0.0815	–2.07
GPC-7	+0.000	+0.000
	–0.003	–0.076
N Male	–0.207	– 5.258
	–0.210	–5.334
N Female	+0.207	+5.258
	+0.204	+5.182
WSMA Male (3.5 mm)	–0.0025	–0.0635
WSMA Female (3.5 mm)	–0.0035	–0.0889
K Male (2.92 mm)	+0.000	+0.000
K Female (2.92 mm)	–0.0050	–0.127

Over-Torquing Connectors

Over torquing connectors is destructive; it may damage the connector center pin. Finger-tight is usually sufficient, especially on Type N connectors.

Caution Never use pliers to tighten connectors.

Teflon Tuning Washers

The center conductor on most RF components contains a small Teflon tuning washer located near the point of mating (interface). This washer compensates for minor impedance discontinuities at the interface. The location of the washer is critical to the performance of the RF components.

Caution Do not disturb the Teflon tuning washer in connectors.

Mechanical Shock

RF components are designed to withstand years of normal bench handling. However, do not drop or otherwise treat them roughly. They are laboratory-quality devices, and like other such devices, they require careful handling.

1-15 Connector Cleaning Instructions

To prevent unnecessary early failure and inaccurate measurements, connector interfaces must be kept clean and free of dirt and other debris. With repeated connections and disconnections, the threads and outer conductor mating interface builds up a layer of dirt and metal chips which can severely degrade connector electrical and mechanical performance. This debris can also increase the coupling torque required for a good connection which can then damage the mating interfaces. See the *RF and Microwave Connector Care Reference Manual*, 10100-00031.

Caution Use the correct-sized cotton swabs that are made specifically for cleaning small areas. Oversized cotton swabs can put lateral pressure on the center pin and damage it. Be sure that no cotton strands get caught in the connector.

Required Cleaning Items

- Low-pressure dry, compressed air (oil free, solvent free), maximum pressure: 40 PSI,
- Lint-free cotton swabs
- Isopropyl alcohol (IPA), 90 %
- Microscope

Caution Do not use compressed air on power sensors. Some power sensors have components internally located near the connector that can be damaged from excessive air pressure.

Teflon Tuning Washers

Note

The center conductor on some RF components contains a small Teflon tuning washer located near the point of mating (interface). This washer compensates for minor impedance discontinuities at the interface. The washer's location is critical to the RF component's performance. Be careful not to disturb it with a cotton swab or compressed air and don't apply alcohol to it.

Cleaning Procedure

Do not use industrial solvents or water to clean the connector. Use 90 % Isopropyl Alcohol (IPA) only.

Caution Do not spray alcohol directly onto connector surfaces.

Do not saturate the swab with alcohol. Instead, lightly dampen it by touching the tip onto a bead of alcohol formed at the bottle tip as shown.

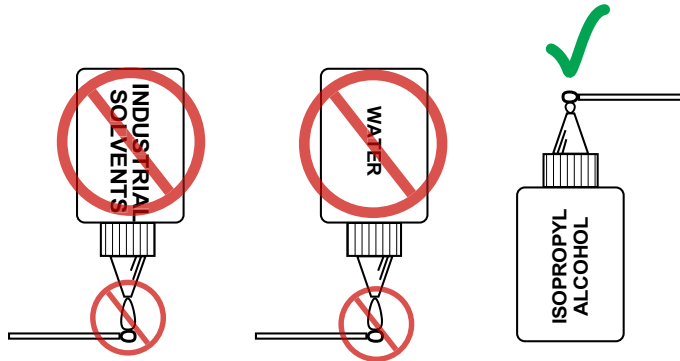

Figure 1-5. Isopropyl Alcohol Only

1. Remove loose particles on the mating surfaces, threads, and similar surfaces using low-pressure (42 PSI max) compressed air applied at a shallow angle so dirt is not forced down into the connector.

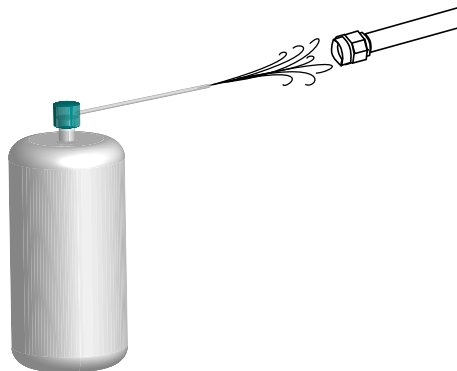

Figure 1-6. Low Pressure Compressed Air Cleaning

2. Clean the threads of the connector with a lint-free cotton swab dampened with IPA.

Caution Do not insert cotton swabs at an angle. Doing so can damage the center pin. Do not use a cotton swab that is too large. It can stress and damage the center pin.

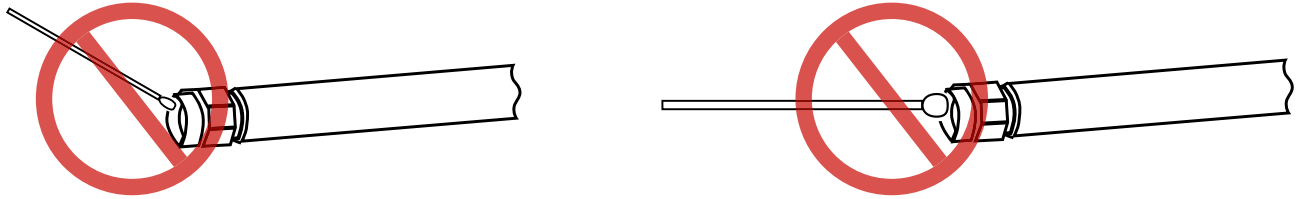

Figure 1-7. Avoid Angled or Large Swab

3. Clean the mating plane surfaces and connector threads by gently moving the cotton swab around the center pin. Do *not* touch the center pin.

When the connector is clean, you should be able to hand tighten the connector to within approximately one half turn of the specified torque.

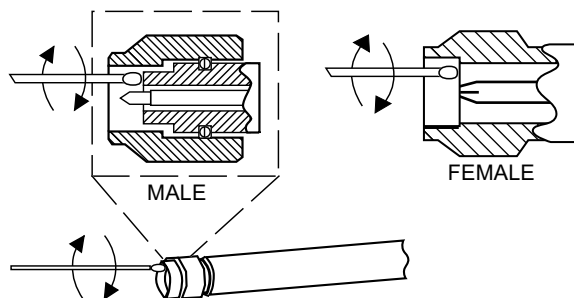

Figure 1-8. Cleaning Connector with Cotton Swabs

4. After cleaning with swabs, again use low-pressure compressed air to remove any remaining small particles and dry the connector surfaces.

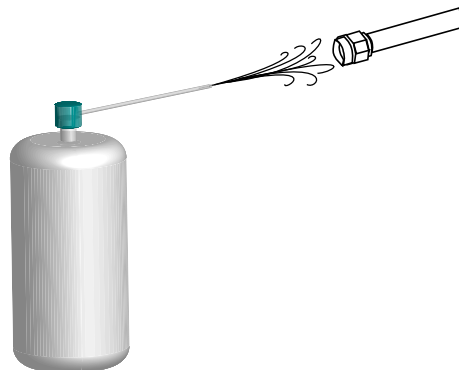

Figure 1-9. Compressed Air Drying

5. With the aid of magnification and adequate lighting, inspect the connectors for damage, cotton strands or other debris.

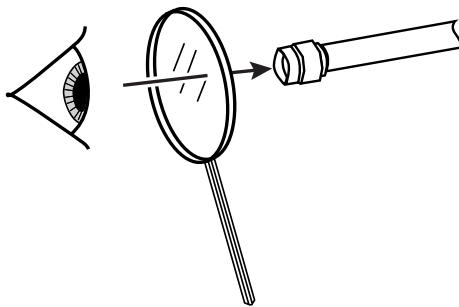

Figure 1-10. Final Inspection

Chapter 2 — Automatic Calibration Procedures

2-1 Chapter Overview

This chapter describes common procedures for both Internal Through and True-Through calibration using Anritsu the 36585-Series Precision AutoCal Modules and the SmartCal Modules. This chapter provides two examples of using a precision adapter with an AutoCal or SmartCal unit to create a different-gender reference plane with adapter removal.

Note	The MS46122A/B requires a PC Controller to operate the MS46122A/B VNA and the Calibrator Modules. Detailed setup descriptions in this chapter start at “MS46122A/B Typical Calibrator Connections” on page 2-8.
-------------	---

2-2 Automatic Calibration Introduction

Note	In some menus and screens, S11 is used to represent the S_{11} calibration parameter, S12 for S_{12} , S21 for S_{21} , and S22 for S_{22} , and so on.
-------------	---

The auto calibration process represents both a calibration kit and an algorithm that is used to speed up the calibration process with extremely high accuracy, minimizing the number of manual steps and test operator involvement.

Transfer Calibration

The 36585x-Series Precision AutoCal and the SmartCal Module calibrates the VNA by a process known as “transfer calibration.” There are a number of impedance and transmission states in the module designed to be extremely stable in time and these states are carefully “characterized”, generally by the Anritsu factory but also in a customer laboratory in certain cases.

When the same states are re-measured during a calibration, and the results compared to the characterization data, an accurate picture can be generated of the behaviors and error terms of the VNA and setup being calibrated.

Calibration Accuracy

A very high calibration accuracy is maintained through the use of certain principles

- The use of many impedance and transmission states
- The creation of very stable states that are further enhanced with a constant-temperature thermal platform inside the module.
- The use of very reliable and repeatable solid-state switching constructed to provide a great variety of state impedances (for better calibration stability) and clean transmission paths.
- The use of a very careful characterization process that can generate excellent starting data.

The resulting accuracy can exceed that obtained with typical mechanical calibration typically performed in a metrology laboratory. The automatic calibration results may not be better than that of an calibration performed during factory characterization, but is far better than that typically done.

2-3 Automatic Calibration Terms

This section defines various terms used with SmartCal and AutoCal calibration modules and procedures used with the ShockLine VNA.

Note	Because in many cases, either module can be utilized using the same setups described in this chapter, they are referred to as Calibration Modules or Calibrators.
-------------	---

Insertable and Non-Insertable Devices

Insertable devices have an insertable connector pair such as a male input connector and a female output connector. These devices can be measured after a through calibration. A non-insertable device has a non-insertable pair of connectors such as female connectors on both ports or different connector types such as a DUT with both a N and K connector. Non-insertables cannot be connected directly into the measurement path without an adapter.

- **Through (“Thru”)**

A *thru* (properly called a “through”) is a connection of the two test ports. Two kinds of through connections, internal through and true through, are defined for the calibration.

- **Internal Through (“Internal Thru”)**

An Internal Through is an internal path through the calibrator requiring no operator involvement in the Calibration Module setup.

- **True Through (“True Thru”)**

A True Through is a direct cable connection between the test ports, with no intervening connectors. A true through is more accurate than an internal through, but requires more operator involvement and takes more time to accomplish. The true through can be more accurate than the internal through (if very well-matched and of very low loss) but the length and loss must be entered. The return loss of the adapters must be very good to avoid added error.

Auto-Sense

- **AutoCal Module**

A selectable function of the AutoCal module where, if enabled, the AutoCal module decides the left/right test cable assignment. If not enabled, the operator defines the port number to left/right assignment.

- **SmartCal Module**

A selectable function of the SmartCal module where, if enabled, the SmartCal module decides the A/B test cable assignment. If not enabled, the operator defines the port number to A/B assignment.

Characterization File

Each calibrator module has a file containing data that characterizes each standard in the calibrator. This file also contains information (identification number, start and stop frequencies) concerning the capabilities of the calibrator. Each characterization file has the extension “.acd.”

When AutoCal modules are changed, the appropriate new characterization file must be installed. The files are typically stored on a Characterization Memory Device (USB memory device). Insert the Characterization Memory Device into a VNA USB port. This file can be installed by navigating to the LOAD (AutoCal Characterization/Cal Kit) dialog box shown in [Figure 2-1](#).

- MAIN MENU | Calibration | CALIBRATE | Cal. Kit Options | LOAD KIT / CHARAC. |

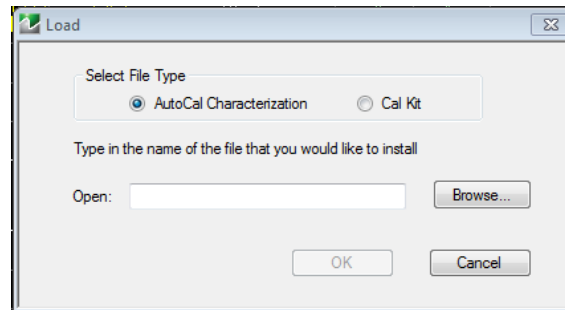

Figure 2-1. Load CalKit Dialog Box

From the dialog box, navigate to the location of the Characterization Memory Device. Select the file and click OK to load it into memory. If desired, the user can copy a characterization file from the USB stick onto the hard drive of the VNA computer. In addition, each calibration module can be re-characterized using the VNA, although specifications are only valid if Anritsu has performed the characterization (recommended re-characterization interval is 12 months). A valid 12-term calibration must be active, which is used to characterize the standards within the module.

Note that when SmartCal modules are changed, there is no need for installing characterization files because all calibration data needed for the SmartCal is located in the SmartCal memory. Simply connect the SmartCal module and it is ready.

2-4 Available Calibrator Modules and Adapters

The two series of auto-calibration units available are the SmartCal and AutoCal modules. Examples are shown in [Figure 2-2](#)



1. MN25418A SmartCal Module

2. 36585V AutoCal Module

Figure 2-2. Example SmartCal and AutoCal

AutoCal Modules and Adapters

The table below shows the available AutoCal modules.

Table 2-1. Precision and Standard AutoCal Kits and Adapters

Part Number	Name	Frequency Range and Connectors
Precision AutoCal Kits		
36585K and 36585V Series Precision AutoCal Modules can be used with ShockLine VNAs with adapters. The calibration range is limited to that of the VNA.		
36585K-2M	Precision AutoCal Kit, K(m-m), 2-Port	70 kHz to 40 GHz, K(m) to K(m)
36585K-2F	Precision AutoCal Kit, K(f-f), 2-Port	70 kHz to 40 GHz, K(f) to K(f)
36585K-2MF	Precision AutoCal Kit, K(m-f), 2-Port	70 kHz to 40 GHz, K(m) to K(f)
36585V-2M	Precision AutoCal Kit, V(m-m), 2-Port	70 kHz to 70 GHz, V(m) to V(m)
36585V-2F	Precision AutoCal Kit, V(f-f), 2-Port	70 kHz to 70 GHz, V(f) to V(f)
36585V-2MF	Precision AutoCal Kit, V(m-f), 2-Port	70 kHz to 70 GHz, V(m) to V(f)

SmartCal Modules and Adapters

The table below shows the available SmartCal modules.

Table 2-2. Precision and Standard SmartCal Kits and Adapters

Part Number	Name	Frequency Range and Connectors
Precision AutoCal Kits		
MN252x8A and MN254x8A-Series Precision SmartCal Modules can be used with ShockLine VNAs with adapters. The calibration range is limited to that of the VNA.		
MN25208A-001	SmartCal Automatic Calibration Unit, N(f), 2-Port	300 kHz to 8.5 GHz, all ports – N(f)
MN25208A-002	SmartCal Automatic Calibration Unit, K(f), 2-Port	300 kHz to 8.5 GHz, all ports – K(f)
MN25208A-003	SmartCal Automatic Calibration Unit, 3.5 mm(f), 2-Port	300 kHz to 8.5 GHz, all ports – 3.5 mm(f)
MN25218A-002 ^a	SmartCal Automatic Calibration Unit, K(f), 2-Port	300 kHz to 20 GHz, all ports – K(f)
MN25408A-001	SmartCal Automatic Calibration Unit, N(f), 4-Port	300 kHz to 8.5 GHz, all ports – N(f)
MN25408A-002	SmartCal Automatic Calibration Unit, K(f), 4-Port	300 kHz to 8.5 GHz, all ports – K(f)
MN25408A-003	SmartCal Automatic Calibration Unit, 3.5 mm(f), 4-Port	300 kHz to 8.5 GHz, all ports – 3.5 mm(f)
MN25418A-002	SmartCal Automatic Calibration Unit, K(f), 4-Port	300 kHz to 20 GHz, all ports – K(f)

a. Applies to Rev 2 SmartCal Modules. MN25218A with serial numbers <1817999 operate from 1 MHz to 20 GHz.

AutoCal Components

The AutoCal unit consists of the Calibrator Module itself, a separate external power supply, a control cable that runs to the VNA, and the characterization data that is initially provided on a USB memory device. The AutoCal unit should be powered up and allowed to warm up prior to use (typically a few minutes; the blue Operate LED will illuminate when the unit is at temperature). Allow 90 minutes warm-up time for calibrations. The control cable should be connected to the serial port on the back of the VNA to USB adapter (Anritsu part number 2000-1809-R) with the USB connector attached to the VNA.

SmartCal Module

The SmartCal module is a plug and play device that automatically powers on and loads calibration coefficients from its on-board memory into the ShockLine software. SmartCal has auto sense and port mapping features, allowing it to auto sense the VNA port number to which it is connected. In addition, port mapping allows the user to assign any SmartCal port to any of the VNA ports.

Connector Care

Since an automatic calibration is a very high performance calibration, connector care is of the utmost importance. See [Figure 1-14, “Connector Precautions” on page 1-15](#)

Calibration Parameters and Types

The AutoCal and SmartCal require four general parameters be defined, as shown in the dialog box: [Figure 2-3](#)

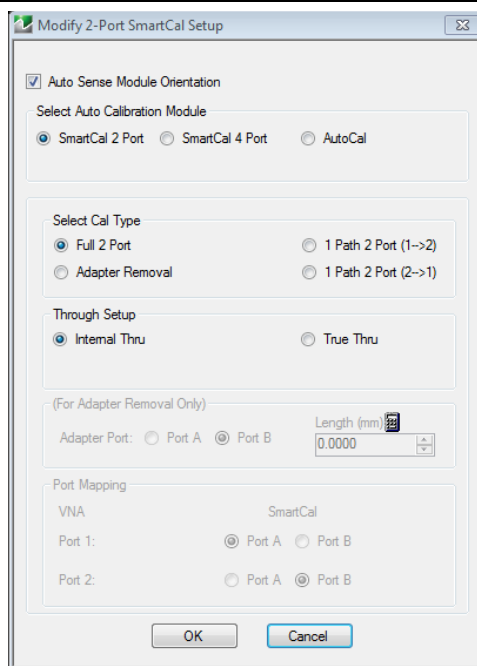

Figure 2-3. MODIFY 2-PORT SMARTCAL or AUTOCAL SETUP Dialog Box

The parameters are:

- the calibration type required
- the through type to be used
- whether to automatically or manually define the left/right test port assignments
- whether an adapter will be used

Most standard calibration types are available with the AutoCal units. Frequency response calibrations are the only ones omitted, since the SmartCal and AutoCal unit would provide no benefit in these cases since only a through or high reflect standard is needed for these calibrations. The SmartCal and AutoCal modules support:

- Full Two Port (also called Full 2-Port) calibration
- Full Port 1 (S_{11}) reflection only calibration
- Full Port 2 (S_{22}) reflection only calibration
- 1 Path 2 Port Forward (S_{11} , S_{21}) calibration
- 1 Path 2 Port Reverse (S_{22} , S_{12}) calibration

Adapter Removal

The DUT may require a different connector configuration than is on the current calibrator unit (e.g. F-F DUT and the auto cal is M-F). Adapter removal is one way of handling this situation by performing two auto calibrations with an adapter connected to the AutoCal. The instrument will guide the user through the required connections.

Through Options

For each calibration type above, there are two Thru calibration options:

- **Internal Thru**

The calibration module provides the internal through connections without the user having to move or reconnect the test cables. The benefit is speed of calibration balanced against potentially less accuracy and accommodates inexperienced operators such as in an assembly line testing station.

- **True Thru**

The calibration modules can also be configured to allow True Thru where the user is prompted when and how to connect the test cables to complete the calibration. The benefit is a higher accuracy calibrations balanced against a longer calibration time and more operator involvement.

SmartCal Test Port 1 / Port 2 Naming Assignments

The SmartCal module setup allows the user to specify the Port 1,2 identification of the test port cables as either:

- **SmartCal Module Orientation = Port A**

Where the module determines the Port A / Port B identification of the test port cables

- **SmartCal Module Orientation = Port B**

Where the module determines the Port A / Port B identification of the test port cables

AutoCal Test Port Left/Right Naming Assignments

The AutoCal module setup allows the user to specify the left/right identification of the test port cables as either:

- **Auto Sense Module Orientation = ON**

Where the module determines the left/right identification of the test port cables

- **Auto Sense Module Orientation = OFF**

Where the user defines either Left = Port 1 and Right = Port 2, or Left = Port 2 and Right = Port 1. This setting is useful where the VNA orientation is different for the operator.

2-5 MS46122A/B Typical Calibrator Connections

The typical F-F calibrator connections for MS46122A/B are shown below in [Figure 2-4](#). For MS46322A/B typical calibrator connections see [Figure 2-5](#).

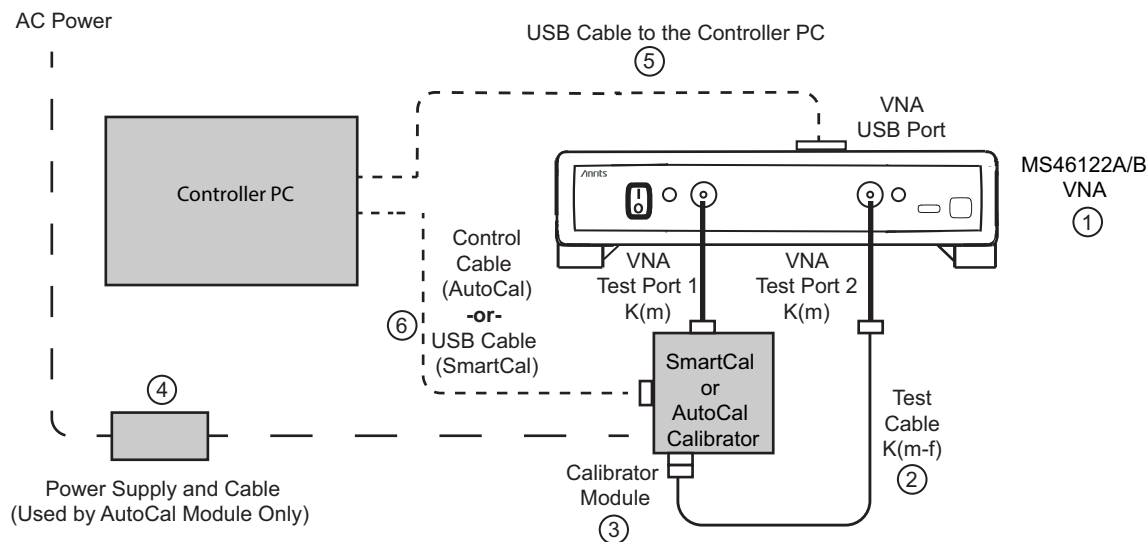

- | | |
|--|--|
| <ol style="list-style-type: none"> 1. MS46122A/B VNA with K connectors. 2. Test Cable K(m-f) 3. SmartCal or AutoCal Calibrator Module 4. AutoCal module only: Power supply and cable 5. USB cable between MS46122 and Controller PC | <ol style="list-style-type: none"> 6. AutoCal or SmartCal control cable to Controller PC
 AutoCal: Connects to the controller PC through a combination of a calibrator DB9 (m-m) cable with USB to serial adapter (2000-1808-R).
 SmartCal: Connects to the controller PC through a Micro-B to USB cable. |
|--|--|

Figure 2-4. MS46122A/B Calibration Module Connections for Internal Through

1. Prepare the MS46122A/B and power it up. This instrument example has two K(m) test ports.
2. Connect the Calibration Module directly to VNA Test Port 1 K(m).
3. Connect a USB cable from the Calibrator to the Controller PC.
4. Connect the 3-2000RS-1815 USB 2.0 A to Mini B cable from the MS46122A/B to the Controller PC.
5. The second Calibrator K(f) connector is connected to the K(m) end of the Test Cable. The test cable can be changed depending on measurement requirements. Cables on both VNA ports may be used, different types of cables may be used, or other configurations established. Then connect the K(f) end of the Test Cable to the VNA Test Port 2 K(m).

2-6 MS46322A/B Typical Calibrator Connections

The typical F-F calibrator connections for MS46322A/B are shown in [Figure 2-4](#). For MS46322A/B typical calibrator connections, see [Figure 2-5](#).

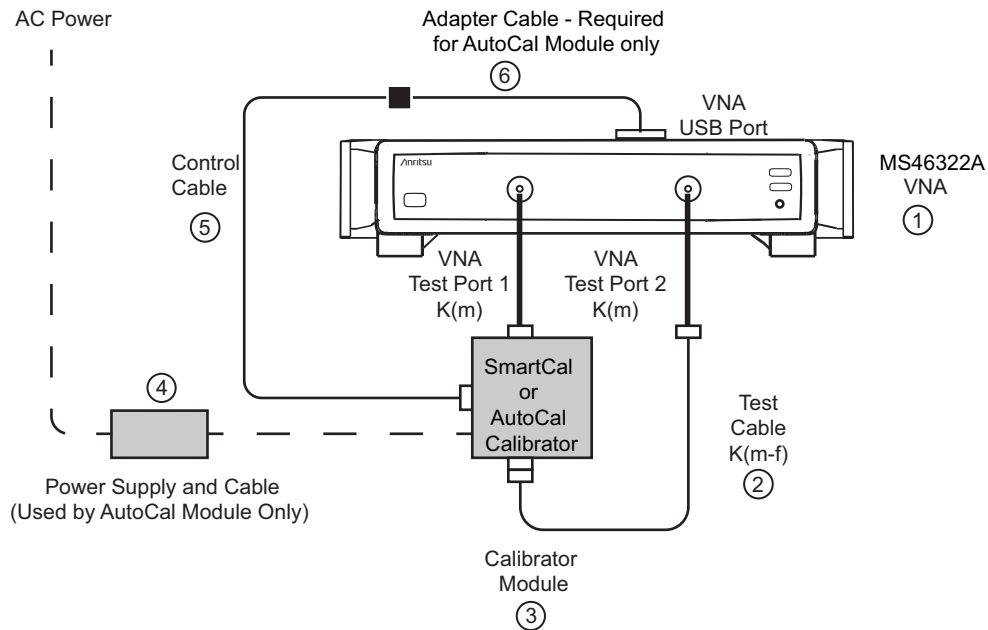

1. MS46322A/B VNA with K connectors.	5. AutoCal—Uses Calibrator DB9 (m-m) Control Cable connected between Calibrator Module and Adapter Cable (6) SmartCal—Uses Micro-B to USB cable into VNA USB Port
2. Test Cable K(m-f)	6. AutoCal—Uses USB to Serial Adapter (2000-1808-R)
3. SmartCal or AutoCal Calibrator Module	
4. AutoCal Power Supply Module with extension able to local AC Mains power (Used with AutoCal module).	

Figure 2-5. MS46322A/B Calibration Module Connections for Internal Through

6. Prepare the MS46322A/B and power it up. This instrument example has two K(m) test ports.
7. Connect the Calibration Module directly to VNA Test Port 1 K(m).
8. The AutoCal module is then connected to its AC Power Supply Module and it to AC power. The SmartCal module is powered from the USB of the VNA.
9. Connect the Serial to USB Adapter between the DB-9 connector on the top of the Calibration Module and the Serial Adapter (2000-1809-R) on the MS46322A/B rear panel.
10. The second Calibrator K(f) connector is connected to the K(m) end of the Test Cable. The test cable can be changed depending on measurement requirements. Cables on both VNA ports may be used, different types of cables may be used, or other configurations established. Then connect the K(f) end of the Test Cable to the VNA Test Port 2 K(m).

Schematically, this setup is shown in [Figure 2-6](#).

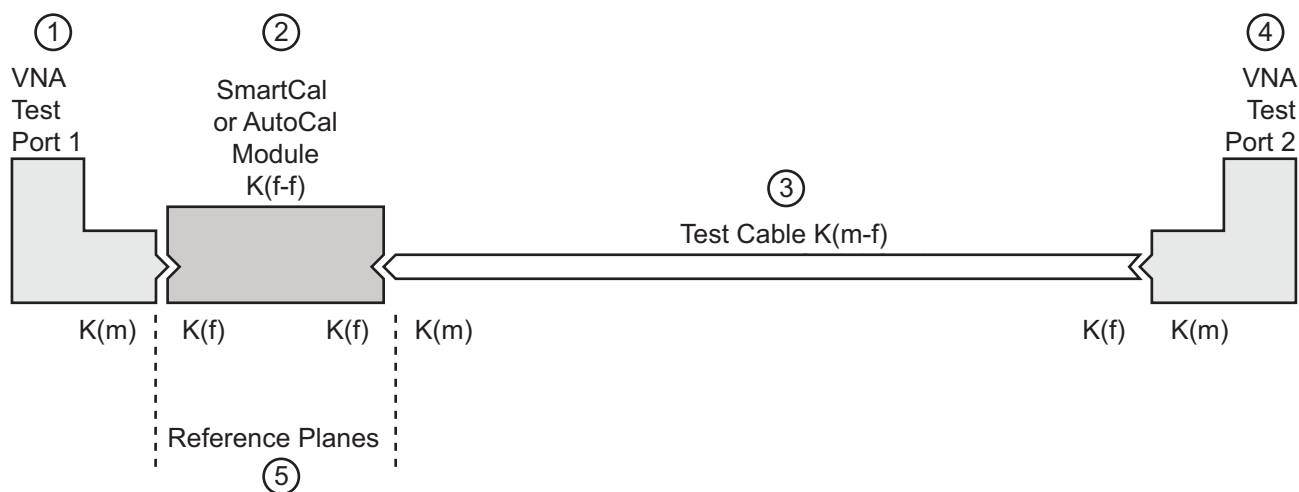

1. VNA Test Port 1 K(m)	4. VNA Test Port 2 K(m)
2. SmartCal or AutoCal Module	5. Resultant reference planes
3. K(m-f) Test Cable	

Figure 2-6. Schematic of the Calibrator Connections for Internal Thru

For optimal results, use the shortest cable lengths that do not require excessive bending when performing calibration or measurements. Results will be improved using the most practical phase- and amplitude-stable cables.

The power supply and control cables may be bundled for ease of routing or may be separated for convenience in some cases.

Using the Calibration Module

The calibration procedure can be broken up into several simple steps:

1. Power up the VNA and connect the control cable to the Calibration unit.
2. Install the characterization file if not already done.

Note

The SmartCal Characterization File is provided internally within the SmartCal memory and can be installed directly from that device.

The AutoCal Characterization File (ACD file) is provided on a USB memory device and can be installed directly from that device. These files can also be copied from the USB memory device to the MS46122A/B and MS46322A/B hard drive and installed from there. The preferred method is to copy all ACD files onto the hard drive, and then install the file for the specific AutoCal being used.

3. Setup the Calibrator and the VNA by connecting:

- Calibrator Module directly to one VNA Test Port
- A test cable between the Calibrator and VNA Test Port
 - For SmartCal, the USB cable connects between the Calibrator module and the VNA USB port.
 - For AutoCal, the Serial to USB cable will be placed in the path between the Calibrator module and the VNA USB port.

4. Connect the Calibration Module to its power supply
 - For SmartCal, power is supplied through the USB cable.
 - For AutoCal, connect the Calibration module to its power supply and AC power
 - For the SmartCal Module, the yellow Power LED illuminates immediately. When the module is recognized, the Operate LED will illuminate green.
 - For the AutoCal Module, the green Power LED illuminates immediately. When the module is at operating temperature, the Operate LED will illuminate blue.
5. Set up the VNA instrument for the desired calibration:
 - The required minimum settings are Frequency Start, Frequency Stop, and Number of Points.
 - If required, optional settings for Segmented Sweep, IF Bandwidth, and/or Averaging are applied.
6. Select the Calibrator parameters of interest and connect the test port cables to the Calibrator unit. Make the required selections for Cal Type, Thru Select, Adapter Removal, and Auto Sense Module.
7. Perform the calibration by clicking Begin Cal to start the auto calibration.
8. A status dialog box with a progress bar appears after an Calibration sequence has started. The status messages define how far the program has progressed and if any user actions are required.
9. At any time, the Calibration sequence can be canceled by clicking the dialog box Abort button.
10. If any manual steps are requested such as specifying a true-through, a dialog box will prompt for the action.
11. When the calibration is complete, a status message appears with a statement about assurance passing or failing. On the Calibration menu, the Cal Status field button shows ON.

Each procedure is described in greater detail in the following sections.

2-7 Copying the Calibrator Characterization File

The AutoCal Characterization File (.acd file) is provided on a USB memory device provided with the AutoCal Module.

Procedure

1. Inspect the Calibrator kit and make a note of its serial number. Typical Calibrator Kit serial numbers are six-digit integers such as “123456.”
2. Insert the AutoCal Characterization Memory Device (USB memory device) into one of the ShockLine VNA USB Ports.
3. Navigate to the CAL KIT menu:
 - MAIN | Calibration | Cal Kit Options | CAL KIT

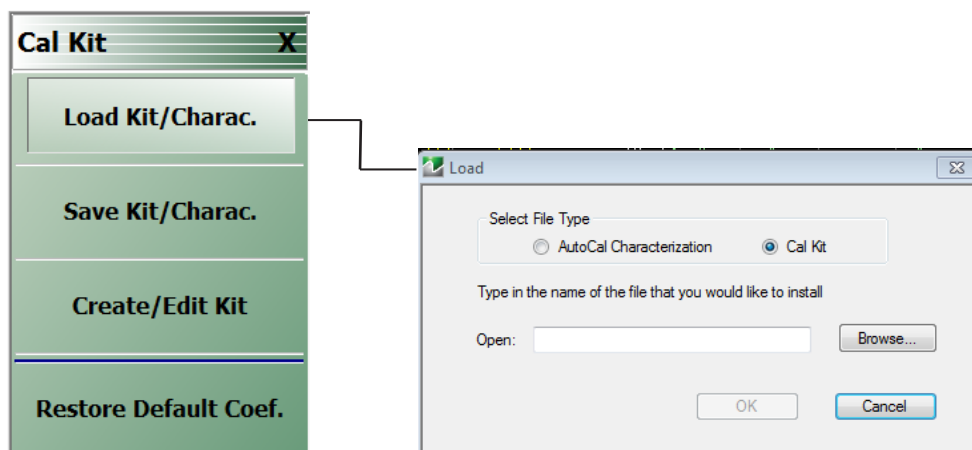

Figure 2-7. CAL KIT Menu – INSTALL CHARACTERIZATION FILE Dialog Box

4. On the CAL KIT menu, select Load Kit/Charac. The LOAD (AutoCal Characterization/CalKit) dialog box appears.
5. Select the AutoCal Characterization radio button and then click Browse. The Open (AutoCal ACD File) dialog box appears.
6. Navigate to the USB port location holding the USB memory device and select the file “v123456 .ACD,” where “123456” is the serial number of the Calibration kit.
7. Click the dialog box Open button. The Open dialog box closes; the LOAD dialog box re-appears.
8. Click OK in the LOAD dialog box. Another dialog box appears (this one showing the Calibration controller serial number, which is not the module serial number). Click Install in this box close it.
9. On the CAL KIT menu, select Save Kit/Charac. The Save (AutoCal Characterization) dialog box appears. Click OK.
10. Navigate to the required storage directory for the characterization file. The recommended directory destination on the MS46122A/B or MS46322A/B is C:\AnritsuVNA\AutoCal
11. Click Save. The Save dialog box closes, the CAL KIT menu reappears.
12. Repeat the steps above to copy each new Calibration Characterization File to the MS46122A/B or MS46322A/B.

2-8 Loading a Previously Stored AutoCal Characterization

This procedure applies to the AutoCal Module only. Use this procedure if the Calibration Characterization File has already been copied onto the ShockLine VNA hard drive.

Procedure

1. Navigate to CAL KIT menu.
 - MAIN | Calibration | CALIBRATION | CalKit Options | CAL KIT
2. On the CAL KIT menu, select Load Kit/Charac.
3. Select the AutoCal Characterization radio button and then click Browse.
4. Navigate to the hard drive (or USB memory device) location of the Calibration Characterization file for the Calibration module in use. The recommended directory destination on the MS46122A/B or MS46322A/B is C:\AnritsuVNA\AutoCal
5. Select the Calibration Characterization file, such as “V123456.ACD,” where “123456” is the serial number of the Calibration kit. Click Open.
6. Click OK in the LOAD dialog box. Another dialog box appears (this one showing the Calibration Module controller serial number, which is not the module serial number). Click Install in this box close it.
 - The LOAD dialog box closes and the CAL KIT menu is again available.

2-9 Pre-Calibration Instrument Setup

Use this procedure to setup the minimum required instrument configuration parameters:

- Frequency Start
- Frequency Stop
- Number of Points

Any other required measurement parameters must be defined and applied before the Calibration procedure. This section provides a highlight of typical additional measurement parameters.

Segmented Sweep

If required, segmented sweep must be setup in advance if the calibration needs a custom frequency list. See [“Frequency-Based Segmented Sweep” on page 13-3](#).

IF Bandwidth (IFBW) and Averaging

IF Bandwidth and Averaging control the digital filtering and post-processing that determine the effective noise floor, the amount of trace noise, and, in some cases, the immunity to interfering signals. The trade-off for improved noise performance is slower sweep speed.

Example Procedure

This example procedure assumes the ShockLine VNA is equipped with the Option 040 (1 MHz to 43.5 GHz) Low Frequency Extension and that only Frequency Start, Frequency Stop, Number of Points, and CW Mode settings are required.

1. Determine the values for the minimum setup parameters:

- Frequency Start: 10 MHz
- Frequency Stop: 40 GHz
- Number of Points: 200
- CW Mode: OFF
- Segmented Sweep: Not required
- IFBW: Defaults to 1 kHz
- Averaging: Defaults to no averaging

2. Power up the MS46122A/B or MS46322A/B and allow it to stabilize its internal temperature.

3. Navigate to the FREQUENCY menu:
 - MAIN | Frequency | FREQUENCY

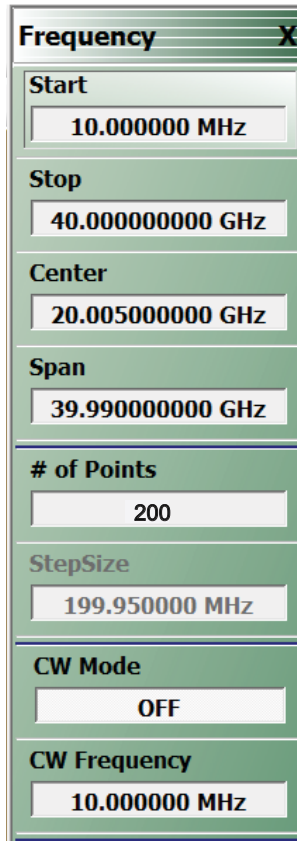

The screenshot shows a vertical menu titled "Frequency" with a close button (X) in the top right corner. The menu contains several input fields for calibration parameters:

- Start:** 10.000000 MHz
- Stop:** 40.00000000 GHz
- Center:** 20.005000000 GHz
- Span:** 39.990000000 GHz
- # of Points:** 200
- StepSize:** 199.950000 MHz
- CW Mode:** OFF
- CW Frequency:** 10.000000 MHz

1 – FREQUENCY Menu

Figure 2-8. FREQUENCY Menu - Setting Initial Calibration Parameters

4. On the FREQUENCY menu, click the Start frequency button
 - The frequency Start toolbar appears just below the icon toolbar
5. Enter the required start frequency number value.
 - For this example, set the start frequency value at 10.
6. Enter the required start frequency units.
 - For this example, set the units to megahertz by clicking MHz.
 - The Start frequency field button now shows 10 MHz
7. On the FREQUENCY menu, click the Stop frequency field button
 - The frequency Stop toolbar appears
8. On the Stop frequency toolbar, enter the required frequency number value and units.
 - For this example, set the stop value at 40 and click the GHz units button.
 - The Stop frequency button now shows 40.00000000 GHz
9. The Center and Span display buttons show calculated values based on settings made above
 - The Center frequency field button shows a value of 20.005000000 GHz
 - The Span frequency field button shows a value of 39.990000000 GHz

10. On the Frequency menu, click the # of Points (Number of Points) button
 - The # of Points toolbar appears
11. On the # of Points toolbar, enter the required number of points.
 - In this example, set the # of Points to 200 and then click Enter on the toolbar.
 - The # of Points field button shows 200
 - The Step Size display button automatically calculates the step size of 199.950000 MHz.
12. Click the CW Mode toggle button so it is set to OFF.
13. If optional parameters are required, do any of the following optional procedures described elsewhere in this manual:
 - [“Frequency-Based Segmented Sweep” on page 13-3](#)
 - [“IFBW” on page 11-27](#)
 - Averaging
 - Power and Attenuation
14. If no optional parameters are required, the Calibration is ready to proceed.
 - [“Calibration - Full Two Port - Internal Through” on page 2-17](#)

2-10 Calibration - Full Two Port - Internal Through

This procedure performs a calibration using a full two port calibration with an internal through, which is sufficiently accurate for most DUTs. For SmartCal, the Calibration Characterization file has already been loaded into the ShockLine software.

Note The examples below show calibration of the MS46122A/B and MS46322A/B. The procedure to calibrate the ME7868A is similar to the MS46122A/B procedure.

Note The navigational path to the Calibration setup applies to both the SmartCal and AutoCal calibration modules. Make the selection of the calibration module once you navigate through:
 MAIN | Calibration | CALIBRATION | AutoCal | AUTOCAL | 2-Port Cal | SMARTCAL SETUP
 Any selection in the SMARTCAL SETUP menu brings up the menu similar to the one in [Figure 2-9](#). This is where you choose the SmartCal or AutoCal module for your application.

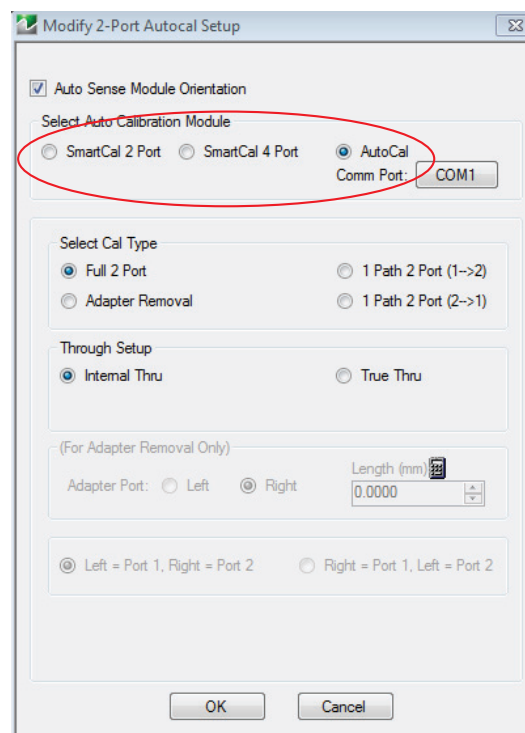

Figure 2-9. Select SmartCal or AutoCal

Required Equipment

- MS46122A/B or MS46322A/B VNA with K(m) test port connectors.
- Calibrator Module with K(f) connectors and required power and control cables. The Calibration Characterization File has been loaded onto the ShockLine VNA.
- Test port cable, K(f) to K(m)

Procedure

1. Power up the MS46122A/B or MS46322A/B VNA.

2. Set the required Frequency Start, Frequency Stop, and Number of Points parameters.
 - See “Pre-Calibration Instrument Setup” on page 2-14.
3. If required, set up other parameters as required, such as Segmented Sweep, IFBW, Averaging, and Power and Attenuation.
4. Navigate to CAL KIT menu.
 - MAIN | Calibration | CALIBRATION | AutoCal | AUTOCAL | 2-Port Cal | SMARTCAL SETUP | Thru Type

Calibrator Module Connections

5. Connect the Calibrator K(f) connector directly to the VNA left side K(m) Test Port 1.
6. If calibrating a MS46322A/B, skip to step 10.
7. If using a MS46122A/B, refer to [Figure 2-10](#), “MS46122A/B Calibrator Cable Connections for Internal Through”.
8. If using a MS46122A/B:
 - Connect one USB cable from the Calibrator to the Controller PC.
 - Connect the 3-2000RS-1815 USB 2.0 A to Mini B cable from the MS46122A/B to the Controller PC.
9. Skip to step 13
10. If using a MS46322A/B, refer to [Figure 2-11](#), “MS46322A/B Calibrator Cable Connections for Internal Through”.
11. Connect the Serial to USB Adapter between the DB-9 connector on the top of the Calibration Module and the Serial Adapter (2000-1809-R) on the MS46122A/B rear panel.
12. Connect the coaxial power plug from the Power Supply Module (AutoCal Module only) to the AutoCal Module.
13. Once connected to power, the Calibration Module Power LED will illuminate. When the module has warmed up to operating temperature, the LED illuminates blue for the AutoCal Module and Green for the SmartCal Module.
14. Connect the test cable between the K(m) Test Port 2 and the remaining AutoCal K(f) port

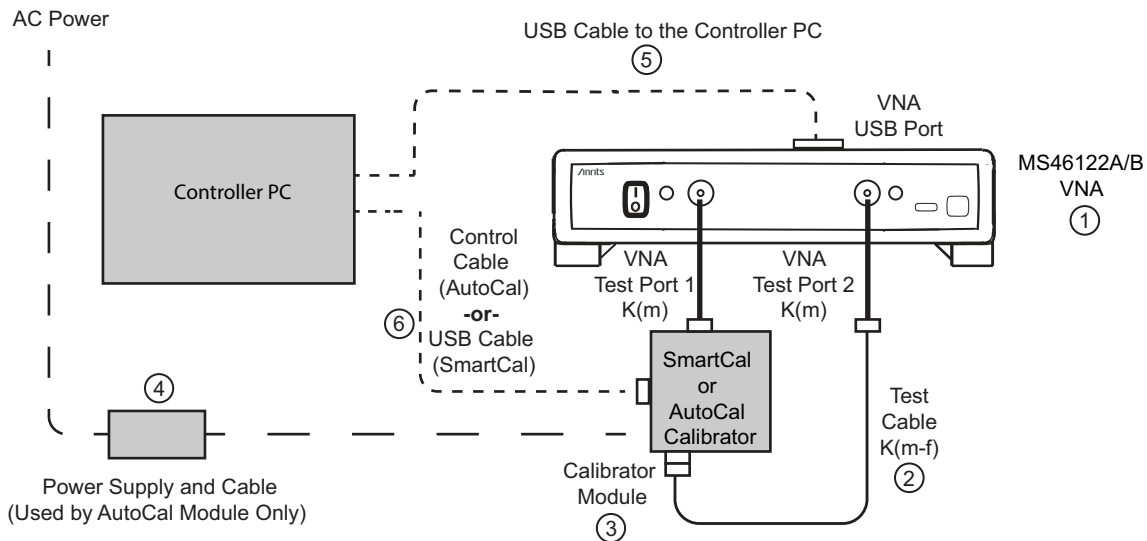
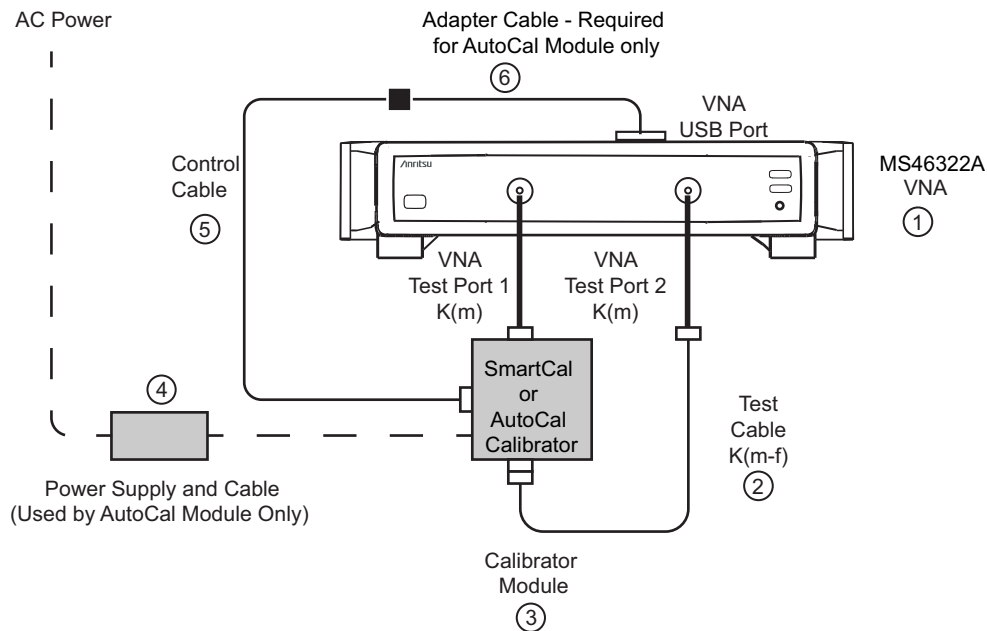

Figure 2-10. MS46122A/B Calibrator Cable Connections for Internal Through (1 of 2)

- | | |
|--|---|
| 1. MS46122A/B VNA with K connectors. | 4. AutoCal Power Supply Module connected to AC Power (Used with AutoCal module only) |
| 2. Test Cable K(m-f) | 5. USB control cable from MS46122B to controller PC |
| 3. SmartCal or AutoCal Calibrator Module | 6. DB9 (m-m) Control Cable (AutoCal) and RS232 to USB Adapter cable (2000-1809-R) -or- USB Cable (SmartCal) |

Figure 2-10. MS46122A/B Calibrator Cable Connections for Internal Through (2 of 2)

..



- | | |
|--|--|
| 1. MS46322A/B VNA with K connectors. | 5. AutoCal—Uses Calibrator DB9 (m-m) Control Cable connected between Calibrator Module and Adapter Cable (6)
SmartCal—Uses Micro-B to USB cable into VNA USB Port |
| 2. Test Cable K(m-f) | 6. AutoCal—Uses USB to Serial Adapter (2000-1808-R) |
| 3. SmartCal or AutoCal Calibrator Module | |
| 4. AutoCal Power Supply Module with extension able to local AC Mains power (Used with AutoCal module). | |

Figure 2-11. MS46322A/B Calibrator Cable Connections for Internal Through

15. Navigate to the AUTOCAL SETUP (2-Port) menu:

- MAIN | Calibration | CALIBRATION | Calibrate | CALIBRATE | AutoCal | AUTOCAL | 2-Port Cal | AUTOCAL SETUP (2-Port)

16. On the AUTOCAL SETUP (2-Port) menu, if the Port Selection, Cal Type, Thru Type, and Module Orientation display buttons do not show the correct values, click the Modify Cal Setup button.

- The MODIFY AUTOCAL SETUP dialog box appears. The exact name depends on the VNA mode and the user selections for the number of ports. The dialog box can be named:
 - MODIFY 1-PORT AUTOCAL SETUP dialog box
 - MODIFY 2-PORT AUTOCAL SETUP dialog box

- MODIFY 4-PORT AUTOCAL SETUP dialog box

17. In this example, the required settings are for a Full 2 Port Calibration, with Auto Sense Module Orientation ON, and Internal Through while running on a VNA in 2-Port Mode. The resultant configuration dialog box is named MODIFY 2-PORT AUTOCAL SETUP.

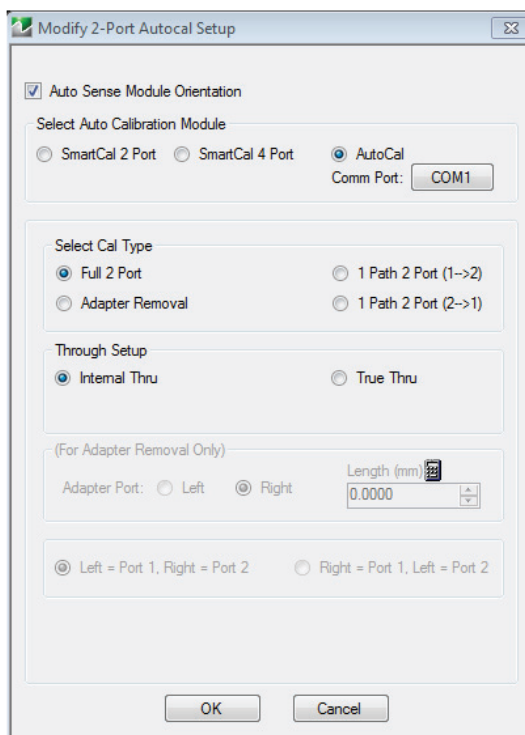

Figure 2-12. MODIFY 2-PORT AUTOCAL SETUP Settings

18. On the MODIFY 2-PORT AUTOCAL SETUP dialog box, select the settings:
 - a. Cal Type Select area: Select the Full Two Port radio button.
 - b. Thru Select area: Select the Internal Thru radio button.
 - c. Auto Sense Module Orientation check box selected: Allows the AutoCal module to determine left/right cable identification or the SmartCal Port A/B cable identification.
 - d. When the settings are complete, select OK to close the dialog box.
19. The AUTOCAL SETUP (2-Port) menu reappears with new values for Cal Type, Thru Type, and Module Orientation.
20. The window area at the bottom of the instrument display area appears with general instructions:
 - a. Ensure correct cable connections to Calibration module.
 - b. Ensure that the Power and Operate LEDs are both illuminated.
 - c. Ensure characterization file is loaded before starting Cal. To load characterization file, go to the LOAD (AutoCal Characterization) dialog box.
 - MAIN | Calibration | CALIBRATION | CalKit Options | CAL KIT | Load Kit/Charc. | LOAD (AutoCal Characterization)
 - d. Existing system setups such as averaging, power level, etc. will be applied during the cal

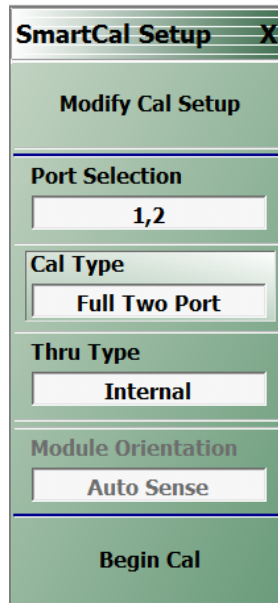

Figure 2-13. Configured SmartCal 2-Port Menu Setup

21. When ready, click the Begin Cal button.
22. If the Calibration module is connected incorrectly, SmartCal Module Not Detected warning message appears.
 - Connect the connections as required and click Retry..

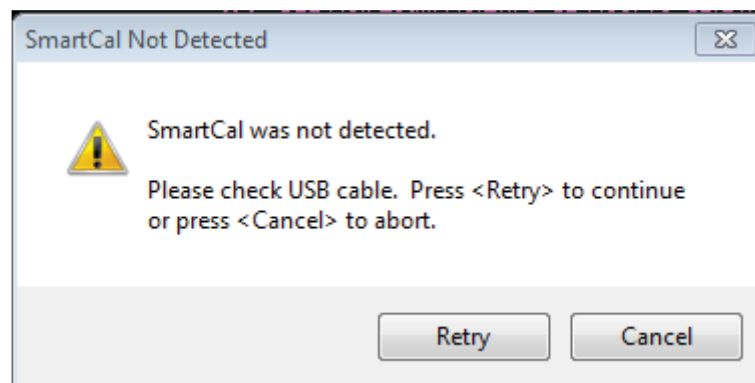

Figure 2-14. Not Detected Dialog

Note

A different dialog box may appear if the RF cables are connected incorrectly (with Autosense on) that states that Autosense was unable to determine the orientation of the module. If this dialog appears, and a large amount of loss is not present between the port and the Calibration module, check the connections. If a known large amount of loss is present (from the test fixtures or the use of very long cables), the orientation should be manually entered.

23. When the calibration is complete, the Status Message dialog box will close and the display will return to the CALIBRATION menu with the Cal Status button set to ON. The assurance dialog will remain up with the pass/fail message, and must be manually closed.

2-11 Calibration - Two Port Cal - True Through

This procedure performs a Calibrator procedure using a full two port calibration where a True Through (or external through) is required.

Note	The examples below show the MS46122A/B and MS46322A/B. The ME7868A calibration procedure is similar to the MS46122A/B.
-------------	--

Required Equipment

- MS46122A/B or MS46322A/B VNA with K(m) or N(f) test port connectors
- Calibrator Module with K or N (with (f) and (m) connectors) and required power and control cables. For AutoCal, the Calibration Characterization File has been loaded onto the MS46122A/B or MS46322A/B VNA.
- Test port cable K or N (f) to K or N (m)
- Test port cable K or N (f) to K or N (f), or a K or N (f) to K or N (f) adapter.

Procedure

1. Power up the MS46122A/B or MS46322A/B.
2. Set the required Frequency Start, Frequency Stop, and Number of Points parameters.
 - [“Pre-Calibration Instrument Setup” on page 2-14.](#)
3. If required, set up other parameters as required such as Segmented Sweep, IFBW, Averaging, and Power and Attenuation.
4. Make the necessary cable connections between the Calibrator Module and the MS46122A/B or MS46322A/B ([Figure 2-15 on page 2-23](#)):
 - a. Connect the Test Cable between Test Port 2 and the Calibrator port.
 - b. Connect the Test Cable between Test Port 1 and the Calibrator port.
 - c. If using AutoCal, connect the Serial to USB Adapter between the DB-9 connector on the Calibration Module and the USB Port on the MS46122A/B or MS46322A/B rear panel.
If using SmartCal, connect the USB cable between the Calibration Module and a USB port on the MS46122A/B or MS46322A/B front or rear panel.
 - d. Connect the coaxial power plug on the Power Supply Module (AutoCal Module only) to the AutoCal Module and the other end to AC power.
5. Once connected to power, the Power LED illuminates. When the module has warmed up to operating temperature, the LED illuminates blue for the AutoCal Module and Green for the SmartCal Module..

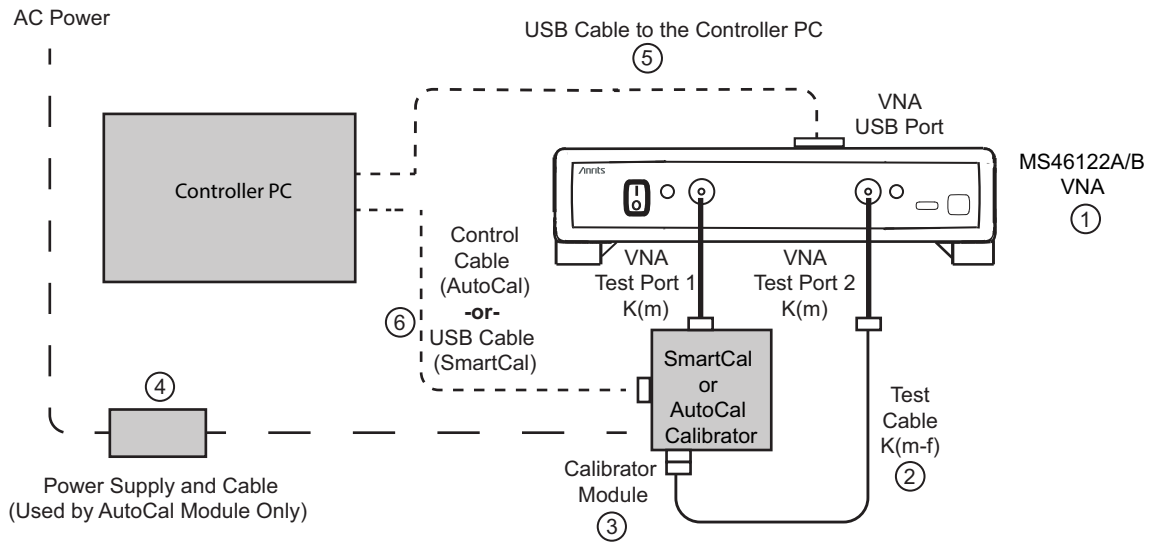

- | | |
|--|---|
| <ol style="list-style-type: none"> 1. MS46122A/B VNA with K connectors. 2. Test Cable K(m-f) 3. SmartCal or AutoCal Calibrator Module | <ol style="list-style-type: none"> 4. AutoCal Power Supply Module connected to AC Power (Used with AutoCal module only) 5. USB control cable from MS46122B to controller PC 6. DB9 (m-m) Control Cable (AutoCal) and RS232 to USB Adapter cable (2000-1809-R)-or- USB Cable (SmartCal) |
|--|---|

Figure 2-15. MS46122A/B Calibrator Cable Connections for True Through

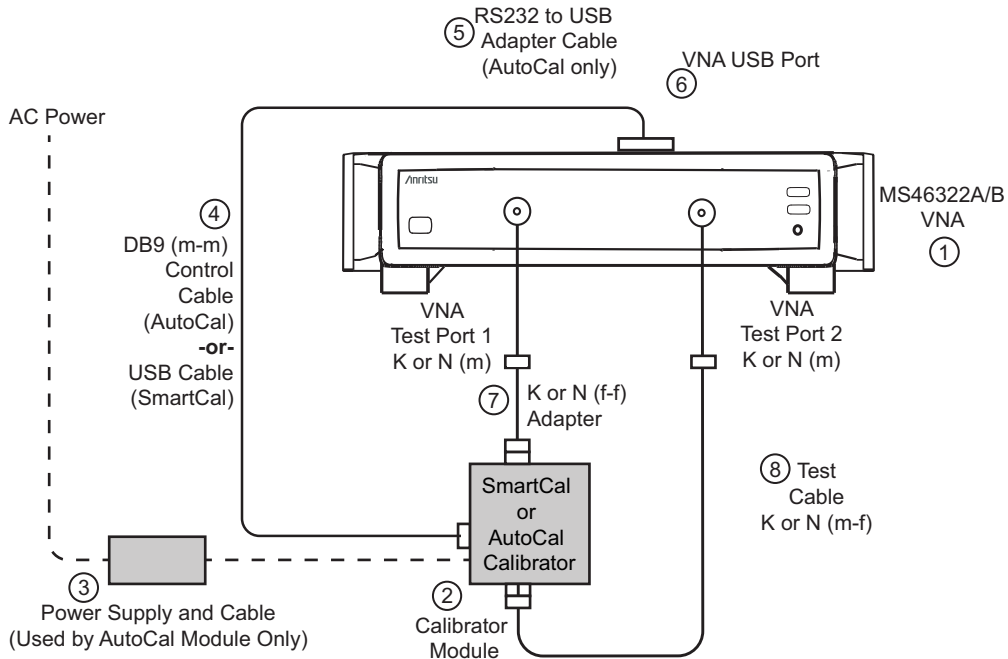

Figure 2-16. MS46322A/B Calibrator Cable Connections for True Through

- | | |
|--|--|
| 1. MS46522B VNA with K or N (m) Test Port Connectors | 4. DB9 (m-m) Control Cable (AutoCal) -or- USB Cable (SmartCal) |
| 2. SmartCal (K or N) or AutoCal (K) Calibrator (AutoCal does not support N connectors) | 5. RS232 to USB Adapter Cable (2000-1809-R) |
| 3. AutoCal Power Supply Module connected to AC Power (Used with AutoCal module only) | 6. VNA USB Port |
| | 7. K or N (f-f) Adapter connected to VNA Test Port 1 |
| | 8. K or N (m-f) Test Cable connected to VNA Test Port 2 |

Figure 2-16. MS46322A/B Calibrator Cable Connections for True Through

Schematically, the connections shown in Figure 2-15 and Figure 2-16 above are shown in Figure 2-17.

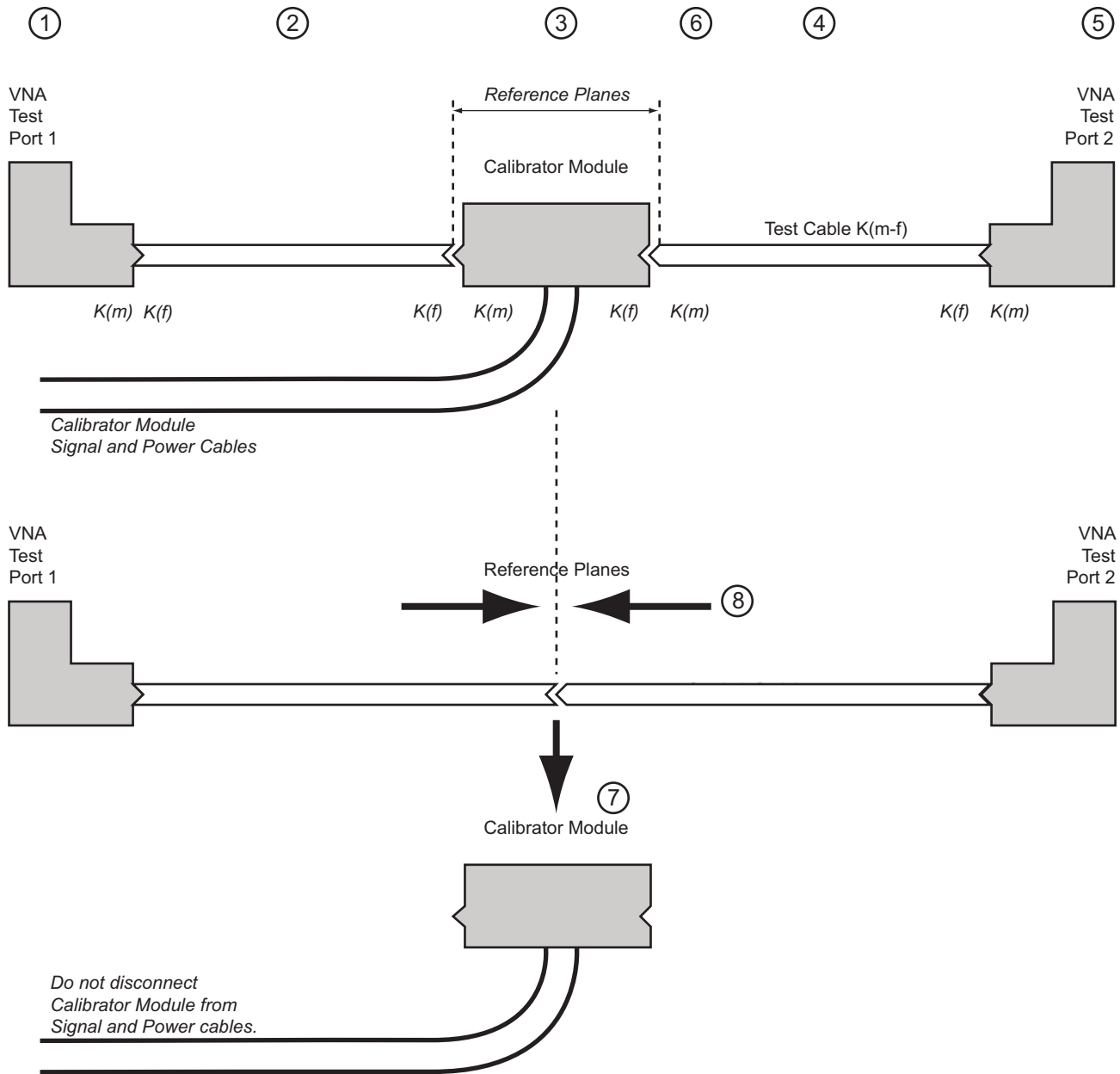

Figure 2-17. Calibration Module True-Through Connections (1 of 2)

Part 1 – Calibration True Thru Procedure

1. VNA Test Port 1 K(m)
2. K(f-f) Test Cable
3. Calibrator Module
4. K(m-f) Test Cable
5. VNA Test Port 2 K(m)
6. Resultant reference planes during first Calibration procedure.

Part 2 – Calibration True Thru Procedure

7. After initial calibrations, user is directed to remove Calibration module and connect test cables.
8. Connect the two Test Cables together to complete the through calibration.

Figure 2-17. Calibration Module True-Through Connections (2 of 2)

6. Navigate to the AUTOCAL SETUP menu:

- MAIN | Calibration | CALIBRATION | Calibrate | CALIBRATE | AutoCal | AUTOCAL | 2-Port Cal | AUTOCAL SETUP

7. On the AUTOCAL SETUP menu, if the Cal Type, Thru Type, and Module Orientation display buttons do not show the correct values, select the Modify Cal Setup button.

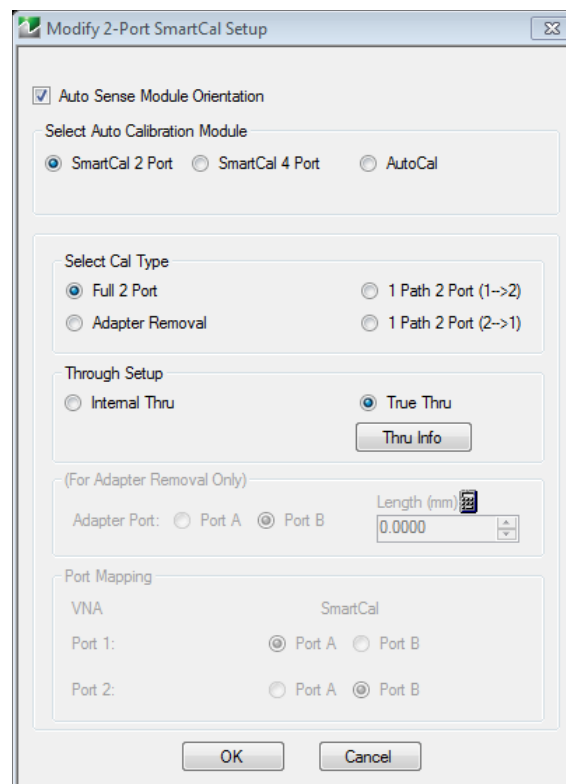
**Figure 2-18.** True Thru Selected

- a. The MODIFY 2-PORT AUTOCAL SETUP dialog box appears.
- b. Change the settings as required.
- c. In the Cal Type Select area, select the Full Two Port radio button.
- d. In the Thru Setup area, select Thru Info, the THRU INFO dialog box appears.
- e. Enter information about the through line. Enter 0 length and 0 dB/mm loss (and a reference frequency of 0, which forces it to use that loss at all frequencies) and 50 ohm impedance. Select OK to close the dialog box.

8. Select the Auto Sense Module Orientation check box
9. Click OK to close the dialog box.

Note All existing system setups such as IF Bandwidth, Averaging, and Power Level will be applied during the calibration procedure.

10. When ready, click the Begin Cal button.
11. A status dialog box with a progress bar appears after an Calibration sequence has started. The status messages define how far the program has progressed and if any user actions are required.
12. At any time, the Calibration sequence can be canceled by clicking the dialog box Abort button.

Connect the True Through

1. A dialog box will appear when the true through is to be connected.
 - If using a MS46122A/B ShockLine VNA, refer to [Figure 2-20](#) when connecting the True-Through
 - If using a MS46322A/B ShockLine VNA, refer to [Figure 2-21](#) when connecting the True-Through
2. Connect the Test Port 1 test cable to the Test Port 2 test cable.

If the Calibration module is connected incorrectly, the AUTOCAL NOT DETECTED warning message appears, [Figure 2-19](#). Correct connections as required and click the Retry button..

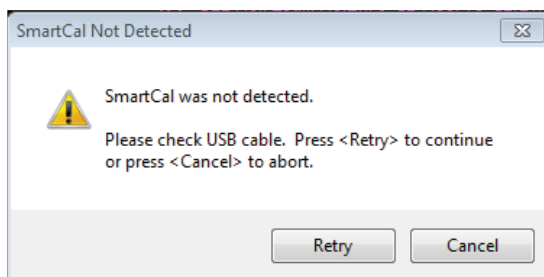
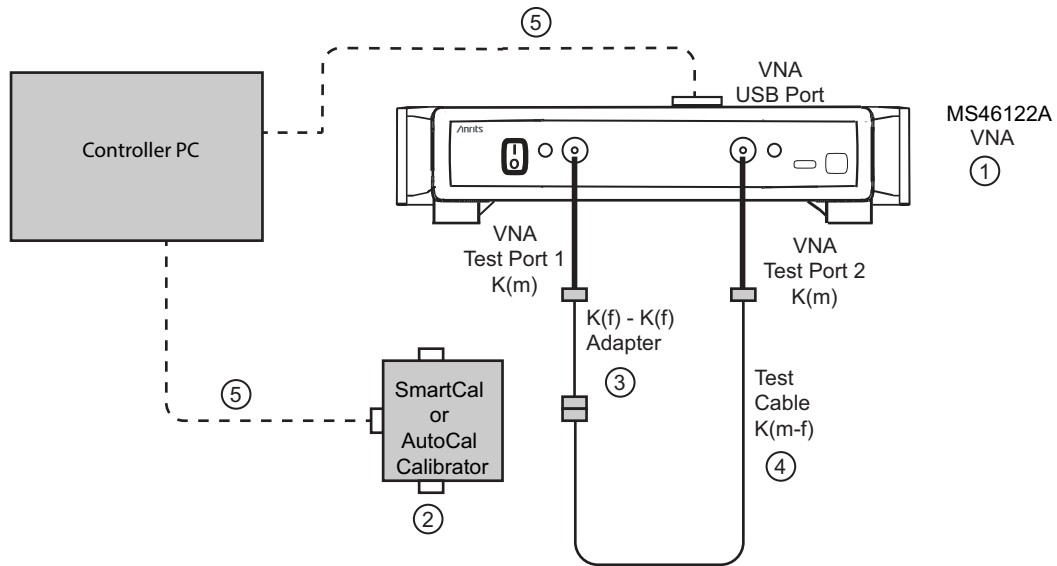
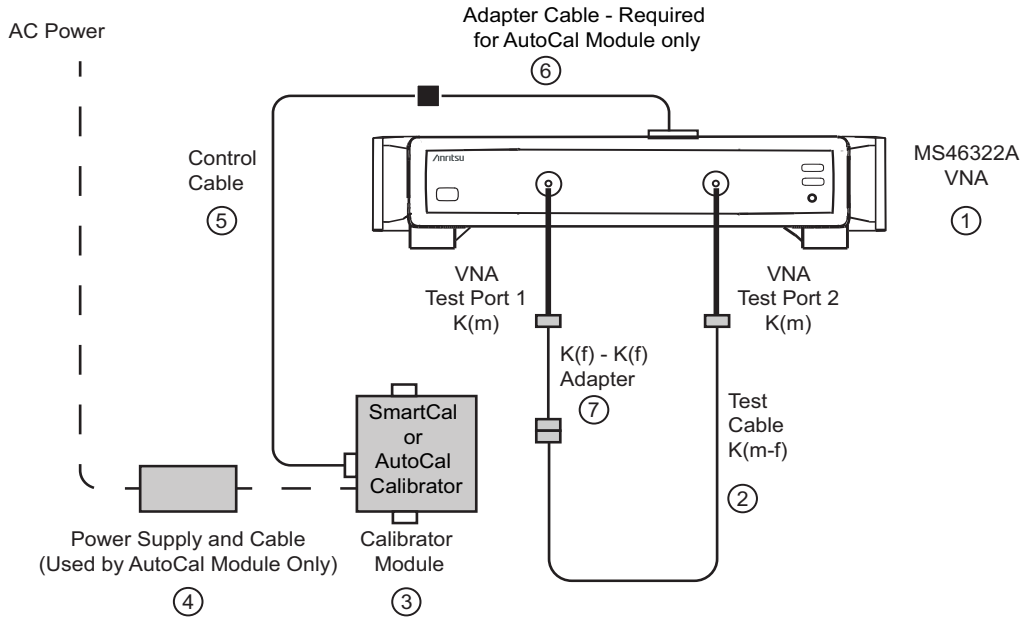

Figure 2-19. SmartCal Not Detected



- | | |
|---|---|
| 1. MS46122A/B with K Test Port Connectors | 4. K(m-f) Test Cable connected to K(f-f) adapter and Test Port 2 K(m) |
| 2. SmartCal or AutoCal Calibrator Module | 5. USB cable for SmartCal or serial cable and USB to serial adapter for AutoCal |
| 3. K(f) to K(f) Adapter connected to Test Port 1 K(m) | |

Figure 2-20. MS46122A/B True-Through Connections - Module Removed



- | | |
|--|--|
| <ol style="list-style-type: none"> 1. MS46322A/B with K Test Port Connectors 2. SmartCal or AutoCal Calibrator Module 3. AutoCal Module Power Supply connected to AC Power. AutoCal module and connect test cables. At all times during the calibration procedure, the AutoCal module must be connected to the VNA and to AC power. | <ol style="list-style-type: none"> 4. Calibration Module DB9 (m-m) Signal Cable connected to VNA Rear Panel Serial 10101 Port 5. K(f) to K(f) Adapter connected to Test Port 1 K(m) 6. K(m-f) Test Cable connected to K(f-f) adapter and Test Port 2 K(m) |
|--|--|

Figure 2-21. MS46322A/B True-Through Connections - Module Removed

3. After connecting the through, select Continue.
4. When the auto calibration is complete, a status message appears with a statement about assurance passing or failing. On the CALIBRATION menu, the Cal Status field button shows ON.
5. Closing the dialog box returns to the CALIBRATION menu.

2-12 Calibration Module Characterization

Characterization

Typically, characterization is performed by Anritsu since the process can be very carefully controlled for maximum accuracy. In certain cases, the customer may wish to perform the characterization themselves but it is important to note that all specifications for the calibration are void and the customer takes responsibility for performing a characterization of adequate quality. With that caveat, the process for performing a characterization is as follows:

1. Setup the instrument for the frequency range, point count, power level, and IFBW desired. It is particularly important to use as many points as reasonable in order to reduce interpolation needs.
2. Perform as high a quality manual calibration as possible at the reference planes that will be connected to the Calibration module.
3. Connect the Calibration module to the reference planes, apply power, and connect the control cable to both the Calibration module and to the ShockLine VNA. Allow the Calibration module to reach operating temperature so the blue Operate LED illuminates.
4. Select the SmartCal Characterization menu (Figure 2-22) to start the SmartCal characterization. For the AutoCal characterization, the user can choose to load or save the AutoCal characterization file. AutoCal recharacterization is not enabled on ShockLine VNAs (Figure 2-23). The VNA will automatically switch the unit through its various states and characterize them. Alternatively, the connected test port order may be specified and may be necessary if there is substantial loss in the test setup (note that this may indicate an accuracy hazard).
 - MAIN | System | SYSTEM | Utility | UTILITY | SmartCal Characterization | SMARTCAL
 - MAIN | System | SYSTEM | Utility | UTILITY | AutoCal Utility | AUTOCAL UTILITY
5. Save the characterization file as appropriate. Note that the characterization file will be tied by serial number to the particular Calibration module that was characterized.

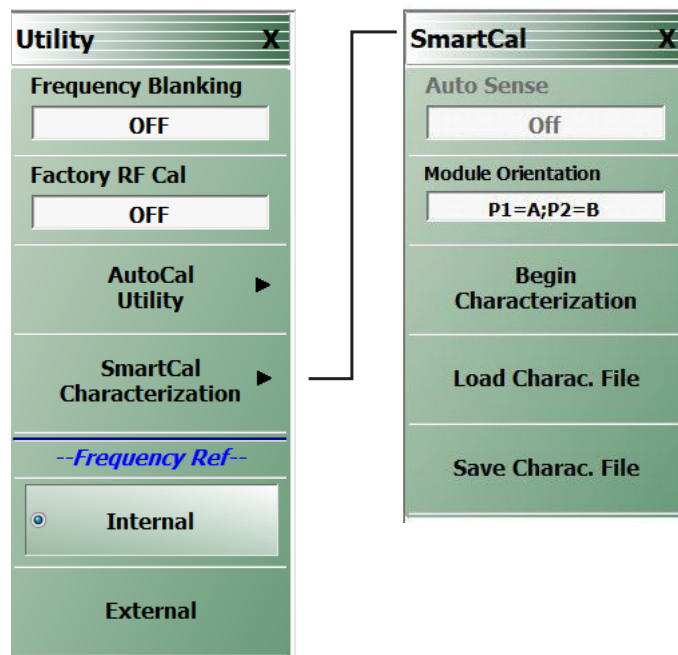

Figure 2-22. SMARTCAL (SMARTCAL CHARACTERIZATION) Menu

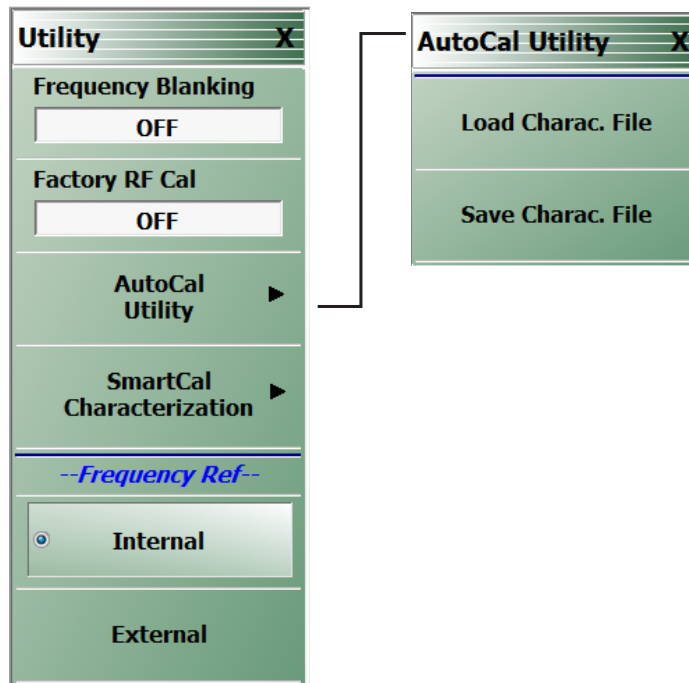

Figure 2-23. AUTOCAL UTILITY Menu

2-13 Adapter Removal — M-M or F-F Reference Plane

Adapter Removal Overview

Adapter removal for Calibration modules primarily refers to the case of connector gender incompatibility when it is not desired to use test port converters such as when the user has a M-F Calibration module and M-M reference planes are required. A separate menu item is provided for Calibration adapter removal to speed up the process, since fewer manual steps are needed. In this calibration sequence, one uses an adapter (that can mate the desired reference plane connectors) as part of the calibration.

Two possible scenarios are covered; both use a pair of calibration sequences to remove the effects of the adapter. In both of the cases below, it is assumed all connectors are from the same family. If not (e.g., one is using a special inter-series Calibration unit), then this Calibration-specific adapter removal technique may not be applied; see the standard adapter removal section.

This procedure performs an Calibration procedure when an adapter is required to accommodate either the Calibration unit or the DUT connector genders and a M-M reference plane is required.

Required Equipment

- **VNA**
MS46122A/B or MS46322A/B VNA with K Test Port Connectors
- **Calibration Module**
Precision Calibration Module, with K(f-m) connectors. Includes the necessary Power Supply Module with cords to AutoCal Module and to AC power or the SmartCal Calibrator module that only requires the USB cable connection to the PC Controller.
- **Test Cable**
A test port cable with K(m-f) connectors
- **K(f-f) Adapter**
A Matched K Adapter, 36583K with K(f-f) connectors.

Prerequisites

The following prerequisite procedures have already been accomplished:

- Calibration Characterization file previously loaded.
- MS46122A/B or MS46322A/B is powered up.
- Required settings for Frequency Start, Frequency Stop, Number of Points, and CW Mode configured.
- Optional settings as required for Segmented Sweep, IF Bandwidth, Averaging, and Port Power configured.

Procedure

1. Make the necessary cable connections between the AutoCal Module, its Power Module, AC power, and the ShockLine VNA back panel.
 - When the blue Operate LED is illuminated, the module has warmed up and is ready for calibration operations.
2. Connect the K(f-f) Adapter to the Calibration Module K(m) connector.

- Consider the Adapter and Calibration module as an “assembly” for the duration the Calibration procedure.

Note Once assembled, do not break the connection between the adapter and the Calibration module, do not disconnect the assembly from the USB port, and do not disconnect the assembly from AC power. If the connection between the adapter is broken before the Calibration procedure is completed, the entire calibration is invalidated and must be repeated.

3. Connect the remaining 36583K(f) connector to the MS46122A/B or MS46322A/B Test Port 1 K(m) connector.
4. Connect the Test Cable K(f) connector to the MS46122A/B or MS46322A/B Test Port 2 K(m) connector.
5. Connect the Test Cable K(m) connector to the Calibration Module K(f) connector.

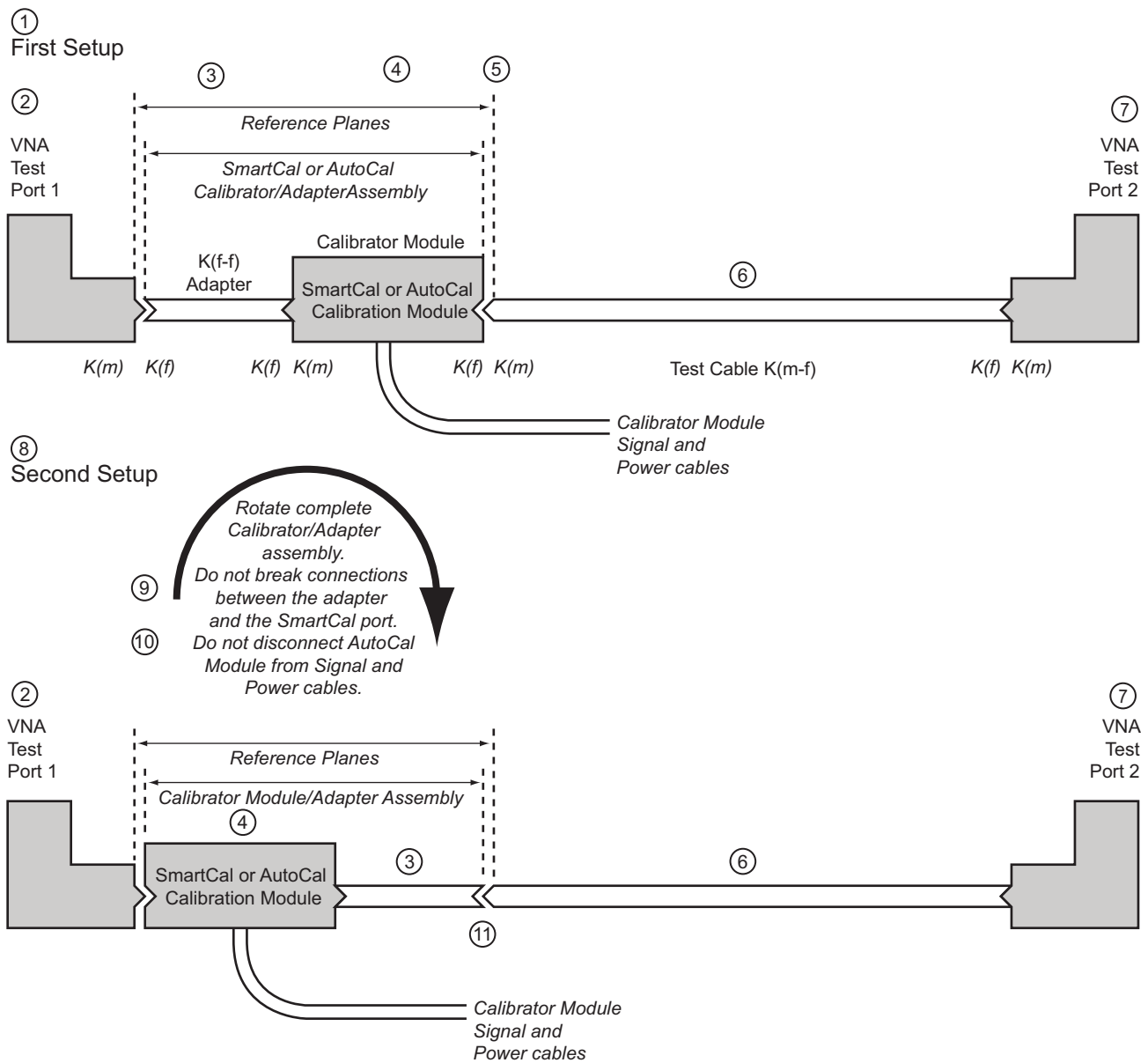

Figure 2-24. Calibrator, Adapter Removal, Internal Thru (1 of 2)

Part 1 – Calibration Adapter Removal Procedure

1. First setup for the Adapter Removal procedure.
2. VNA Test Port 1
3. K(f-f) Adapter
4. Calibration Module– For the duration of the calibration, the K(f-f) Adapter and the Calibration Module must be connected as an assembly. Do not disassemble or disconnect from its Power and Signal cables.
5. Resultant calibration reference planes.
6. K(m-f) Test Cable
7. VNA Test Port 2

Part 2 – Calibration Module Adapter Removal Procedure

8. Second setup for the Adapter Removal procedure.
9. After the first calibration, rotate the complete assembly so that the calibrator K(f) connector is connected to VNA Test Port 1. Do not disconnect the Adapter from the Calibration module.
10. Do not disconnect the Calibration Module from its Power or Signal cables.
11. Connect the K(f-f) adapter to the Test Cable K(m-f). The reference planes remain in place. The user is guided through the remaining steps of the procedure.
- 12.

Figure 2-24. Calibrator, Adapter Removal, Internal Thru (2 of 2)

6. Navigate to the AUTOCAL SETUP menu.

- MAIN | Calibration | CALIBRATION | Calibrate | CALIBRATE | AutoCal | AUTOCAL PORTS | 2-Port Cal | AUTOCAL SETUP

7. If the Cal Type, Thru Type, and Module Orientation display buttons do not show the correct values, select the Modify Cal Setup button.

- The MODIFY CALIBRATION SETUP dialog box appears.

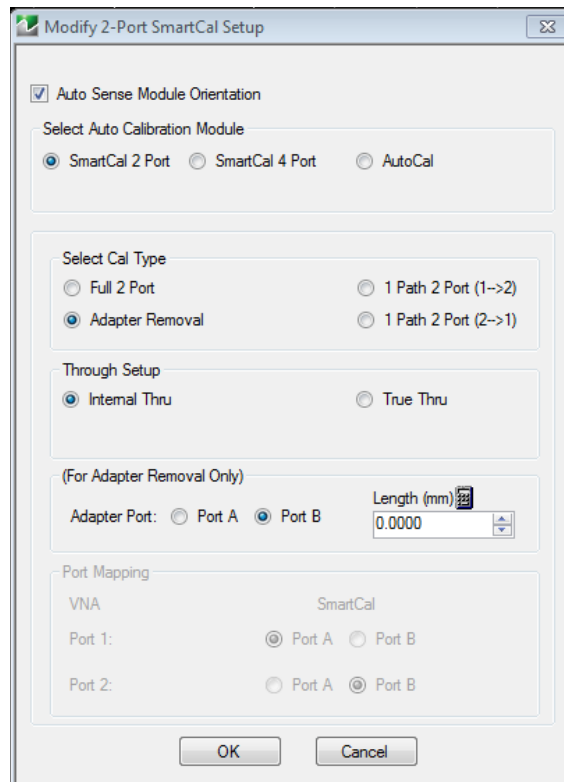
**Figure 2-25.** Adapter Removal Selected

8. Make the following changes to the MODIFY CALIBRATION SETUP dialog box settings:
 - a. Select the Auto Sense Module Orientation check box which allows the Calibration module determine the AutoCal Module left/right cable identification or SmartCal Module Port A/B cable identification.
 - b. In the Select Cal Type area, select the Adapter Removal radio button. The For Adapter Removal Only area becomes available.
 - c. In the Through Setup area, select the Internal Thru radio button and Adapter Removal.
 - d. In the For Adapter Removal Only area, enter the estimate of electrical length (in mm) and select which Calibration port the adapter is attached to.
 - e. Select OK to close the dialog box. The AUTOCAL SETUP menu reappears with new values for Cal Type, Thru Type, and Module Orientation.

Note	All existing system setups such as IF Bandwidth, Averaging, and Power Level will be applied during the calibration procedure.
-------------	---

9. When ready, click the Begin Cal button.
10. If the Calibration module is connected incorrectly, the Calibration Module Not Detected warning message appears. Correct connections as required and click Retry.
11. A status dialog box with a progress bar appears after an Calibration sequence has started. The status messages define has far the program has progressed and if any user actions are required.
12. At any time, the calibration sequence can be canceled by clicking the dialog box Abort button.
 - When the first calibration process is complete, the user is prompted to reverse the Adapter/Calibration assembly.

Note	Once assembled, do not break the connection between the adapter and the Calibration module. If the connection between the adapter is broken before the Calibration procedure is completed, the entire calibration is invalidated and must be repeated.
-------------	--

13. The instrument will prompt the user to reverse the module-adapter assembly.
14. As shown above in [Figure 2-24, “Calibrator, Adapter Removal, Internal Thru”](#) on page 2-32 above, disconnect the Adapter from Test Port 1 and the Calibration Module from the Test Cable on Test Port 2.
15. Reverse the Adapter/Calibration Module assembly so that the Adapter end is pointing towards Test Port 2.
16. On the Calibration module, connect the free K(f) connector to Test Port 1 K(m).
17. On the Adapter, connect the free Adapter K(f) connector to the Test Cable connected to Test Port 2.
18. When the calibration is complete, a status message appears with a statement about assurance passing or failing. Closing the dialog will return to the regular menu system. On the CALIBRATION menu, the Cal Status field button shows ON.

Chapter 3 — SOLT/SOLR Calibration

3-1 SOLT/SOLR Introduction

This chapter describes calibration procedures using the SOLT/SOLR (SOLT/R) calibration algorithms. One of the more common calibration algorithms is based on Short-Open-Load-Thru. This is a defined-standards calibration, meaning the behavior of all of the components is specified in advance via data or models.

Since the behaviors of all standards are known, by measuring them with the VNA we can define all of the error terms. The load behavior largely sets the directivity terms, the short and open together largely determine source match and reflection tracking and the thru largely determines transmission tracking and load match.

Note SOLR and LRL/LRM calibration methods are available with the “B” models and ME7868A only.
--

3-2 Definitions

Shorts

Shorts can be defined by a model consisting of a transmission line length and a frequency-dependent inductance.

Opens

Opens can be defined by a model consisting of a transmission line length and a frequency-dependent capacitance.

Loads

Loads can be defined by a model consisting of a transmission line length, a shunt capacitance, a resistance and a series inductance.

Note that a sliding load can be used in lieu of a fixed load. The sliding load is based on a sliding termination embedded in an airline and the transmission line properties of that airline are used to deduce a more nearly perfect synthetic load. Because of the transmission line dependence, a fixed load is needed at frequencies below 2 GHz.

Thru

Modeled as a transmission line length with some frequency dependent loss. A root-f frequency dependence of that loss is assumed. A .s2p-defined thru is also possible where loss and mismatch are used. Interpolation and extrapolation of the .s2p data will be used to complete the calibration. A 'characterize thru' option is also available to help generate such an .s2p file based on a network extraction method (Type B, see [Chapter 8](#) of this guide for more information).

Reciprocal

The thru can sometimes be replaced by a unknown but reciprocal network (like an adapter or a fixture) when an actual thru connection is not practical. The accuracy will be somewhat less than if an actual thru could have been used but will be better than assuming a poor thru is a good one.

3-3 Setup

The coaxial setup dialog for SOLT/R full 2-Port calibration is shown in below in [Figure 3-1](#).

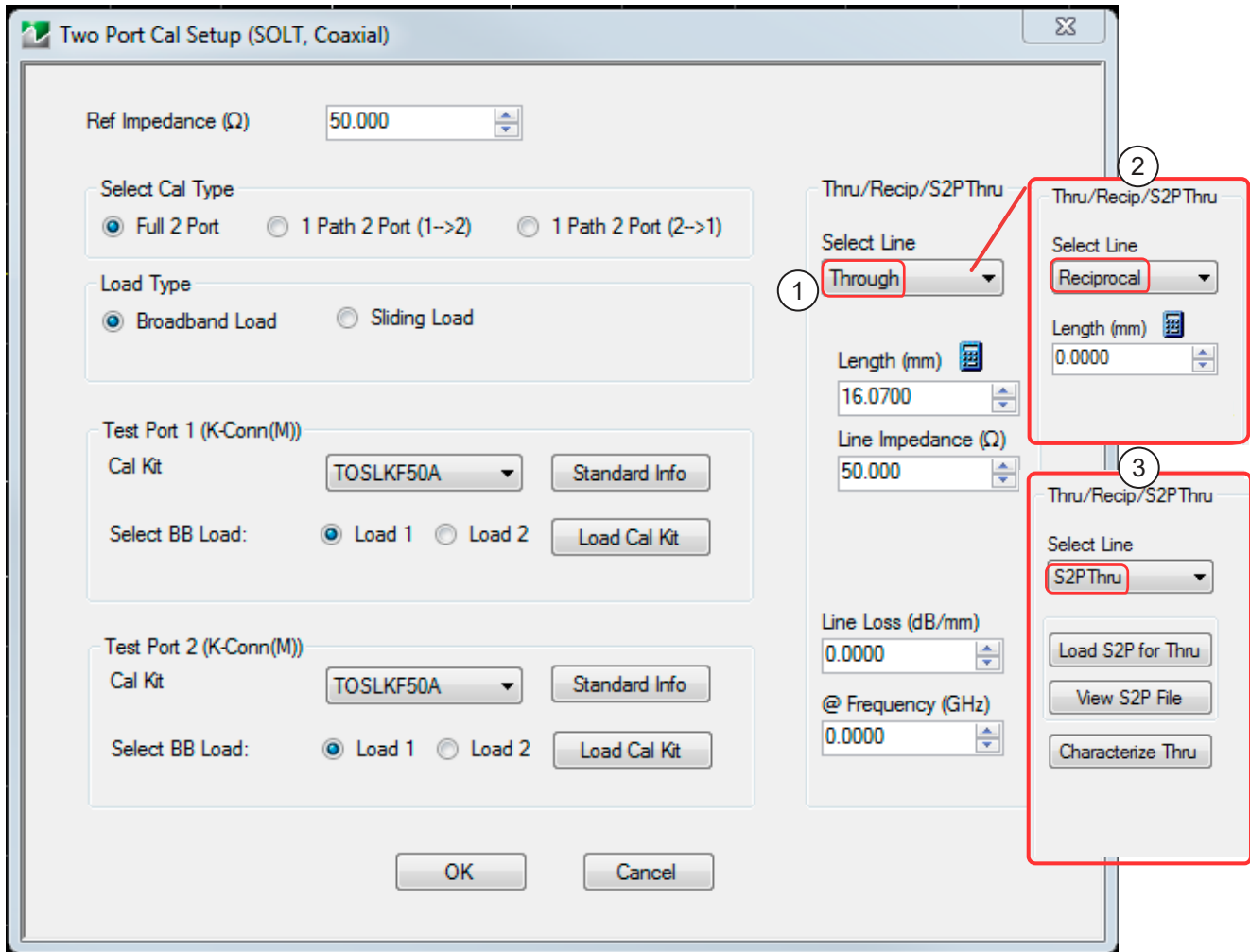

1. Through selected allows user entries for length, line impedance, line loss and frequency.
2. Reciprocal selected allows user entry for length.
3. S2P Thru selected provides buttons for loading, viewing, and characterization (to generate S2P files).

Figure 3-1. TWO PORT CAL SETUP (SSLT, COAXIAL) Dialog Box

The setup dialog above is for coaxial and non-dispersive line types. In the dialog, the connector types for both ports are selected, as well as the through details and the type of load to be used. For one port calibrations, only one of the port definitions (unless reflection-only calibrations are being performed for both ports 1 and 2) will be present. For a 1 path-2 port cal, one of the Test Port definition sections will not be shown.

The setup dialog above is for coaxial and non-dispersive line types. For waveguide and microstrip, a few things change:

- Fewer cal kits are factory-defined and more are user-defined
- The media must be part of the definition (cutoff frequency and dielectric constant for waveguide; line width, substrate height, and substrate dielectric constant for microstrip)
- SOLT/SOLR is not recommended for waveguide due to the difficulty in modeling and open standards

1. A waveguide SOLT/R setup is shown in [Figure 3-2](#) and a setup for microstrip is shown in [Figure 3-3](#).

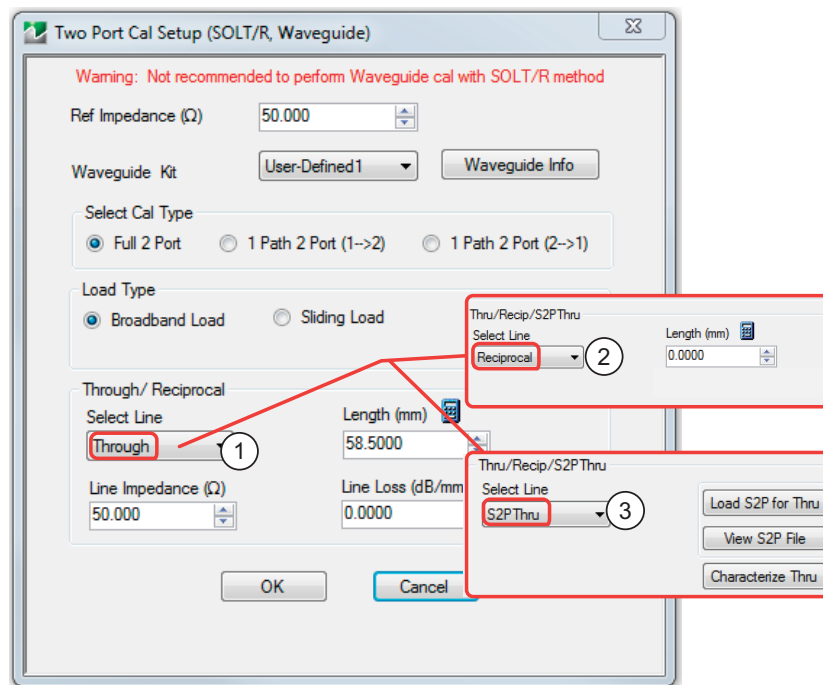

1. Through Line selected allows user entries for length, line impedance, line loss and frequency.
2. Reciprocal selected allows user entry for length.
3. S2P Thru selected provides buttons for loading, viewing, and characterization (to generate S2P files).

Figure 3-2. TWO PORT CAL SETUP (SOLT/R, WAVEGUIDE) Dialog Box

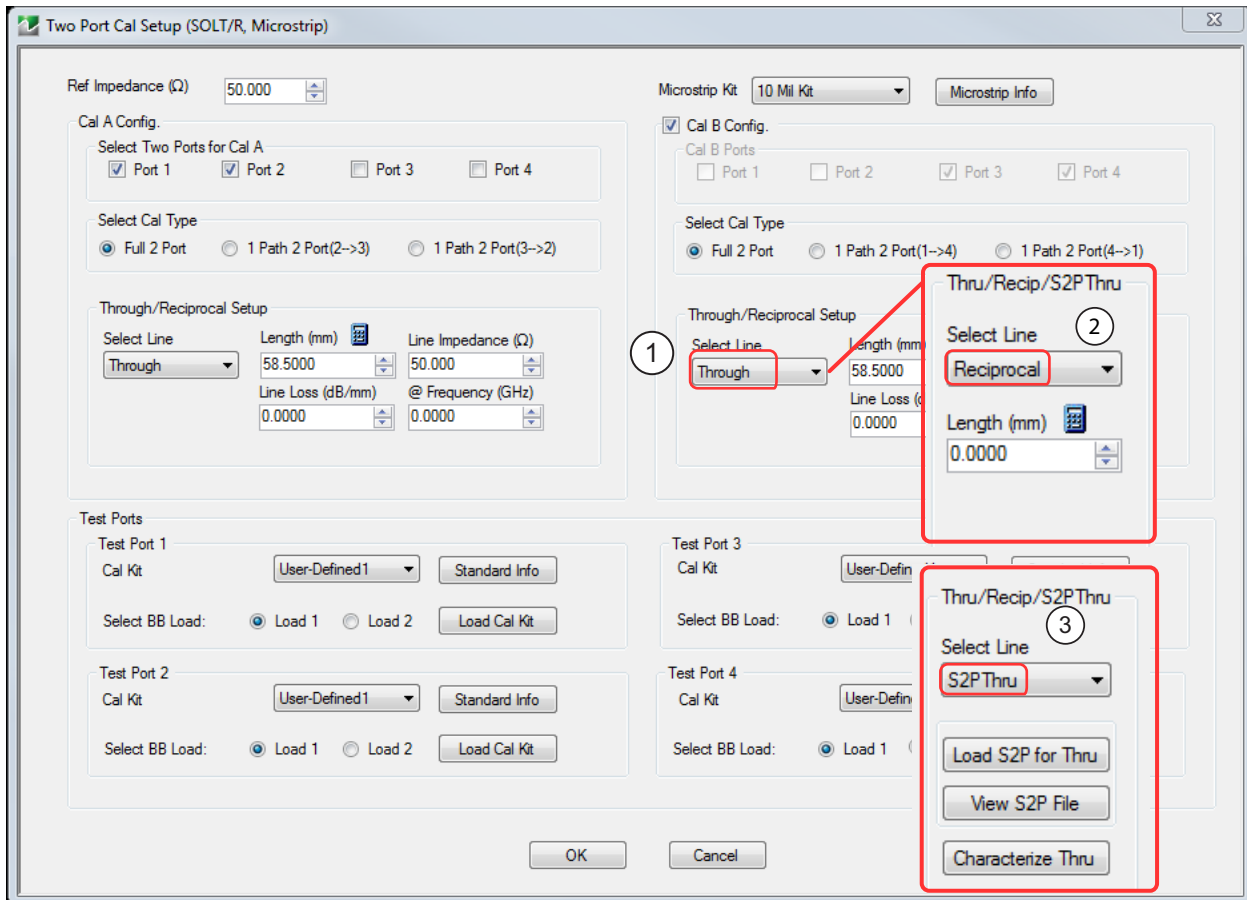

1. Through Line selected allows user entries for length, line impedance, line loss and frequency.
2. Reciprocal selected allows user entry for length.
3. S2P Thru selected provides buttons for loading, viewing, and characterization (to generate S2P files).

Figure 3-3. TWO PORT CAL SETUP (SOLT/R, MICROSTRIP) Dialog Box

The standards information dialog for SOLT/R is shown in Figure 3-4.

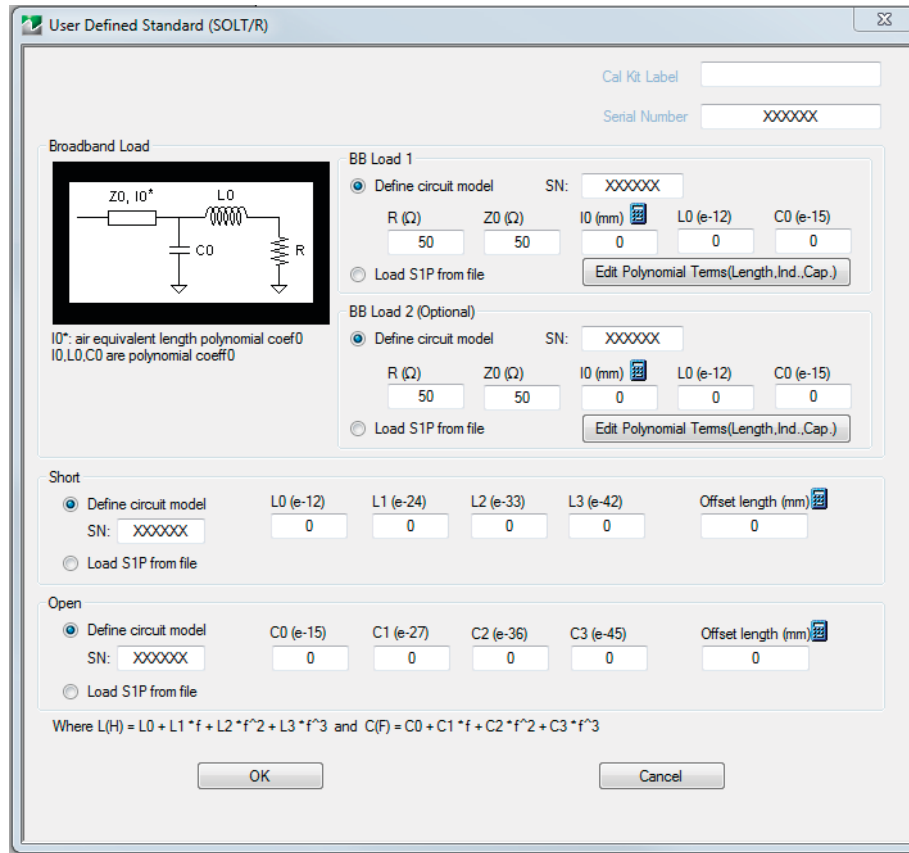
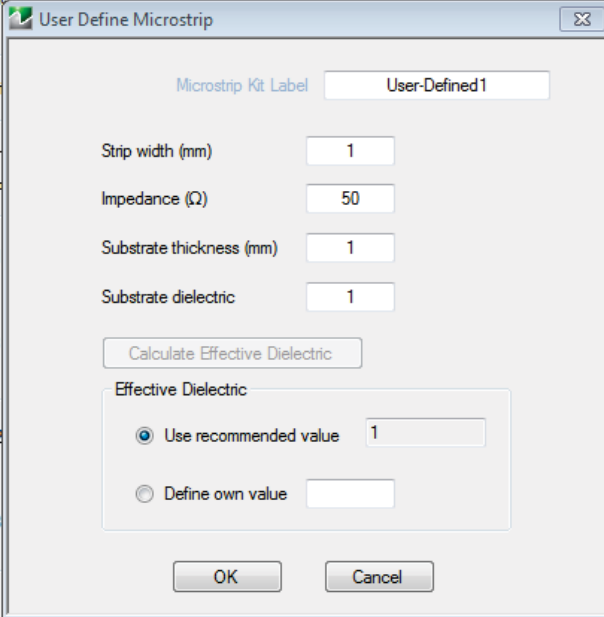

Figure 3-4. STANDARD INFO (SOLT/R)

For cal kits loaded from Anritsu cal kit files, the model terms are not editable. When using user-defined cal kits, the model terms can be edited.

The standards information for microstrip does not change but the microstrip media information must be either user-defined (Figure 3-5) or selected from an Anritsu microstrip cal kit (Figure 3-6, typically used with Anritsu Universal Test Fixtures).



The 'User Define Microstrip' dialog box contains the following fields and controls:

- Microstrip Kit Label: User-Defined1
- Strip width (mm): 1
- Impedance (Ω): 50
- Substrate thickness (mm): 1
- Substrate dielectric: 1
- Calculate Effective Dielectric button
- Effective Dielectric section:
 - Use recommended value: 1
 - Define own value: [empty]
- OK and Cancel buttons

Figure 3-5. USER-DEFINED MICROSTRIP Data Input Dialog Box

Effective dielectric constants can be entered, or the recommended value can be selected.

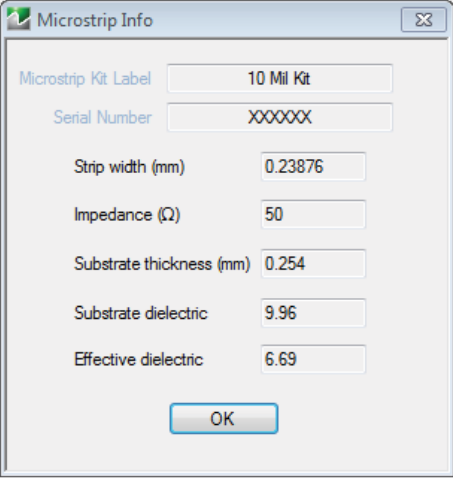

The 'Microstrip Info' dialog box displays the following information:

- Microstrip Kit Label: 10 Mil Kit
- Serial Number: XXXXXX
- Strip width (mm): 0.23876
- Impedance (Ω): 50
- Substrate thickness (mm): 0.254
- Substrate dielectric: 9.96
- Effective dielectric: 6.69
- OK button

Figure 3-6. MICROSTRIP INFO 10 Mil Kit Dialog Box

For waveguide, the model parameters and the media parameters are combined in one dialog ([Figure 3-7](#)).

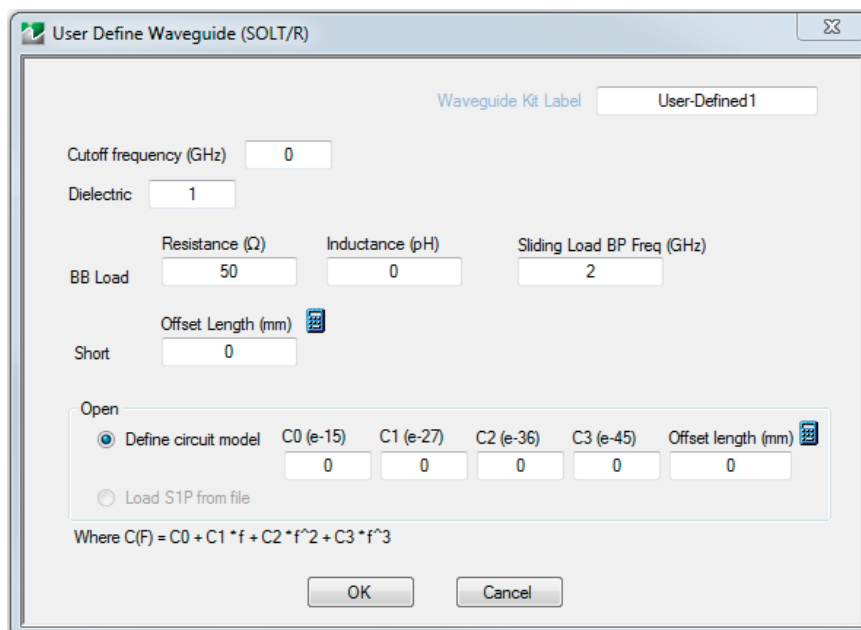

Figure 3-7. USER-DEFINED WAVEGUIDE (SOLT/R) Information Dialog Box

3-4 SOLT/SOLR Calibration

The following example presumes an MS46322B Series VNA with K or N connectors. A different connector can be selected in step 4 if a different model/configuration is being used. It is assumed that a M-F cable is connected to port 2 so that a M (port 1) and F (port 2) reference plane pair is available. In this example, a full 2-port SOLT calibration will be performed, although a number of other options are discussed along the way. The implications of these options are discussed in the calibration overview section.

1. Setup the desired frequency range (FREQUENCY menu), power (POWER menu) and IFBW/averaging (AVERAGING menu). As a default, the IFBW will be 1 kHz and the averaging will be off which is adequate for many applications. The default power level will vary depending on instrument model and options but will often be adequate for all passive and many active device measurements.
2. Navigate to the TWO PORT CAL menu.
 - MAIN | Calibration | CALIBRATION | Calibrate | CALIBRATE | Manual Cal | MANUAL CAL | 2-Port Cal | TWO PORT CAL

Note If a previous calibration exists, the Thru Update button will be active.

3. Select Modify Cal Setup. The CAL SETUP menu appears. On this level, select a cal method of SOLT/SOLR and a line type of Coaxial.
4. Select Edit Cal Params; the TWO PORT CAL SETUP (SOLT/R, COAXIAL) dialog box appears [Figure 3-8](#) which describes the calibration components:
 - a. Reference impedance defaults to 50 ohms. This value is used for referencing the standards reflection coefficients and for reference plane shift and Smith chart calculations. The latter two items can be handled later using a per-trace definition of reference impedance. The standards definition process is not affected by that later per-trace reference impedance change.
 - b. In the Load Type area, select broadband load. A sliding load can be used for better performance if one is available in the calibration kit. If low frequencies are included in the frequency range (< 2 GHz for K or GPC3.5), then a broadband load will be used in addition to the sliding load.
 - c. In the Through/Reciprocal area, a zero-length (or mating) thru will be used. Set the Select Line field to Through, 0 mm for the length and 0 dB/mm loss. Zero can also be entered for the reference frequency. When 0 is entered for this value, no loss scaling is employed and the entered loss value is used for all frequencies. If a reciprocal network was being used instead of a through, use Reciprocal for the Select Line field and the length entered would serve as an estimate for root choice purposes.
 - d. For **Port 1**, select a DUT connector of N(f). Note the dialog will then indicate that port connector is N(m).
 - e. For **Port 2**, select a DUT connector of N(m). The dialog will indicate a port connector of N(f).
 - f. For both ports, select a BB load of Load 1. This selection is for certain firmware/cal kit versions where modeled loads are available and the distinction between loads is important.
 - g. Select OK to close the dialog. Select Back at the bottom of the menu to return to the previous level and the TWO PORT CAL menu where two Reflective Devices buttons appear with six reflection standards on the two submenus.

Note The menu calibration steps can be performed in any order. For this example, a top to bottom menu approach is assumed.

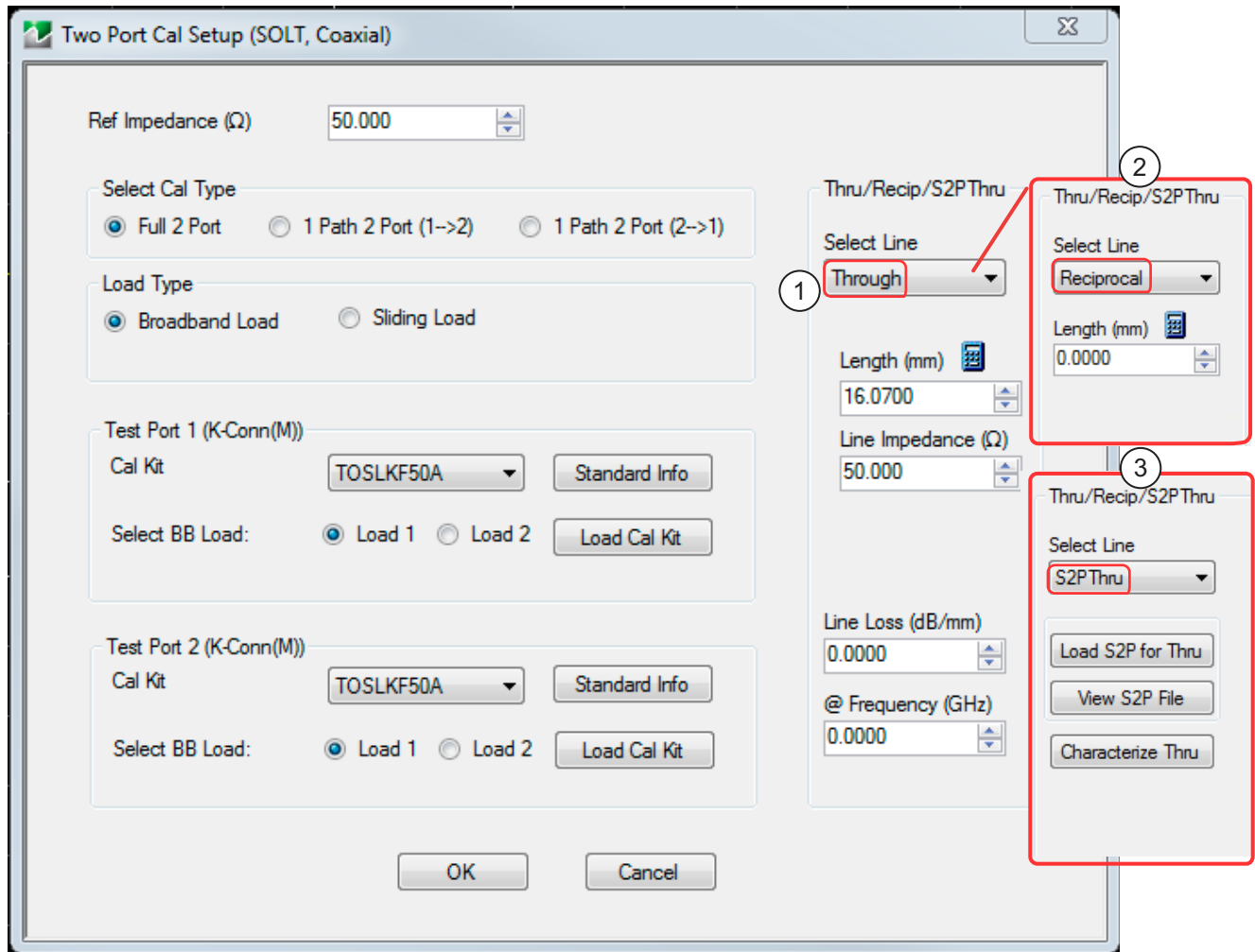

1. Through Line selected allows user entries for length, line impedance, line loss and frequency.
2. Reciprocal selected allows user entry for length.
3. S2P Thru selected provides buttons for loading, viewing, and characterization (to generate S2P files).

Figure 3-8. TWO PORT CAL SETUP (SOLT/R, COAXIAL) Dialog Box

5. Select Port 1 Reflective Devices and the REFL. DEVICES PORT 1 menu. On the menu, measure the three reflection standards of Open, Short, and Load. Connect each standard in turn, and THEN, click the corresponding button. When all are done, click the Back button to return to the TWO PORT CAL menu.
6. Then select Port 2 Reflective Devices and the REFL. DEVICES PORT 2 menu where next three reflection standards are listed. When all six are done (and six check marks appear), click Done to return to the previous level and the TWO PORT CAL menu.
7. After measuring all six reflection standards, connect the cable to **Port 1** to complete the zero length through. Now click on the Thru/Recip button where a check mark should appear after the sweep pair. Note that the displayed graphs may change during this step as the instrument must measure all four S-parameters of the thru line.
8. An optional isolation step using the Isolation (Optional) button and the linked ISOLATION menu is available but is generally not recommended. If desired, terminate **Port 1** and the end of the cable attached to **Port 2** before clicking on the Isolation (Optional) button if needed.

9. Click on Done. The calibration is now completed and turned on where the Cal Status button on the CALIBRATION menu is set to ON.

Chapter 4 — Offset Short (SSLT) Calibration

4-1 SSLT Introduction

This chapter describes calibration methods and procedures using the SSLT calibration algorithm.

The SSLT calibration differs from an SOLT/SOLR (SOLT/R) calibration by the differing offset lengths between two shorts which are used to help define reflection behavior instead of an open and short. Because of this, the frequency range is limited since, at DC and at higher frequencies, these reflect standards will look the same. This method is most commonly used for waveguide problems where creating a stable, high reflection open standard is difficult, but there are certain coax and board-level or wafer-level situations where it is useful. The modeling constructs are about the same as for an SOLT/SOLR calibration. From an error term perspective, the only difference is that the two shorts together now largely determine source match and reflection tracking behavior.

The electrical length difference between the shorts should be between 20 and 160 degrees over the frequency range of interest.

The top calibration kit definition dialog box for SSLT calibration is identical to the SOLT/R dialog (Figure 4-3). The standards information dialog box is different and is shown below.

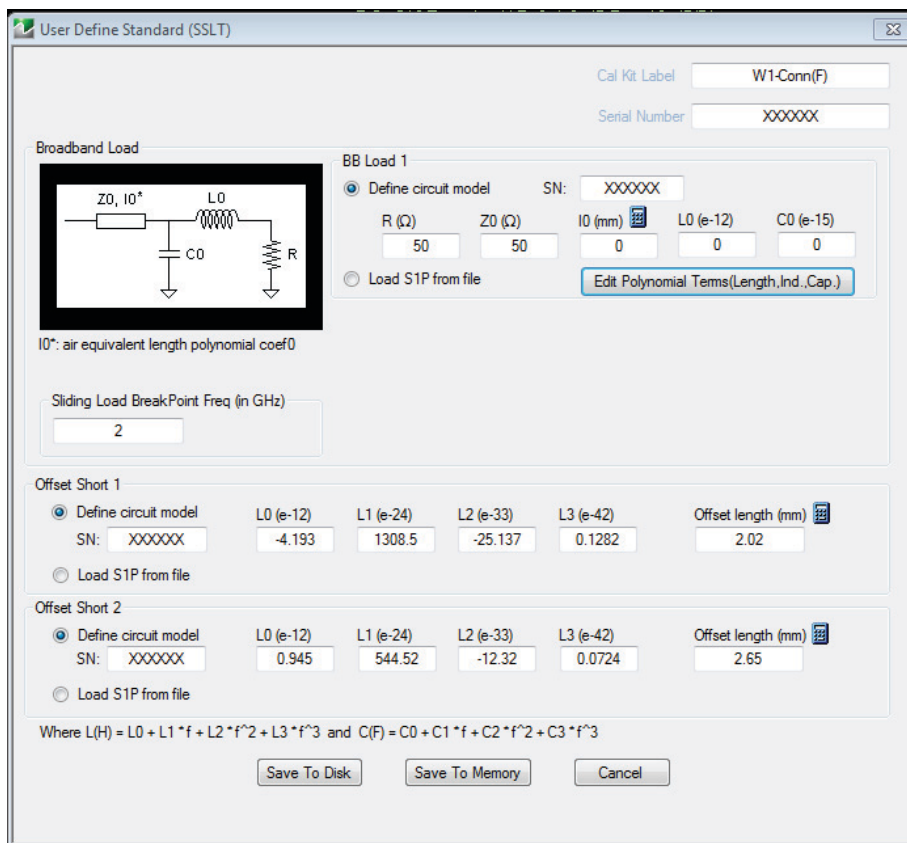
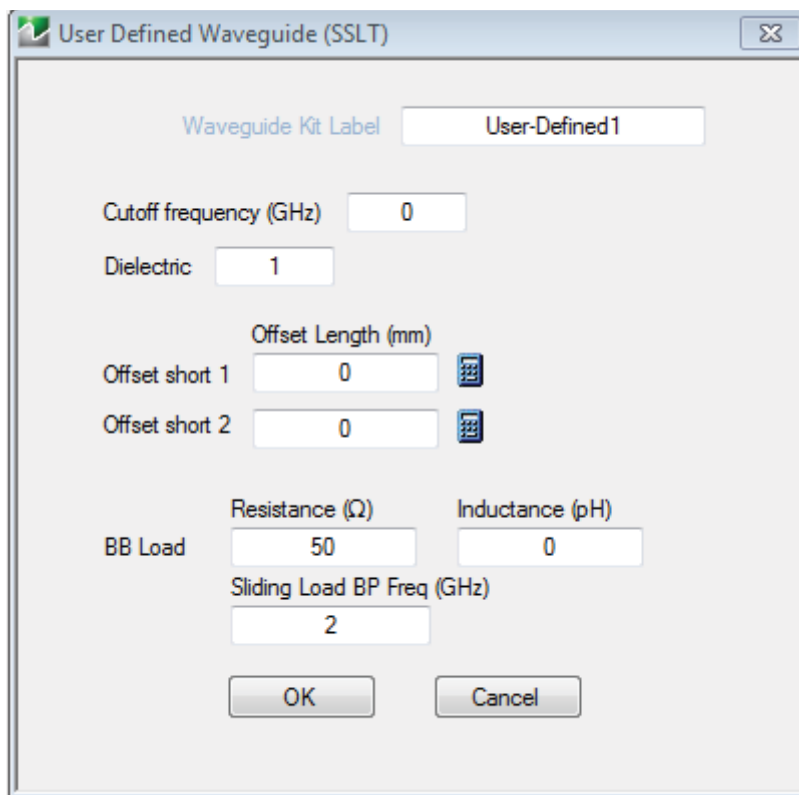

Figure 4-1. STANDARD (OFFSET SHORT) Information Dialog Box

Variations for other line types (waveguide or microstrip) are similar to those for SOLT/R. For waveguide, the media and standards information are combined as shown in Figure 4-2. Defined, un-editable values would be present for Anritsu-defined cal kits.



The screenshot shows a dialog box titled "User Defined Waveguide (SSLT)". It contains the following fields and values:

- Waveguide Kit Label: User-Defined1
- Cutoff frequency (GHz): 0
- Dielectric: 1
- Offset Length (mm): 0
- Offset short 1: 0
- Offset short 2: 0
- BB Load Resistance (Ω): 50
- BB Load Inductance (pH): 0
- Sliding Load BP Freq (GHz): 2

Buttons for "OK" and "Cancel" are located at the bottom of the dialog.

Figure 4-2. Typical parameters for an Offset Short Calibration

A simplified short model is used for waveguide, with only an offset length and no inductance terms since usually those terms are small.

4-2 SSLT Calibration Example

The following example presumes a MS46122A/B, 131A, 322A/B, ME7868A is being used with waveguide adapters (since SSLT is commonly used with waveguide). In this example, a full 2-Port SSLT calibration is performed although a number of other options are available. The implications of these options are discussed in the calibration overview section.

Set the desired frequency range (Frequency menu), and IFBW/Averaging (Averaging menu). The default power level varies depending on the instrument model and options, but will often be adequate for all passive and many active device measurements. The default IFBW is 1 kHz with averaging off, which is adequate for many applications.

1. Navigate to the TWO PORT CAL menu.

- MAIN | Calibration | CALIBRATION | Calibrate | CALIBRATE | Manual Cal | MANUAL CAL | 2-Port Cal | TWO PORT CAL

Note If a previous calibration exists, the Thru Update button will be active.

2. Select Modify Cal Setup, then on the CAL SETUP menu, select a Cal Method of SSLT and a Line Type of Waveguide.

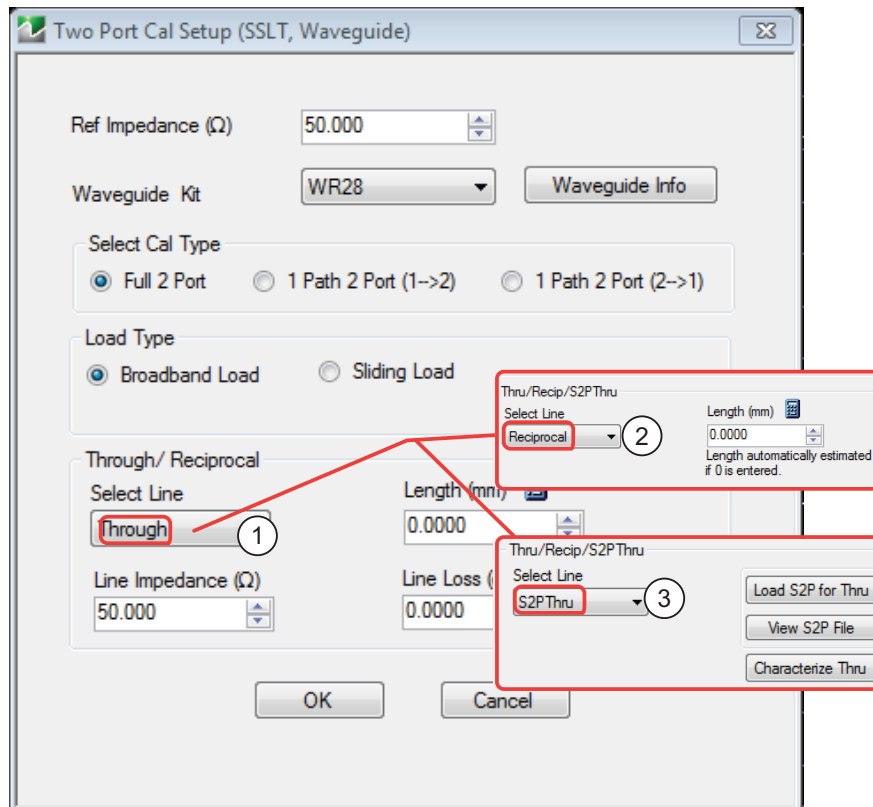

1. Through Line selected allows user entries for length, line impedance, line loss and frequency.

2. Reciprocal selected allows user entry for length.

3. S2P Thru selected provides buttons for loading, viewing, and characterization (to generate S2P files).

Figure 4-3. TWO PORT CAL SETUP (SSLT, WAVEGUIDE) Dialog Box

3. Select Edit Cal Params which will displays the TWO PORT CAL SETUP (SSLT, WAVEGUIDE) dialog box describing the calibration components (shown above).

- a. Reference impedance defaults to 50 ohms. Although this does not represent the waveguide impedance, it is commonly used for conventional Smith chart referencing. Reference impedance can be changed here for certain waveguide applications or it can be changed later on a per trace basis from the DISPLAY menu.
 - b. Select **Broadband Load**. A sliding load can be used for better performance if one is available in the calibration kit. If low frequencies are included in the frequency range (< 2 GHz), then a broadband load will be used in addition to the sliding load.
 - c. A zero-length (or mating) thru will be used so enter **Through** for the line, 0 mm for the length and 0 dB/mm loss. Zero can be entered for the reference frequency when no loss scaling is employed and the entered loss value is used for all frequencies. **Reciprocal** is not available at this time.
 - d. For a waveguide kit, select **WR42** (for this example). A user-defined kit can be selected from the pull-down menu, but the cutoff frequency, the dielectric, the short offset lengths, and the load impedance (relative to the reference impedance) will have to be specified.
 - e. Select **OK** to close the dialog, then select **Back** at the bottom of the menu to return to the previous level and the **TWO PORT CAL** menu.
4. The **Port 1 Reflective Devices** and the **Port 2 Reflective Devices** buttons display the **REFL. DEVICES PORT 1** and **PORT 2** menus. The six reflection standards to be measured (Short 1, Short 2, Load on each menu) will be displayed here along with the read-only fields showing the port connector choices. Connect each standard in turn, and **THEN** click the corresponding button. When all six are done (and six check marks appear), click **Done** to return to the previous level and the **TWO PORT CAL** menu.
 5. After measuring all six reflection standards, connect the test cable to **Port 1** to complete the zero length through. Click on the **Thru/Recip** button to display the **THRU/RECIP** menu where a check mark should appear after the sweep pair. Note that the displayed graphs change during this step as the instrument must measure all four S-parameters of the through line.
 6. An optional isolation step is available, but is not recommended. If desired, terminate **Port 1** and the end of the cable attached to **Port 2** before clicking on the **Isolation (Optional)** button and displaying the **ISOLATIONS** menu.
 7. When all steps are successfully completed, the **Done** button is available where select returns to the **CALIBRATION** menu where the **Cal Status** button is set to **ON**.
 8. The calibration is now completed and turned on.

Chapter 5 — Triple Offset Short (SSST) Calibration

5-1 SSST Introduction

This chapter describes calibration using the triple offset short (SSST) algorithm. The next step in this progression is to remove the load so that the entire reflection space is defined by three shorts of varying offset lengths. The individual short definitions are the same as for an SOLT/SOLR calibration.

5-2 SSST and Reflectivity Error Terms

With an SSST calibration the three shorts together determine all of the reflectivities error terms (directivity, source match and reflection tracking). This calibration is more band-limited than the double offset short method. If short1 is defined as having the smallest offset length, and short3 to the longest offset length, then two variables can be defined:

$$A = L_{\text{offset_short2}} - L_{\text{offset_short1}}$$
$$B = L_{\text{offset_short3}} - L_{\text{offset_short2}}$$

Equation 5-1.

The electrical length equivalents of A and B should generally be between 20 and 85 degrees over the frequency range of interest. This is not sufficient in itself since one will also require that A+B (which represents the difference between short1 and short3) also be constrained:

$$40 < \frac{720 \cdot f \cdot B}{v_{ph}} < 180$$
$$40 < \frac{720 \cdot f \cdot A}{v_{ph}} < 180$$
$$40 < \frac{720 \cdot f \cdot (A + B)}{v_{ph}} < 320$$

Equation 5-2.

Since the only standards needed are shorts, this method is attractive for millimeter wave applications and for certain board-level and wafer-level calibrations where other types of standards are difficult to manufacture.

The setup and standards information dialogs for SSST are shown in Figure 5-1 and Figure 5-2 for a 2-Port calibration.

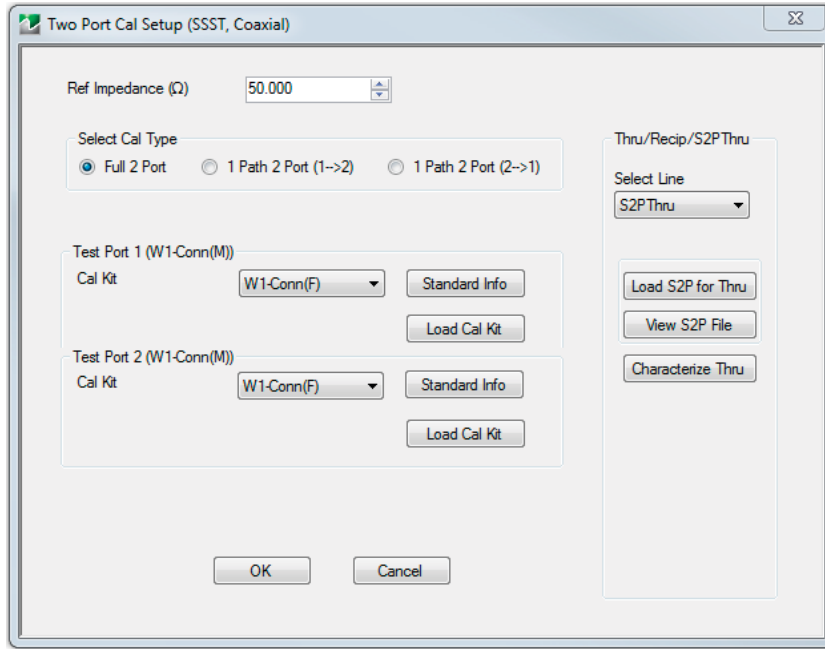

Figure 5-1. TWO PORT CAL SETUP (SSST, COAXIAL)

For one port calibrations, only one of the port definitions (unless reflection-only calibrations are being performed for both ports 1 and 2) will be present and the through line section will not be present. For a 1 path-2 port calibration, one of the port definition sections will not be present.

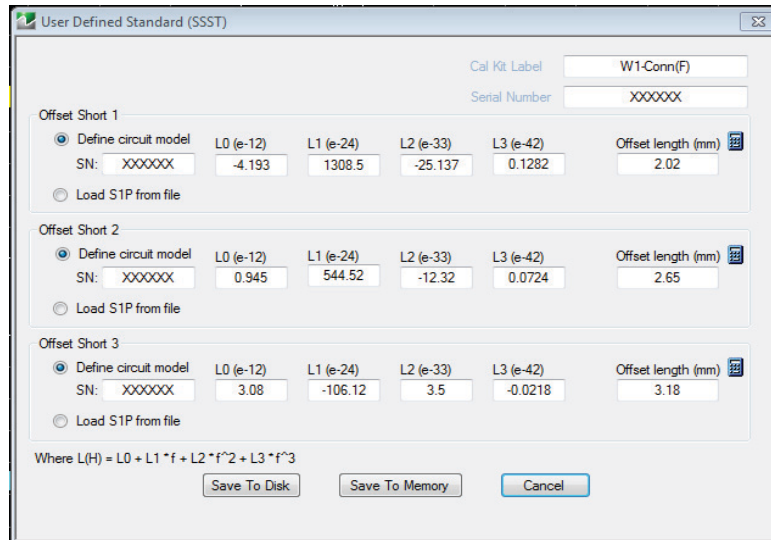
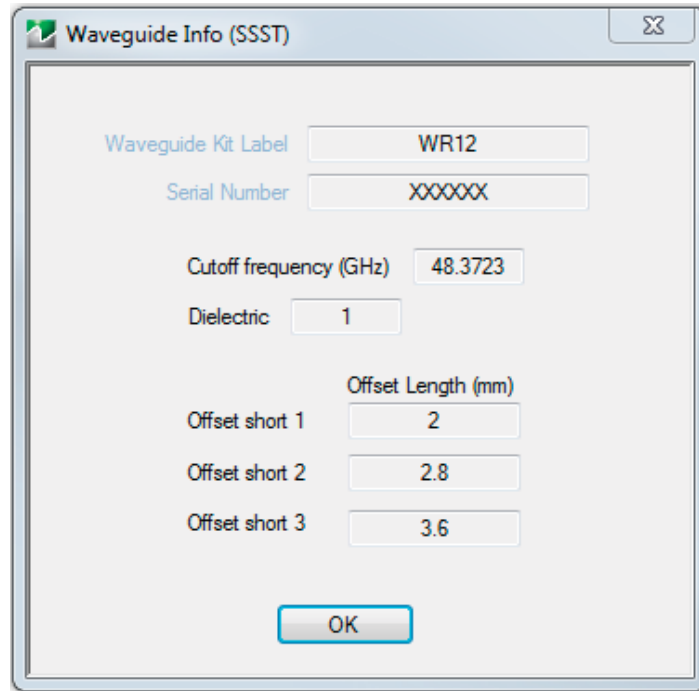

Figure 5-2. STANDARD INFO (TRIPLE OFFSET SHORT) Information Dialog Box

Variations for other line types are similar to those for SOLT/R. For waveguide, the media and standards information are again combined into one dialog (Figure 5-3).



The image shows a software dialog box titled "Waveguide Info (SSST)". It contains several input fields for user-defined parameters:

- Waveguide Kit Label: WR12
- Serial Number: XXXXXX
- Cutoff frequency (GHz): 48.3723
- Dielectric: 1
- Offset Length (mm) section with three rows:
 - Offset short 1: 2
 - Offset short 2: 2.8
 - Offset short 3: 3.6

An "OK" button is located at the bottom center of the dialog.

Figure 5-3. USER DEFINED WAVEGUIDE (SSST) Information Dialog Box

5-3 SSST Calibration Example

The following example presumes an MS46122A/B or MS46322A/B Series VNA in a broadband setup with K connectors. A different connector can be selected in [Step 4](#) below if a different model/configuration is being used. It is assumed that a M-F cable is connected to Port 2 so that a M (port 1) and F (port 2) reference plane pair is available.

In this example, a full 2-Port SSST calibration will be performed although a number of other options are discussed along the way. These options are discussed in the Calibration Overview section.

1. Set the desired frequency range (FREQUENCY menu), and IFBW/Averaging (AVERAGING menu). The default power level varies depending on the instrument model and options, but will often be adequate for all passive and many active device measurements. The default IFBW is 1 kHz with averaging off, which is adequate for many applications.
2. Navigate to the TWO PORT CAL menu.
 - MAIN | Calibration | CALIBRATION | Calibrate | CALIBRATE | Manual Cal | MANUAL CAL | 2 -Port Cal | TWO PORT CAL

Note If a previous calibration exists, the Thru Update button will be active. See the Calibration Overview section for more information.

3. Select Modify Cal Setup, and on the CAL SETUP menu, select a Cal Method of SSST and a Line Type of Coaxial.
4. Select Edit Cal Params, the TWO PORT CAL SETUP (SSST, COAXIAL) dialog box appears (shown below).

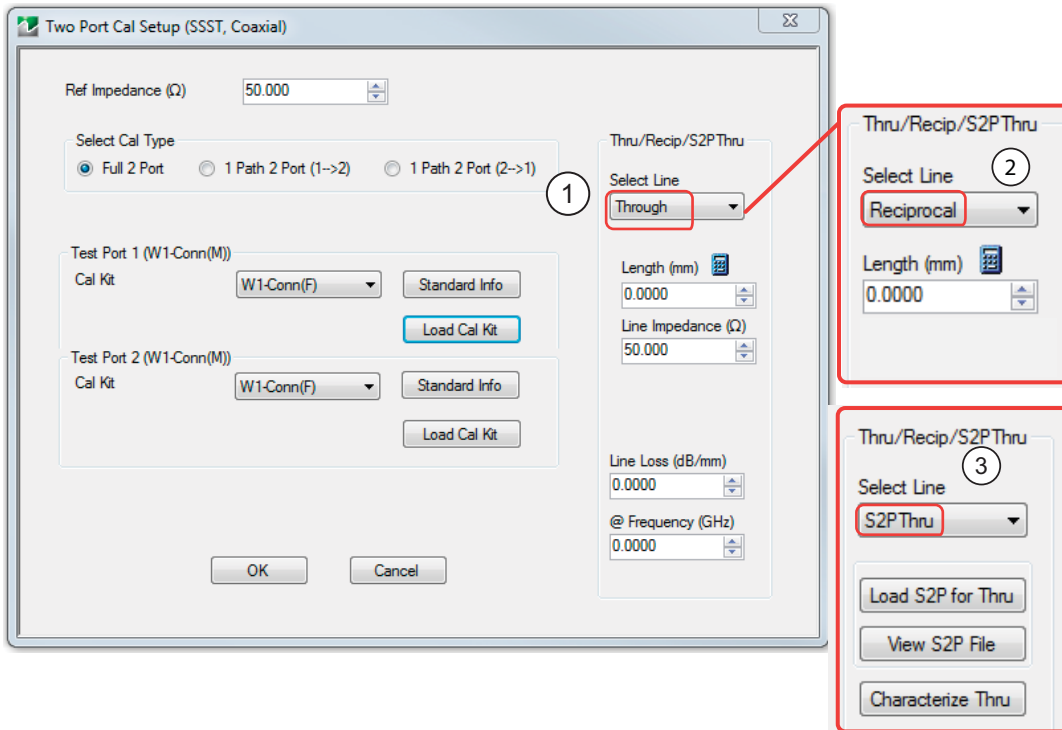

1. Through Line selected allows user entries for length, line impedance, line loss and frequency.
2. Reciprocal selected allows user entry for length.
3. S2P Thru selected provides buttons for loading, viewing, and characterization (to generate S2P files).

Figure 5-4. TWO PORT CAL SETUP (SSST, COAXIAL)

5. In the TWO PORT CAL SETUP (SSST, COAXIAL) dialog box, set the following calibration components:
 - a. Reference impedance defaults to 50 ohms. This establishes the reference impedance for reference plane changes and Smith chart plotting but can be changed later on a per-trace basis.
 - b. In the Select Cal Type area, select the Full 2 Port radio button.
 - c. A zero-length (or mating) thru will be used so enter Through for the line, 0 mm for the length and 0 dB/mm loss. Zero can be entered for the reference frequency when no loss scaling is employed and the entered loss value is used for all frequencies. Reciprocal is not available at this time.
 - d. For **Test Port 1**, select a DUT connector of K(f). The dialog box then displays a port connector as W1-Conn (m).
 - e. For **Test Port 2**, select a DUT connector of K(m). The dialog box then displays a port connector as W1-Conn (f).
 - f. Click OK to close the dialog. Select Back at the bottom of the menu to return to the previous level and the TWO PORT CAL menu.
6. The Port 1 Reflective Devices and the Port 2 Reflective Devices buttons display the REFL. DEVICES PORT 1 and PORT 2 menus. The six reflection standards to be measured (Short 1, Short 2, Short 3 on each menu) will be displayed here along with the read-only fields showing the port connector choices. Connect each standard in turn, and then click the corresponding button. When all six are done (and six check marks appear), click Done to return to the previous level and the TWO PORT CAL menu.
7. After measuring all six reflection standards, connect the test cable to **Port 1** to complete the zero length through. Click on the Thru/Recip button to display the THRU/RECIP menu where a check mark should appear after the sweep pair. Note that the displayed graphs change during this step as the instrument must measure all four S-parameters of the through line.
8. An optional isolation step is available, but is not recommended. If desired, terminate **Port 1** and the end of the cable attached to **Port 2** before clicking on the Isolation (Optional) button and displaying the ISOLATIONS menu.
9. When all steps are successfully completed, the Done button is available where select returns to the CALIBRATION menu where the Cal Status button is set to ON.
10. Click Done. The calibration is now completed and turned on.

Chapter 6 — LRL/LRM Calibration

6-1 LRL/LRM Introduction

This chapter describes LRL/LRM calibration algorithms and procedures. The LRL/LRM family of calibrations relies more on the fundamental behavior of certain components (primarily transmission lines) than it does on characterized/modeled behaviors of components. It makes less use of redundancy, so fewer measurements are needed to complete a calibration, but it is also less tolerant of poor or non-repeatable measurements.

Note SOLR and LRL/LRM calibration methods are available with the “B” models only.
--

6-2 LRL/LRM Comparison

LRL — Line-Reflect-Line

LRL (Line-Reflect-Line) uses two (or more) transmission lines and a reflect standard (for each port). The line lengths are important as it is required that the two lines look electrically distinct at all times (meaning it will not work at DC nor at a frequency where the difference in length is an integral number of half wavelengths). The reflect standard is assumed to be symmetric and without a high return loss. The lines are assumed perfect (no mismatch), and are usually airlines for coaxial calibrations, although other structures can be used. On-wafer transmission lines can be very good and this calibration approach will work well if the required probe movement can be managed.

LRM — Line-Reflect-Match

LRM (Line-Reflect-Match) calibrations have one of the lines above replaced with a match (or load). The load is modeled/characterized (or assumed perfect). Since only one line is involved, this calibration can work down to DC and up to very high frequencies (practically limited by the match knowledge/characterization). Variations allow one of the match measurements to be traded for a pair of additional reflect measurements (a second reflect standard is needed). Because of the requirement that the reflect standards be distinct, the calibration may become band limited.

In the limiting case of a match that is assumed perfect, or at least assumed symmetric, this calibration reduces to the classical LRM. The added flexibility is in the ability to define asymmetric load models and to use multiple reflect standards as discussed above. The double reflect methodology allows one to feed into a load modeling utility where the load model can be further optimized.

Some parameters to keep in mind:

Line Lengths

In addition to the LRL frequency limits, the line length is used for some reference plane tasks. The fundamental reference plane of an LRL calibration is in the middle of the first line. If the reference plane is required at the ends of this line, the line length (and loss which can also be entered) is used to rotate the reference planes to the desired location. The line length delta is also used for some root choice tasks, although the accuracy required on this entry is less.

Line Length Delta

As mentioned above, the usable frequency range for LRL is set by the line length delta. Strictly speaking, the electrical length should be between 0 and 180 degrees for all frequencies of interest although some margin is usually desired to account for line parasitics, spurious mode launches and other problems. In general, the delta should be kept between 10 and 170 degrees or 20 and 160 degrees. Practically speaking, one can usually be more aggressive on the lower number and will want to be less aggressive on the upper number:

$$10 < \frac{360 \cdot f \cdot \Delta L}{v_{ph}} < 160$$

Equation 6-1

Where ΔL is in meters, v_{ph} is the phase velocity of the line ($= 2.9978 \cdot 10^8 \text{ m/s} = c$ for air dielectric) and f can be any frequency in the range of interest, expressed in Hz.

If this range is too small for the application, multiple lines and multiple bands can be used, which will be discussed shortly. The single-band version of the dialog is highlighted in [Figure 6-1 on page 6-3](#). Two devices must be defined and the first (Cal Device X) must be a line which has a length associated with it in millimeters (air equivalent) or in picoseconds of delay. Note that the Cal Device X in the first band has an added role when the reference plane choice 'Ends of Line 1' is selected. The length of this Cal Device X will be rotated out from the final error coefficients to place the reference planes at its ends. The basic LRL/LRM algorithm places the reference plane in the middle.

A loss and frequency dependence for the line can be optionally specified (loss defaults to 0 dB). The loss is in per-unit-length terms and can be assumed flat with frequency by entering 0 in the frequency field. If a non-zero value is entered, the loss value entered is assumed to be at that frequency and a square-root-of- f scaling will be used at other frequencies. In other words, if the loss K is entered at frequency f_0 then the value at frequency f_1 will be computed as:

$$Loss_at_f_1 = K \sqrt{\frac{f_1}{f_0}}$$

Equation 6-2.

The second device (Cal Device Y) can either be another line or a match. If another line, its length/delay should be entered, although this value will be primarily used to help with root choice. The loss values for Cal Device X will be used for Cal Device Y. If the second device is a match, the model for that match may be entered using the sub-dialog (assumed infinite return loss by default). The entered load model is only then used for the first part of the calculation to help the optimizer more quickly generate a better fit for the simplified match model. Also, only one of the match measurements is needed for this algorithmic variant and the match to be used is selected in the sub-dialog.

Two Port Cal Setup (Coaxial)

Ref Impedance (Ω) 50.000 Dielectric 1.000649

Reference Plane Location
 Ends of Line 1 Middle of Line 1

Line Length Representation
 Eff. Length Delay Phy. Length

Band Definition
 Number of Bands: 1

Band # (Device #)	Cal Device X	Device X Eff. Length (mm)	Cal Device Y	Device Y Eff. Length (mm)/ Match	Loss (dB/mm)	@Frequency (GHz)	Reflection Type	Breakpoint (GHz)	Breakpoint Calculation
1 (X=1, Y=2)	Line	0	Line	5	0	0	Short-like		

Reflection Component (Note: Reflection offset length is referenced from the Ends of first line)
 Open-like Offset Length (mm) 0.0000 Short-like Offset Length (mm) 0.0000

Last Loaded Kit Name
 Save Kit Load Kit Restore Defaults OK Cancel

Typical parameters - One-Band LRM calibration

Figure 6-1. TWO PORT CAL SETUP (LRL/LRM, COAXIAL) Dialog Box

Because of the phase restrictions discussed above, each LRL calibration is fundamentally band-limited to something on the order of an 8:1 to 17:1 frequency range (and some users may restrict it further for measurements requiring very low uncertainties when the line losses are low). To cover wider frequency ranges and to, for example, use LRM for part of the frequency range, the concept of Multiband LRL was generated. Various combinations of standards (staying within the LRL/LRM family) can be used to cover multiple bands and hence cover the extended range. The concept of the 'breakpoint frequency' is needed that defines when the calibration coefficients are taken from the lower band measurements and when they are taken from the upper band measurements. This process does not affect how the measurements are done. It just changes which data (from an over-determined set) is used to compute the calibration coefficients. The calibration process is optimized so that if a particular standard is used in multiple bands, it only needs to be measured once.

The setup dialog is shown in [Figure 6-2 on page 6-5](#) with the maximum of 5 allowed bands selected. In some sense, each band is a new LRL/LRM calibration covering some subset of the desired frequency range. All of the bands share the same open-like and short-like reflects although one can choose between those two independently in each band (or use both for in any band). In each band, one must choose two lines or one line and a match and those devices can be shared amongst the bands. As an example, it is not unusual to share one line in all of the bands and then the 2nd line in each band is chosen to create an ever-decreasing ΔL as the band number increases (thus each subsequent band is to be used in a higher frequency sub-range). In the higher numbered bands, any devices in the previous bands can be used. Note that loss entries are local to a band in order to allow the user to correct for deviations from the square-root-of- f loss frequency dependence model.

To illustrate a multi-band setup, we will work through a design example where the calibration range is to be 200 MHz to 70 GHz and we wish to not exceed 20 to 160 degree relationships and do the calibration with only LRL using air dielectric lines. Since the high-to-low ratio is less than 8^3 the calibration can be accomplished in 3 bands under these conditions. It is desired to use a common line of length 10 cm for all bands.

If the first band must work down to 200 MHz with a 20 degree ΔL limit, then the first $\Delta L=8.333$ cm so the second line should be 18.333 cm long. This first band, using the 160 degree limit, should be able to reach 1.6 GHz. To allow some band overlap (and improve uncertainties a bit more), we will choose the 20 degree lower limit of the second band to be a bit lower than 1.6 GHz and select 1.4 GHz. This implies a second ΔL of 1.19 cm. Since we wish to re-use the 10 cm line in this band, the second line in the second band should be 11.19 cm long with a 160 degree-based frequency limit of 11.2 GHz. For the third band, we will again aim for a value under the previous band's 160 degree limit and select 10 GHz. This leads to a third ΔL of 1.67mm or a final line length of 10.167 cm.

Summarizing:

BAND 1:	Cal Device X 10 cm line	Cal Device 18.333 cm line	
BAND 2:	Cal Device (use band 1 Dev X)	Cal Device Y 11.19 cm line	Breakpoint: 1.497 GHz
BAND 3:	Cal Device X (use band 1 Dev X)	Cal Device Y 10.167 cm line	Breakpoint: 10.58 GHz

In this full calibration example, there are a total of four lines to be measured (along with whatever reflect standard(s) was (were) selected). Although not all of the frequency range data for each device will be used (e.g., band 2 Cal Device Y data for frequencies below 1.497 GHz or above 10.58 GHz will not be used), all devices will be swept over the whole calibration frequency range in order to simplify sweep control and minimize overhead.

Here the breakpoints were calculated off-line using the geometric mean of the upper limit of the lower band and the lower limit of the upper band. The recommended values that would be generated by the instrument would be different since it uses the 10 to 160 degree process instead of the 20 to 160 degree limit we selected for this example. These slight shifts in breakpoint will generally have limited effect of the results (<0.03 dB error generally at the breakpoint in this case) but if one gets more aggressive with the angle limits, errors can increase. This is less true if the lines are lossy (as in a PC board environment) than if the losses are very low.

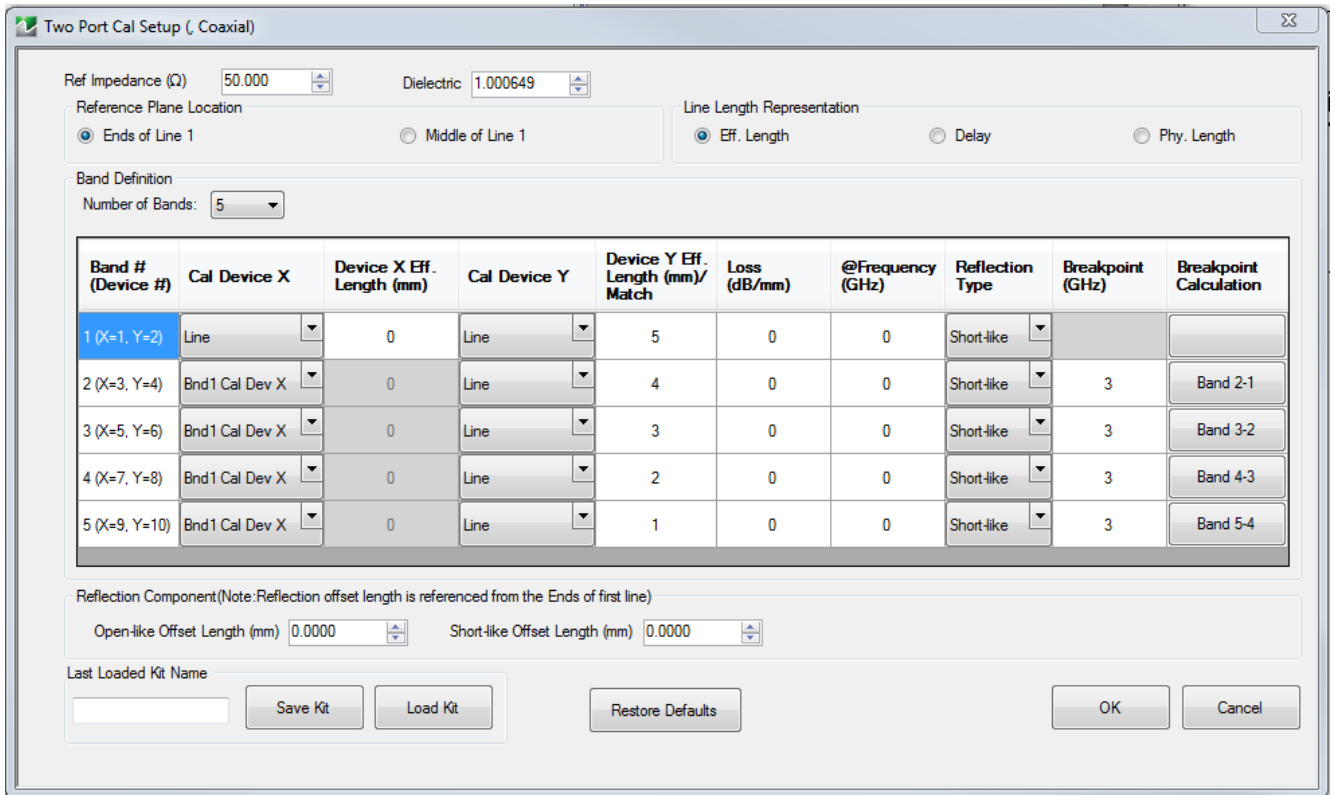

Typical parameters - Bands 1, 2, and 4: LRL, Bands 3 and 5: LRM

Figure 6-2. TWO PORT CAL SETUP (LRL/LRM, COAXIAL) Dialog Box

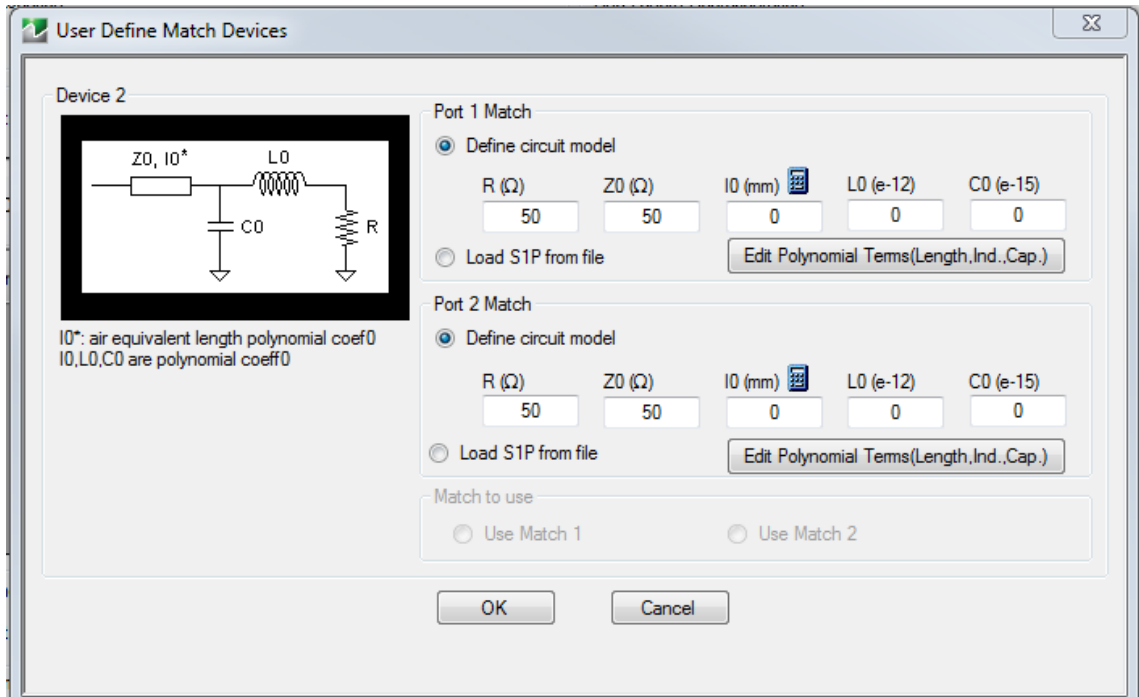

Typical parameters - Defining the Load for LRM (match info)

Figure 6-3. USER DEFINED MATCH DEVICES Dialog Box

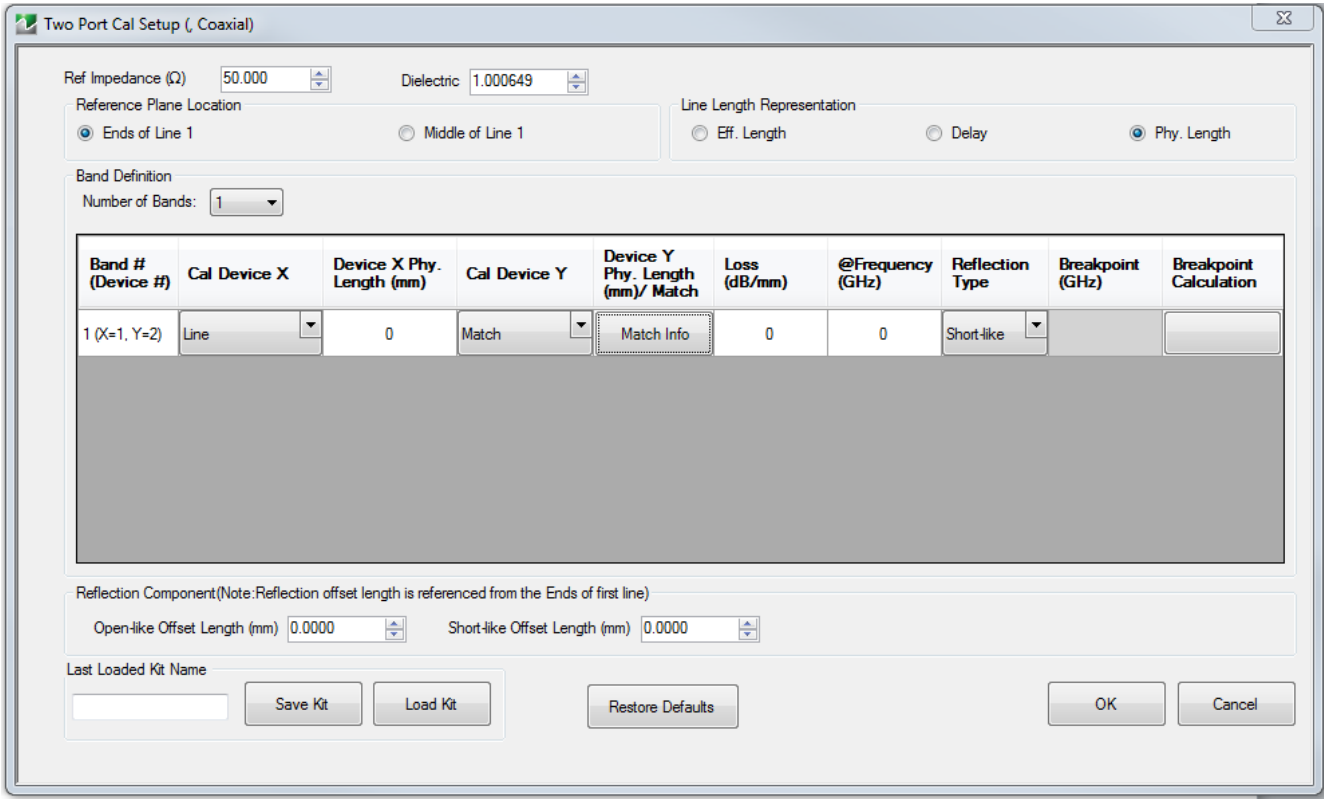

Typical parameters - One Band LRM Using Two Reflects

Figure 6-4. TWO PORT CAL SETUP (LRL/LRM, COAXIAL) Dialog Box

Reflection Offset Length and Reflection Type

Some information is requested about the reflection although a full characterization is not needed. The information is used in some root-choice activities and it only needs to be known if the reflect behaves more like an open or a short (since typically opens and shorts are used as the reflect standard). The offset length is used to dynamically move the reference planes around so the algorithm will know what the reflect looks like at any given frequency.

6-3 LRL/LRM Calibration Step-by-Step Example

The following example presumes a MS46122A/B and MS46322A/B ShockLine VNA are on a coaxial setup. On-wafer scenarios can be accommodated by modifying the entries in [Step 4](#) below. It is assumed that a mating reference plane pair can be created (either MF in coax or zero length-thru compatible). In this example, a full 2-Port LRM calibration is performed, although a number of other options are discussed along the way. The implications of these options are further explained in the calibration overview section.

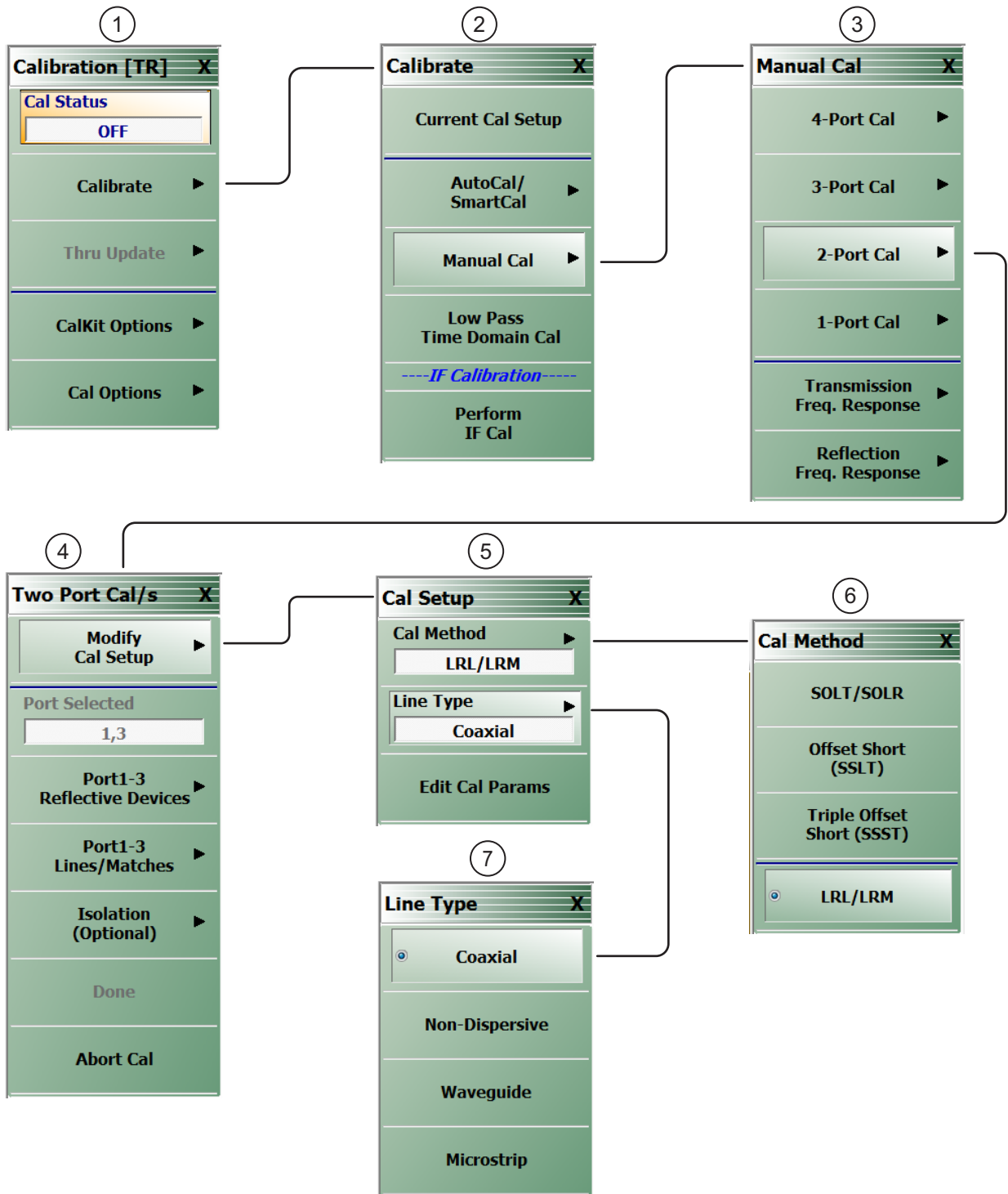

Figure 6-5. Calibration Menu Set for LRL/LRM Coaxial (1 of 2)

1. CALIBRATION menu	5. CAL SETUP menu
2. CALIBRATE menu	6. CAL METHOD menu
3. MANUAL CAL menu	7. LINE TYPE menu
4. TWO PORT CAL menu	

Figure 6-5. Calibration Menu Set for LRL/LRM Coaxial (2 of 2)

Procedure

The same menu structure appears for Tab A and Tab B. [Figure 6-6](#)

1. Setup the desired frequency range (**FREQUENCY** menu), power (**POWER** menu) and IFBW/averaging (**AVERAGING** menu). As a default, the IFBW will be 1 kHz and the averaging will be off which is adequate for many applications. The default power level will vary depending on instrument model and options but will often be adequate for all passive and many active device measurements
2. Navigate to the TWO PORT CAL menu.
 - MAIN | Calibration | CALIBRATION | Calibrate | CALIBRATE | Manual Cal | MANUAL CAL | 2 -Port Cal | TWO PORT CAL

Note If a previous cal exists, the Thru Update button will be active. See for more information "[Through \(Thru\) Update](#)" on page 8-1.

3. Select Modify Cal Setup and on the CAL SETUP menu, select a Cal Method of LRL/LRM and a line type of Coaxial.
4. Select Edit Cal Params to open the TWO PORT CAL SETUP (LRL/LRM, COAXIAL) calibration components dialog box.

Two Port Cal Setup (. Coaxial)

Ref Impedance (Ω) 50.000 Dielectric 1.000649

Reference Plane Location
 Ends of Line 1 Middle of Line 1
 Line Length Representation
 Eff. Length Delay Phy. Length

Band Definition
 Number of Bands: 1

Band # (Device #)	Cal Device X	Device X Phy. Length (mm)	Cal Device Y	Device Y Phy. Length (mm)/ Match	Loss (dB/mm)	@Frequency (GHz)	Reflection Type	Breakpoint (GHz)	Breakpoint Calculation
1 (X=1, Y=2)	Line	0	Match	Match Info	0	0	Short-like		

Reflection Component (Note: Reflection offset length is referenced from the Ends of first line)
 Open-like Offset Length (mm) 0.0000 Short-like Offset Length (mm) 0.0000

Last Loaded Kit Name
 Save Kit Load Kit Restore Defaults OK Cancel

Figure 6-6. Calibration Setup Dialog - TWO PORT CAL SETUP (LRL/LRM, COAXIAL) Dialog Box

5. On the TWO PORT CAL SETUP (LRL/LRM, COAXIAL) dialog box, set the following:
 - a. The Reference Impedance establishes the impedance for the load definition, reference plane changes and Smith chart plotting. The default is 50 ohms.
 - b. Select Ends Of Line 1 as the Reference Plane Location. Since this example uses a zero length line, the choice makes no difference.
 - c. For Number of Bands, select 1. For an LRL calibration, instead of LRM as in this example, the bandwidth of the calibration will be limited by the difference in lengths between the lines. Two bands can be used (with 3 or 4 lines) to cover a larger bandwidth.
 - d. For this example, set Band 1 Device 1 to Line with a Line Length of 0 and Line Loss of 0 dB/mm. The reference frequency for the loss can be entered as 0. In general, this forces no loss scaling with frequency and the line loss value entered will be used at all frequencies.
 - e. Set Band 1 Device 2 to Match since we are performing an LRM calibration. A specific match (or load) model may be entered under Match Info, but this example uses the default of 50 ohms.
 - f. For the Type of Reflection select Use Short-like Component. This implies the impedance is usually less than the reference impedance but it need not be precise. This information is used to help in root selection. Enter the Short-like Offset Length in the Reflection Component section at the bottom of the dialog box.
 - g. Click OK to accept the entries and close the dialog box. Select Back at the bottom of the Cal Setup menu to return to the previous level TWO PORT CAL menu.
6. The menu-by-menu procedure is shown in the figure below.

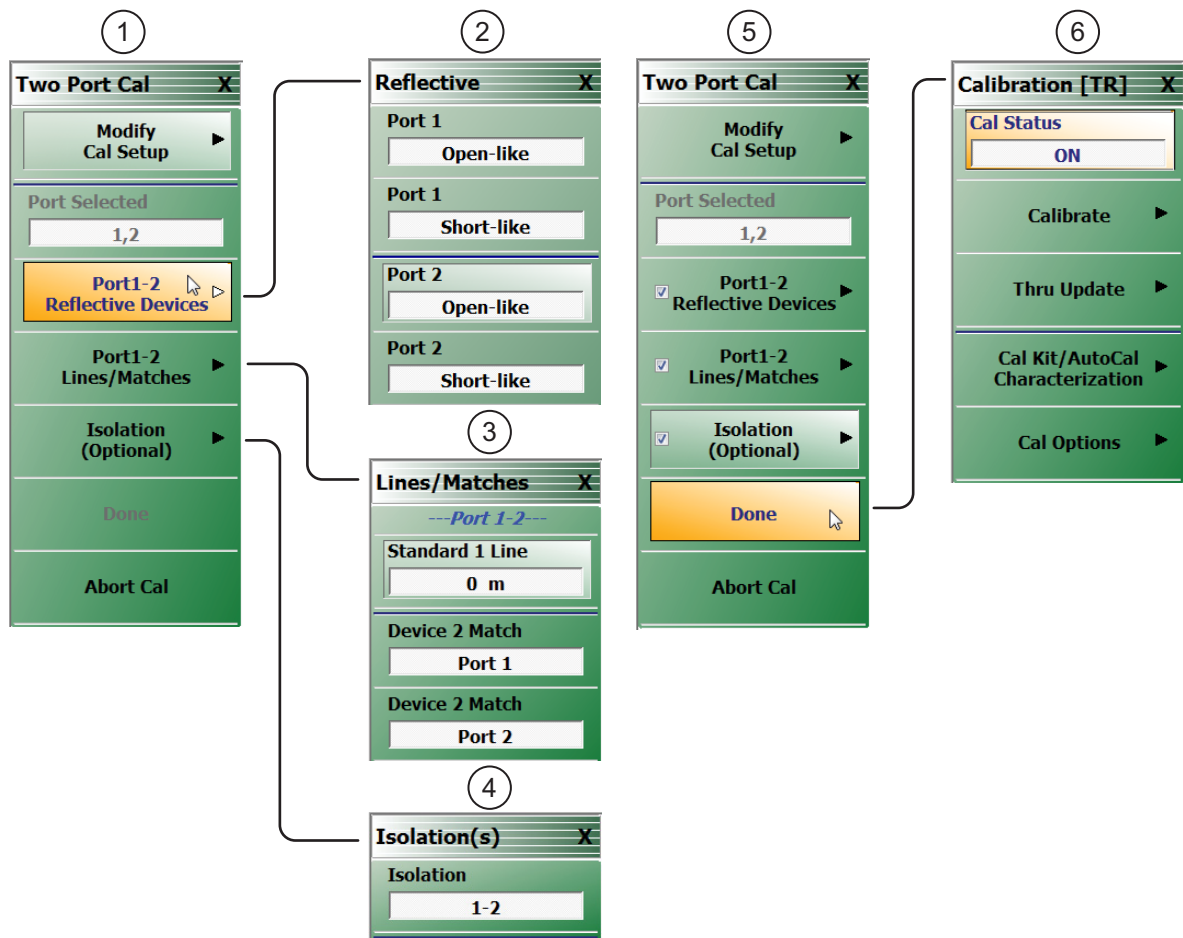

Figure 6-7. Two Port LRL/LRM Coaxial Calibration Procedure Menus (1 of 2)

1. The TWO PORT CAL menu with link/completion buttons for Port 1-2 Reflective Devices, Port 1-2 Lines/Matches, and Isolation (Optional).	4. Optional ISOLATION Port 1-2 Menu
2. REFLECTIVE Port 1-2 Menu	5. TWO PORT CAL menu after all calibration procedures successfully completed. Note Done button is available.
3. LINES/MATCHES Menu	6. CALIBRATION Menu with Cal Status set to ON.

Figure 6-7. Two Port LRL/LRM Coaxial Calibration Procedure Menus (2 of 2)

7. On the TWO PORT CAL menu (above in [Figure 6-7 – #1](#)), select the Port 1-2 Reflective Devices button and its linked REFLECTIVE menu ([Figure 6-7 – #2](#)). In this example, the short-like reflective device must be measured at both ports. After the device is connected to a given port, click the corresponding button (a check mark will then appear after the measurement). Click on Back when done with this step to return to the TWO PORT CAL menu.
8. Connect the reference planes together to form the 0 (zero) length line. Select Port 1-2 Lines/Matches and on the LINES/MATCHES menu ([Figure 6-7 – #3](#)), click on Device 1 Line (0m). Sequentially connect the load (or loads if two models were entered for two physically separate loads) and click the corresponding buttons. For this example, repeat for **Device 2 Match at Port 1** and then **Device 2 Match at Port 2**. As before, check marks will appear when a given step is completed. Click Back when completed and then Done.
9. An optional isolation step using the Isolation (Optional) button and the linked ISOLATIONS menu (above [Figure 6-7 – #4](#)) is available but is generally not recommended. If desired, terminate **Port 1** and the end of the cable attached to **Port 2** before clicking on the Isolation 1-2 button.
10. When all procedures are complete (at [Figure 6-7 – #5](#)), the Done button on the TWO PORT CAL menu is available. Click on Done. The focus returns to the CALIBRATION menu (at [Figure 6-7 – #6](#)) where the Cal Status button is set to ON.

6-4 Hints and Suggestions

Since there are a number of choices involved in setting up the LRL/LRM family of calibrations, some additional hints and points of emphasis may be of assistance:

- Reflect offset lengths are referenced to the ends of Line 1. These lengths are all air-equivalent lengths. The line length entries for the transmission lines are also air-equivalent. If the lengths are known in terms of time delay, the air-equivalent length is given by:

$$\text{time delay (seconds)} \times 2.9978 \times 10^8 \text{ (m/s)}$$
- The frequency breakpoint for 2-band calibrations is calculated from the geometric mean of the theoretical upper limit of the low band and the theoretical lower limit of the upper band. The former is calculated based on the 160 degree delta frequency and the latter is calculated from the 10 degree delta frequency. This decision is somewhat arbitrary and is heavily dependent on the materials involved and uncertainties required. With relatively lossy lines, one can approach the limits more closely than with low-loss lines. The impact is also dependent on transmission line quality. If both lines have an impedance of, for example, 50.1 ohms and one measured a theoretical -80 dB termination, the result would be predictable limited by the line impedance imperfection to about -61 dB at all frequencies. If instead, one line was 50.1 ohms and one was 50.2 ohms, then one gets progressively more effect near the theoretical edge frequencies as shown in the figure below.

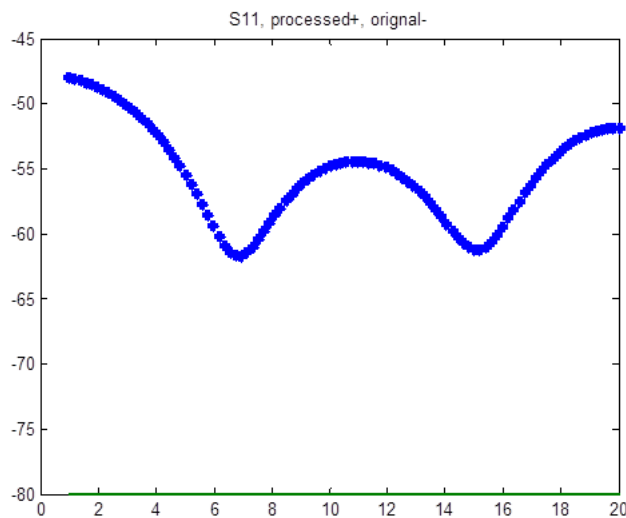

Figure 6-8. The effect of line impedance problems gets magnified as the line length delta approaches the theoretical band edges (the result for a high RL termination measurement when calibrated with unequal line impedances). This should be considered when deciding on the 2-band breakpoint frequency.

- When doing two band TRL/LRL calibrations, the orientation of the lines between bands can sometimes be confusing. The larger line delta should always be in band 1 (the lower frequency section).
- The TRL family of calibrations is more sensitive to asymmetries in standards (for example: different reflects on the two ports, lines of different impedance) than to problems in the standards themselves. When creating a custom calibration kit, this can be an important point. As an example, the effect on the measurement of a mismatched delay line is shown in [Figure 6-9](#) when there was a global 10 % impedance error on the LRL calibration lines and when the error was on only one line.

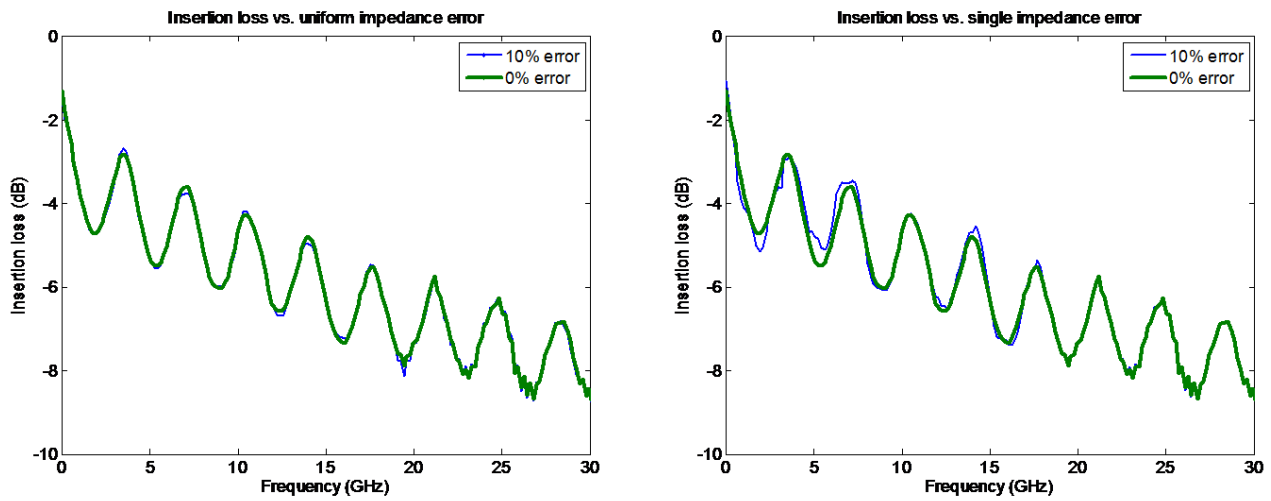

Figure 6-9. TRL/LRL is more sensitive to differences between the line impedances than to the absolute line impedance (although problems on that will shift the reference impedance of the calibration).

Chapter 7 — Adapter Removal Calibrations and Network Extraction

7-1 Introduction

This chapter describes various methods for handling cases of non-insertable DUTs. In some coaxial cases, this can be handled with a special class of adapter removal calibrations. More generally, de-embedding can be used to remove the effects of fixtures or adapters required to execute the measurement. The de-embedding process itself will be covered in a later chapter, but the means of evaluating the network to be de-embedded will be addressed here.

While it is usually desired to perform a 2-Port calibration with mating connectors of the same type, this is sometimes not possible based on the connectors of the device to be tested. Examples of this include:

- The DUT has one N port and one GPC-3.5 port
- The DUT has two female SMA ports and it is not desired to use a non-zero length thru
- The DUT has one fixtured port and one SMA port
- The DUT has one waveguide port and one coaxial port

What these examples share is that completing the through line between the effective test ports requires some kind of adapter or fixture. Since the adapter has some phase length, loss, and mismatch, its effects should be removed for a high quality calibration. Adapter removal is a utility to characterize this adapter and remove its effects from a calibration.

In the more general case of de-embedding, a means of determining the network to be de-embedded must be available. Techniques similar to adapter removal, that is a measurement using one or more calibrations, can be used to extract these parameters. As such network extraction can be viewed as a generalization of adapter removal.

7-2 Two Related Sets of Reference Planes

The concept of the adapter removal relies on the existence of two related sets of reference planes with one set on either side of the adapter (see [Figure 7-1](#)). Assuming one can perform a full calibration at each set of reference planes, there is enough information to extract the behavior of the adapter itself. When the calibration is being performed at the reference planes on the left (between Ports 1 and 2'), the adapter behavior is embedded in the characteristics of Port 2'.

Similarly, when the calibration is being performed between Ports 1' and 2, the adapter behavior is embedded in that of Port 1'. Since each of these two calibrations involve mating connector types, these are far easier to perform than the direct 1-2 calibration. It will not be shown here, but the use of the two calibrations provide nearly enough information to extract the parameters of the adapter itself. Figure 7-1 shows the structure of the adapter removal calibration. Two calibrations are performed at the two sets of reference planes shown (between Ports 1 and 2', and between 1' and 2), which allows a determination of the adapter behavior. After the adapter removal, the resulting calibration will be between Ports 1 and 2.

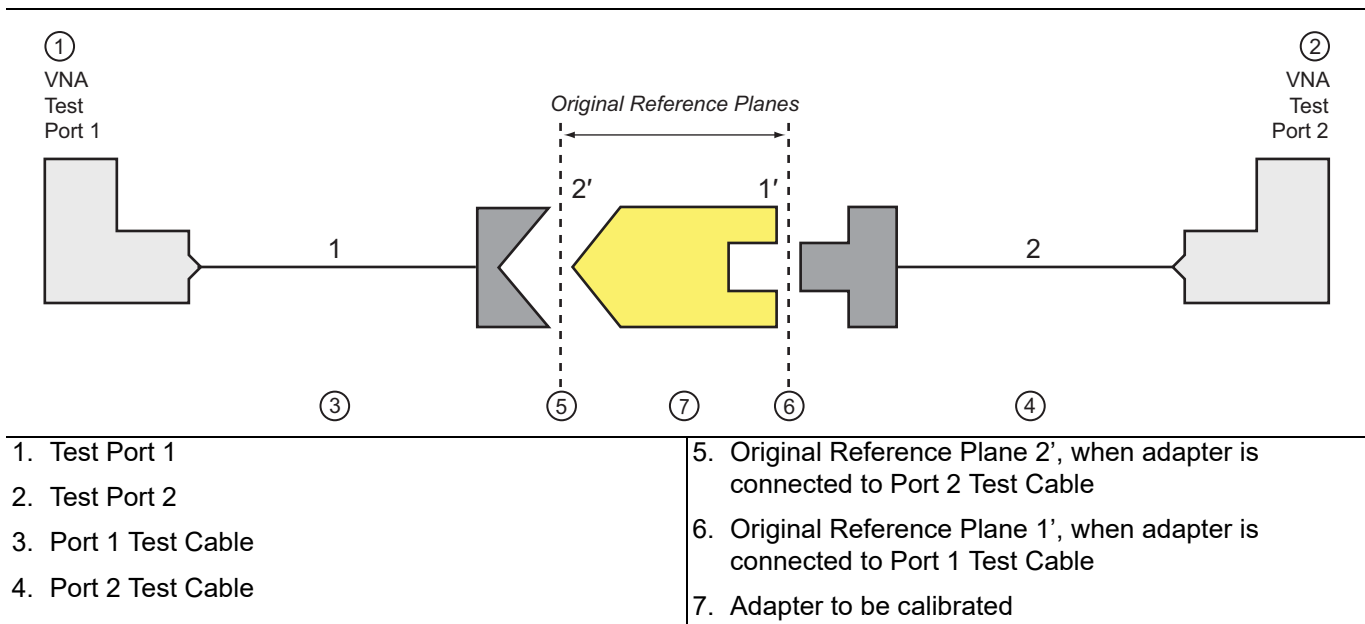

Figure 7-1. Adapter Removal Block Diagram

Caveats and Limitations

There are two caveats to this procedure.

First, only the $S_{12}S_{21}$ products of the adapter can be determined from this procedure, not the two transmission terms individually. However, since only the product is needed to de-embed the adapter effects, this is not much of a problem. Most adapters are passive and reciprocal anyway, so the individual terms could be determined if necessary.

Second, there is a complex square root operation involved, so a root determination is necessary. To help this, the user must enter a guess as to the electrical length of the adapter (in ps of delay). The guess need not be very accurate, just within the correct half plane. At 2 GHz, this means the error in delay entry should be less than 125 ps to ensure the correct root is selected.

In general the error must be less than $\frac{1}{(4f)}$ where f is the highest frequency being used.

One can enter 0 for the length estimate to force the software to do length estimation internally. This calculation is based on the phase change between frequency points towards the lower end of the sweep range. A linear fit to the phase function is performed and the slope is used to estimate the electrical length as suggested by Figure 7-2. This procedure is quite accurate unless the frequency step size is large relative to the phase change in the measurement. Thus, if the setup uses very long cables, it may help to increase the number of frequency points or at least look at a raw S_{21} phase display (no calibration applied with something of modest insertion loss connected) and see how often the phase wraps.

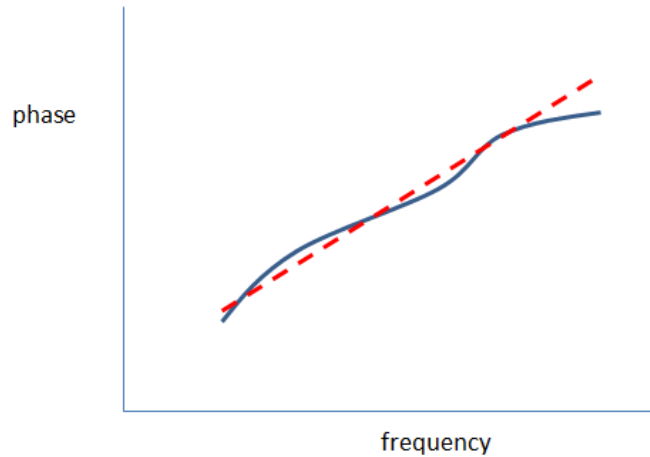

Figure 7-2. By entering 0 as the length estimate, the software calculates a length estimate for you. If the frequency step size is large relative to the electrical length of the setup, this may not be advisable.

In the first plot of Figure 7-3, one can see how the first frequency step size would be adequate for this setup. The phase change between points is well below 180 degrees so linear fitting will not run into aliasing problems. In the second setup (next page), the phase change between points is nearly 360 degrees so one may start to run into aliasing issues with the 0-entry-length-estimation. For this case, the point count should be increased at least somewhat or a manual length entry can still be used in Adapter Removal.

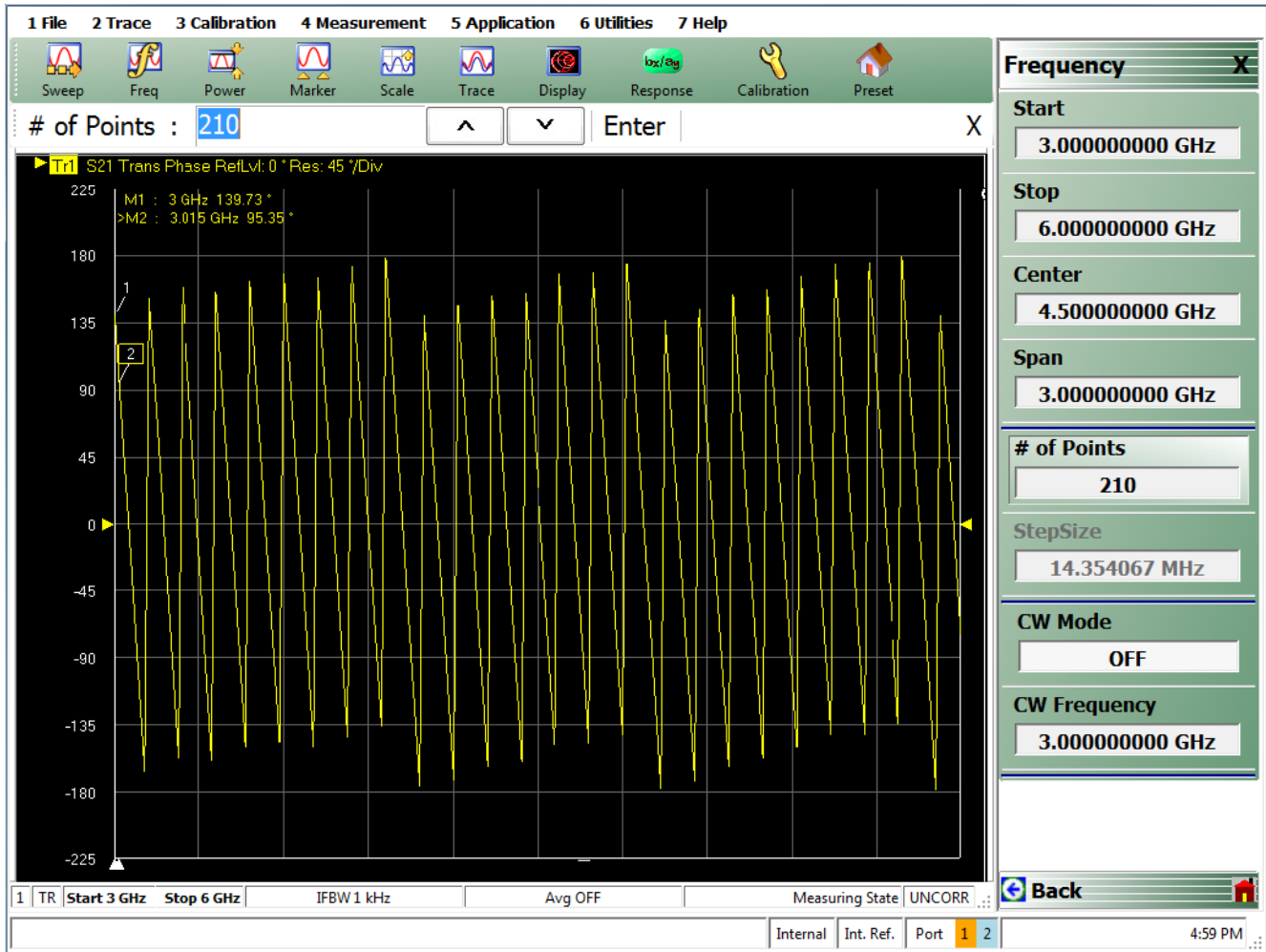

Figure 7-3. Uncalibrated phase plots from an example setup for two different step sizes

In the second case, the automatic length estimation may run into aliasing problems if much more length is added. (1 of 2)

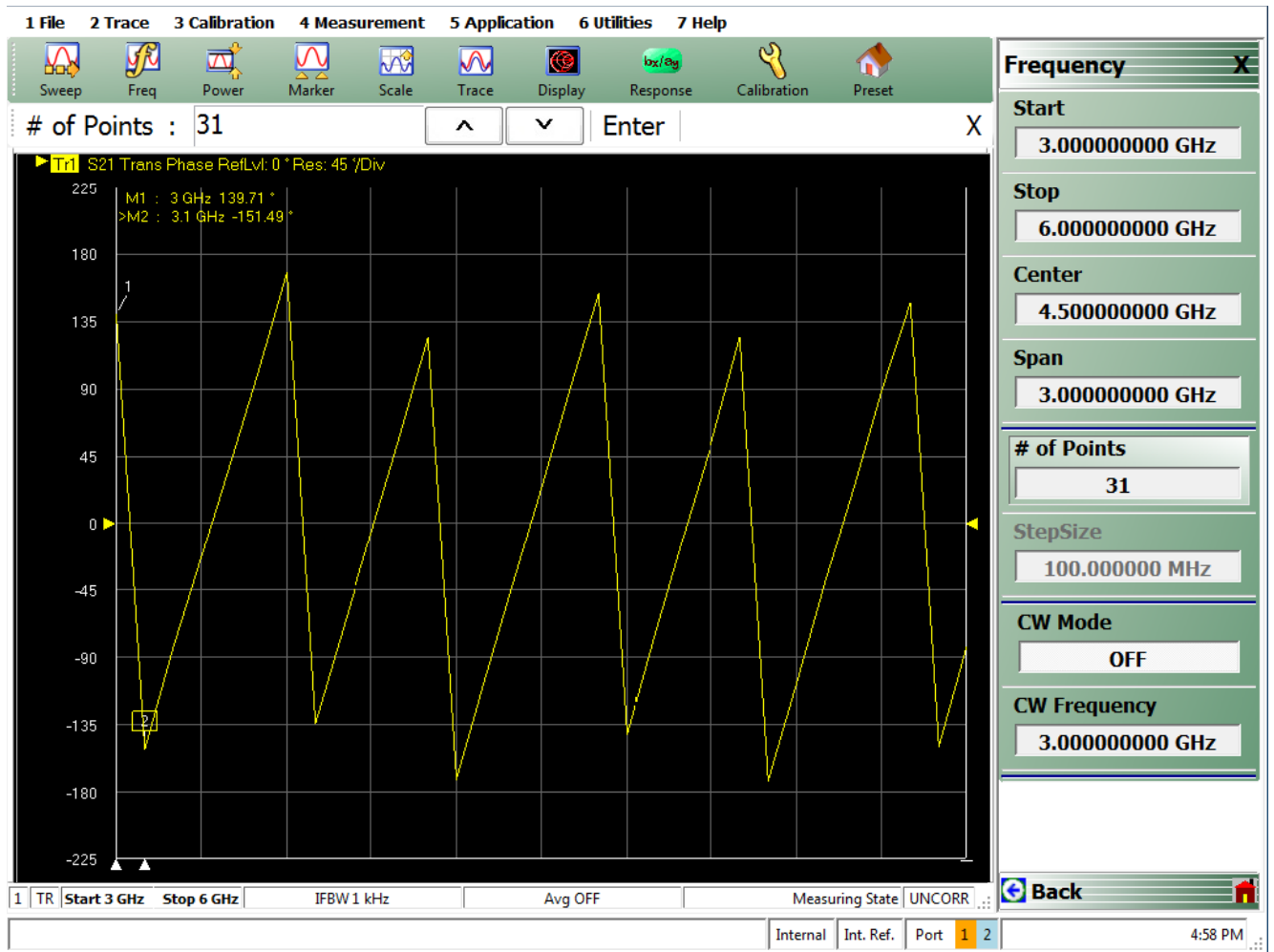

Figure 7-3. Uncalibrated phase plots from an example setup for two different step sizes

In the second case, the automatic length estimation may run into aliasing problems if much more length is added. (2 of 2)

7-3 Performing an Adapter Removal

Two full 2-Port calibrations must be performed and those calibrations (plus front panel setups) must be stored to the current directory on a USB memory device or hard disk. The setups for the two calibrations should be the same in terms of frequency range and number of points. Upon entering the adapter removal utility, an estimate for the electrical length of the adapter must be entered as well as the location of the two calibrations. Once this is done, the utility will generate and apply a new calibration by removing the adapter effects. The menu and help screen for this procedure are shown in [Figure 7-4](#).

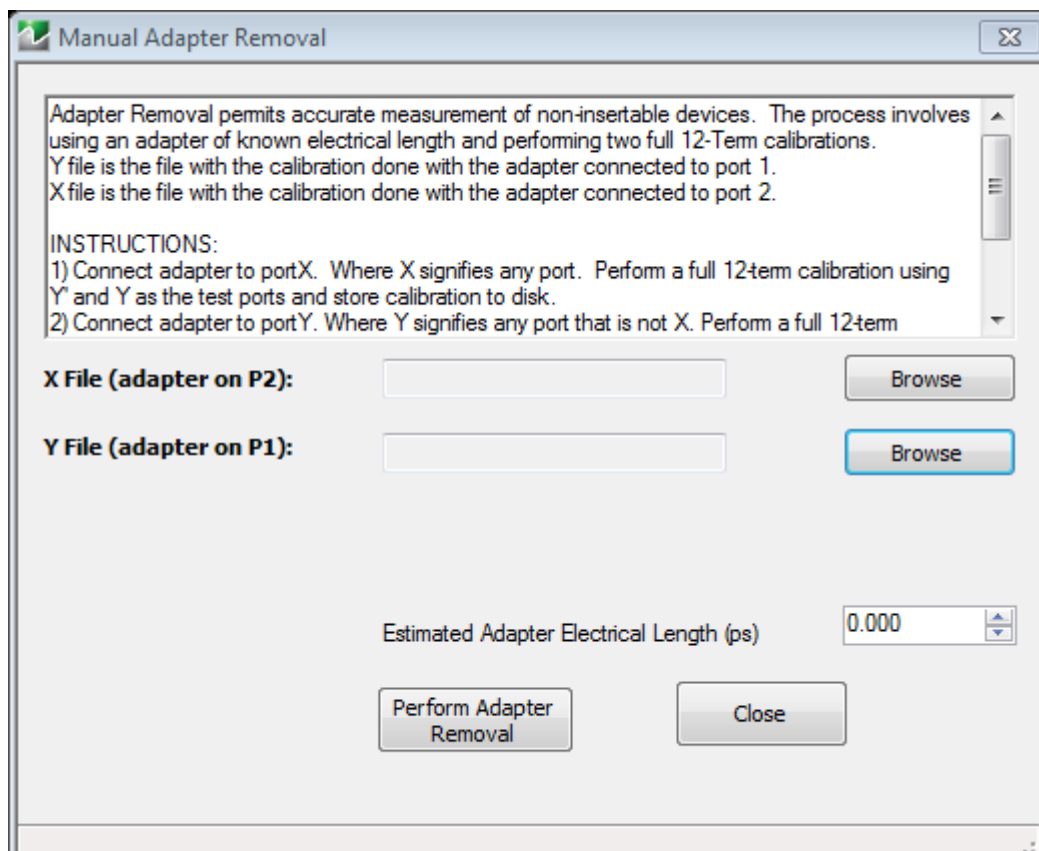

Figure 7-4. MANUAL ADAPTER REMOVAL Dialog Box - 2-Port VNAs

Example Adapter Removal

The following example should help illustrate the use of the adapter removal utility. An adapter was constructed with about 3 dB of loss and 180 degrees of phase shift at 3 GHz. This leads to an estimate of the delay length of:

$$\phi = \omega\tau \quad \tau = \frac{\theta}{\omega} = \frac{\pi}{2\pi(3 \times 10^9)} \approx 167\text{ps}$$

Equation 7-1

Since the loss of this adapter is substantial, one could not simply use reference plane extensions to remove the phase shift and hope for an accurate result.

The two calibrations described earlier were performed and stored to the hard disk and the adapter removal was executed. A through was then connected without the adapter in place. Normally this would not be possible (since the whole reason for using the adapter removal was for situations when a thru would be difficult), but this example adapter was constructed just to show that the algorithm functions correctly. The results are shown in [Figure 7-5](#).

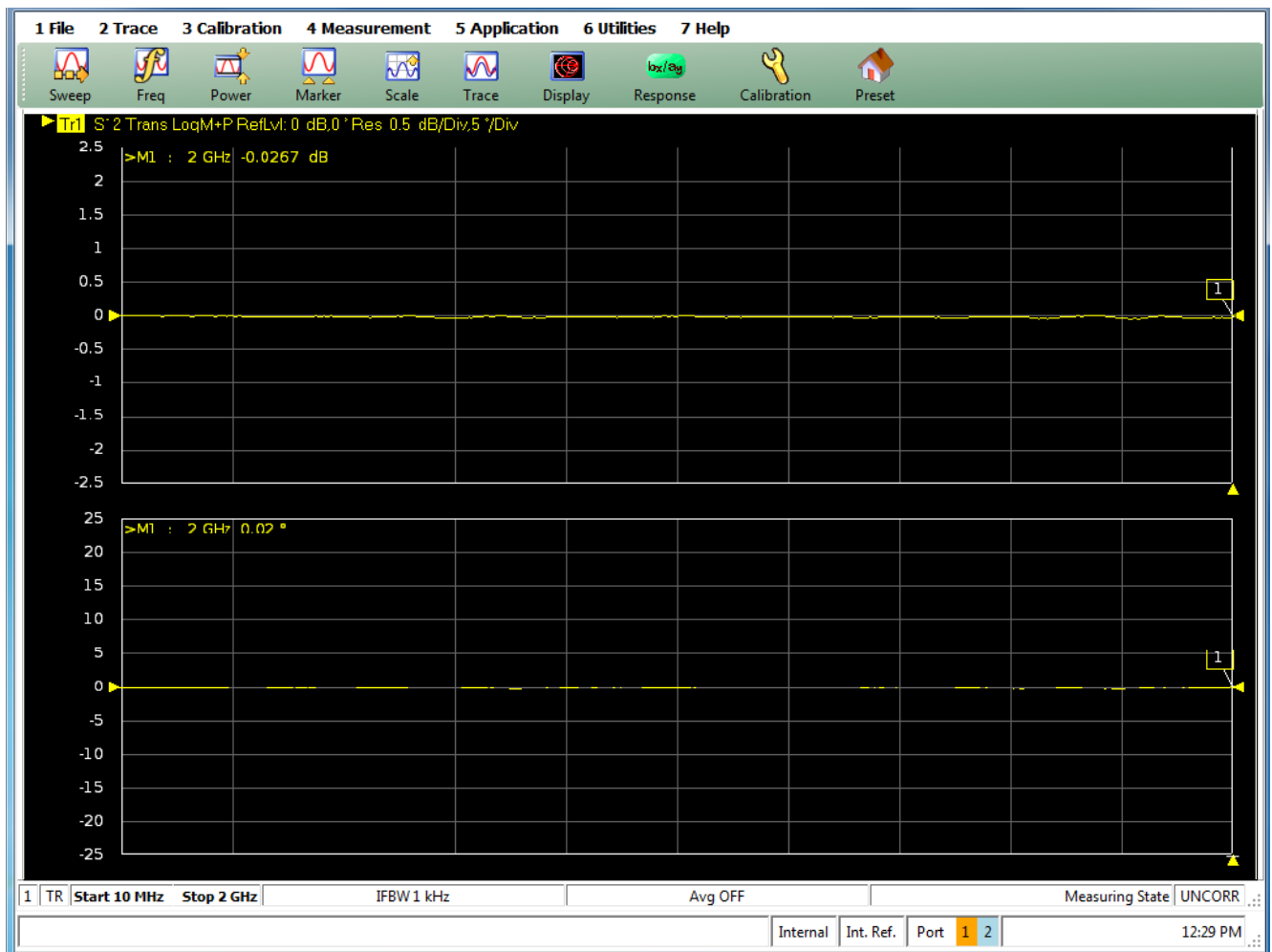

Figure 7-5. VNA Trace Display with Result of Adapter Removal

The through without the adapter was connected after executing the adapter removal utility and the near-perfect through values for S_{21} show that the algorithm successfully removed the adapter from the calibration. As expected, the thru without the adapter shows nearly zero insertion loss and phase shift, and a very good match. Any residuals are largely due to cable flex. Had this connection been made with one of the initial two calibrations applied, S_{21} would have shown about 3 dB of gain since the adapter had been built into each calibration.

7-4 Network Extraction

Overview

De-embedding is covered in detail in [Chapter 9, “Calibration and Measurement Enhancements”](#) but since the generation of files for some de-embedding exercises is so closely tied to adapter removal; it will be briefly discussed now. De-embedding is the removal of the effects of a network from a set of data. This network could represent an adapter or fixture, among other things. To perform the de-embedding, the parameters of this network must be known. While there are many methods of deriving these parameters (including simulation), measurement in some way is often preferred. Because of the complex and incompatible media that may be involved, techniques using multiple calibrations (in different connectors or different media) or techniques using a pair of adapters/fixtures back-to-back are sometimes employed.

For the 2-port VNA without Option 24, there are **four** types of extraction techniques available, as shown in the dialog in [Figure 7-6](#).

For the 2-port VNA, when Option 24, Universal Fixture Extraction, is added, there are **six** types of extraction techniques available, as shown in the dialog in [Figure 7-7](#).

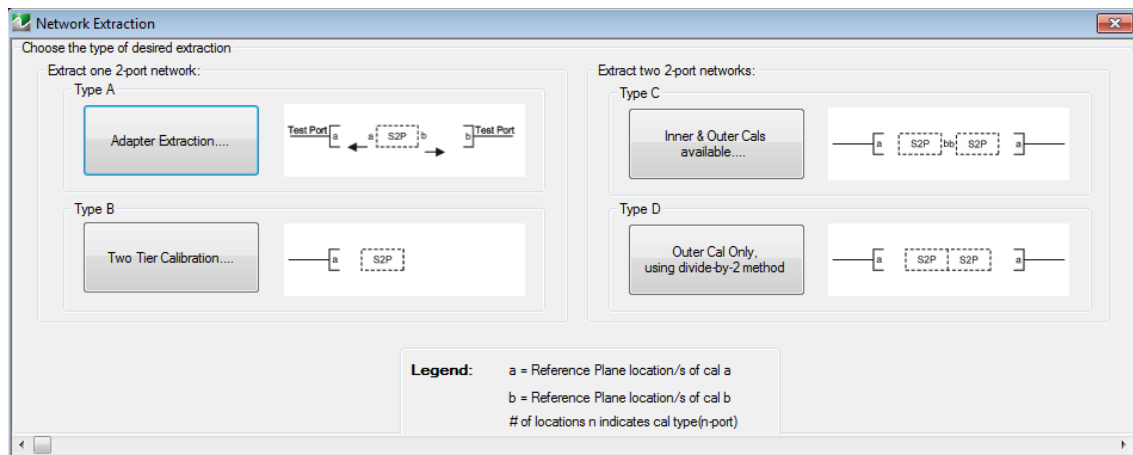

Figure 7-6. NETWORK EXTRACTION Dialog Box—2-Port VNAs

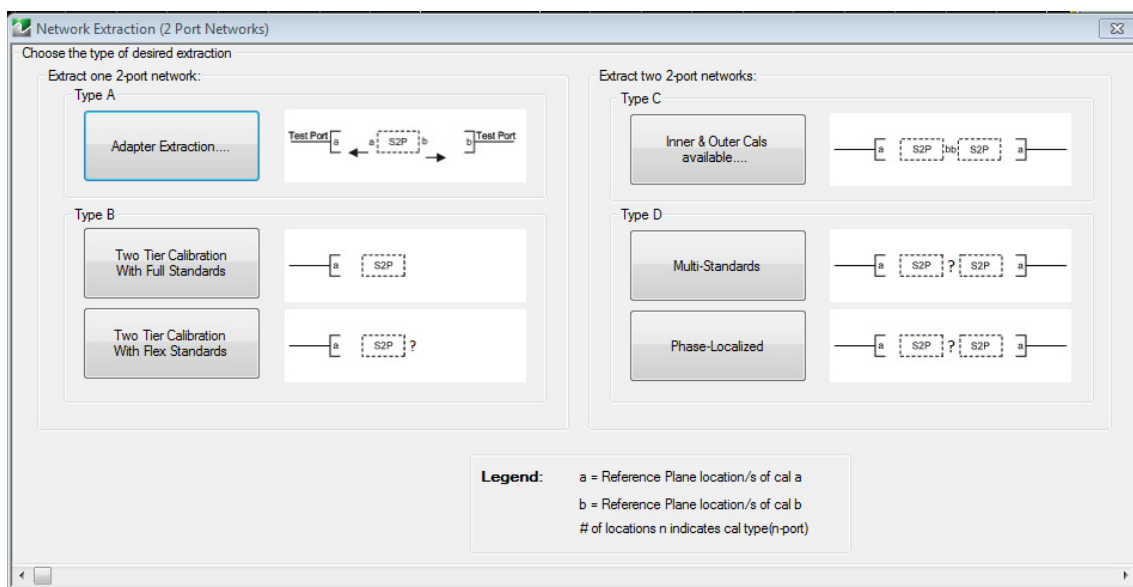

Figure 7-7. NETWORK EXTRACTION Dialog Box—2-Port VNAs (Option 24 Enabled)

Type A—Adapter Extraction

Two full 2-Port calibrations are performed; one each with the adapter/fixture attached to one port, then the other. A single S2P file describing the adapter/fixture is generated. This is directly the method of adapter removal except the parameter file is generated explicitly rather than the calibration being directly modified. Refer to [“Type A Network Extraction”](#).

Type B—Two Tier Calibration With Full Standards

A two tier calibration, sometimes called 1-Port de-embedding or the Bauer-Penfield technique. Here a one port cal is performed, and then additional standards are measured with the adapter/fixture in place. A thru connection is not required, which can be convenient in many cases, and a single .s2p file is generated. In the full standards case (an entire second calibration is required at the end of the adapter/fixture), the calculation is similar to Type A, except the outer match is handled differently. Refer to [“Type B Network Extraction”](#).

Type B—Two Tier Calibration With Flex Standards

Algorithmically, this is similar to the full standards case, but a different, or incomplete, calibration may be performed at the fixture output plane. Additional assumptions are made as the standards count dropped (e.g., with one standard, fixture match is neglected).

Type C—Inner and Outer Cals Available

This is the network extraction method available in earlier generations of Anritsu VNAs where full 2-port calibrations are performed at the outer plane (often coaxial or waveguide) and at the inner plane (often a fixtured environment). Two S2P files are generated in this case. Refer to [“Type C Network Extraction”](#).

Type D—Outer Cals Using the Divide-By-Two Method (Multi-Standards)

This simplified method is used when standards at the inner plane are difficult to create (as in a complicated fixture structure). Two adapter/fixture “halves” are connected back-to-back and/or with some standards between them and the combination measured using a single outer cal. Assuming the interconnect between the two halves is well-matched and the two halves are identical, S-parameters can be extracted. At least one thru interconnect between halves is needed and an additional (different length) interconnect can be used or high reflection standards can be used at the inner plane. If only one interconnect is used, inner plane match is assumed perfect. Additional information is obtained and accuracy generally improves as more standards are added. Two S2P files are generated. Refer to [“Type D Network Extraction—Multi Standards \(with Option 24\)”](#).

Type D—Phase Localized

A variation of type D makes use of knowledge of fixture length (through user entry or model fitting) to better localize mismatch and enable a more accurate extraction if the fixture is electrically long enough. Refer to [“Type D Network Extraction—Phase Localized \(with Option 24\)”](#).

7-5 Type A Network Extraction

As discussed earlier, the Type A extraction uses exactly the same procedure and algorithm as adapter removal. Instead of directly modifying the calibration to remove the effects of the adapter/fixture, however, the S-parameters of the adapter/fixture are exported to an S2P file for later de-embedding or other uses. The reference plane diagram is repeated in Figure 7-8 for convenience. Two full 2-Port calibrations are required, one with the adapter on **Port 1** (so the cal is between 1' and 2) and one with the adapter on **Port 2** (so the cal is between 1 and 2').

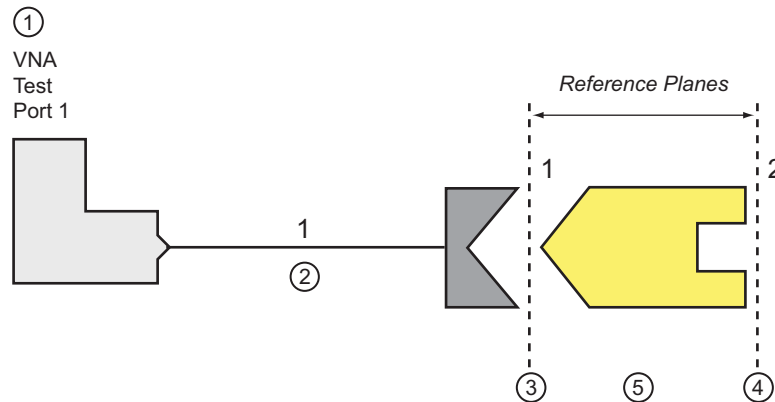

1. Test Port 1	5. Original Reference Plane 2', when adapter is connected to Port 2 Test Cable
2. Test Port 2	6. Original Reference Plane 1', when adapter is connected to Port 1 Test Cable
3. Port 1 Test Cable	7. Adapter to be calibrated
4. Port 2 Test Cable	

Figure 7-8. Adapter Removal Block Diagram

The calibrations are performed and then the setups saved typically as an active channel CHX file type. The extraction dialog is shown in Figure 7-9, where these files are retrieved to perform the process. After Perform Extraction is selected, a new dialog will appear asking for the file name where the S2P data should be saved.

As with adapter removal, a few caveats apply:

- The two calibration files must have the same frequency lists (i.e., same frequency range and same number of points).
- The cal algorithms and media types may be different but they must both be full 2-Port cals
- The adapter is assumed to be reciprocal ($S_{12} = S_{21}$).

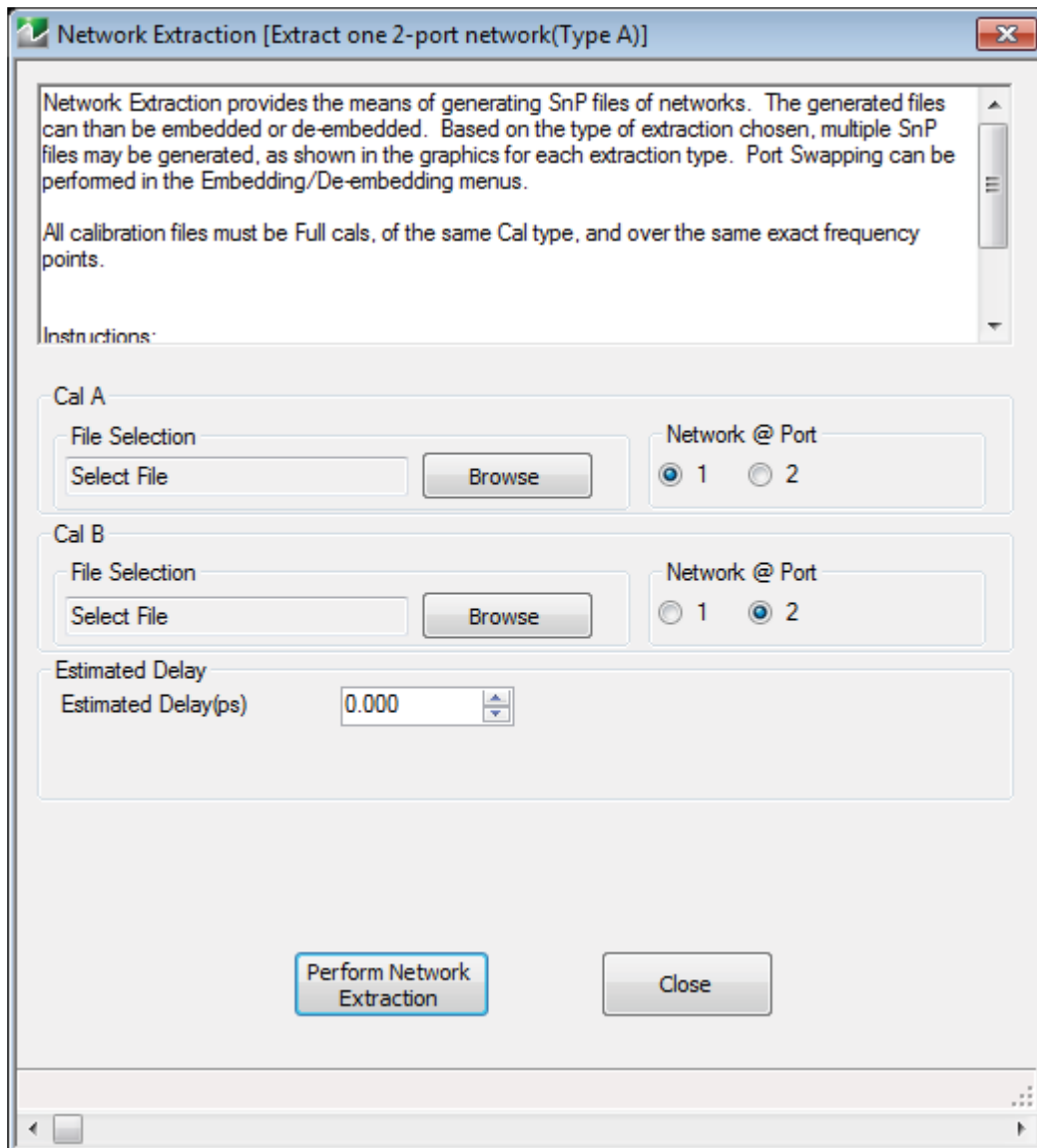

Figure 7-9. NETWORK EXTRACTION Dialog Box—Extract One 2-Port Network—Type A—2-Port VNAs

7-6 Type B Network Extraction

The Type B extraction is a simplification of Type A in that it only requires one-port standards. There are two variations of Type B: full standards and flex standards. Both variants can be useful if a thru connect is difficult to implement because of adapter/fixture configuration issues. The two versions are:

Full Standards: Requires three reflect standards (a full one-port calibration) at the far end of the fixture arm. This completely solves the reciprocal error box describing the fixture but does require three known standards.

Flex Standards: This allows 1, 2 or 3 reflection standards to be used at the far end of the fixture arm for cases when a variety of different standards may be available. The three-standard case is simply a generalization of the ‘full calibration’ case where a variety of different standards can be easily tried if independent (e.g., 2 offset opens and a load, 2 offset shorts and an offset open, etc.). The one and two standards cases make assumptions about the fixture (partial information techniques) for cases when few known standards are available. An additional option will be required (Option 24) for this choice to be available.

Type B Network Extraction—Full Standards

The full calibration algorithm has a long history and is covered in the literature extensively (for example, R. Bauer and P. Penfield, “De-embedding and unterminating,” *IEEE Trans. Micr. Theory Tech.*, vol. 22, pp.282-288, Mar. 1974.). As suggested by Figure 7-10, a calibration is performed at Plane 1 (often a coaxial or waveguide calibration) and a second calibration is performed at Plane 2 (could also be coaxial or waveguide in the case of an adapter or could be more complicated in the case of a fixture).

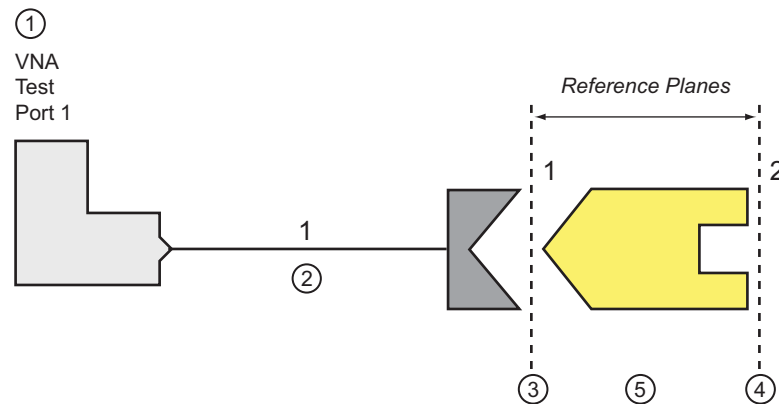

1. Test Port 1	4. Second Reference Plane at end of Adapter DUT
2. Port 1 Test Cable	5. Adapter DUT
3. Original Reference Plane for Port 1	

Figure 7-10. Network Extraction Type B Reference Planes

As before, the calcs are performed and the setups saved, typically as an active channel CHX file type. The cal files are retrieved using the dialog shown in [Figure 7-11](#).

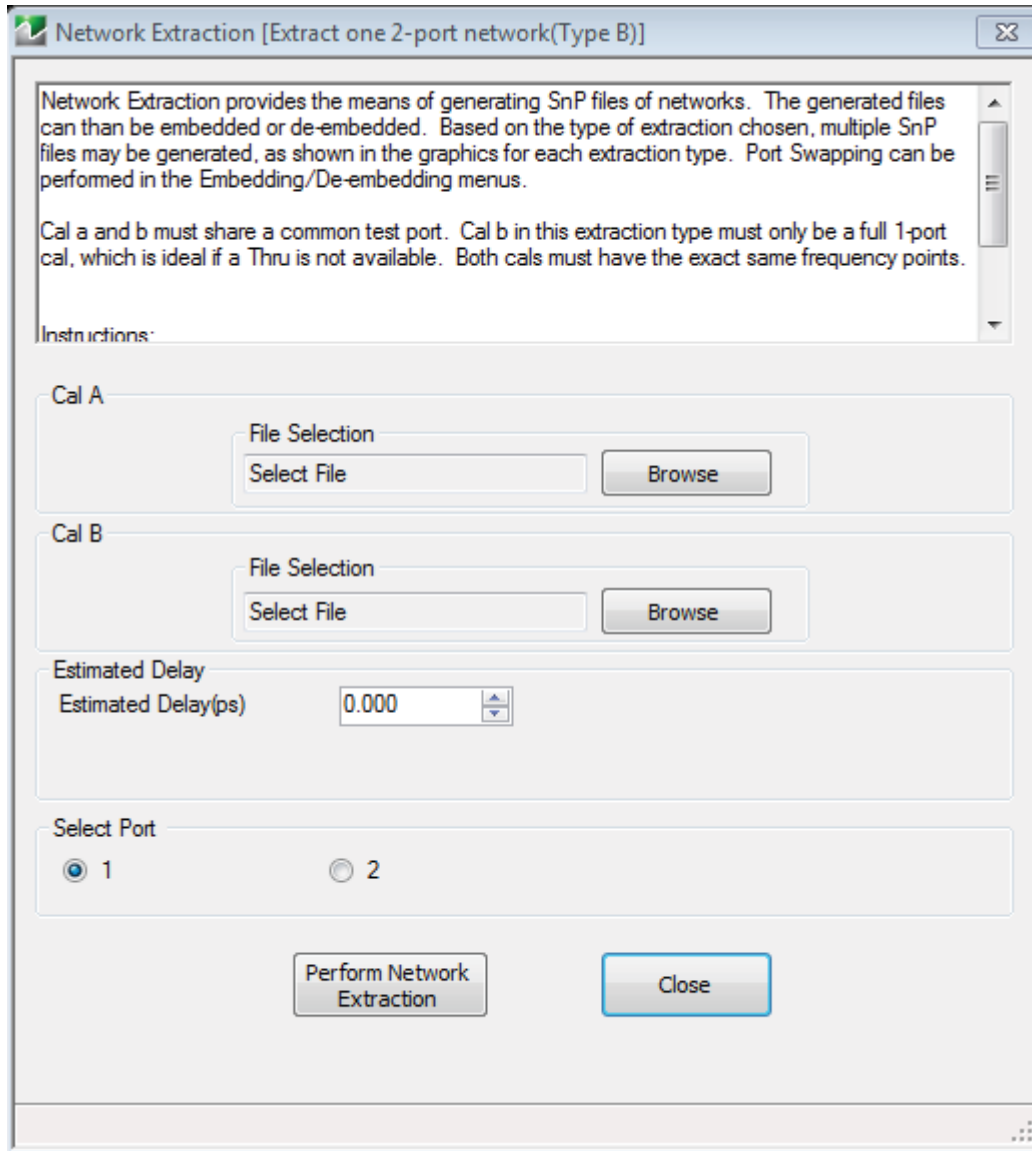

Figure 7-11. NETWORK EXTRACTION Dialog Box—Extract One 2-Port Network—Type B—With Full Standards

After Perform Network Extraction is selected, another dialog appears asking for the file name where the resulting S2P data should be saved. Different cal algorithms and media types may be selected but at least Cal B must be 1-Port only. Cal A can be a full 2-port cal or a double 1-Port cal (this way it is known how to compute the extraction). As with Type A, the adapter/fixture is assumed to be reciprocal and the frequency lists must be the same.

The results obtained with Type B may be somewhat different from those obtained with Type A since the algorithms are not the same. The main differences will be with respect to outboard match (at Plane 2 in [Figure 7-10](#)). In Type A, this match is determined with a full reflectometer solve while in Type B, it is determined with a source-match like extraction on the error X of the second cal. As a result, the Type B extraction of this match will be somewhat more sensitive to cal quality than will Type A (particularly with regard to the source match-determining cal components: O and S in OSL or the two shorts in SSL). The trade-off is simplicity and, in some cases, practicality.

Type B Network Extraction—Flex Standards (with Option 24)

There are a number of cases where it is not practical to perform a conventional one-port calibration at the far end of the fixture arm. An unusual set of three standards may be all that is available or only one or two reasonably-well-known standards exist. The ‘flex standards’ variant handles these cases. As with ‘full standards’ the user will select the port in question, an estimate of the length of the arm (and use 0 for an automatic estimate) and where to save the .s2p file for the fixture arm. Also as in the ‘full standards’ case, the fixture will be assumed to be reciprocal, but not necessarily symmetric. In this variant, the user must also select the number of standards as shown in Figure 7-12.

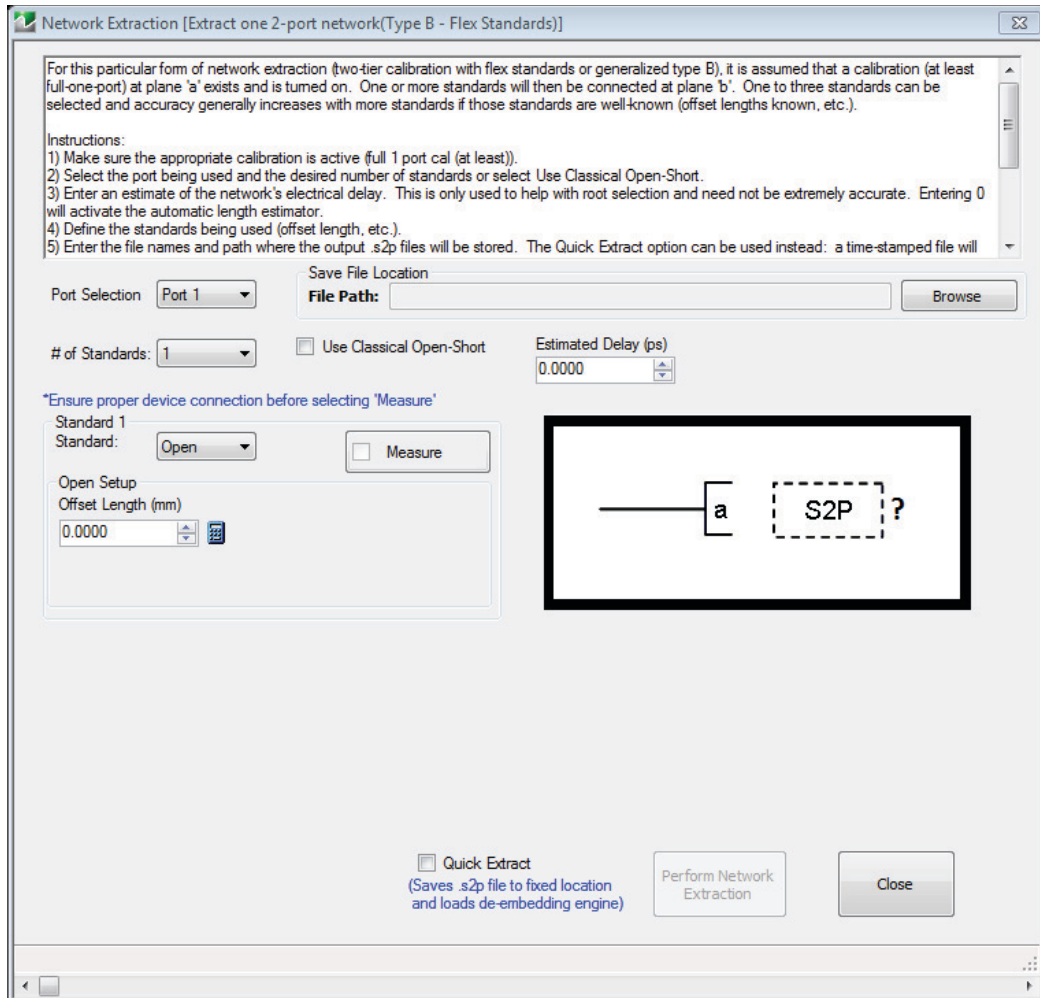

Figure 7-12. NETWORK EXTRACTION Dialog Box—Extract One 2-Port Network—Type B—Flex Standards Variant

When using one standard, only the insertion loss and phase of the fixture arm will be solved for and the match will be assumed to be perfect. If the fixture is well-matched anyway (e.g. the return loss is >15 dB and no deep return loss DUTs need to be measured), this can be a good choice. If only one defined standard is available (e.g., only an open-ended fixture is available), this may be the only choice. Obviously there will be some added uncertainty as fixture mismatch increases. Almost always a high-reflect standard (e.g., open or short) is used for this method.

When using two standards, the mismatch of the fixture arm is assumed to be symmetric but not perfect. If the fixture loss is low, this can be a reasonable approach and is particularly popular in on-wafer applications (also termed an open-short de-embedding method). Most commonly, two high reflect standards are used for this method but a higher return loss device can be substituted to tilt the uncertainty picture more in favor of low reflection DUTs.

The three standards case is very similar to the 'full standards' variant but allows additional flexibility on what those standards are. Examples could include multiple offset open standards used with shorts or loads, a variety of .s1p defined standards, etc.

Four types of standards are available:

Open: Defined only by an offset length relative to the desired reference plane. Loss of the open is not included.

Short: Defined only by an offset length relative to the desired reference plane. Loss of the short is not included.

Load: Defined by a resistance, an inductance and an offset length relative to the desired reference plane. The resistance and inductance are in series as shown in [Figure 7-13](#).

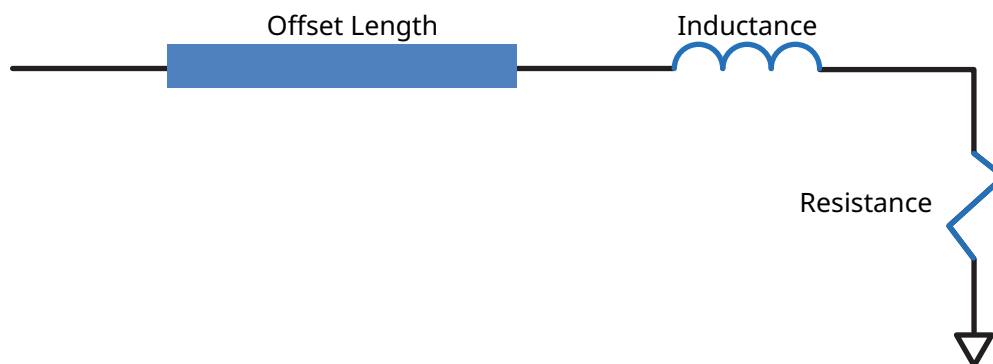

Figure 7-13. Flex Standards Load Model

.s1p-Defined: Defined by an S-parameter file for the standard supplied by the user. The values will be interpolated to match the current frequency list. If the file frequency list and the current list are incompatible (too small an amount of overlap), an error will be generated.

Considerable flexibility is given to the user on selecting the standards to employ but not all combinations will work. On 2 and 3 standards cases, the selections must produce different reflection coefficients at every frequency in the sweep range or singularities will occur. Checking is only done by the system to see if two identical standards are entered but even different entries can produce the same reflection coefficient. An example is a 2 standard, short open case where the short and open have different offset lengths. If, for example, the short offset length is 1mm and the open offset length is 2mm, the two standards produce the same reflection coefficient at 75 GHz. For lower frequency sweeps, this combination will work. The multiple offset short (or open) case also follows these rules as is evident from earlier chapters in this guide on SSST and SSLT calibrations.

The use of the load standard raises somewhat more complicated issues and is often only used in the 3-standards case. In the one standard case, it will raise uncertainties in the fixture insertion loss estimate if the load reflection coefficient is even close to as small as the mismatch of the fixture. In the two-standard case, similar issues happen except both the fixture match and insertion loss extractions can be imperiled. If the fixture is well-matched, the use of a load standard can improve the extraction of that mismatch.

.s1p files cover the gamut of the above possibilities but concept of independence still holds. The reflection coefficients of the various standards (in a complex sense) should be as far apart as possible for maximum accuracy.

The 'Classical open-short' selection is a special case of the 2-standards scenario where a zero offset open and short are used and the fixture arm is assumed to be electrically short. This assumption, most often used in on-wafer de-embedding scenarios, enables more detailed match information about the fixture/lead-in to be determined at the expense of generality.

In the space of this chapter, it would be difficult to cover the sensitivities for all possible combinations of fixture parameters and standards. We can, however, offer some examples that might illustrate some of the trends.

Consider the one standard case first where the fixture has 25 dB return loss (flat with frequency) and has 5 dB of insertion loss at 40 GHz (going to 0 dB at DC with a square-root-of-f dependence). In the first experiment, an open will be used and a Monte Carlo simulation run where the reflection coefficient magnitude (which should be 1) is allowed to vary $\pm 5\%$ and the phase is allowed to vary ± 10 degrees. The errors on extraction look like that shown in Figure 7-14. The width of the apparent trace gives the sensitivity to the standard changes which is quite slight. The macroscopic curve is the error for ignoring the fixture match (by using 1 standard only). Clearly the standard sensitivity is not a huge problem. Since the loss of the fixture gets closer to the mismatch at higher frequencies, the error increases.

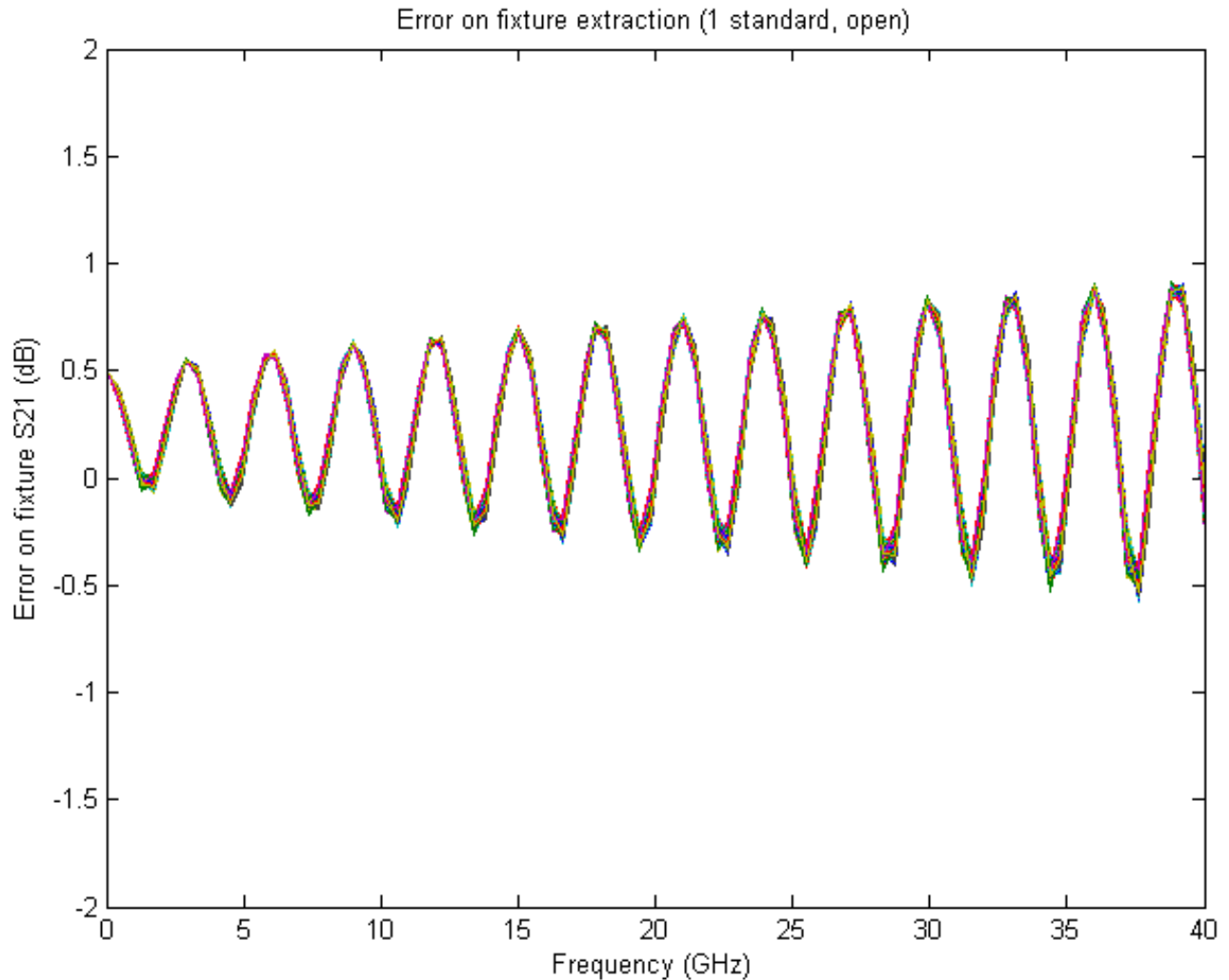

Figure 7-14. Error On Fixture Extraction (1 Standard, Open)

Now consider the case where the standard is a 20 dB return loss device and we run the same simulation. The standards sensitivity has increased in this case (width of the composite trace) although the scaling of the magnitude variations used may not have been comparable. The overall errors increased since the measured insertion loss contribution to the reflection measurement is now even smaller relative to the (ignored) fixture mismatch.

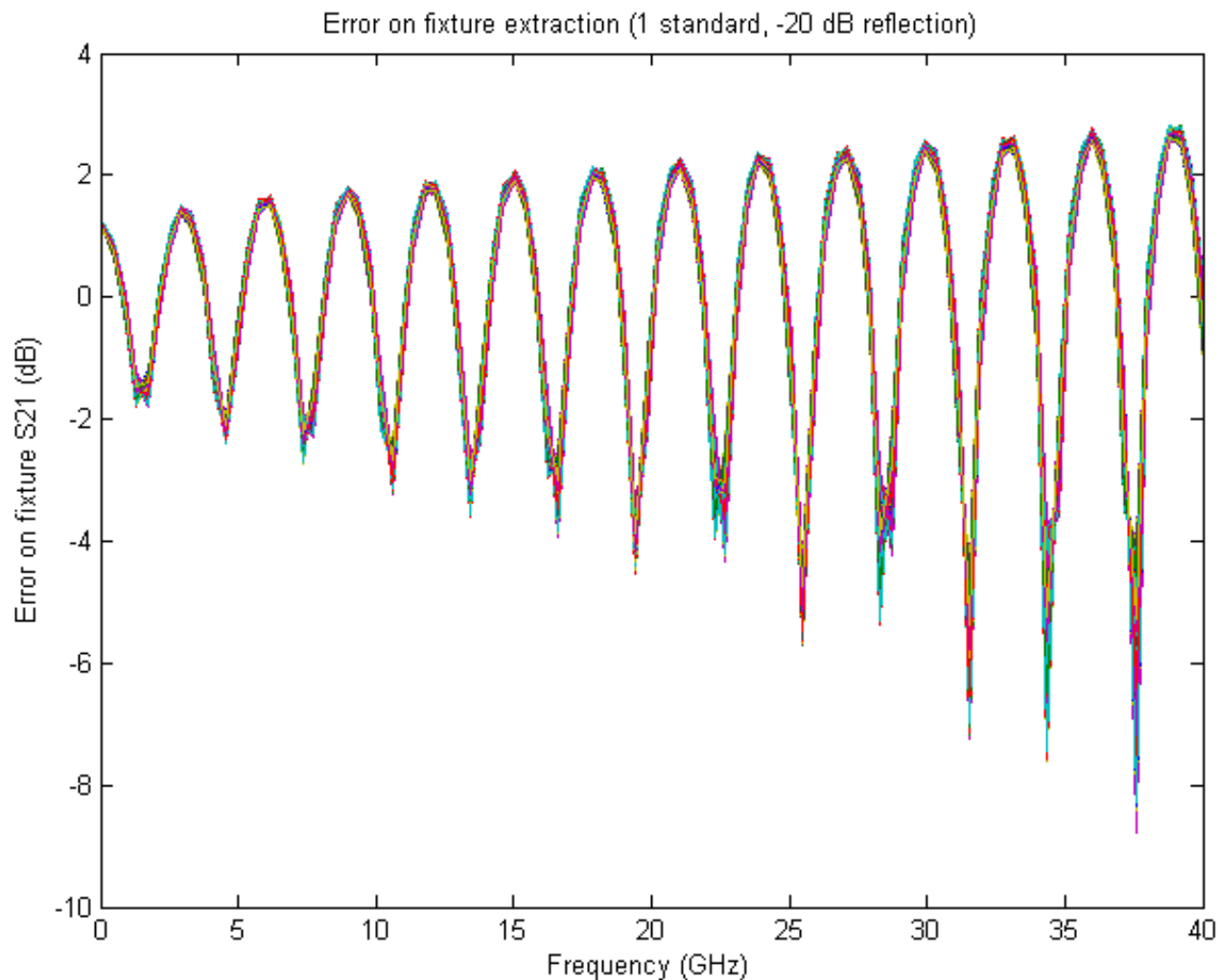

Figure 7-15. Error On Fixture Extraction (1 Standard, -20dB Reflection)

Moving to the two-standard case with roughly the same fixture (except now $|S_{11}| = -25$ dB and $|S_{22}| = -20$ dB). First, an open and a short were used with the same 5%, 10 degree parameter variation. The resulting errors are now much smaller since some mismatch is being accounted for. The standards sensitivity is now a much larger fraction of the error. The errors are also now larger at lower frequencies since the lower loss exposes the mismatch asymmetry of the fixture more to the measurement.

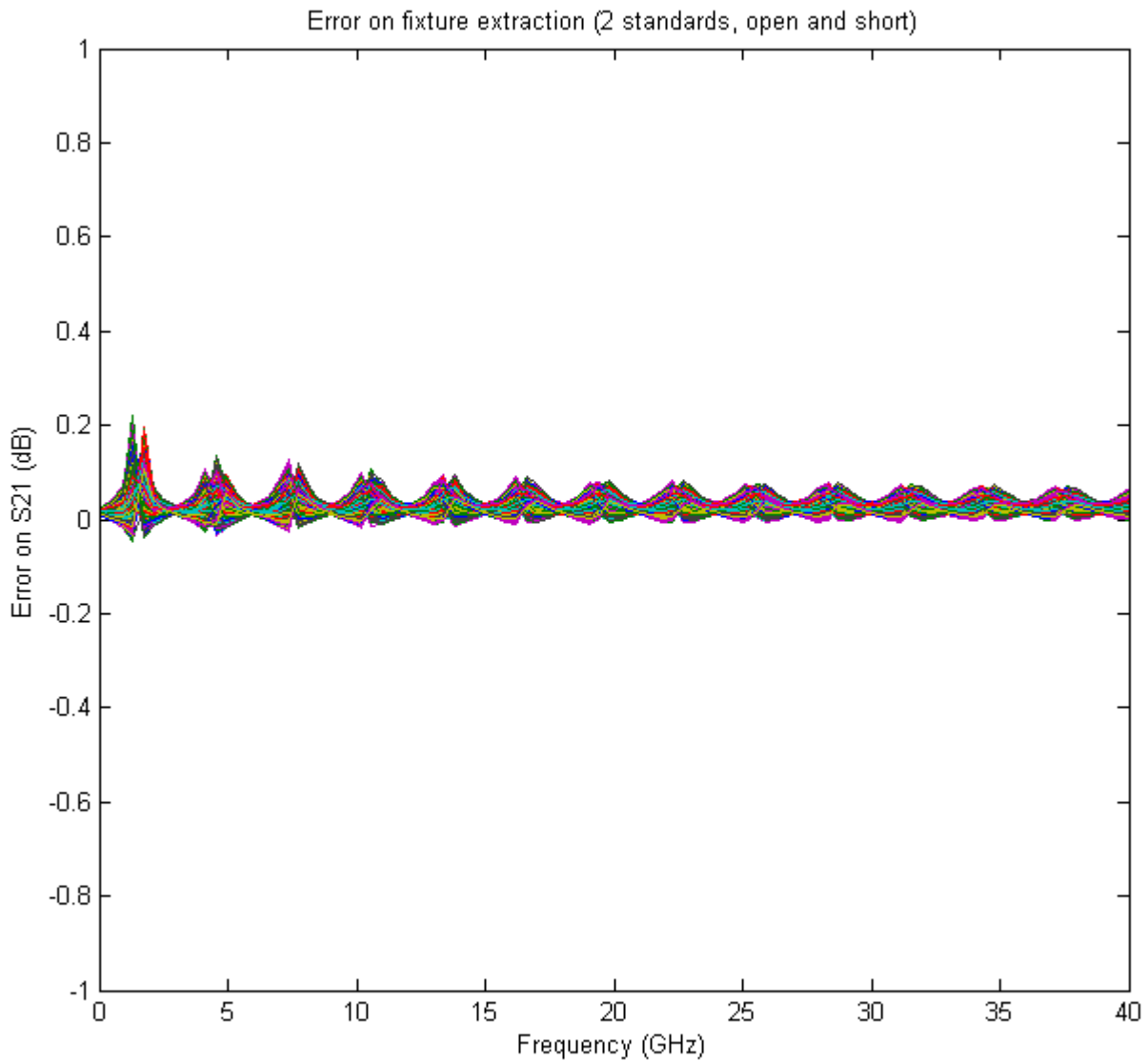

Figure 7-16. Error On Fixture Extraction (2 Standards, Open and Short)

If the 20 dB return loss device is substituted for the short, the profile changes dramatically. Since one of the standards is similar to the fixture match, the deconvolution of loss and mismatch extraction in this method breaks down somewhat so the error increases (although it is still much better than with one standard).

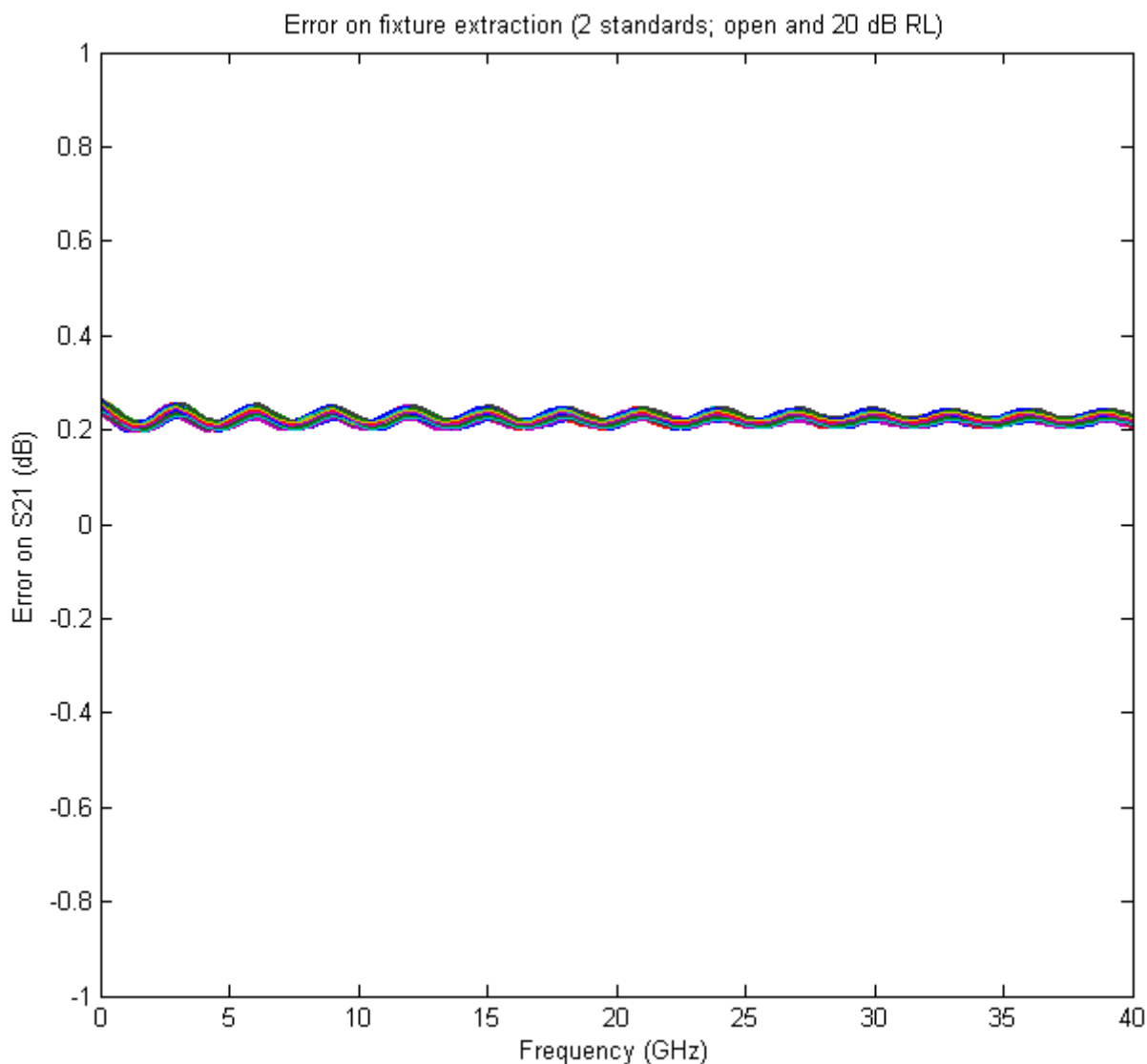

Figure 7-17. Error On Fixture Extraction (2 Standards, Open and 20 dB RL)

In the three-standard case, there are an even larger number of variations but, since the input and output match are being solved for independently, the sensitivity and errors will decrease as long as the standards level-of-knowledge remains constant. One example comparing one, two and three standards is shown in Figure 7-18. The mismatch of this fixture is relative symmetric and below -20 dB until about 10 GHz and degrades to about -10 dB by 20 GHz (and becomes less symmetric). One can see the one-standard approach starting to diverge relatively early as the fixture mismatch becomes increasingly significant relative to the insertion loss. The two-standard approach starts deviating later only when the match asymmetry becomes more significant.

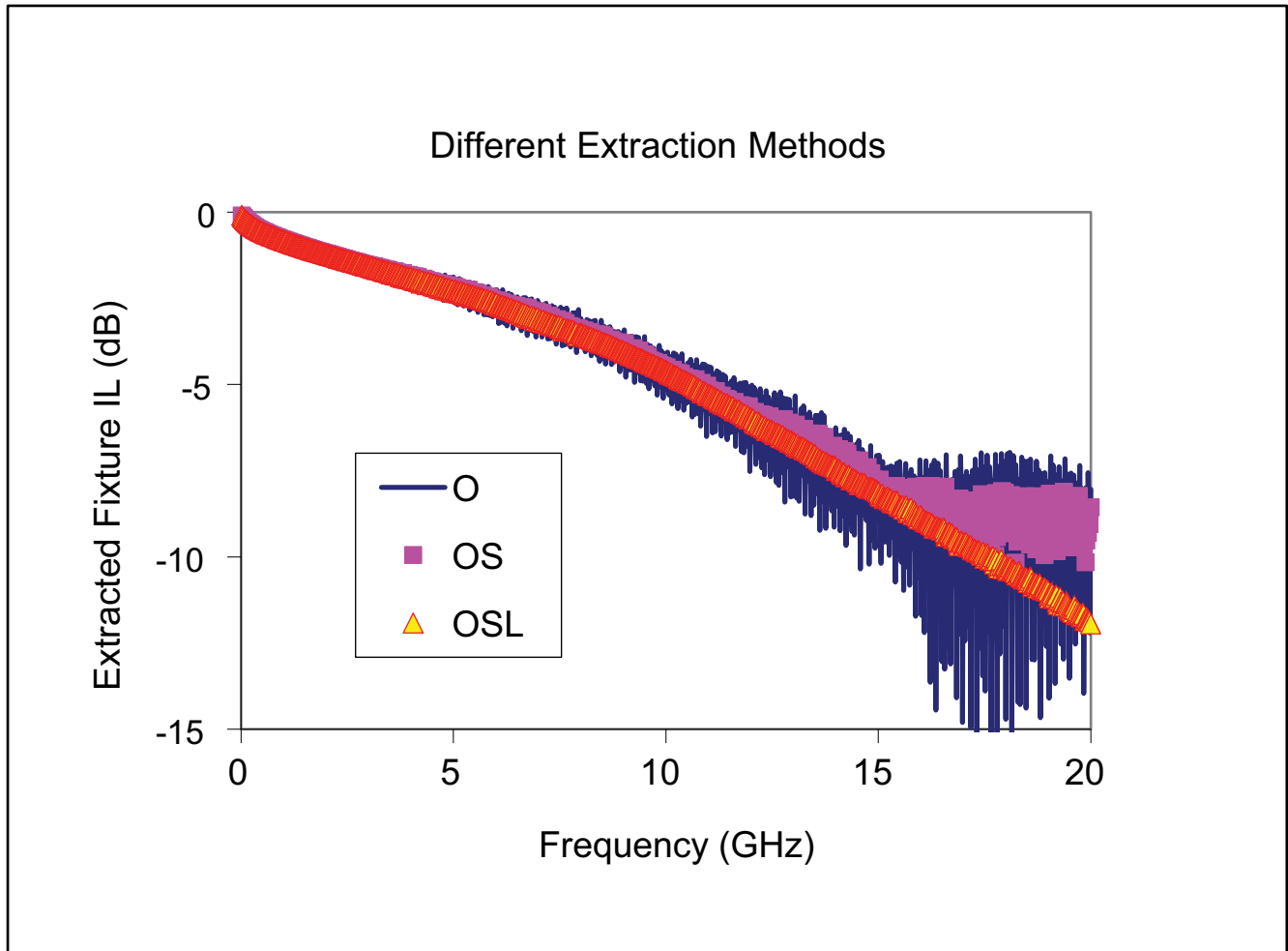

Figure 7-18. Extracted Fixture Example Comparing One, Two, and Three Standards

As a summary of all of the Type B permutations:

- A full standards version (or flex standards with 3 independent standards) can produce the best possible accuracy and lowest sensitivity but only if the standards are well-known. To put it another way, the 'performance ceiling' is the highest.
- Flex standards with two independent standards can do very well if the fixture arm is relatively symmetric and does particularly well when the insertion loss is low. An open-short pairing is the most common and is a favorite in on-wafer and micro-fixture applications. This approach fares less well with higher loss, asymmetric fixture arms.
- Flex standards with one standard is sometimes the only practical method due to the interface on the far end of the fixture. A high reflection is the best choice for that standard usually unless the fixture is exceptionally well-matched. This approach is most accurate when the fixture mismatch is very low.

Quick Extract

The Quick Extract check box disables the file entry fields and instead saves the output file to a pre-determined location and automatically starts the de-embedding engine. The file just saved will automatically be loaded into the de-embedder (where it can be edited). This process can help save time if the desire is to immediately de-embed a fixture that was just extracted. Note that any de-embedding in place prior to the extraction will be cleared (and the system will warn if this is about to happen). If de-embedding was on when extraction was run, those de-embedded values will be used during extraction so some caution is advised as it is possible to partially negate an extraction by using already partially de-embedded data.

7-7 Type C Network Extraction

Type C is the most complete, dual fixture extraction approach offered in the VNA. It requires full 2-Port calibrations at two sets of reference planes but can fully determine the S-parameters of two networks independently.

Consider the diagram in NETWORK EXTRACTION dialog box (see [Figure 7-7](#)). A calibration is required at the outer reference plane set and the inner reference plane set. The outer calibration can usually be done coaxially (or some other well-defined media) depending on the networks involved. The inner calibration is often more complicated and may be board- or wafer-level (and may require the user create calibration standards). Assuming these calibrations are possible, then the S-parameters of Network 1 and Network 2 can be found.

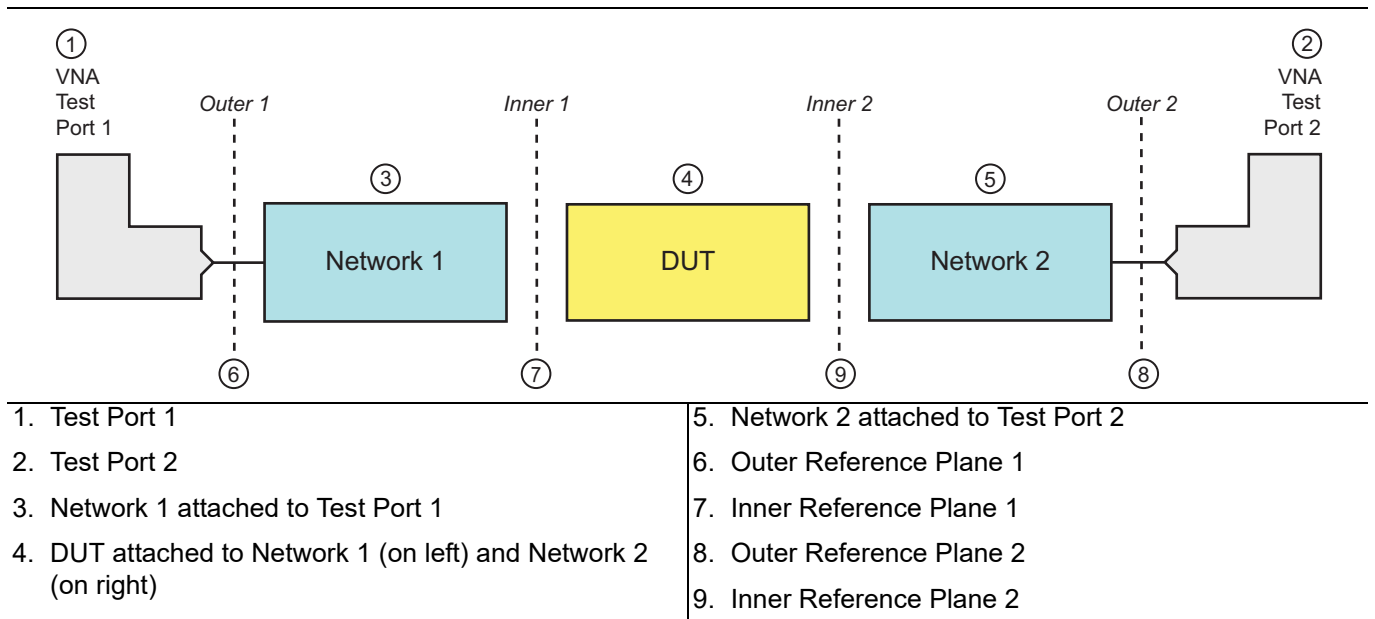

Figure 7-19. Network Extraction Process Diagram for Type C Networks

Two port calibrations at two different reference plane sets are used to extract the S-parameters of the intervening networks (often test fixtures). The dialog for loading the two calibrations is shown in NETWORK EXTRACTION [Extract Two 2-Port Networks (Type C)] dialog box in [Figure 7-20](#).

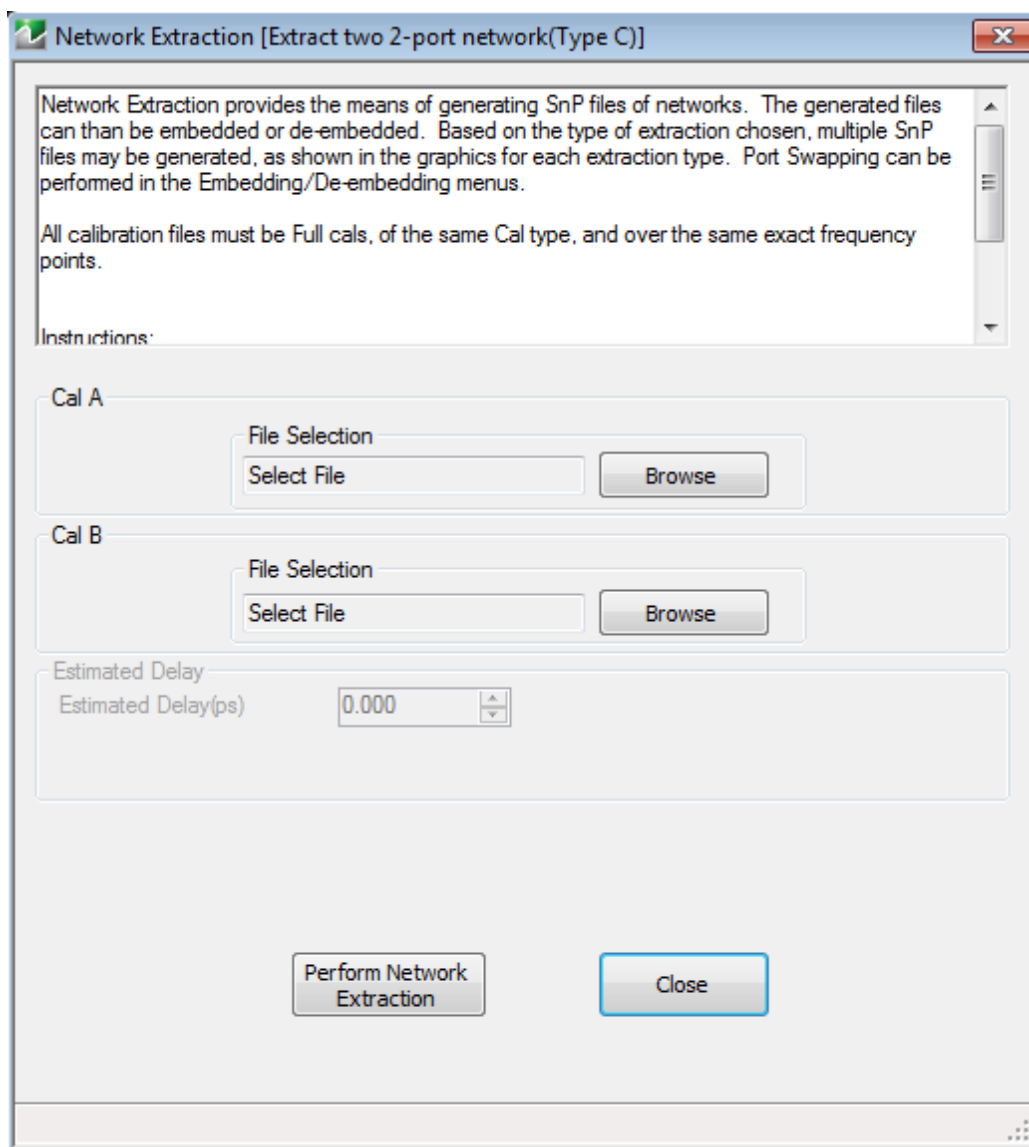

Figure 7-20. NETWORK EXTRACTION Dialog Box—Extract Two 2-Port Networks—Type C

As before, the two calibrations are performed and the setups saved, typically as an active channel CHX file type.

Some conditions:

- The two calibrations must be full 2-Port cals and must have the same frequency lists.
- After extraction is performed, a file dialog will appear allowing the user to indicate where the S2P files should be stored.
- The networks are assumed to be reciprocal.

Unlike Types A and B, this method determines the two fixture halves completely and independently. As a trade-off, a complete set of standards at the inner plane are now required. Algorithmically, this type is very similar to Type A except two networks are processed simultaneously. If the inner cal standards can be successfully made/acquired, the inner match values extracted will typically be more stable than those acquired with a Type B analysis for the reasons discussed in the previous section.

7-8 Type D Network Extraction

The dialog is a very simple one and is shown in [Figure 7-21](#). The outer calibration should be active when this procedure is called since files are not recalled as with the other techniques. Because it is sometimes difficult to allocate or interpret the match terms, a check box is provided to ignore those terms altogether. In this case, $S_{11} = S_{22} = 0$ (linear) in the exported S2P file. As with the other techniques, a dialog will appear upon execution to allowing the naming of the destination S2P file.

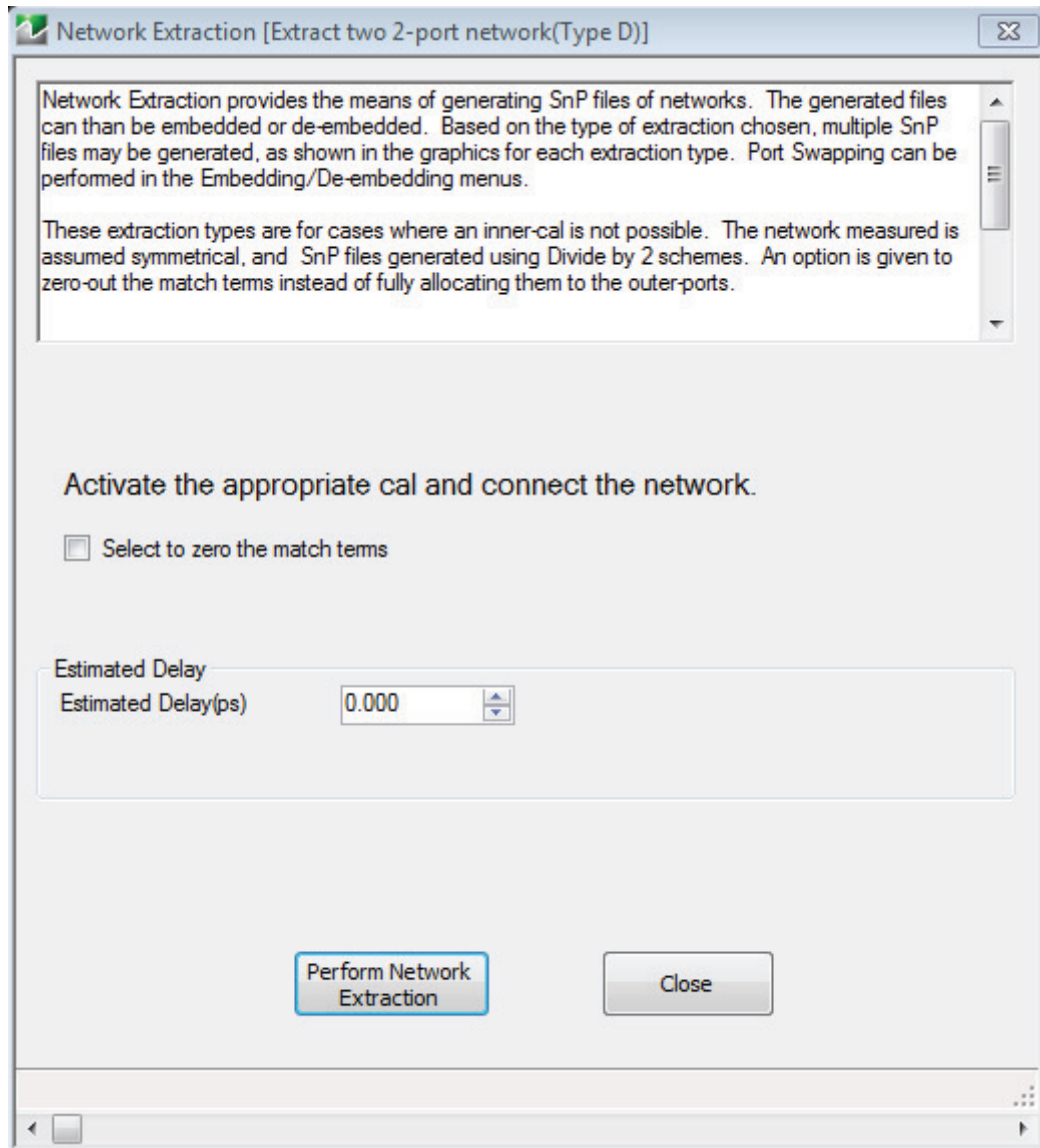

Figure 7-21. NETWORK EXTRACTION Dialog Box—Extract Two 2-Port Networks—Type D (without Option 24)

Type D Network Extraction—Multi Standards (with Option 24)

Type D is considerably different from the other techniques (except some configurations of flexible standards in Type B) in that it relies only on a limited number (1-3) of measurements to extract parameters rather than relying on the manipulation of a pair of calibrations. A full 2-port calibration is performed at the outer planes (often in coax or waveguide or with on-wafer probes) and then simple standards (one or more lines and possibly a single high-reflect standard) are connected between the fixture halves as suggested in Figure 7-22. The non-Option-24 version of Type D differs in that only a single line standard is allowed and its length must be 0.

This technique belongs to a class of approaches that have been termed ‘partial information techniques’ since they make additional assumptions about the fixture to avoid the necessity of a full calibration at the inner plane. As such, these techniques are particularly attractive when the inner plane has a complex structure or geometry that makes it difficult to create many standards for that plane or difficult to accurately model those standards. There are also cases where such methods are useful because the repeatability of connection at the inner plane is degraded. By de-emphasizing inner plane match in those cases, sensitivity to repeatability issues can be reduced.

There are a number of different ways to use Type D and this section will explore the differences and how one might choose the sub-approach to take. In earlier versions of the ShockLine software (prior to software release V2019.7.1), only one choice was available: the use of a zero-length thru between back-to-back fixture halves which assumed that the halves were identical and had perfect match at the inner plane. That sub-approach is still available, as will be seen, but there is now more flexibility.

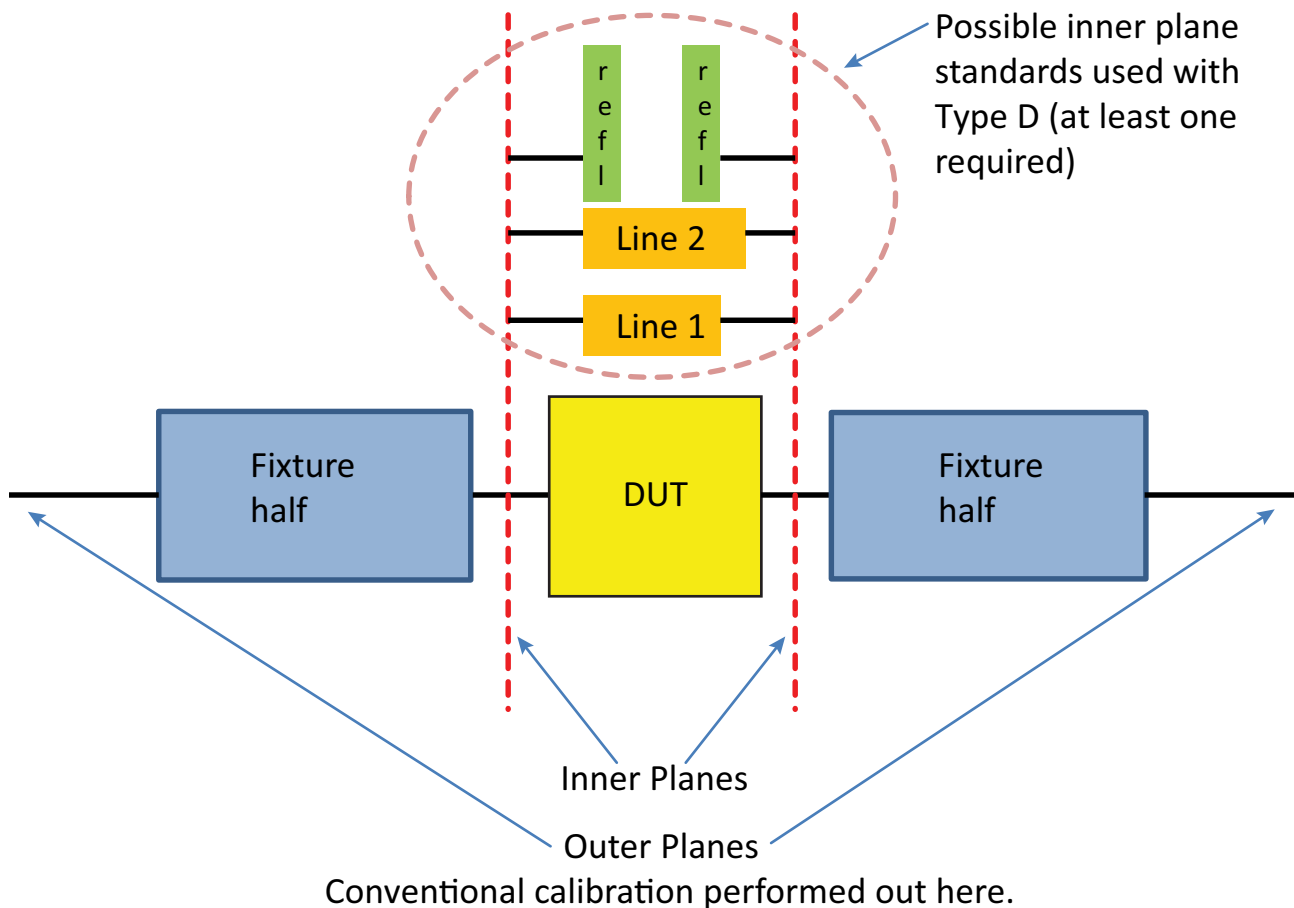

The basic structure of Type D extraction is shown here. There is considerable choice in the standards used at the inner plane but the combinations all share the fact that the set is not ‘complete’ in the sense of a full calibration at that plane. Some fixed error is accepted in exchange for simpler standards and more immunity to repeatability issues.

Figure 7-22. Network Extraction Type D

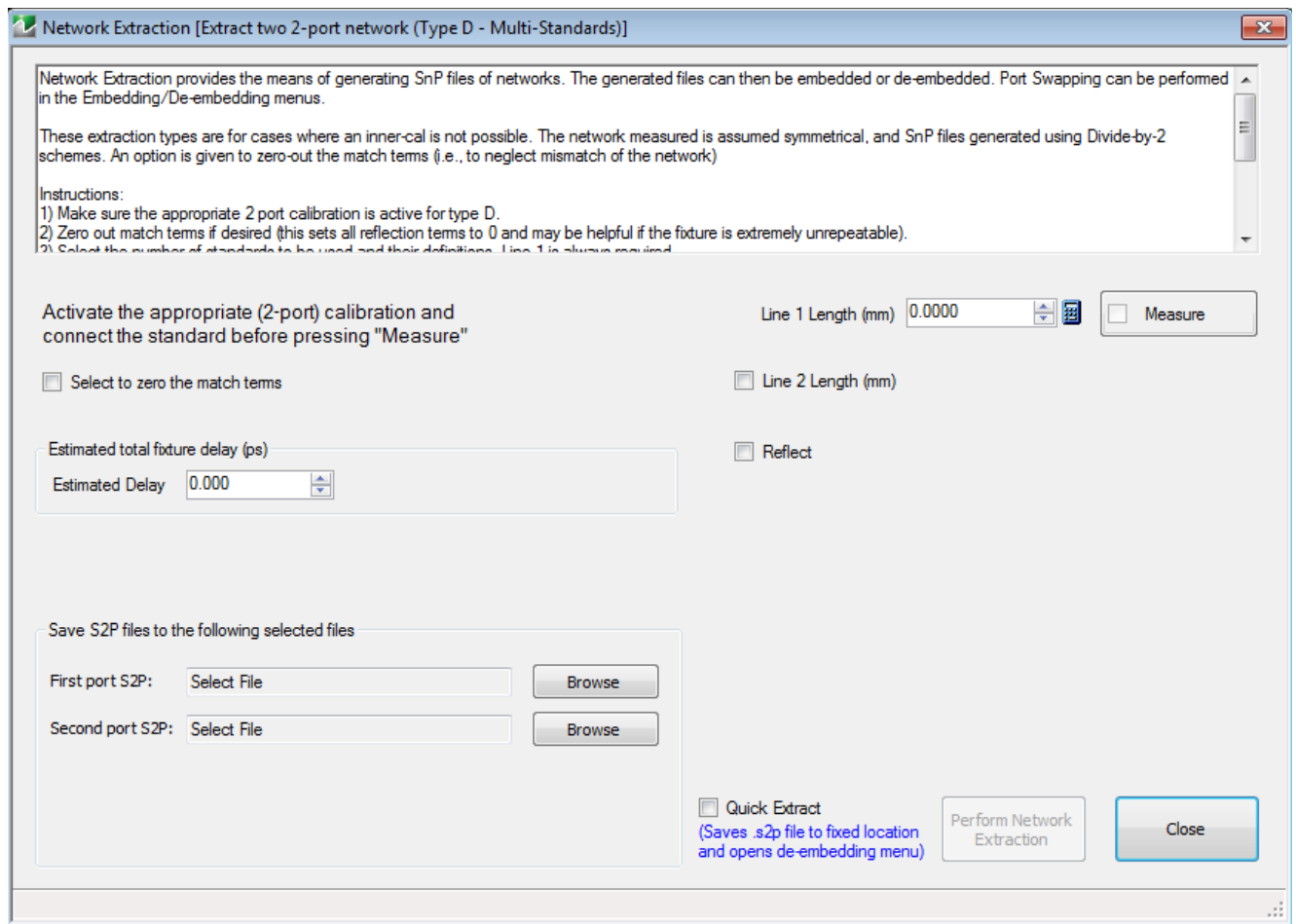

Figure 7-23. NETWORK EXTRACTION Dialog Box Type D Multi-Standards (With Option 24)

The basic Type D extraction starts with a line between fixture halves as mentioned and will assume symmetry of the fixture halves. This line can have any length but that length must be specified and any errors in that specification will map through to the phase lengths of the extracted fixtures. If one stops here, the mismatch at the inner planes of the fixture will be ignored (S_{22} will be zero in the extracted files). One can also elect to set all match terms to zero and that will force both S_{11} and S_{22} to zero no matter how many standards are used. This zero-match choice can be useful if repeatability at the inner plane is particularly poor and insertion loss/phase correction for the fixture is the primary concern (doing a closer-to-full match correction with a very non-repeatable interface can often further reduce the transmission extraction accuracy). A fixture length entry is requested (represents both halves together) and this is used just for root selection so precision is not normally required. If zero is entered for the fixture length, an automatic routine (similar to auto reference plane extension discussed in [Chapter 9, "Calibration and Measurement Enhancements"](#) of this guide) is used to estimate the length.

One can also add a second line of some different length (and its transmission amplitude can be entered independently) and inner plane match will no longer be ignored. Note, however, that the accuracy of the entered line lengths is more important in this case. Also, the line length difference between the first and second lines should not approach 180 degrees within the frequency range of interest (or be too close to 0). Generally, the line length difference should be between ~ 10 and 160 degrees over the frequency range of concern.

The use of reflection standards (which must be placed on the inner planes of both fixture halves) will also allow for solving for inner plane match. Finally, one can use all three standards which will generally improve accuracy on both insertion loss and inner plane match. The choice on how many of the standards to use should depend on how well those standards can be made (e.g., can a second line length be made that is still relatively well-matched as a transmission line, can reflect standards be made that have relatively uniform reflection magnitude over the frequency range of interest, etc.). Implicit in this is that the measured characteristics going from the first standard to the second standard do not change for other reasons (e.g., if the structures being measured are different implementations of the same fixture, then they must be quite identical). Generally, if additional standards perform well in this sense, using them will improve the overall extraction.

As an example, consider the measurement of a back-to-back cable assembly where two different thru lengths are possible at the inner plane (0 and 24 mm). If one compares the single line approach to the two line approach on extracted insertion loss, one can see some differences (Figure 7-24). The single line approach produces an insertion loss with slightly more ripple and a slightly more optimistic overall value (although errors in either direction are possible).

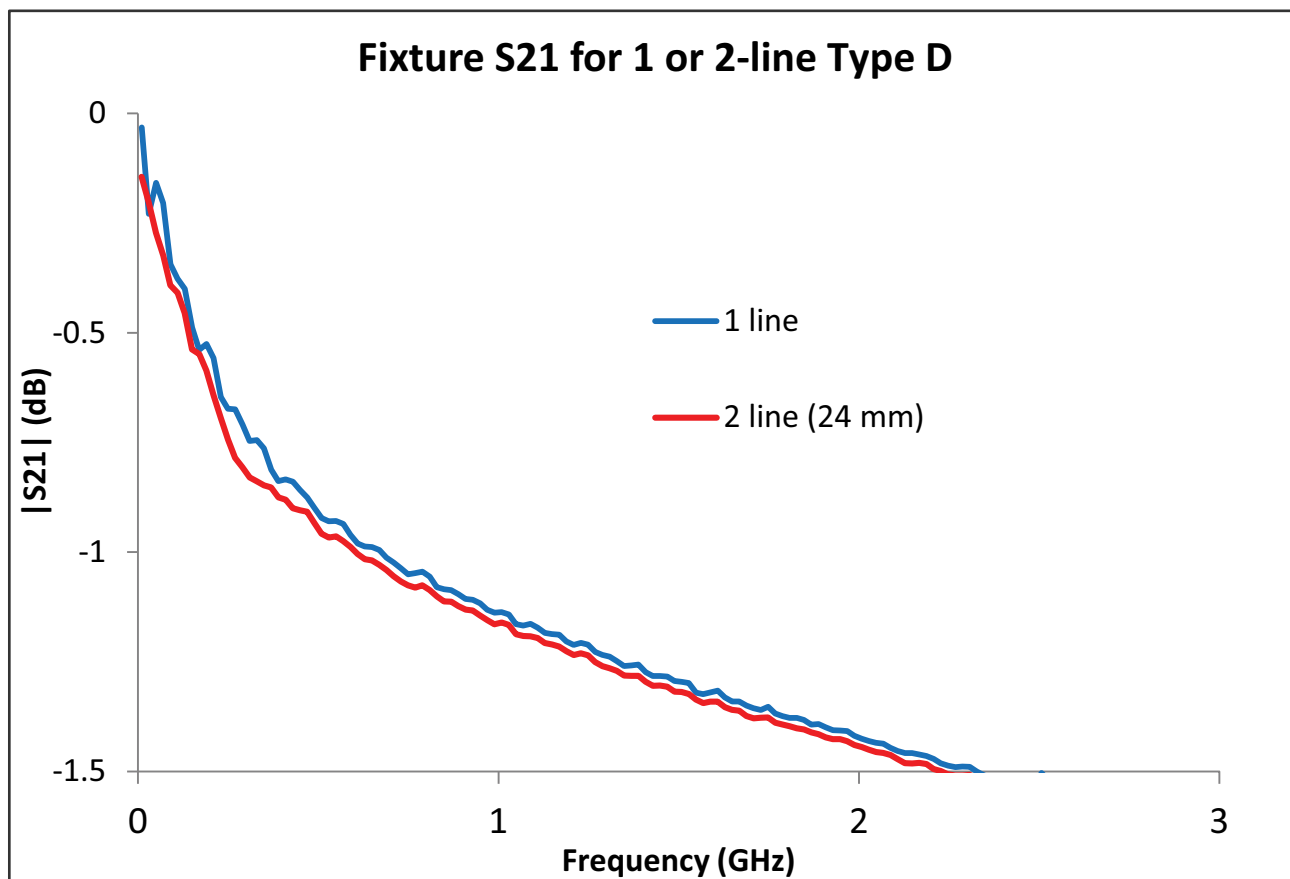

A comparison of single and double line Type D extractions of insertion loss are shown here. With a correct standard length entry and sufficient repeatability, the double-line method can increase accuracy of the extraction.

Figure 7-24. Comparison of Single and Double Line Type D Extractions of Insertion Loss

If the entry of the standard line length is not accurate, however, substantial errors can result. The extraction of the previous figure is repeated in [Figure 7-25](#) for the added cases when the 2nd line length is off by ~10 or 20 %. The errors are a few tenths of a dB at low frequency but grow larger at high frequencies as the standing wave that is being corrected grows more dense. Also, in this case, the 28 mm entry brings a singularity to lower frequencies and this has an even more substantial effect on the error.

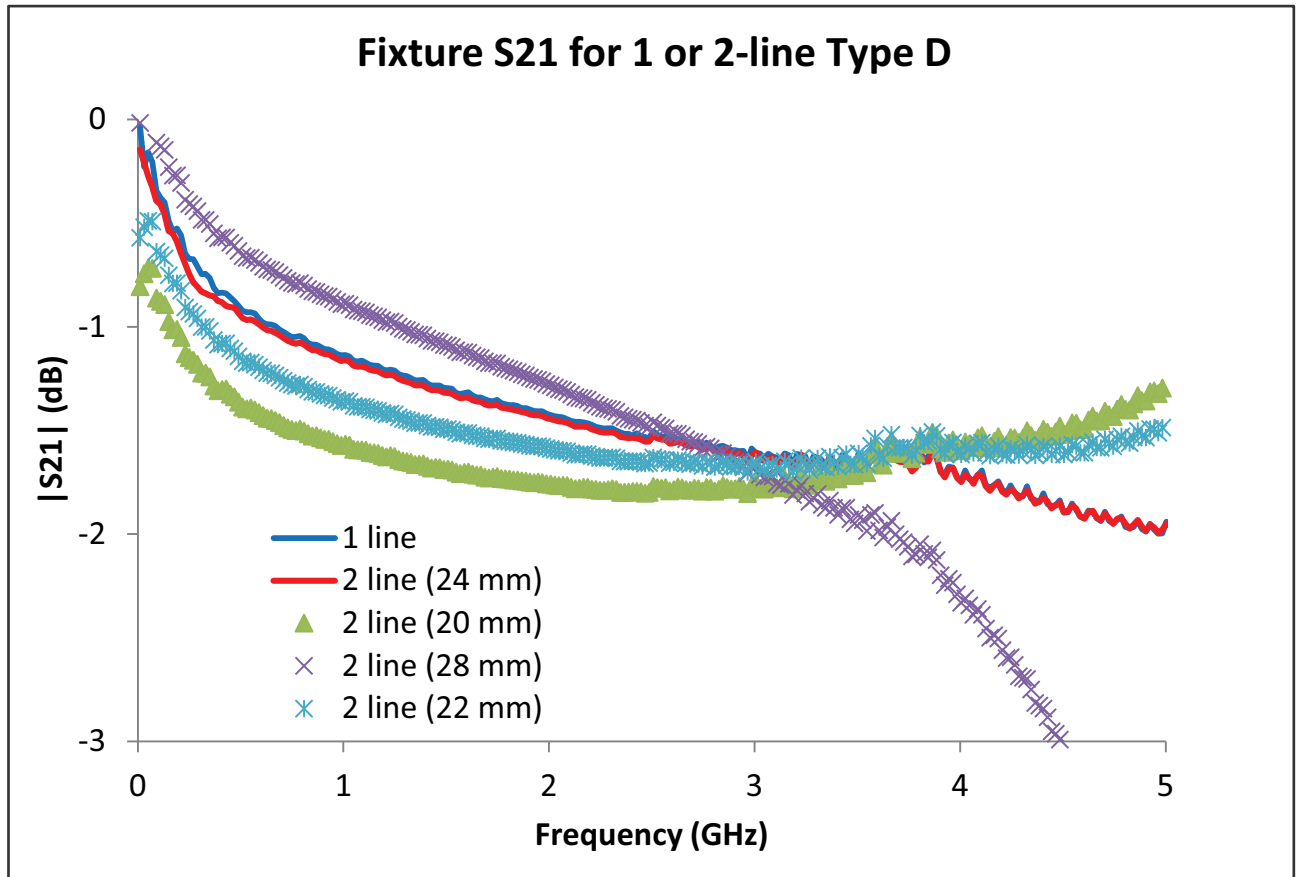

The results of [Figure 7-24](#) are augmented here with two line cases when the entered length of the second line is incorrect (correct value is 24 mm).

Figure 7-25. Resulting Error with Inaccurate Standard Line Length Entry

One reason for using the two line approach (or line+reflect) is to get more reasonable values for inner plane match which can be important for sequential de-embedding and modeling. Again, the parameter entry accuracy is important for the inner plane match as it was for insertion loss extraction. The inner plane match values for the fixture of Figure 7-25 are shown in Figure 7-26 for the same length entries.

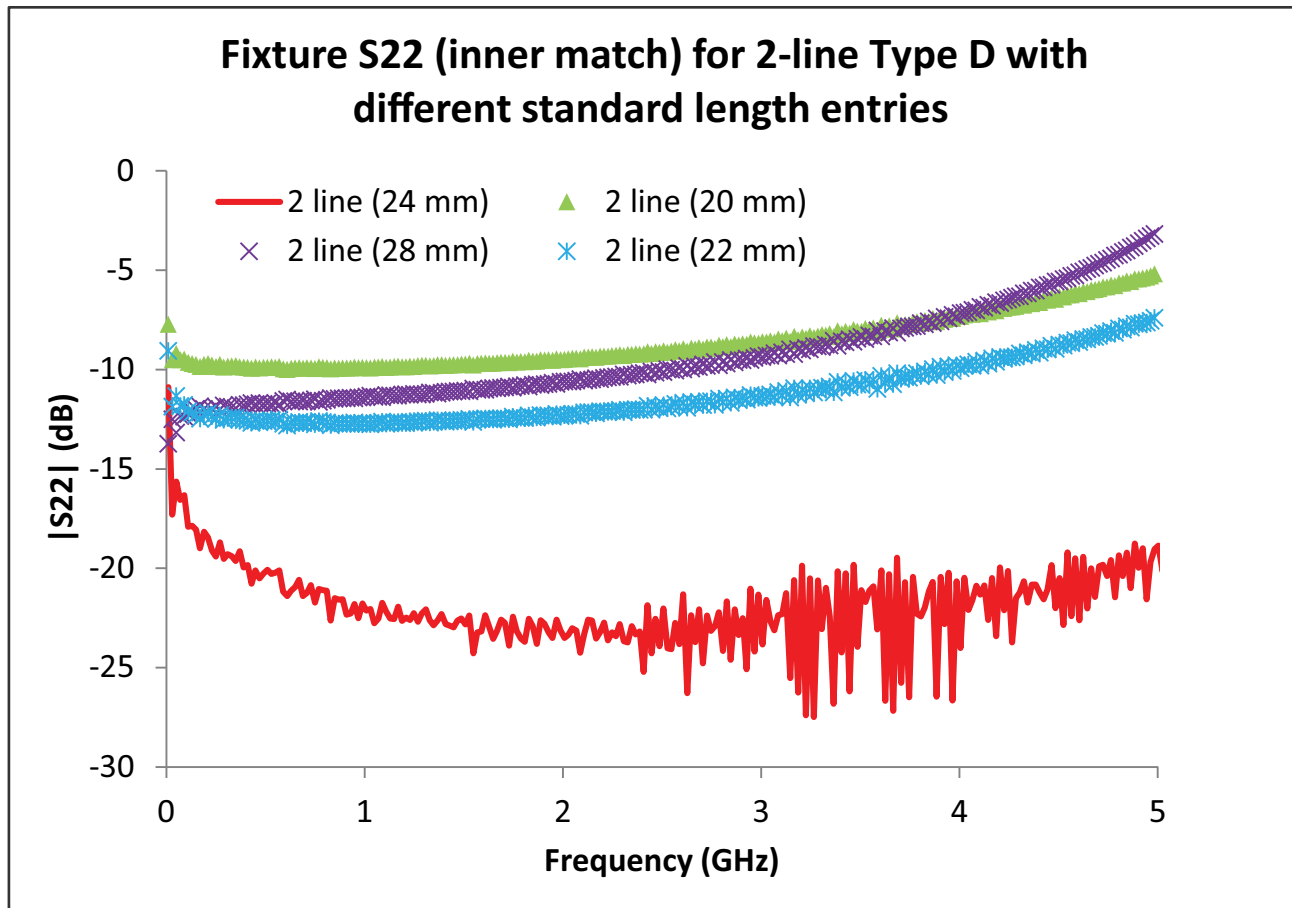

The inner plane match values for the experiment of Figure 7-25 are shown here. Even a 10% length entry error causes ~10 dB errors in return loss.

Figure 7-26. Inner Plane Match Values

The single-line version of Type D is best obviously for well-matched fixtures relative to loss (i.e., very well matched if low loss and moderately well-matched for moderate loss). With a 20 dB return loss, there will be generally 0.3 dB or more of insertion loss uncertainty with this technique (as opposed to $\sim < 0.1$ dB with other techniques if good standards are available). With a 10 dB return loss fixture, it will be several dB of uncertainty. With additional standards (assuming accuracy of length entries and sufficient repeatability), the method becomes more mismatch tolerant—often keeping errors under 1 dB for a 10 dB return loss fixture—but the results will still be worse in an absolute sense than with a complete method (assuming the latter was possible).

Additional Notes Regarding Type D—Multi-standards

- A full 2-port calibration must be active and the extraction will be run over that frequency range.
- The line and reflect offset lengths are entered in millimeters, although a calculator is available if values are in picoseconds. If the material type is set up (from the current calibration or manually thereafter), that and any active dispersion relations will be used in the calculations. In two-line cases, the first and second lines must be electrically distinct (i.e., phase length differences not too close to 0 or 180 degrees within the frequency range of interest).
- -The Quick Extract feature (allowed on all type D variations with Option 24) suppresses the file name entry fields and instead saves the files to a predetermined location, automatically opens the de-embedding engine, and loads the just-generated files into the de-embedder. These entries can be changed at that time if desired, but this process can save time if the desire is to immediately de-embed a fixture that was just extracted.
- The Measure buttons are used to measure the two fixture halves with the appropriate standard connected and those standards must be connected when the relevant Measure button is pressed. The system will trigger a channel sweep at that time to acquire new data.

Type D Network Extraction—Phase Localized (with Option 24)

Another variation of Type D is termed ‘Phase Localized’, where a single standard (either a line or a reflect/reflect pair) is used along with the assumption that the fixture is electrically long enough (based on the frequency range being used) and the bulk of the fixture mismatch is not too close to the inner plane. The dialog for setting up phase localized extraction is shown in [Figure 7-27](#).

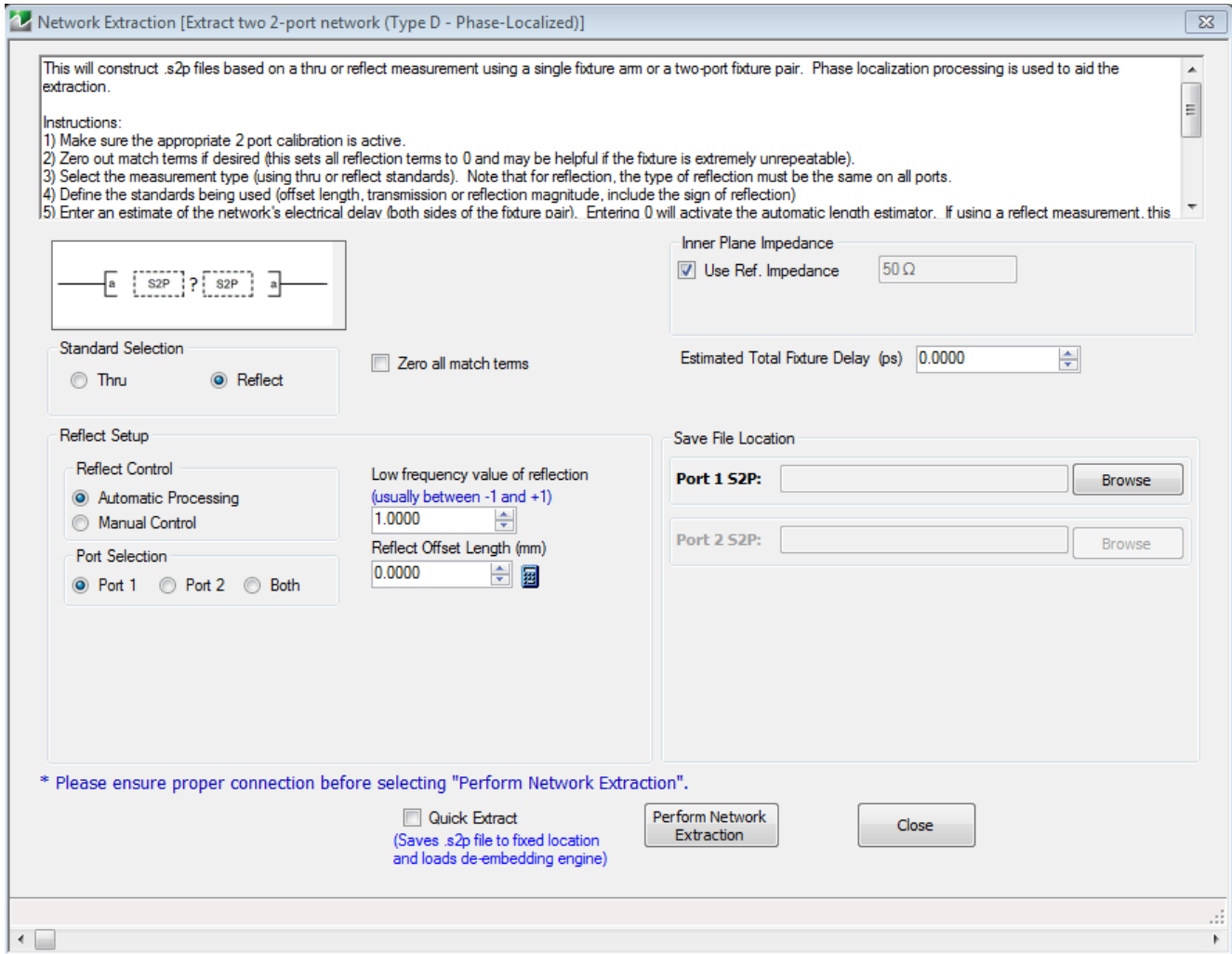

Figure 7-27. NETWORK EXTRACTION Dialog—Type D—Phase Localized (With Option 24)

If the assumptions are met, this method can outperform the previously discussed Type D variations. More central to this method is the fixture length as transmission-line-like: functions are cross-correlated with the measured data to better isolate insertion loss and reflection coefficients of the fixture halves. If the fixture length entry is set to zero, an automatic process (much like auto reference plane delay discussed in [Chapter 9, “Calibration and Measurement Enhancements”](#) of this guide) will estimate the length. As before, entries for the line length or reflect offset length are required and any errors in those values will translate to extracted parameter phase. If the line is chosen as the standard, symmetry between the fixture halves in terms of insertion loss will be assumed. If the reflect standard is chosen, no symmetry is assumed and only one half of the fixture can be extracted if desired. If both halves are to be extracted, length estimates for the individual arms can be entered. In this variation of Type D, there is no Measure button and the measurement is executed when Perform Network Extraction is selected.

As an example, consider a fixture consisting of a ~50 mm microstrip line, a coaxial launcher on one end and a DUT-local launcher on the other end (for each arm of the composite fixture). Suppose only an open standard is available and one would like to use the phase-localized approach since there was only the one standard and it was believed that most of the mismatch was away from the DUT interface. In this case, it was possible to do a complete calibration at the inner reference plane so a comparison was possible. The extracted vs. nominal insertion loss is shown in Figure 7-28. One can see pretty good agreement until about 30 GHz when it did work out that DUT-plane mismatch on the fixture was getting large. Further, the fixture started having significant radiation above about 35 GHz which further complicated the extraction. The return loss (extracted and nominal again) values are also plotted in Figure 7-28 and again show reasonable agreement until the very high frequencies. Recall that uncertainty in return loss in dB terms gets much larger as the match gets very good just based on a residual directivity argument (a few dB at the -20 dB level for a decent coaxial calibration).

This example does reinforce a couple of points:

- Partial information methods do have some fixed error because of the incomplete ‘calibration’ at the inner plane
- The further the fixture deviates from the ideal aspects assumed by the method (where mismatch is located in this case), the larger those errors become.

Still, if it was indeed only possible to have an open standard for this fixture, the results shown here are better than one could achieve with a single-standard generalized B method or with a simple normalization.

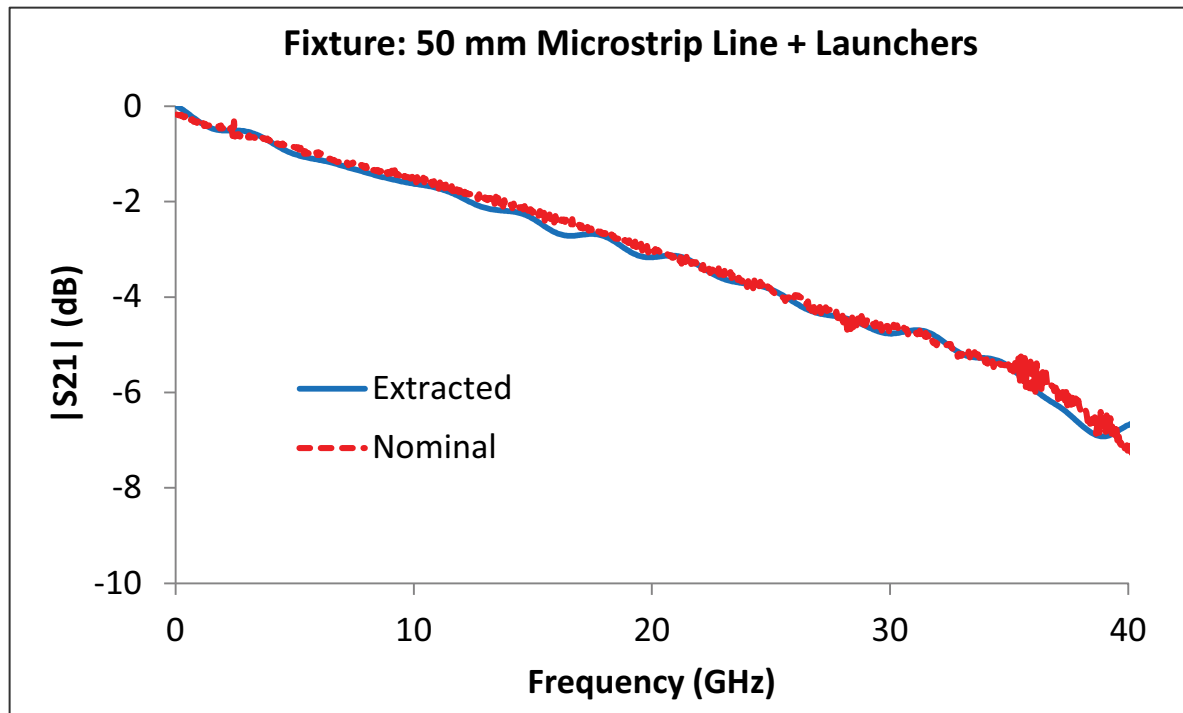
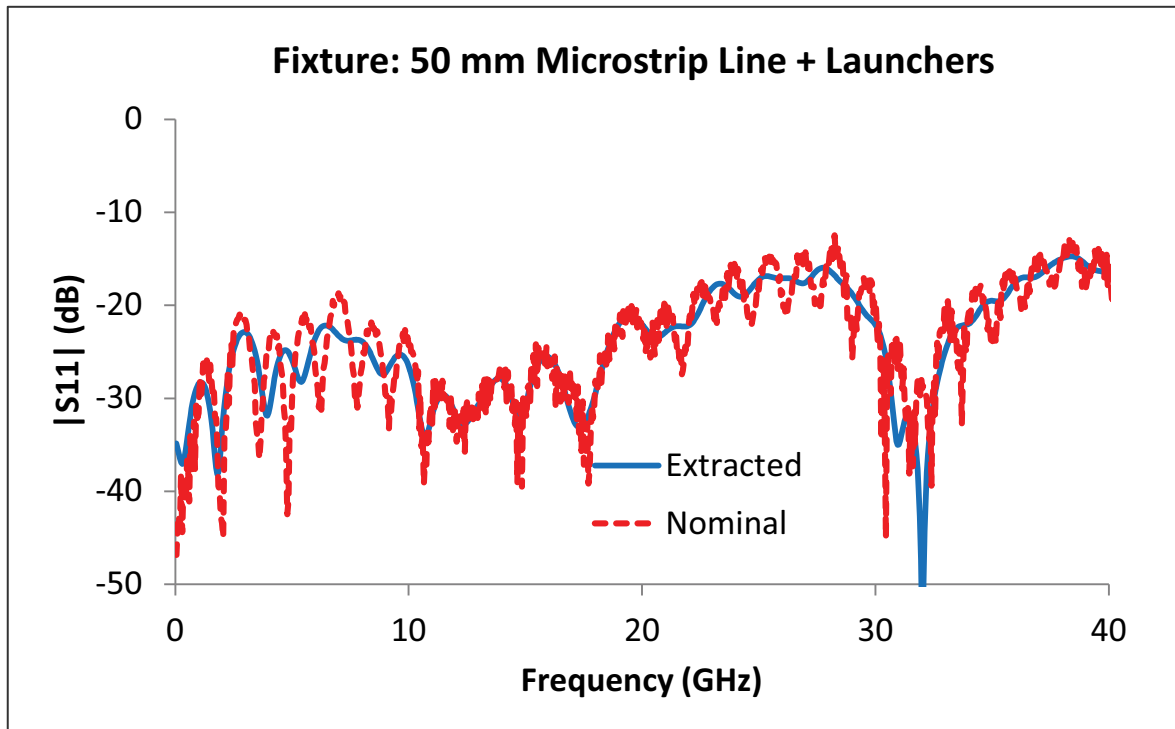

Figure 7-28. Microstrip Line Example (1 of 2)



The results for a phase-localized Type D extraction are shown here along with nominal results for a special case when both port of the fixture arm were connectorized (to allow for comparison). The extraction degrades at higher frequency as fixture radiation and inner-plane mismatch hamper the partial information technique. Only an open reflection was used for the extraction process.

Figure 7-28. Microstrip Line Example (2 of 2)

The direct sensitivity to standards definition defects are fairly straightforward since the reflection or transmission coefficient entered is applied multiplicatively to the data prior to a square-root operation. More subtle are non-idealities in the standards (such as mismatch of the line/thru standard). This will have impact through its influence on actual insertion loss during the measurement (in terms of an offset loss and in terms of ripple). Also on the subtle side are the effects of an incorrect fixture length entry. While in normal Type D this is mainly used for root choice, it is used in phase-localized D to determine which phase signatures to correlate against so entering a significantly incorrect value (10s of mm generally) can cause added ripple and, eventually, drop outs in insertion loss extractions as well as incorrect return loss values. The internal length estimate approach (entering 0 in the fixture length estimate field triggers this) can reduce the issues and is recommended unless the fixture phase response is very resonant, in which case a proper manual estimate will yield better results. The issue of where the mismatch is predominantly located was touched on earlier. This has somewhat more of an effect when using the reflect standard (since the fixture mismatch and the reflect standard are almost co-located so phase localization becomes difficult) than using the thru/line standard. As an example, consider the extraction of a microstrip section using a flush open reflect standard native and when the mismatch near that standard has been distorted from the original ~ -15 dB to ~ -5 dB at high frequencies. The effects on fixture $|S_{21}|$ are shown in Figure 7-29: added ripple and some substantial differences above 30 GHz (where the mismatch change was the largest).

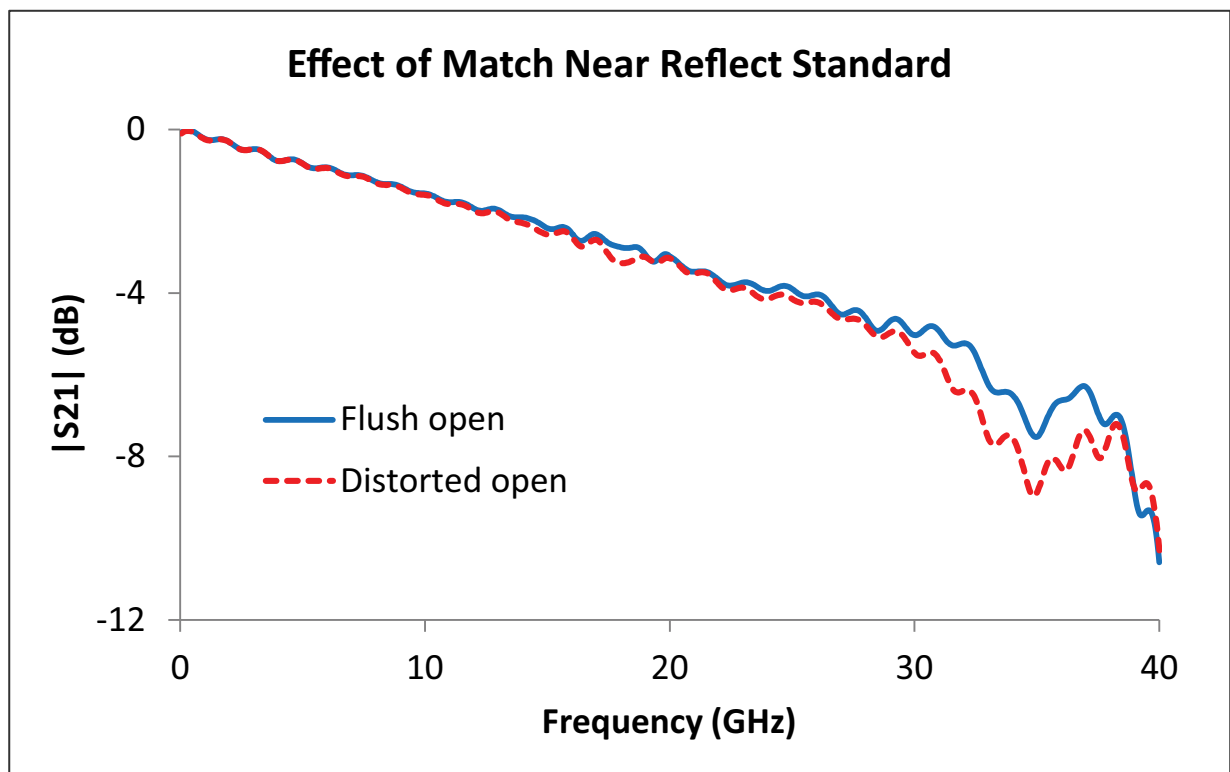

To further explore the sensitivity to inner-plane mismatch, a (reflect-based) phase-localized D extraction was performed on an original fixture and again after additional mismatch was introduced. In the range of additional mismatch addition, the discrepancies increased as expected.

Figure 7-29. Inner Plane Match Values

Fixtures with distinct impedance changes, intentionally constructed or otherwise, present an additional challenge. Consider a fixture where the inner plane is at 25 ohms and a thru standard is used for the extraction. If the inner plane impedance is ignored, then one is essentially treating the half fixture as being terminated in a 25 ohm impedance (low reflection for that zone) but that is implicitly changing the reference impedance of the S-parameter matrix. While this may sometimes be desired, it will cause errors if not anticipated when using that file for later de-embedding of modeling. More conventional is to keep the reference impedance (of the matrix) consistent at 50 ohms to facilitate later processing. In this case, the difference in the match parameters is substantial as shown in Figure 7-30.

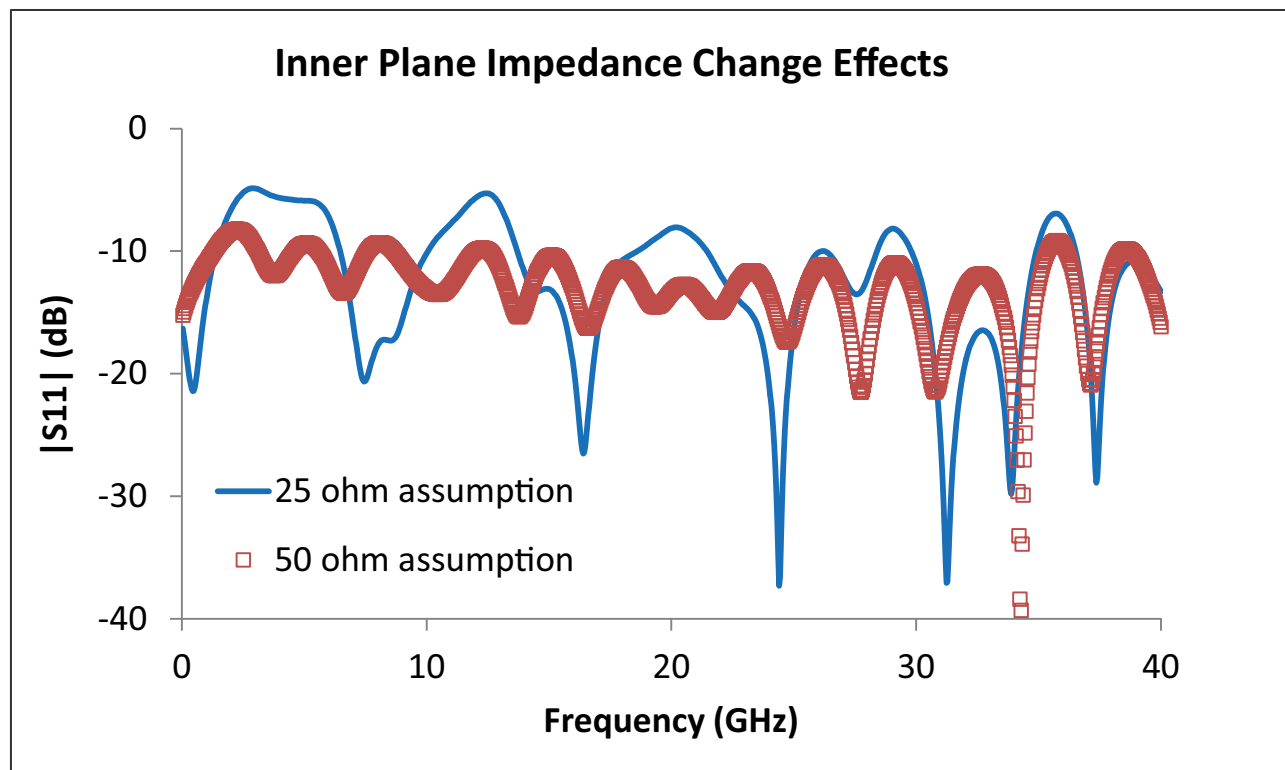

In a (thru-based) phase-localized D extraction, inner plane impedance deviations can create issues if large enough. In this case, the inner plane was at 25 ohms while the launch (and reference impedance for the calibration) was 50 ohms. If the impedance change was ignored (red squares in the plot), the extracted return loss for the fixture half can be significantly in error.

Figure 7-30. Phase Localized Type D Extraction—Effects of Inner Plane Impedance Change

Additional Notes:

- A full 2-port calibration must be active and the extraction will be run over the current frequency range (which is a subset usually of the calibration frequency range). For 4-port systems, at least a full 2-port calibration must be active. There is a requirement that the frequency list have nearly uniform frequency steps (an individual step size cannot deviate from the mean by more than 5%) so some segmented sweep setups (and all log sweep and CW setups) will not be accepted.
- The frequency range of the sweep should be large enough that the total fixture length (ns) $> 5 / (\text{frequency range (GHz)})$. The frequency step should be small enough that the total fixture length (ns) $< 0.3 / (\text{Frequency step (GHz)})$. This helps avoid insufficient phase slope or phase-wrap-aliasing (respectively) that would complicate phase localization.
- The line and reflect offset lengths are entered in millimeters although a calculator is available if values are in picoseconds. If the material type is setup (from the current calibration or manually thereafter), that and any active dispersion relations will be used in the calculations.

- The extracted results are stored as .s2p files with port 1 of each file being the outer plane. Details of the file format options (frequency units, etc.) are set by the entries on the sNp setup dialog. See [Table 7-1](#) for recommendations of extraction types and standards needed for various fixture behaviors.

Table 7-1. Standards Requirements for Generalized B and Type D Extractions

Method	Standards Needed	Best for Fixtures
Generalized B	Open Open/Short	Well-matched fixtures with very well-matched inner plane. Reflection-only standards possible
Existing D	Thru	Well-matched fixtures with very well-matched inner plane. Thru-line standard possible
Multi-standard D	2 lines Line + (Open OR Short)	Moderately-matched fixtures without structural assumptions other than symmetry. At least one line standard possible.
Phased-localized D	Line Or (Open OR Short)	Moderately mismatched fixture assuming most mismatch not at inner plane. No symmetry necessary. One standard only

7-9 Sequential Extraction—Peeling (with Option 24)

Another method of network extraction involves modeling the network as a collection of lumped elements. This is particularly popular for electrically small structures (e.g., on-wafer) or those with runs of transmission line punctuated by electrically small structures (e.g., PC boards with isolated vias in transmission lines).

Procedurally, this method works on one lumped element at a time. For each element, a .s2p file is generated that can be de-embedded to allow one to get at the next element. Also transmission line segments can be separately de-embedded to get between lumped defect areas. The process is based on reflection measurements only and a full calibration incorporating that port must be in force.

The basic method accepts as input the location (in time from the reference plane) of the defect area of interest and the type of element to model the structure: shunt admittance (Y) or series impedance (Z). A 0 can also be entered as the position and, in that case, an automatic calculation will be performed to select the largest remaining defect. A differential pair can also be selected in which case the model element is a crossbar impedance (between the two ports) and a .s4p file will be generated. The dialog is shown in [Figure 7-31](#).

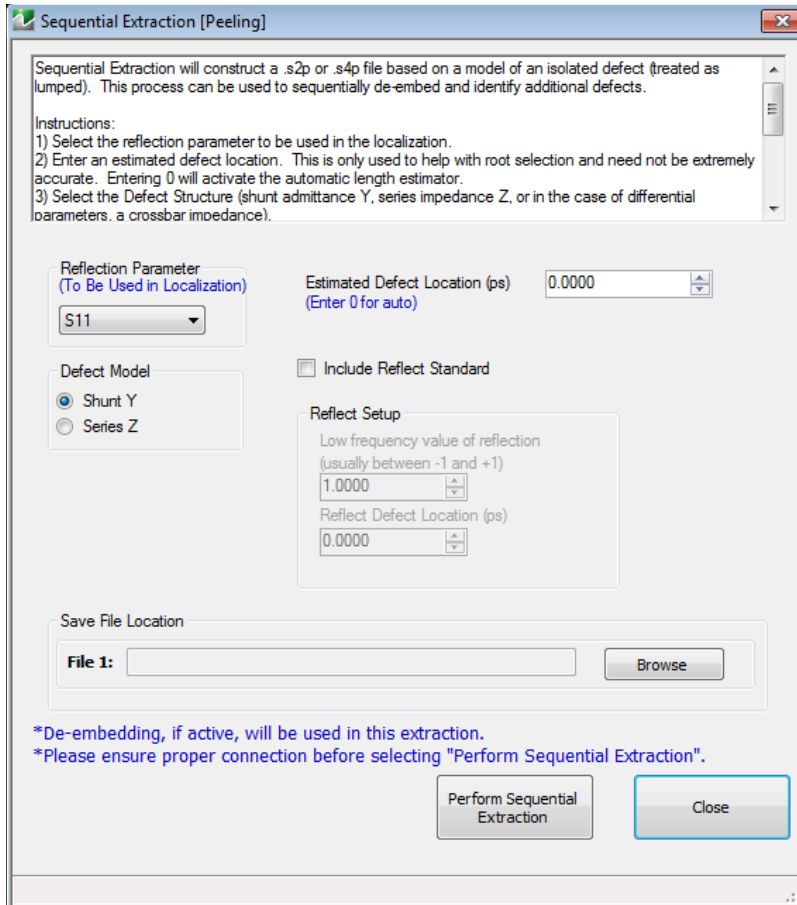
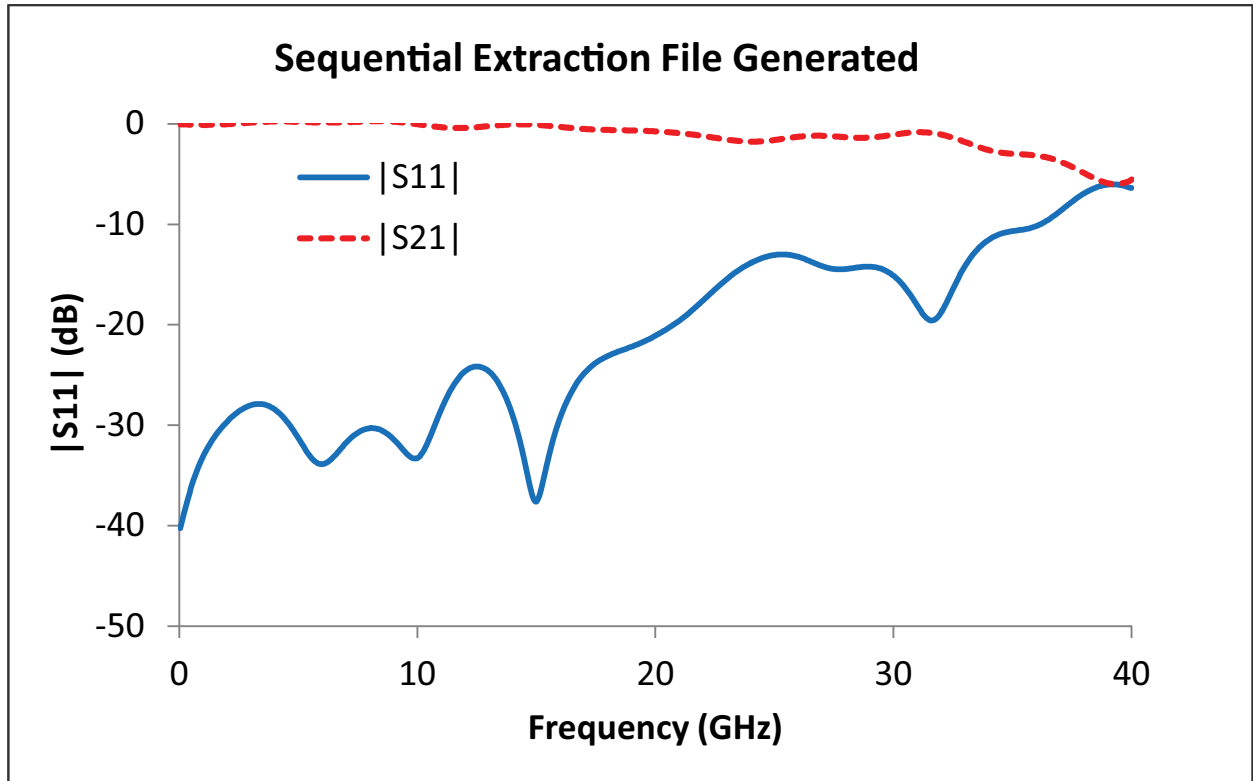

Figure 7-31. Sequential Extraction Dialog

As an example, consider a fixture with multiple transitions but one is known to be particularly inductive (in a series sense). It might be interesting to look at the return loss of this fixture if that particular transition could be improved. It is known that this launch is about 120 ps in from the reference plane so the sequential extraction tool was used with that defect position entry and a Z-series element selection. A 2-port calibration had already been performed. The extracted .s2p file for the element shows the result in Figure 7-32. As might be expected, the return loss of the model element is indeed degrading with frequency and the insertion loss increases.



Values from the series network extracted for the example fixture are plotted here.

Figure 7-32. Sequential Extraction Plot

To remove this from the fixture result, two steps are needed: de-embed the 120 ps (air equivalent 36 mm) of transmission line and de-embed the file just generated. This was done and the before and after de-embedding results are shown in Figure 7-33. Indeed, the inductive transition was responsible for a fairly large share of the overall fixture mismatch and improving that one transition could have significant benefits. The final result is not perfect since there are additional transitions in the fixture but also because this extraction is somewhat model-like: it is only valid if the defect is indeed series in nature (or shunt if the admittance version had been selected). In this particular case, the series model was a very reasonable choice.

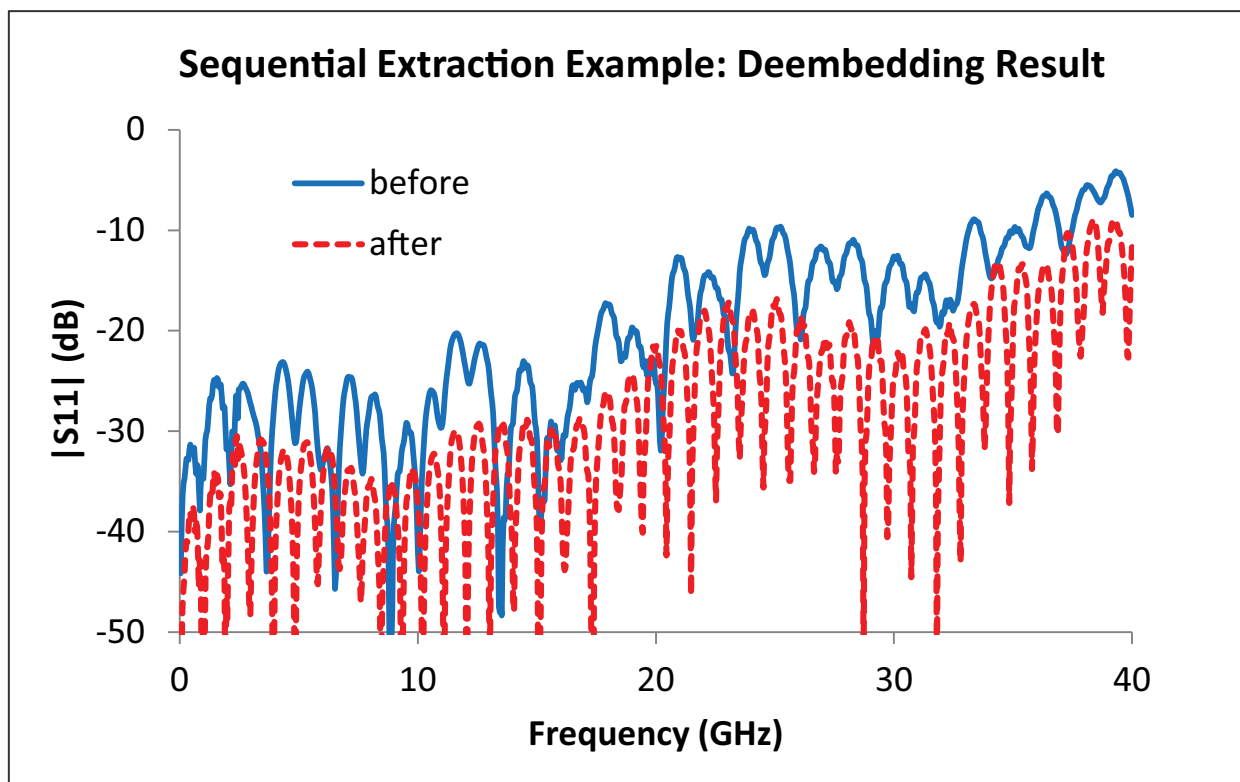

The before and after de-embedding return loss values of the example fixture are shown here.

Figure 7-33. Sequential Extraction Example—Deembedding Result Comparison

The basic method is adequate for electrically small structures but inaccuracies can enter the picture if there are un-de-embedded losses between the reference plane and the defect center. An extension to this method can help compensate for these losses by using analysis of another, known reflection center. If there is a known reflection at the end of the fixture (e.g., an open or a short), the analysis of that response can be used to compute a loss estimate and correct the extraction of a lumped element representing a defect between the reference plane and the reflection standard. The reflection coefficient of the standard must be entered (must be real and normally between -1 and $+1$) and its position relative to the reference plane is usually entered. A zero (0) can be entered for the location and an automatic routine will be used to locate the largest response which is presumed to be due to the reflection standard. If an auto routine (0 entry) is also used for the defect location, the next larger response (distance less than that of the reflect standard) will be used for that item.

To see the effect of the reflect standard, consider the effort to extract the .s2p file for a via structure in a transmission line. The defect is located ~ 170 ps in from the reference plane but the transmission line is of fairly high loss. It is possible to place an open reflect standard at about 400 ps from the reference plane and that open is electromagnetically well-behaved at least to 40 GHz (our range of interest). The via structure will be modeled as a series impedance and the simple sequential extraction produces a file with the return loss shown as the solid curve in Figure 7-34. If one also uses the reflect standard (position 400 ps, reflection coefficient = $+1$), one gets the dashed line instead. Ignoring the line loss up until the defect would have caused one to underestimate the defect return loss by nearly 10 dB at 40 GHz.

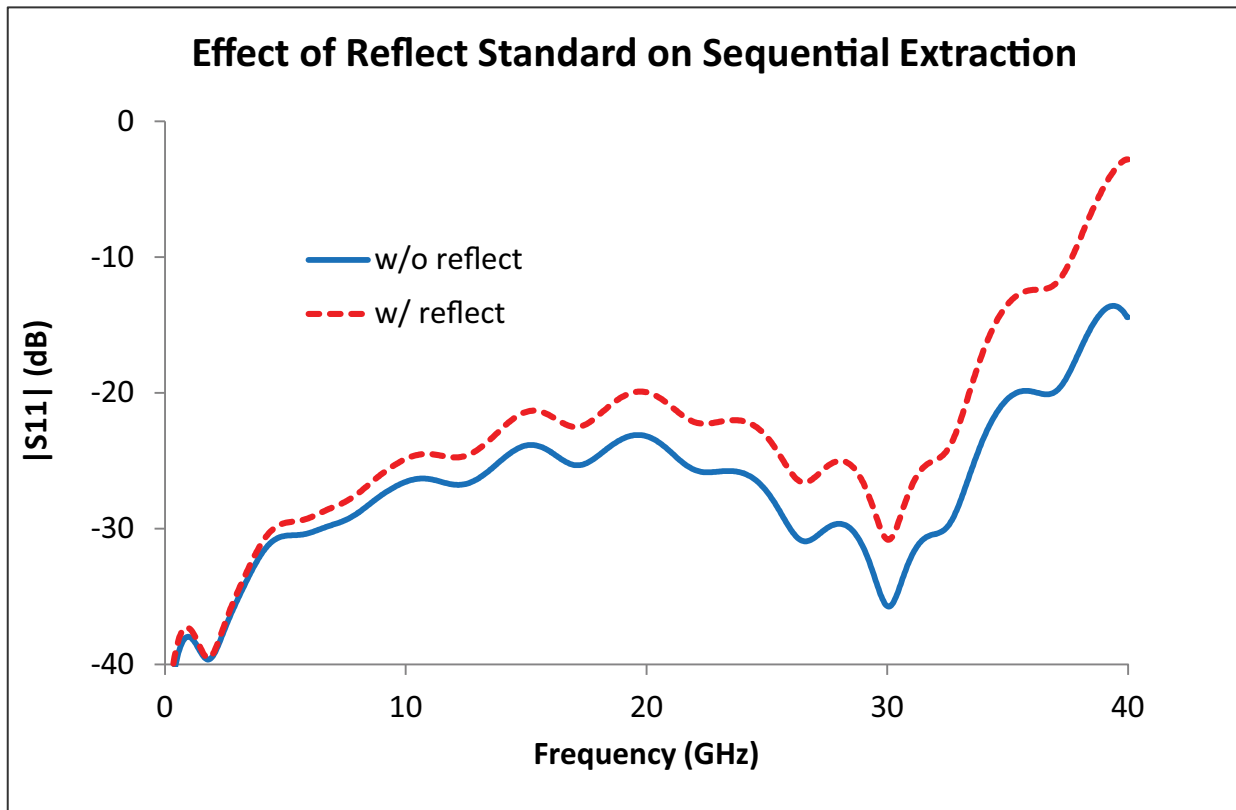

As shown with this example, using the reflect standard to compensate for line loss can be useful if the defect is far from the reference plane in a lossy medium.

Figure 7-34. Sequential Extraction—Effect of Reflect Standard

7-10 Uncertainty and Sensitivity

The selection of a network extraction method is heavily dependent on the standards that are available at the inner plane and the results can vary wildly depending on the quality of and knowledge about those standards. While we cannot be complete in this guide in a discussion on uncertainties and sensitivities, we can give some general thoughts. Many publications exist on the topic that may provide more information, such as *J. Martens, "Common adapter/fixture extraction techniques: sensitivities to calibration anomalies, 74th ARFTG Conf. Dig., Dec. 2009*, and references therein.

The Type C extraction is, in some sense, the most complete since it uses all of the error terms in two full-port calibrations to extract the S-parameters of the individual fixture arms. For that reason, Type C is also the most sensitive to standards quality at the inner plane. Uncertainties will follow those of the underlying calibrations quite closely, subject to a repeatability penalty associated with the two calibrations.

Type A is a bit different in that there is only one fixture arm, but it does still use two full-term calibrations. The computation difference is that it does not use transmission or load match terms to calculate the adapter/fixture S-parameters and hence is more immune to problems with those calibration steps than is Type C. Even if there is a problem with a reflect standard, Type A may be less sensitive since the reflect errors propagate to load match in the standard calibrations (particularly true for reciprocal methods). As an example, a mismatched pad was evaluated using both Type A extraction and an SOLR calibration, but a perturbation was introduced in one of the reflect calibration standards. As shown in [Figure 7-35](#), the sensitivity with Type A (labeled AR for adapter removal) is lower. The comment 'one-sided-distortion' is included in the plot since symmetric errors in a Type A setup tend to cancel (another advantage in some cases), so the introduced error was made on only one side in this measurement to create a worst-case result. Each trace in the plots represents a different assumed reflect magnitude value for the standard (over a 10 % interval).

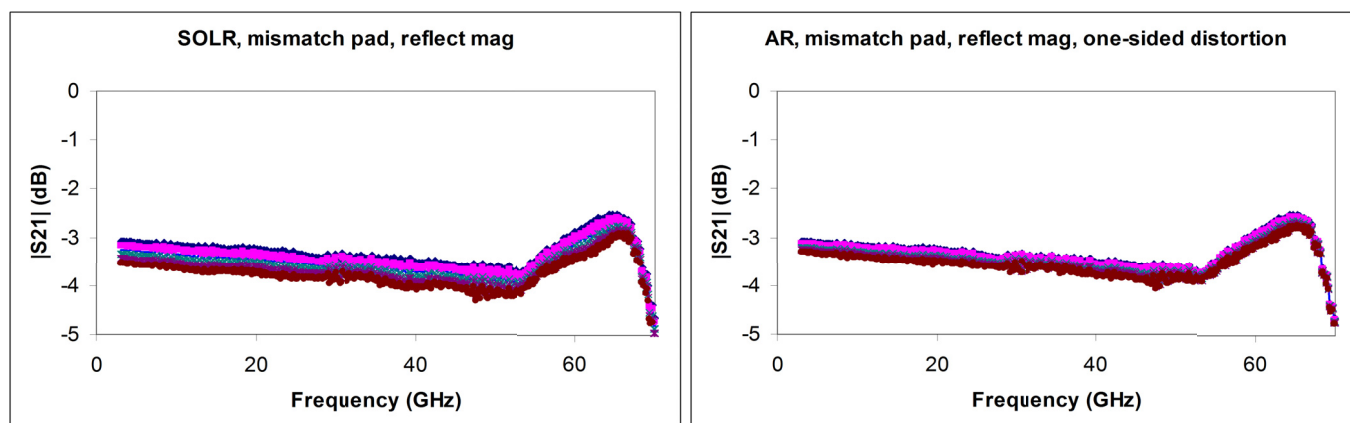

Figure 7-35. Comparison of Reflected Standard Problem for Type A Extraction and SOLR Calibration.

A comparison of the effects of a reflect standard problem on the transmission of an example DUT are shown here for both type A extraction (AR, adapter removal) and a SOLR calibration. The various traces represent the result with different assumed reflect standard offset lengths.

Although less sensitive to some effects, it may not always be possible to do reasonable full port calibrations to support Type A. The Type B method requires only one port standards, which can be far more convenient. The internal computations are similar between Type A and Type B (in the full-standards case) except in how output match is determined. Type B is a more source match-intensive computation, so there is greater sensitivity to the high reflect standards' behavior with Type B than with Type A (and less dependence on low reflect behavior). A comparison is shown in [Figure 7-36](#) for Type A (again labeled AR for adapter removal) and Type B (labeled BP for Bauer-Penfield, two of the original authors to work on this method class). The sensitivity of output match to a reflect standard problem (a short in this case) is indeed greater. Again, each trace represents a different reflect magnitude value. Type B with flexible standards falls into the category of 'partial information methods' like Type D. With the partial information techniques, it is useful to distinguish between sensitivity to standards problems from absolute error (even if the standards were perfect). With network extraction methods A, B (in its full-standards form) and C, the absolute error is zero. Type B when using one or two standards allows one to accept some non-zero absolute error in exchange for reduced sensitivities to standards errors and repeatability. These sensitivities for Type B were discussed in the section describing "Type B Network Extraction".

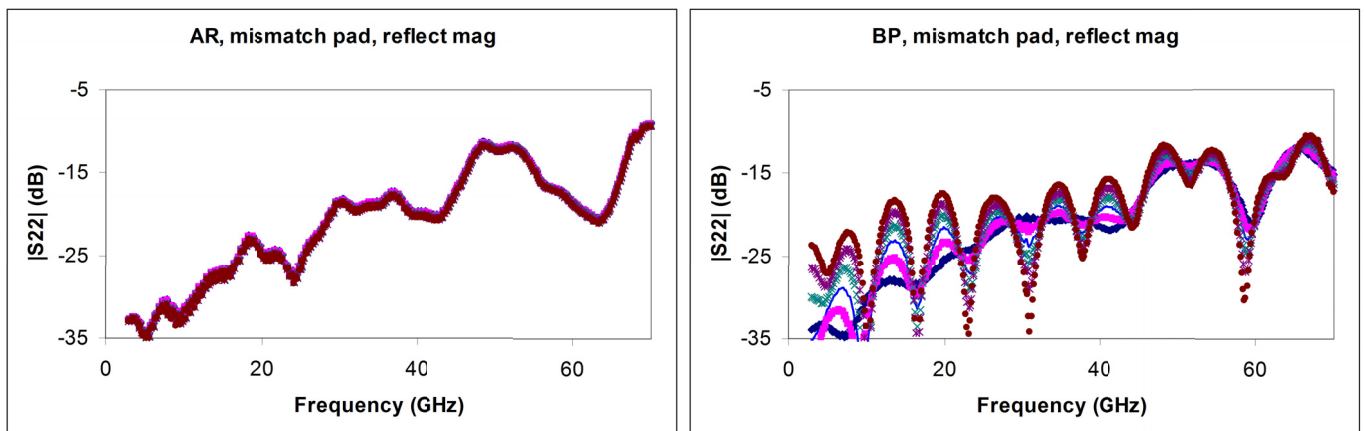

Figure 7-36. Comparison of Output Match Sensitivity for Type A (AR) and Type B (BP) Methods

Correspondingly, the load sensitivity is somewhat reduced, but it will have an impact on high RL adapters and high IL adapters, as suggested in [Figure 7-37](#).

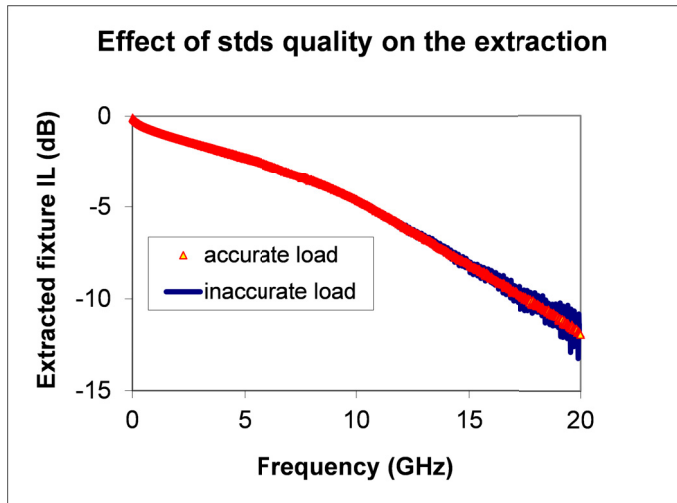

Figure 7-37. Effect of Load Standard Problem on Extracted Insertion Loss

The effect of a load standard problem on extracted insertion loss with Type B. Eventually, the load accuracy does matter.

Type D is another approach entirely and is appropriate when it is difficult to create any reasonable standards at the inner interface. Also, when repeatability is problematic (for example, spring contacts, poorly positioned probes, etc.) trying to achieve knowledge of fewer parameters can be useful. The concept is to reduce weight on the inner plane match and/or make additional structural assumptions and focus on improving the accuracy of the insertion loss extraction. The absolute accuracy will be degraded from what one could get from either of the other methods (if good standards were available), but repeatability sensitivity can be greatly improved and the net practical uncertainty can actually be better. This follows from the $1/(1-x)$ kind of behavior of match terms in the standard methods. If the measurements are not terribly repeatable and the 'x' term is moving near unity, the uncertainty on the final parameter in practical terms can balloon. One can see this in a wafer probing example where probe placement was not that accurate. A series of calibrations were done using SOLR and using Type D extraction with a single thru (labeled partial information in Figure 7-38). The removal of match dependence lowered the scatter in the final insertion loss values. While repeatability sensitivity is better, there is sensitivity to inner plane match and to problems with the underlying calibration at the outer planes (although reduced).

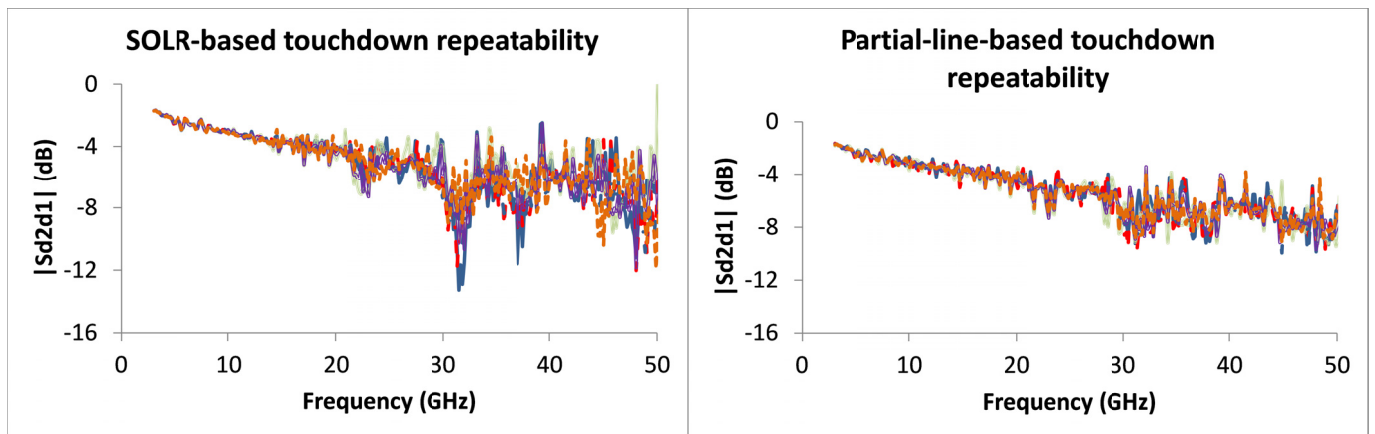

Figure 7-38. Comparison of Repeatability Effects

A comparison of repeatability effects is shown here for two methods (standard calibration and Type D) when that repeatability was not good.

While repeatability sensitivity is better, there is sensitivity to inner plane match and to problems with the underlying calibration at the outer planes (although reduced).

The effect of an inner plane distortion is shown in [Figure 7-39](#). The effects can be substantial, but the errors in this particular example would have exceeded 4 dB with a Type C methodology because the media was pin-based and not repeatable.

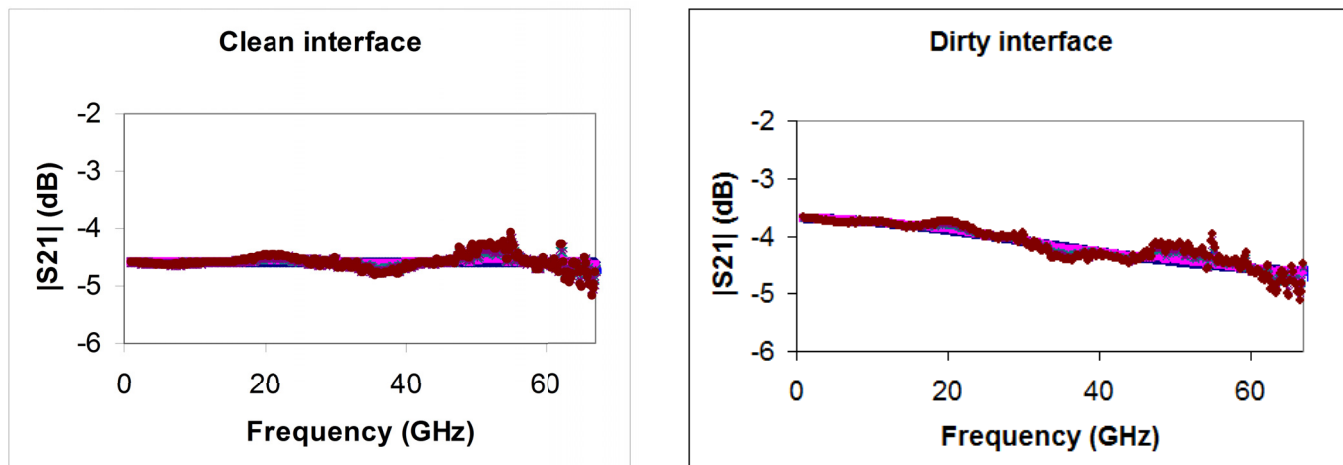

Figure 7-39. Sensitivities of a Type D Extraction to Underlying Calibration Issues

The sensitivities of a Type D extraction to underlying calibration issues (multiple traces per plot, reflect magnitude variations) and introduction of an inner plane match and position problem (the dirty interface plot).

Some of the Type D sensitivities were covered in the previous section. As with the one- and two-standards variants of Type B, Type D allows one to accept some non-zero absolute error in exchange for reduced sensitivities to standards errors and repeatability. Within Type D, there are a number of choices depending on which standards are available. If a thru is available and the fixture halves are relatively symmetric, phase localized D with a thru standard can do very well unless the fixture is very mismatched at the inner plane. Multi-standard variations of D (using two lines or a line and a reflect) can take over in the latter case. If only a reflect standard is available, reflect-based phase-localized D will usually outperform Type B with one standard.

The various extraction methods discussed here present a variety of choices dependent on standards quality, the media involved, and the possible measurement repeatability. In some sense it is a continuum (C->A->B->D) of choices more appropriate as the environment becomes decreasingly metrology-friendly. This is an oversimplification, but some of the sensitivities presented may help in making a good choice for a given measurement setup.

7-11 Enforced Passivity and Causality

When S-parameter data from network extraction or just from measurement are used in external simulators, there are sometimes requirements on the data in terms of passivity or causality for simulation convergence or for other performance requirements. It is possible to enforce these characteristics on .sNp saved data (either measurement or network extraction) although changes are made to the data in that process. This section will discuss the enforcement procedures and some of the implications. [Figure 7-40](#) shows the sNp setup dialog for enforcing Passivity and Causality, which can be accessed via:

Main | System | Setup | Misc Setup | SnP Files Setup | SNP SETUP dialog

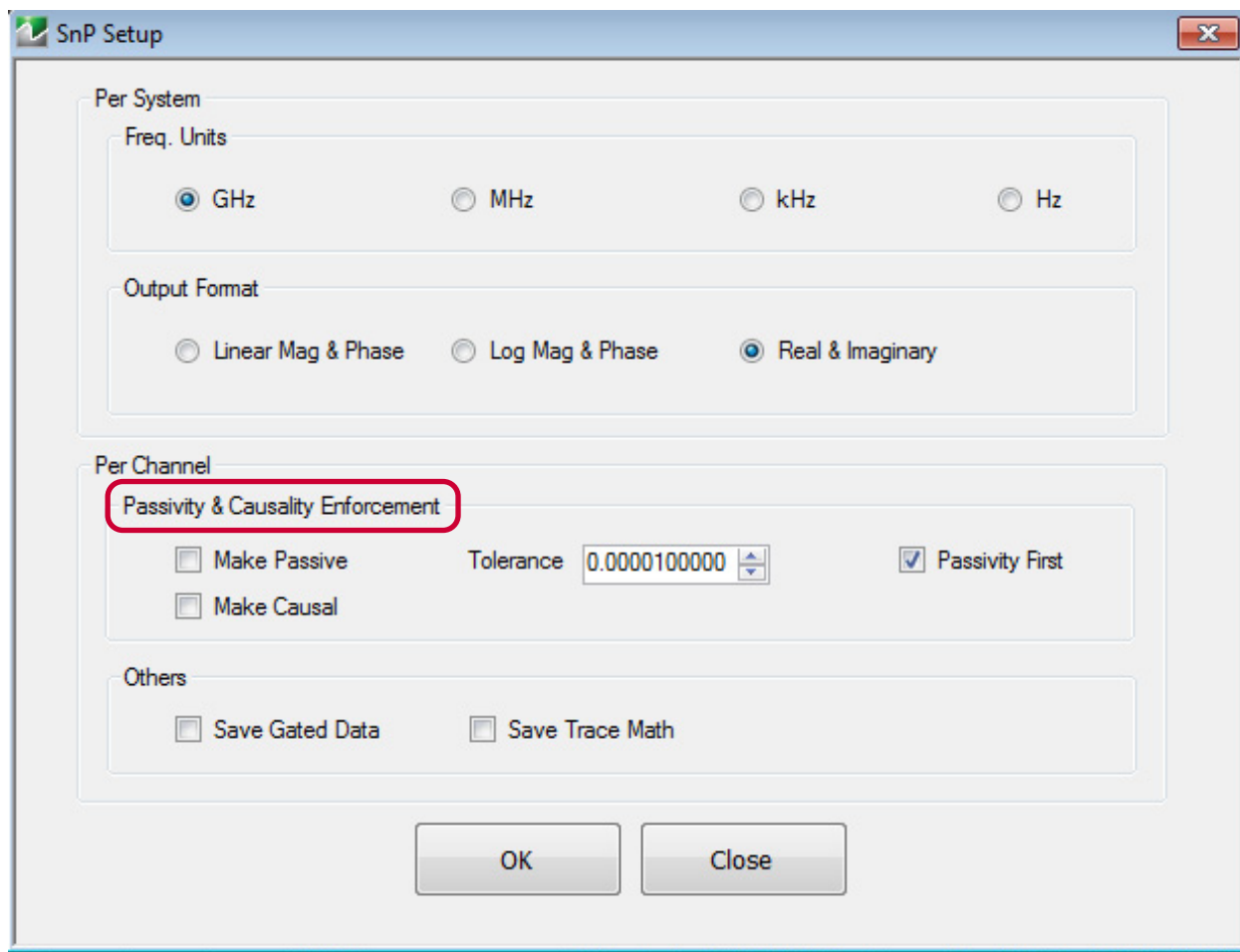

Figure 7-40. SnP Setup Dialog

Passivity

Here, this is defined as the 2-norm of the S-parameter matrix being less than or equal to one. This is equivalent to the eigenvalues of the S-parameter matrix all being less than or equal to one in magnitude. The reader may associate passivity with $|S_{21}| \leq 1$ but that is not a sufficient requirement for most situations where convergence is an issue.

In practice, many passivity violations (on actually passive devices; those not capable of energy conversion) arise from calibration problems (standards issues), cable or drift issues, or repeatability variances (connections or probe touchdowns). Ideally, those issues should be addressed to improve the basic data quality. However, for very low loss devices/fixtures, the data may only be marginally non-passive and it may be expedient to coerce that data to proceed with a simulation, system design, etc. The **Make Passive** selection will do this on all .snp saves but it is up to the user to assess if the changes being made to the data are acceptable.

Typically the changes are quite small if the calibration quality is good. As an example, the measurement of an adapter chain is shown in Figure 7-41 and the passivity-enforced result is overlaid on top (aside: as stated elsewhere, this can be done by placing the instrument in Hold and recalling the .s2p file that was saved (with passivity enforcement in this case); the actual measured data was saved to trace memory). One can see some slight changes under 2 GHz where the insertion loss is the lowest. The 'enforced' insertion loss at very low frequencies is increased by ~0.005 dB and the return loss is increased by about 1 dB at the -40 dB level. This level of change is far below the uncertainty levels and is likely to be acceptable.

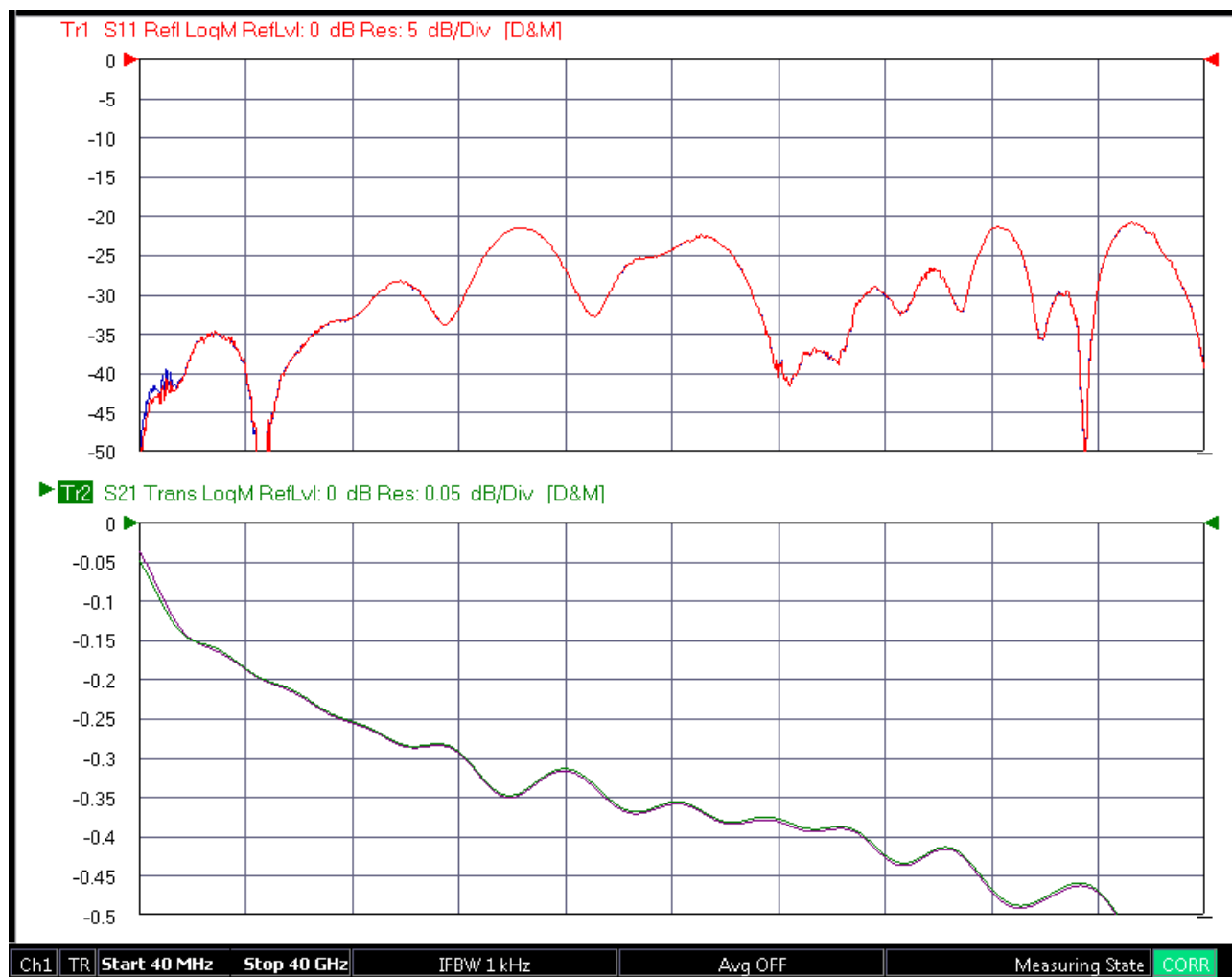

Figure 7-41. Measurement of an Adapter Chain and an Enforced-passivity Version of that Data

The measurement of an adapter chain and an enforced-passivity version of that data are shown here overlaid. There is only a difference at very low frequencies.

If the calibration quality is poor, the changes can be more dramatic. To simulate this, a non-existent transmission line was de-embedded from the original calibration so insertion loss reads artificially low (and indeed shows insertion gain for the adapter chain at low frequency). The change from passivity enforcement in this case exceeds 0.1 dB at low frequencies and is noticeable at higher frequencies (see Figure 7-42). This happens because the introduced calibration degradation also caused apparent mismatch levels to be much higher. This is important since now the 2-norm can exceed unity even if $|S_{21}|$ is ~ 0.4 dB. The changes made in enforcement here are significant and, if they occurred with a real calibration, one might want to investigate the calibration and measurement (cables, connectors, standards, etc.) before continuing with the enforced data.

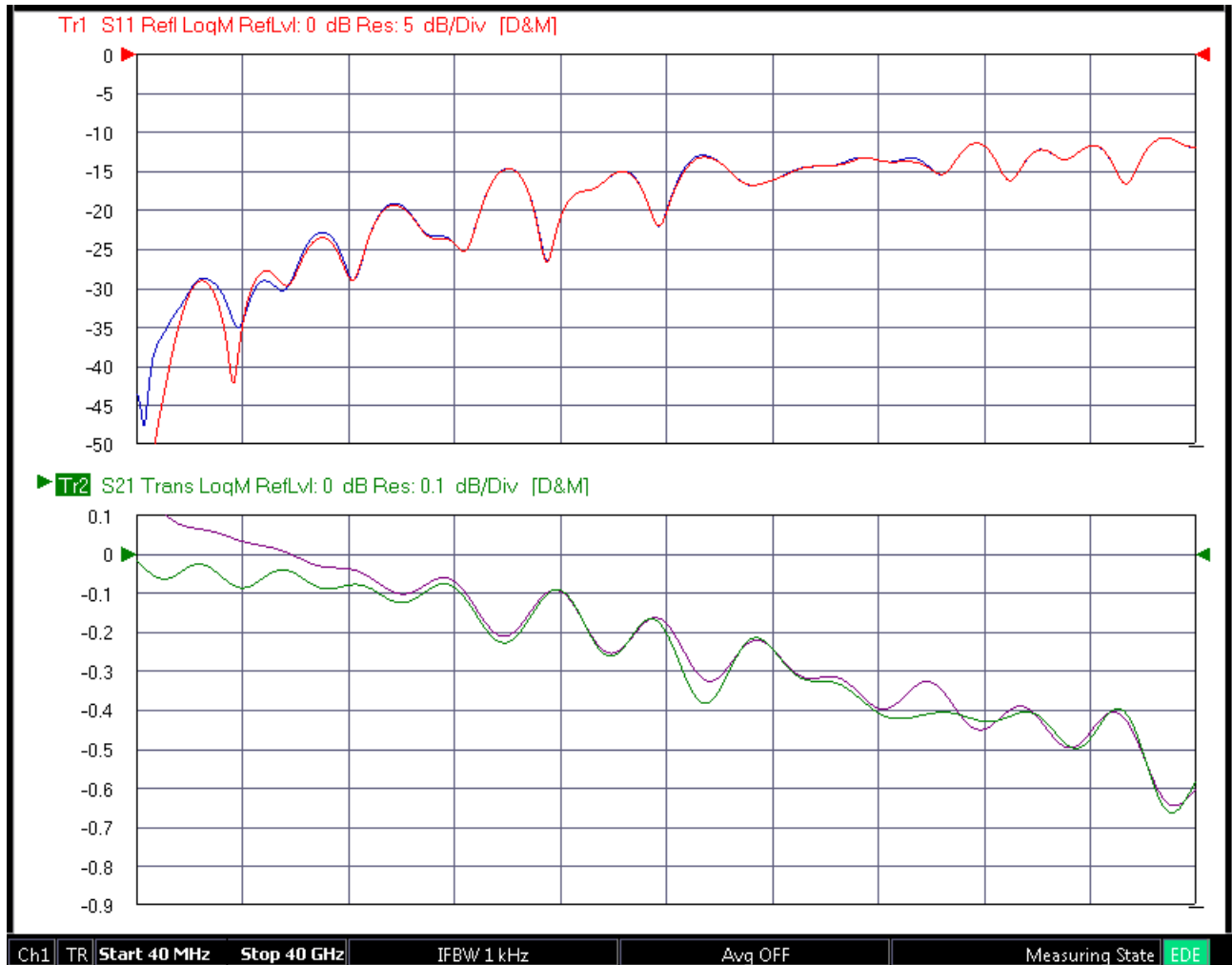

Figure 7-42. Passivity Enforcement with Calibration Problems

With calibration problems (actual ones or those introduced artificially like in this example), the passivity enforcement can have more dramatic effects.

The passivity enforcement works by re-scaling the eigenvalues of the S-parameter matrix in a self-consistent way and then regenerating the S-parameters from the new eigenvalues. The consistency of this approach is important since one wants to maintain the relationship between reflection and transmission parameters as much as possible to lessen the effect on any other system calculations.

The user is given some control over how much less than unity the 2-norm must be since some simulators screen for passivity using tests that are more-or-less stringent. A 'tolerance' variable is provided and if the entry is x , the maximum eigenvalue magnitude will be $1-\sqrt{x}$. The default value for x is 0.00001 and is allowed to go as high as 0.001 for the more stringent tests.

Causality

Causality is the state of not being dependent on the given parameter value at an earlier point in time. This has a number of implications:

- The time domain representation should have no energy before time $t=0$ (assuming the reference planes have not been shifted and are in a physical location).
- Often it implies the parameter is analytic on the upper half of the complex plane. This conclusion does require that the parameter falls off fast enough with frequency along with a few other conditions.
 - This in turn implies that Kramers-Kronig relations apply. Importantly, this means that the real and imaginary parts (or, equivalently, the magnitude and phase) of the parameter are not independent.

As with passivity, this condition may be required of S-parameter data that is to be used in certain simulations and, again, there is a way to coerce data to make this happen. In practice, causality violations can occur from calibration and drift issues (particularly nonlinear phase drift) and from measurements of very broadband devices with a small measurement bandwidth (so there is little roll-off). This last statement follows from the observation that any limited bandwidth set of data, when transformed to the time domain, will have energy for $t < 0$. This energy becomes significant if there is little parameter roll-off at the highest measurement frequency. Thus, using more measurement bandwidth can help, up until the point where DUT or fixture radiative behaviors make the data unstable.

The corrections in this category also tend to be small and they are largest often at the higher frequencies. The plot in [Figure 7-43](#) shows the vector difference of S21 between original and enforced data on a mismatched line of modest insertion loss (~ 8 dB at 50 GHz and 50 GHz of measurement bandwidth). The change is not visible on the magnitude of S21 in this example but the alteration can be seen in phase [Figure 7-44](#) as the distortions in phase have more of an effect on the temporal distribution of energy.

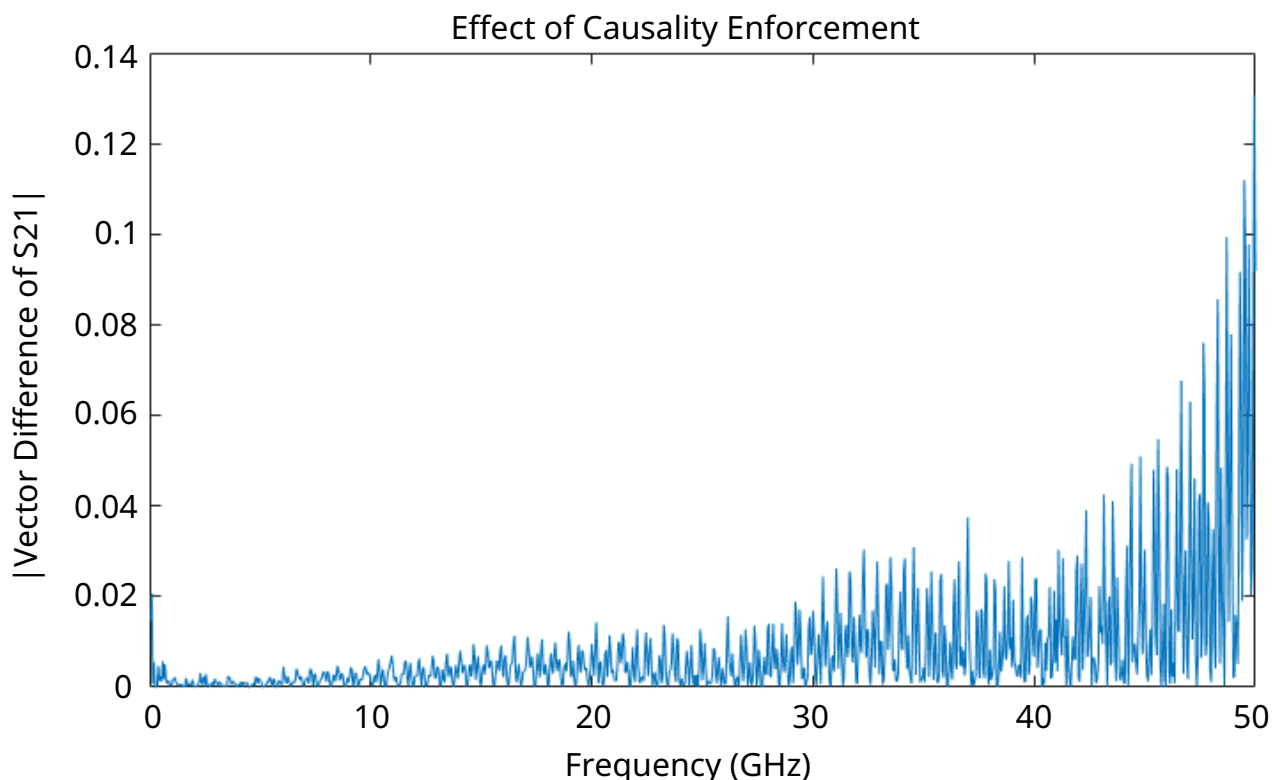

Figure 7-43. Vector Difference Caused by Causality Enforcement

The vector difference caused by causality enforcement is plotted here. The corrections are often largest at the higher frequencies.

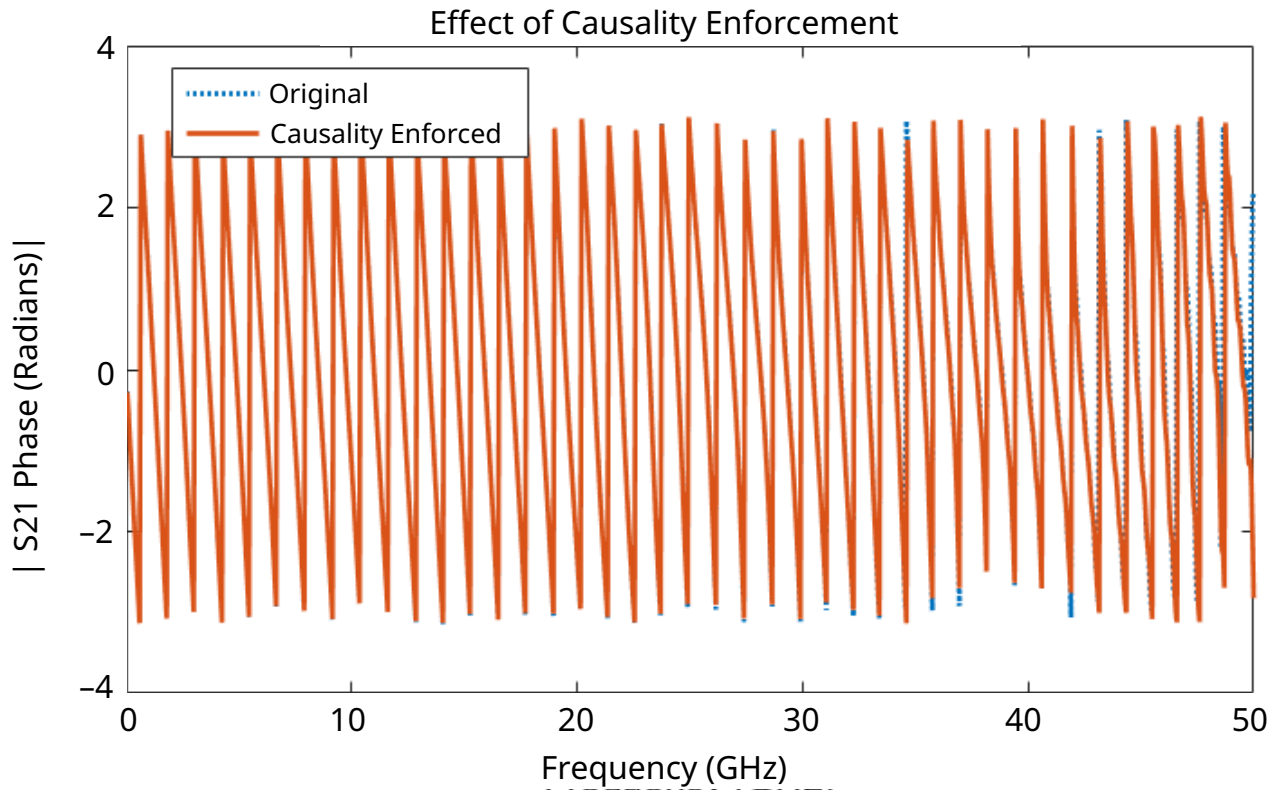

Figure 7-44. Actual S21 Phase Data With and Without Causality Enforcement

The actual S21 phase data (with and without causality enforcement) is plotted here for the example. The vector difference in S21 was shown in [Figure 7-43](#).

The enforcement process starts by coercing the imaginary part to have the desired relationship to the real part (there is some flexibility on what is a ‘fixed’ property that we will return to). To have zero energy before $t=0$, the time domain (impulse) function must have an odd part that will cancel the even part correctly:

$$g_{odd}(t) = \text{sgn}(t) \bullet g_{even}(t)$$

So

$$g(t) = g_{even}(t) + \text{sgn}(t) \bullet g_{even}(t)$$

$$G(f) = F\{g_{even}(t)\} + F\{\text{sgn}(t) \bullet g_{even}(t)\}$$

$$G(f) = G_{even}(f) - jH_{even}(f)$$

Equation 7-2.

Where H_{even} denotes the Hilbert transform has been applied (the Fourier transform of a time function with the sign function applied is a working definition).

Now, another conclusion of causality is that the negative frequency components of the response are the conjugates of the corresponding positive frequency components. This implies that the real part of the frequency response is exactly the even portion. Thus the enforced result is simply related to the Hilbert transform of the real part of the data.

From an energy conversation point-of-view, it may be preferable to keep the magnitude of the parameter fixed instead of the real part and this is presented as the default configuration. This fixing of the magnitude is easy to accomplish since we can simply scale the result above by a real function (normalizing magnitude).

As in passivity enforcement, the coercion process does change the data so if the changes are large, it is generally advised to look into possible measurement execution issues (use a VNA with wider bandwidth, calibration components or method choice, cable drift, connection repeatability, etc.) to see if the measurement could be improved instead.

7-12 Summary

A series of techniques have been presented for handling and studying the problem of non-insertable DUTs. Adapter removal is a 2-calibration technique for removing the effects of an adapter from a given calibration setup (e.g., when the DUT has one coax port and one waveguide port). Network extraction is somewhat more separable in that it tries to extract the S-parameters of the complicating adapter/fixture so that it can be de-embedded later. Several different types of extraction (with a number of sub-types with different standards or with localization techniques) were presented with various trade-offs in calibration complexity, simplicity, and uncertainty. A modeling-based extraction technique using sequential localization or peeling was also presented.

Although not specifically part of network extraction, sometimes trace math (**Data, Memory Math** on the **Display | View Trace** menu) is used for normalization and other forms of pseudo-de-embedding. The ability to save memory data is covered elsewhere in this guide, but an additional tool to help is the ability to save math-modified data to .sNp files. This selection is available in the sNp Setup dialog (see **System | Setup | Misc Setup | SNP Files Setup**). When Save Trace Math is selected and one or more traces have trace math turned on, the modified data for the parameters with math applied will be saved to the .sNp file. This can be useful for saving normalized results. If trace math is not applied for every parameter (which would only happen for a .s4p file if 16 traces were active and all had trace math applied and each trace had a different S-parameter), the unmodified data for the uncovered parameters will be saved instead.

Chapter 8 — Other Calibration Procedures

8-1 Overview of Other Calibration Procedures

This chapter provides other calibration procedures not covered in the previous material. Thru Update, Interpolation, and Hybrid Cal are discussed.

8-2 Through (Thru) Update

A common question related to calibrations is how often the calibration must be redone. The frequency of re-calibration depends on the environment (both in terms of temperature stability and in terms of the cable/fixtures construct that is being used). A calibration lifetime is often limited by the stability of the test port cables through drift or motion. Drift defects directly affect transmission tracking and load match, so if those terms could be easily refreshed, the time before the entire calibration had to be redone could be extended. This is the concept of a Thru Update.

The idea is to connect just a through line and quickly refresh the transmission tracking and load match terms without great effort. A Thru Update is a one-step calibration that can be used to refresh a current full 2-Port or 1 path-2 port calibration.

Like the thru step in other calibrations, the length of the line being used as well as its loss can be specified to ensure minimal disruption of the reference planes (see [Figure 8-1](#)). The entry methods for these parameters are the same as in the normal calibration procedures.

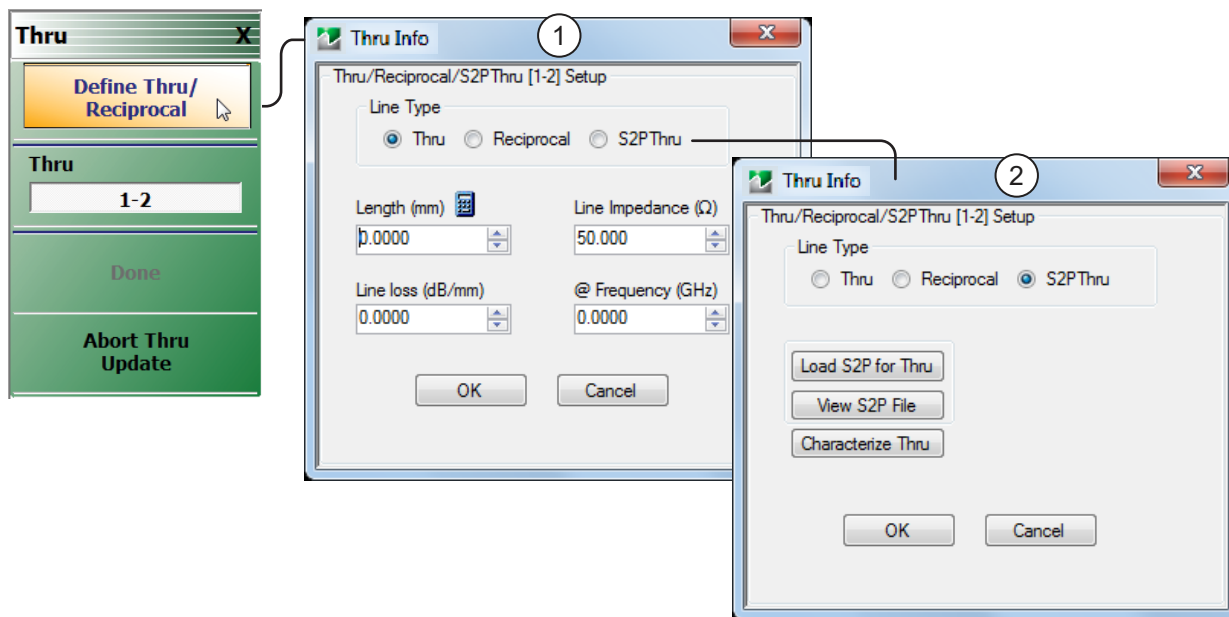

1. Through Line selected allows user entries for length, line impedance, line loss and frequency.
2. S2P Thru selected provides buttons for loading, viewing, and characterization (to generate S2P files).

Figure 8-1. THRU UPDATE Setup Menu and THRU INFO Dialog

8-3 Interpolation

Typically, calibration is done for a specific list of frequencies and then measurements are made over that same list of frequencies. While this is most accurate, it is not necessarily convenient. If, for example, one is measuring a variety of narrow bandpass filters of different center frequencies, it may be useful to be able to zoom in to look at the passband of each filter without re-calibrating. Interpolated calibrations are allowed for purposes like this one. The theory is that the error coefficients are all carefully interpolated between calibration points to minimize possible error.

To see the cause of error, note that the cable runs within the instrument and the cables that the user provides typically result in a large electrical length. Thus the error coefficient magnitude versus frequency is often periodic in shape. If the interpolation is not performed with care, large errors can result (see [Figure 8-2](#)).

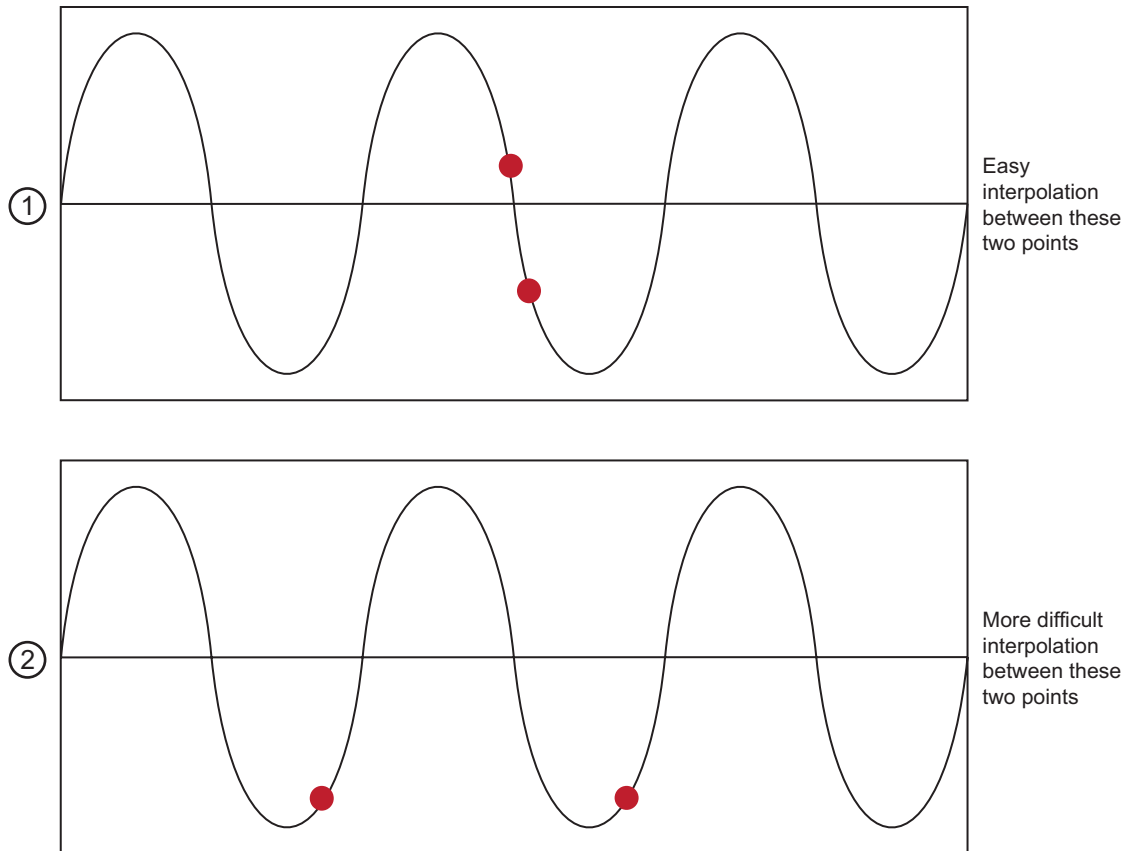

Step size, interpolation effects, and possible errors.

1. Easy interpolation between these two points.

2. More difficult interpolation between these two points.

Figure 8-2. Effect of Step Size on Interpolation

As a general rule, the smaller the step size used during the calibration, the more successful the interpolation will be. It is desirable to keep the step size smaller than the ripple period of the coefficients, which will typically range from 50 MHz to 500 MHz. The smaller number is for setups with very long test port cables and fully optioned systems. The menu to select interpolation is shown below in [Figure 8-3](#).

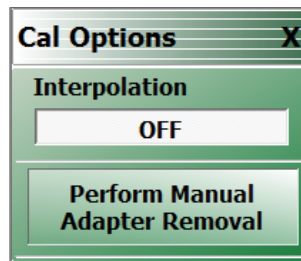

Figure 8-3. CAL OPTIONS Menu

The calibration interpolation menu will default to OFF where points used during measurement must correspond to calibration frequency points. When interpolation is ON, other points may be used. In neither case may frequencies outside of the calibration frequency range be used.

To gain a better understanding of the uncertainty implications of interpolation, it may be helpful to consider how the error terms of a typical calibration vary over frequency. A large scale and zoomed-in version of one parameter (source match) is shown in [Figure 8-4](#). Even with relatively low point densities, the large scale variation in the large-scale plot would be captured by interpolation. The fine scale variation shown in the zoomed-in plot is, however, another matter.

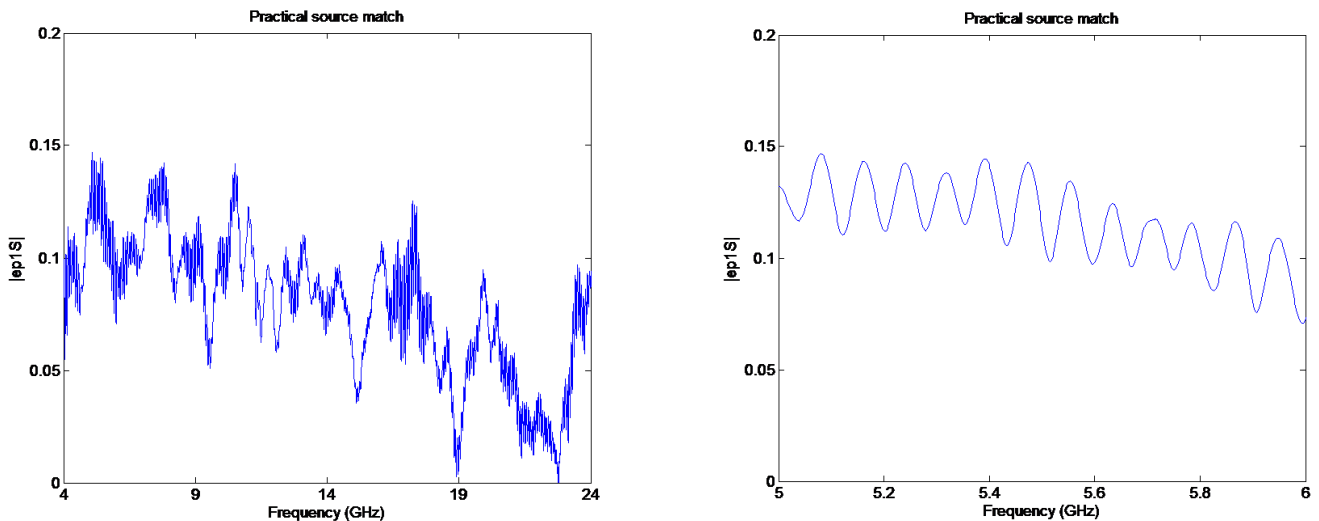

Figure 8-4. Large scale and zoomed-in source match variation over frequency.

Now, consider two different sets of hardware, both with a nominal tracking coefficient of unity (for simplicity). At lower frequencies, set 1 may be readily achieved, but at millimeter wave frequencies, set 2 may be more practical. The important point is that the interpolation effects are setup dependent.

- Set 1: Raw directivity ~ 0.02 (-34 dB) and raw source match ~ 0.1 (-20 dB)
- Set 2: Raw directivity ~ 0.10 (-20 dB) and raw source match ~ 0.3 (-10 dB)

If one calculated the uncertainties for no interpolation and for worst-case interpolation for both of these sets, one would get results like that shown in [Figure 8-5](#) (for a standard SOLT/SOLR coaxial calibration).

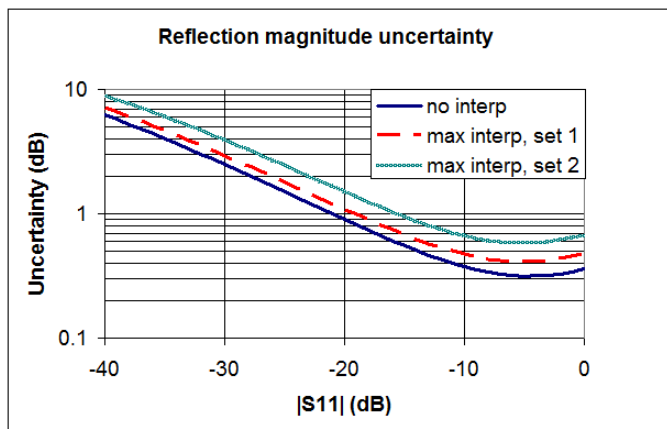

Figure 8-5. Uncertainty penalties possible with worst-case interpolation for some example setups.

As suggested above, one can get around this problem by increasing the frequency point density. In [Figure 8-6](#), the point count was increased so that there were 10 calibration points per period of the ripple (a proxy for the electrical length of the setup, much like that discussed in [Chapter 4](#)).

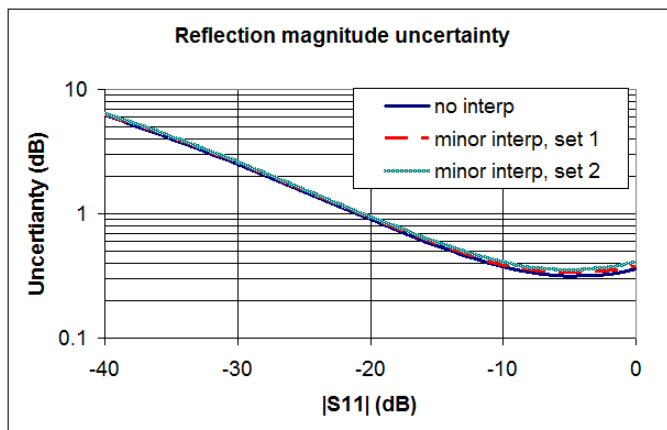

Figure 8-6. An increase in frequency point density can reduce interpolation effects in all setups, as would be expected.

8-4 Hybrid Calibrations

The hybrid calibration is a method of taking a pair of distinct 1-Port calibrations, together with some additional measurements, to create a new full 2-Port calibration. The “*hybrid*” part of the definition comes in that the two 1-Port calibrations may be with completely different connector types, media types, and/or cal algorithms. One example may be a case where it is desired to have Port 1 in coax but Port 2 in waveguide. This is conceptually similar to some of the adapter removal and network extraction discussions in [Chapter 8](#), but here a little more flexibility is offered on the calibration side. In particular, the through completion step may be a reciprocal device only (thus bringing in SOLR concepts).

Generally the two 1-Port cals are performed in advance and the setups saved, typically as an active channel CHX file type. One enters the dialog below and specifies those cal files. Then the “*through*” between the two ports is specified using the usual THRU INFO dialog format. In the case of a physical through, length and loss information is specified. In the case of a reciprocal, a length estimate is requested to simplify root choice.

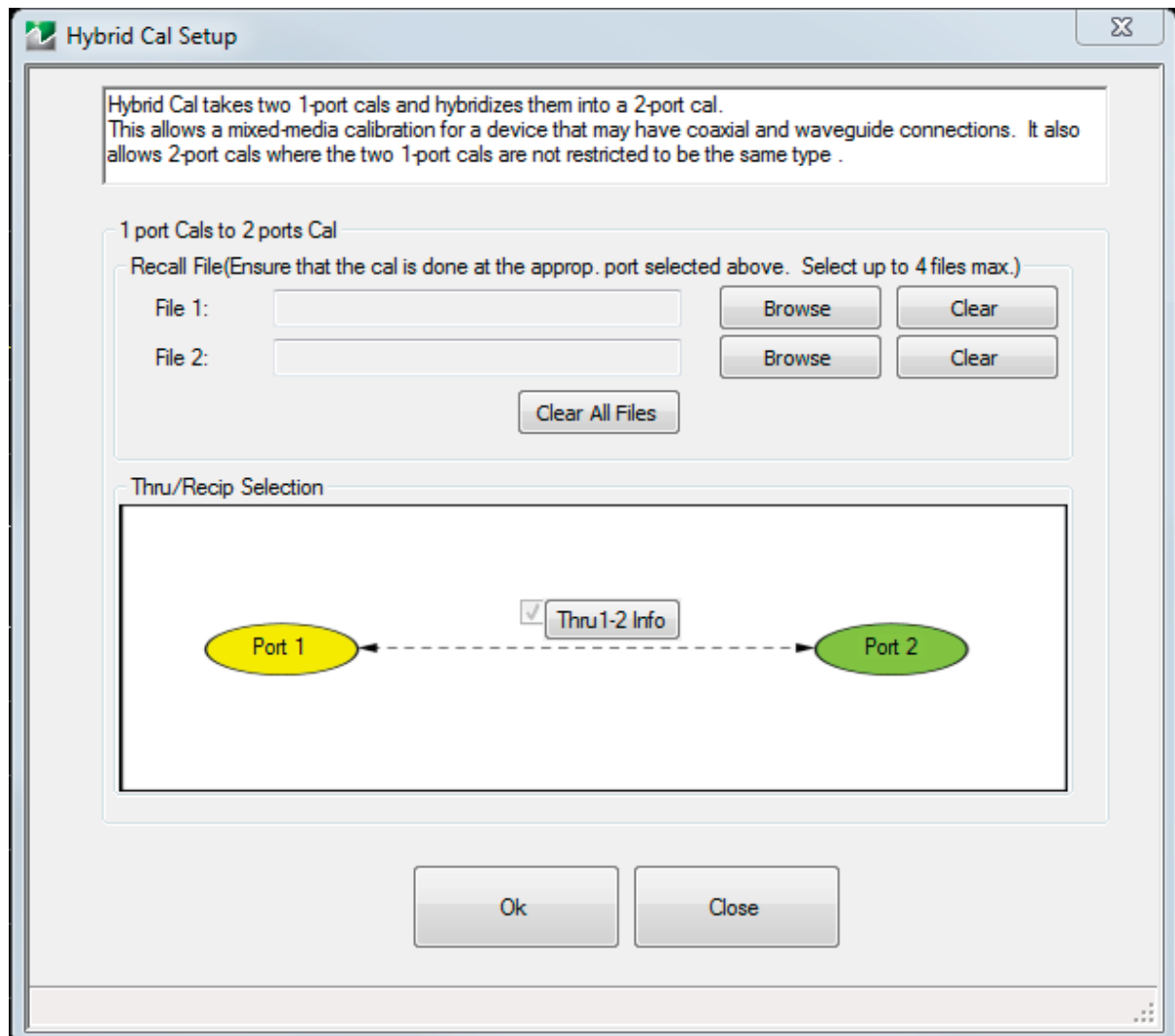

Figure 8-7. HYBRID CAL SETUP Dialog Box

As with the adapter removal and network extraction procedures, the cal files used here must be based on the same frequency lists (same frequency range and same number of points at least). In this case, the files must both describe full 1 port calibrations.

As an example of the mixed-media case where this type of hybrid calibration is helpful, consider a desired coaxial-waveguide combination reference plane. One could perform adapter removal processing as discussed in [Chapter 8](#), but there are occasions where in one of the media planes, one can only perform one port calibrations (due to physical arrangement of the hardware, calibration kit availability, or other reasons). For this example (in WR-42 waveguide), a one-port K calibration was done for one file and a one-port WR-42 waveguide calibration was done for the other file. These two files were combined using the hybrid calibration dialog and the resulting calibration was used to measure the hybrid device of [Figure 8-8](#). Note that this figure refers to a port 1-3 calibration associated with multipoint measurements, but the algorithm is exactly the same for two port systems.

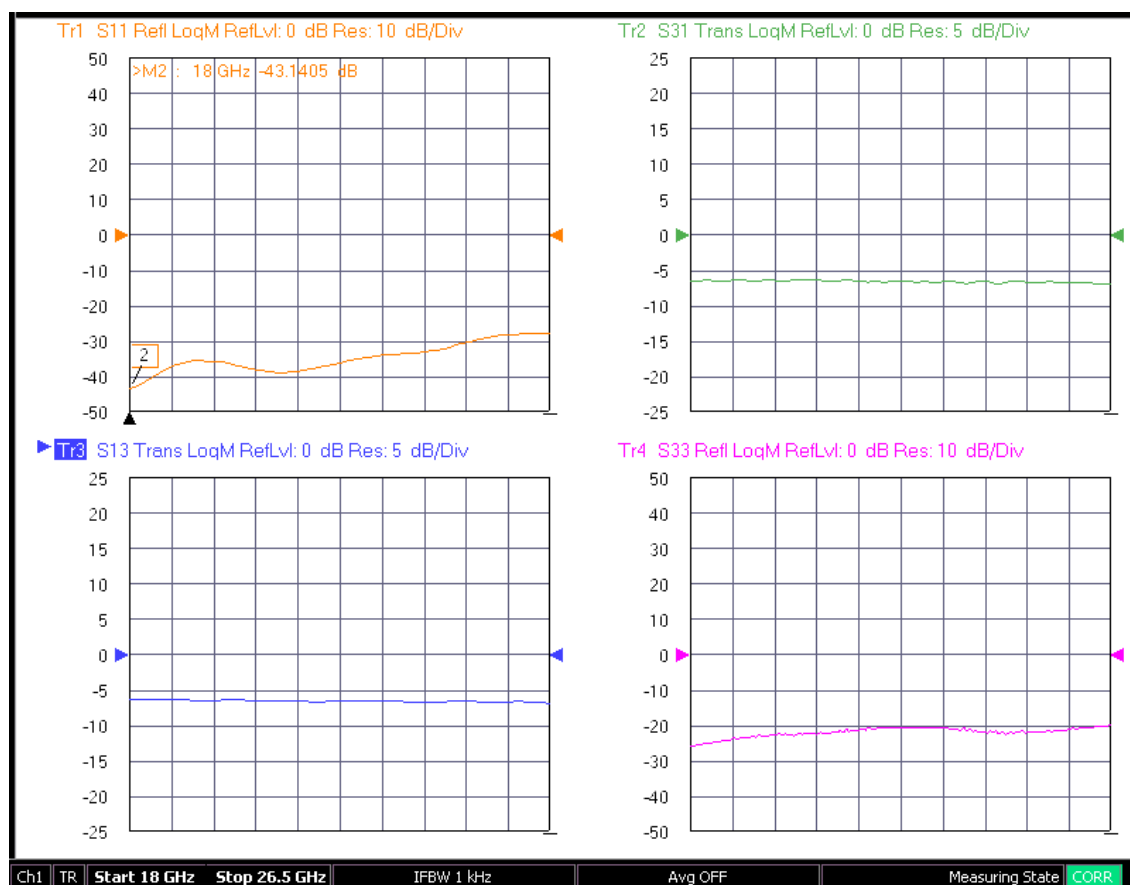

Figure 8-8. Example hybrid waveguide-coaxial measurement that was enabled by the hybrid calibration dialog.

8-5 Secondary Match Correction

Secondary match correction (SMC) is about improving measurement performance and reducing uncertainties mainly for measurements of very low insertion loss devices. At the frequency of interest, if the DUT loss is more than a few dB, this function will usually not have significant impact but it can offer improvements when DUT losses are smaller than that. Since the function slows down sweep updating, it is turned off by default. The function can be employed after any calibration (excluding reflection-only calibrations) is applied. This section will explore the SMC process and how it can be useful in a number of measurement applications.

Suppose one is measuring a very low loss device (a precision adapter for example). One may get an insertion loss plot like the below when using a precision calibration kit in good condition. One may wonder about the ripple in the data in [Figure 8-9](#). It is only about 0.05 dB peak at worst, which is well below the measurement uncertainty of ~0.1 dB to 0.12 dB (peak) for this particular measurement, but it still may be undesirable. One may notice that residual error terms are on the order of 30 dB to 35 dB and the DUT match may be on the order of 25 dB so one could even rationalize that multiple reflections between those (effective) interfaces may explain the result.

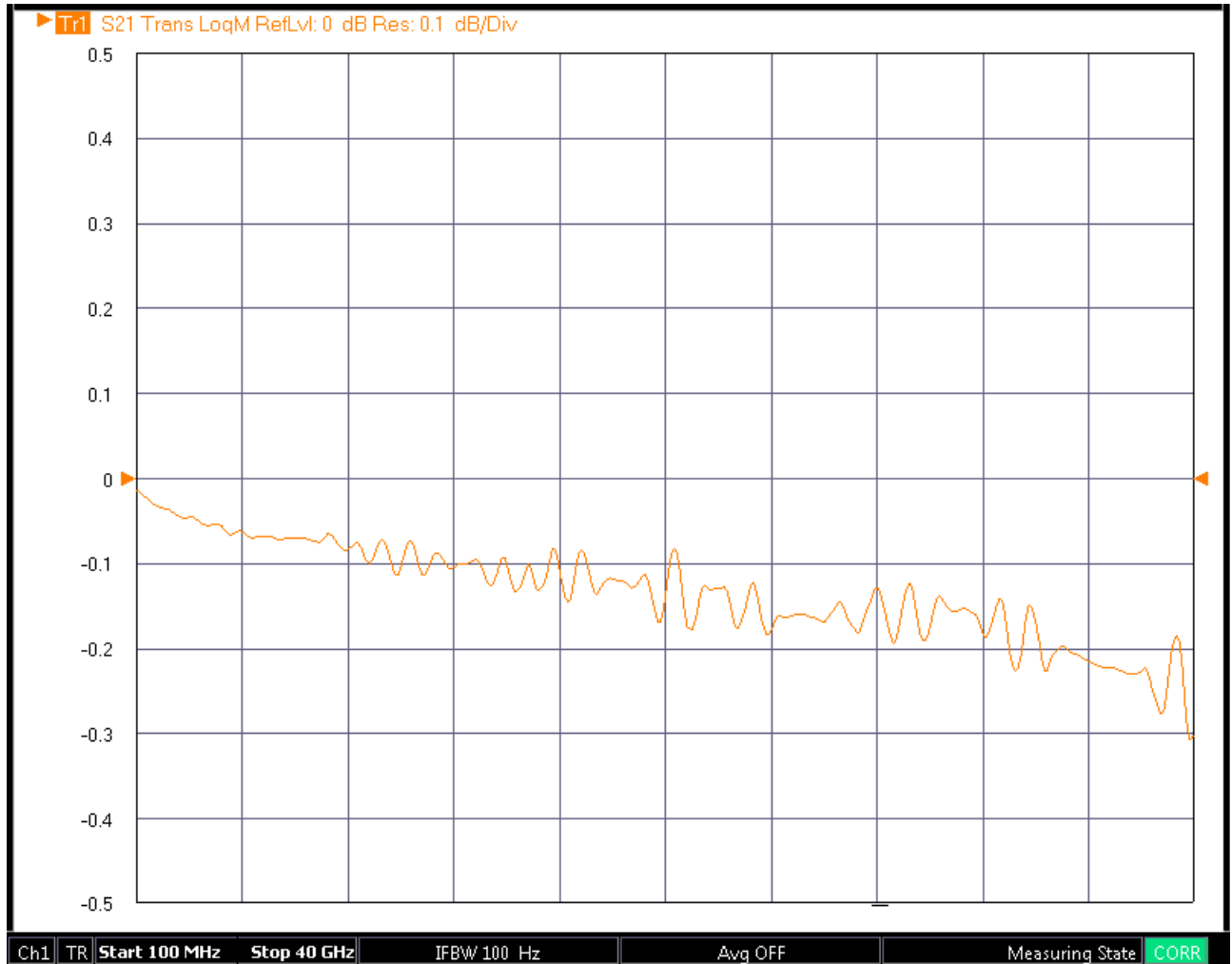
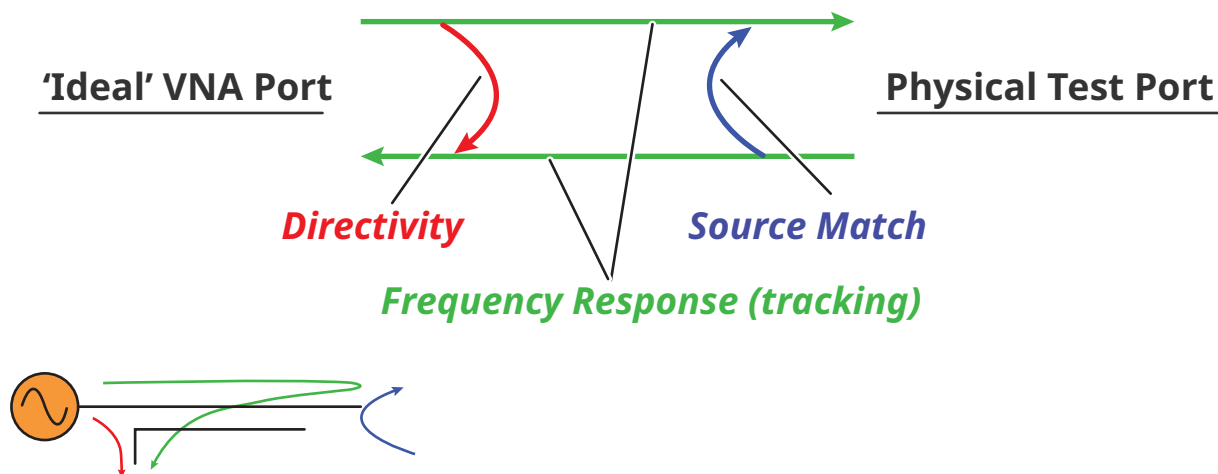

Figure 8-9. Example: Low Insertion Loss Measurement

Some of this ripple can arise from high DUT reflections, from pin depth issues in the mating reference planes or with the DUT (or with the calibration kit!), or there may be other explanations. One source of that ripple, however, can be a residual effect related to how match is corrected in the basic VNA calibration. In other chapters of this guide, the basic VNA error model was discussed and part of it is the simple reflectometer structure which is shown in [Figure 8-10](#).



The simple reflectometer error model is sketched here along with the mapped effects to a physical reflectometer.

Figure 8-10. Reflectometer Error Model

The error model arose from actual defects that occur in a physical reflectometer: finite directivity of a coupling structure, finite match of the coupler and nearby components, and a non-flat frequency response of the signal chain. Of particular interest to this discussion is match and, like with all models, how it is treated here is something of a simplification. Consider a slightly more complete model diagram in [Figure 8-12 on page 8-9](#). Suppose the dominant source of actual mismatch is at position Y in the figure. When the signal propagates from the source, some energy is reflected back to the source and some is transmitted. Of the portion transmitted, some reflects off of the DUT and then re-reflects off of Y. The product of those reflections ($\sim \text{eps} \cdot S_{11}$ where eps is the source match term in the calibration terminology discussed earlier in this guide and S_{11} is the reflection coefficient of the DUT) is important since the product repeats on multiple re-reflections, forming a geometric series. Thus when one looks at the basic reflectometer equation, the tell-tale result of an infinite geometric series is present in the denominator.

$$S_{11}^m = ed + \frac{et \cdot S_{11}^{act}}{1 - \text{eps} \cdot S_{11}^{act}}$$

Figure 8-11. Basic Reflectometer Equation

Here S_{11}^{act} is the actual reflection coefficient of the DUT and the 'm' superscript on the left side denotes 'measured'. Port 1 was used for this equation but any port could have been employed. In the case of Y being dominant, everything works out since the test coupler sees all of the multiple reflections and the actual measurement is very close to what the simple error model would arrive at.

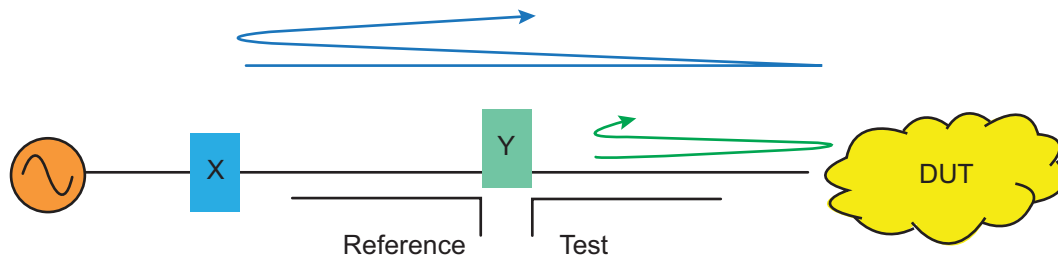

An expanded sketch of the reflectometer is illustrated here.

Figure 8-12. Reflectometer Expanded Model

Something different can happen if a significant reflection occurs at X. Now the reference coupler sees the mismatch as does the test coupler so the ratio that forms S_{11} , test/reference, sees a distorted picture of the reflection product and the reflectometer equation is really not as simple as that shown above. The test coupler will indeed see the effective series of reflections but the reference coupler sees some of it as well and the ratioing produces a partial cancellation or amplification depending on phasing.

The significance of these X and Y reflection locations can vary greatly from setup to setup but there are cases where the X location is non-negligible. It should be emphasized that these effects are smaller than quoted uncertainties as the uncertainty component evaluation process is also affected by the above mechanism. It should also be mentioned that this represents a fairly small perturbation on the effective port match so would not be visible on higher DUT loss measurements (more than a few dB) and, even for low loss DUTs, is generally only visible on a fine scale.

One could add additional calibration standards to solve for this more elaborate match model but this would lengthen the calibration process. One can also use the phase information in the calibration residuals to localize where the mismatch elements are. This is the principle behind secondary match correction: use the residual phase information to process a 2nd tier correction that primarily impacts the match terms.

Applying this to our previous example of the adapter measurement, one can see a significant reduction in the ripple ([Figure 8-13 on page 8-10](#)) that was not part of the DUT behavior after all (lighter trace is with SMC applied).

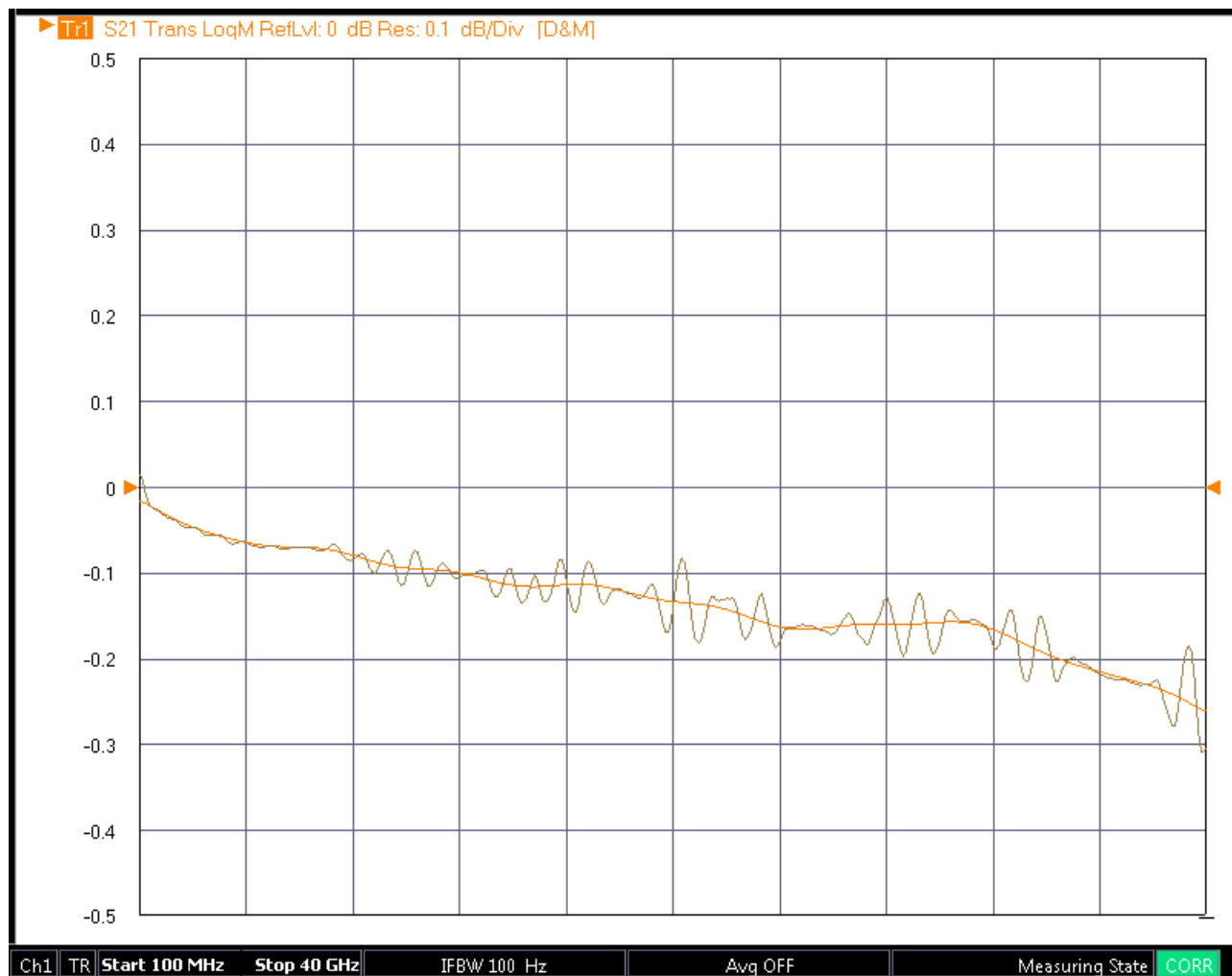

An adapter insertion loss measurement without SMC (darker trace) and with SMC (lighter trace)

Figure 8-13. Adapter Insertion Loss Measurement – Without/With SMC

A similar effect can be seen in the group delay measurement of the adapter (see [Figure 8-14 on page 8-11](#)). Although the effect is only a few ps of delay, it may be important in some applications such as careful delay-matching exercises or fine modulation distortion calculations based on measurements of a transceiver's group delay.

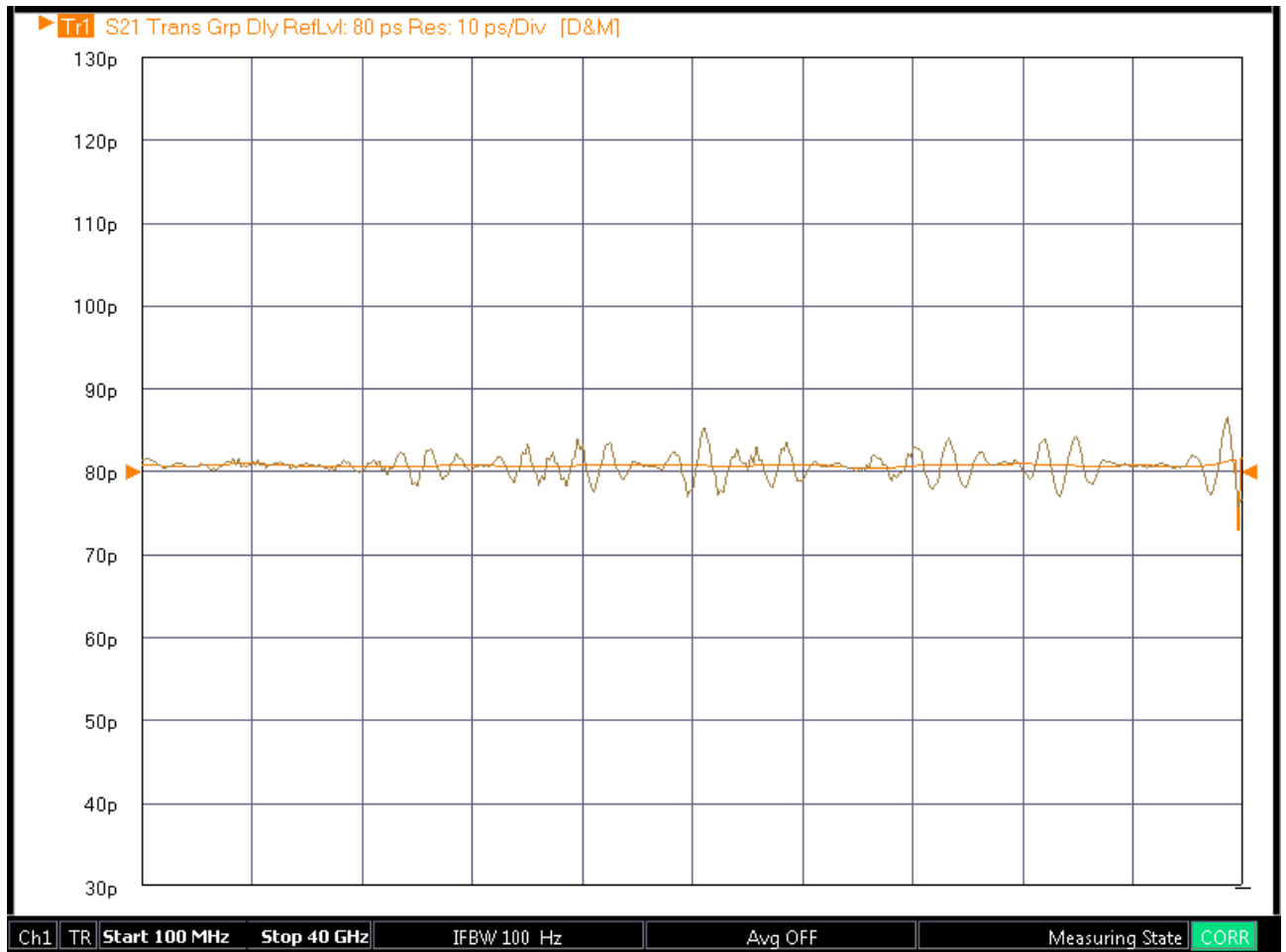

A group delay measurement of an adapter without SMC (darker trace) and with SMC (lighter trace).

Figure 8-14. Adapter Group Delay Measurement – Without/With SMC

Using secondary match correction only requires turning the selection ON under the CAL OPTIONS menu, as shown in Figure 8-15. Whenever an appropriate calibration is applied, then SMC will also be applied to the parameters. The appropriate calibration types include full 2-, 3-, and 4- port calibrations, transmission frequency response calibrations, and 1 path-2 port calibrations. SMC will not be applied to 1-port (reflection only) or reflection response calibrations. Since this is part of the correction engine, user-defined parameters (b2/1, b2/a1...) are not affected.

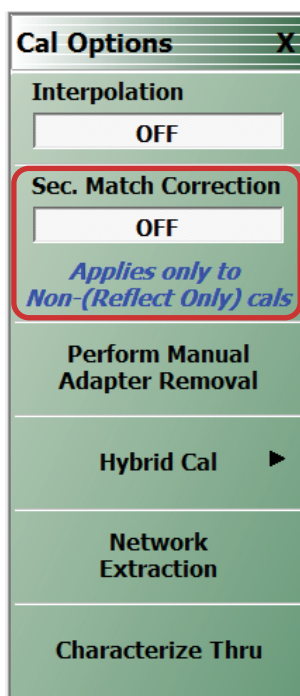

Figure 8-15. CAL OPTIONS Menu Showing Secondary Match Correction Button

There are few things to keep in mind about the behavior of this correction:

- If the frequency list is such that the phase residuals provide little information, then the correction will not be applied. This will happen if the step size is very large ($\sim >1$ GHz will limit the method's value) or if the frequency range is extremely small ($\sim < 2$ GHz will limit the value). In segmented sweeps with very irregular steps (step sizes deviating more than about 2% from the mean step size in the frequency list), the correction will not be applied.
- If extremely long test cables are used, the method may have less of an effect since mismatch is now concentrated in front of even the test coupler (which causes other issues with measurement stability anyway).
- If SMC is ON and one saves .sNp files, the SMC correction will be applied to relevant parameters. SMC will always flow through to .txt and .csv files.

In summary, the secondary match correction process allows one to optimize measurements of low insertion loss devices by correcting for a simplification made in the standard error model. The improvements are usually on the scale of hundredths of a dB in insertion loss and picoseconds in group delay but, particularly for low loss adapter and fixture characterization, those enhancements can be valuable.

Chapter 9 — Calibration and Measurement Enhancements

9-1 Chapter Overview

This chapter provides a description of functions that provide additional calibration, post-processing, and display options that increase the usefulness of the instrument data. The topics described include: embedding/de-embedding, reference-plane control and modification, and Impedance transformations.

These functions go beyond the basic calibration and display tools to help post-process the data in a way that is useful. The topics described relate to virtually modifying the environment in which the DUT resides.

- **Embedding/ De-embedding**

This is the virtual removal or insertion of networks or circuits around a DUT that may represent fixtures, launching structures, tuning elements, or other items.

- **Reference Plane Control**

This can be thought of as a simpler subset of de-embedding in which transmission line lengths and loss are removed from the measured data.

- **Impedance Transformation**

When calibration components are not available in impedances other than 50 ohms, it is possible to view the data as if the VNA had been calibrated in some other impedance.

In addition, there are some clerical tasks to describe including the order of virtual operations and some conversions to other parameter formats (impedances and admittances for example). The measurements menu that contains the majority of these functions is shown below (Figure 9-3, “Reference Plane Control” on page 9-12). Parameter conversions are a per-trace function (as opposed to the others which are per channel) and is listed under the DISPLAY menu.

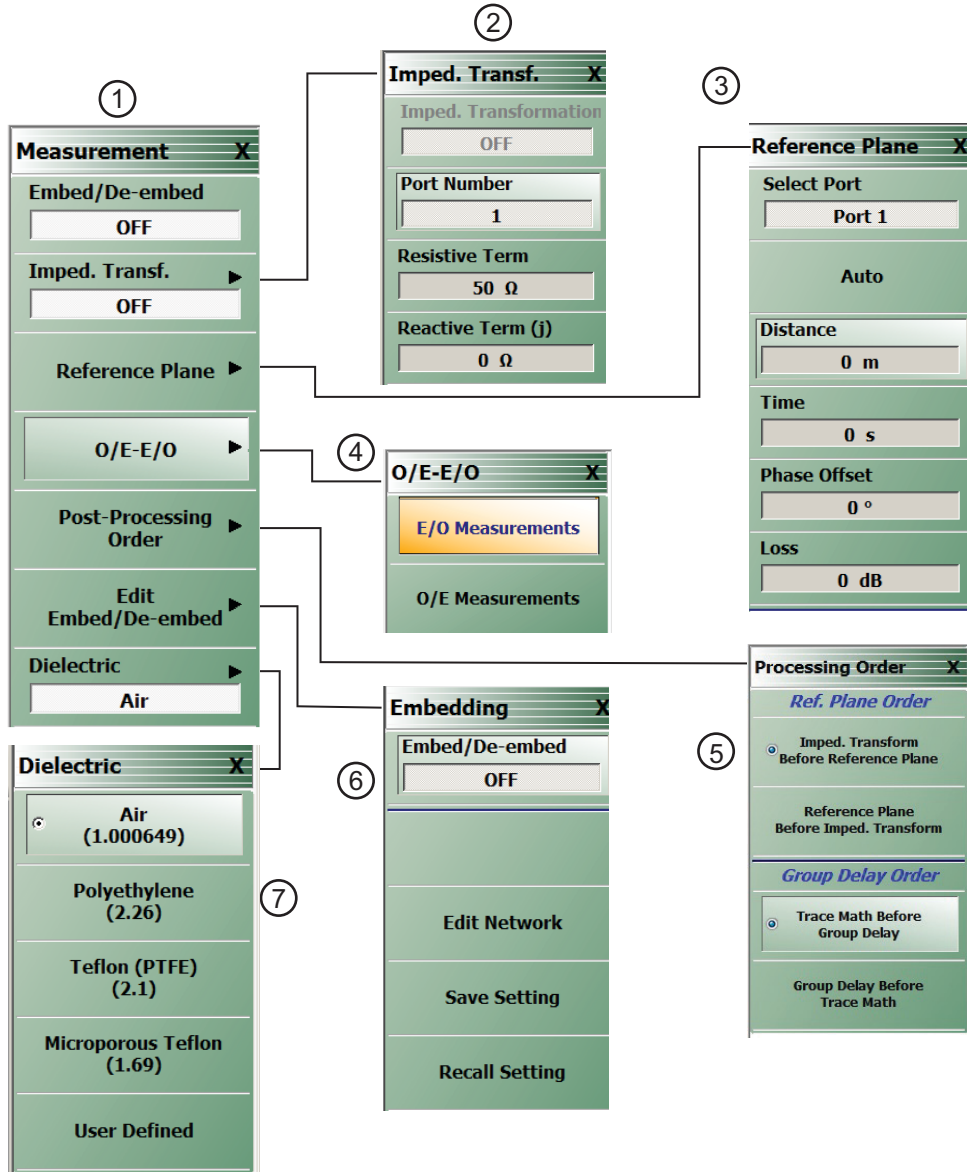

1. MEASUREMENT Menu	5. PROCESSING ORDER Menu
2. IMPED. TRANSF.(Impedance Transformation) Menu	6. EMBEDDING Menu
3. REFERENCE PLANE Adjustment Menu	7. DIELECTRIC Selection Menu – If User Defined is selected, Value field is available for input.
4. O/E–E/O Menu	

Figure 9-1. MEASUREMENT Menu and Related Submenus

9-2 Embedding/De-embedding (E/DE)

The MS46122A/B and MS46322A/B is equipped with an embedding/de-embedding system. De-embedding is generally used for removal of test fixture contributions, modeled networks, and other networks described by S-parameters (s2p files) from measurements. Similarly, the embedding function can be used to simulate matching circuits for optimizing amplifier designs or simply adding effects of a known structure to a measurement. Multiple networks can be embedded/de-embedded (E/DE) and changing the port and network orientations is handled easily. An extraction utility is part of this package that allows the easier computation of de-embedding files based on some additional calibration steps and measurements.

It is extremely valuable to be able to virtually remove or add networks to the measured data as described above. The process of adding network data to measured data is termed “*embedding*” while the process of removing network data is termed “*de-embedding*.”

Embedding Tasks

Common embedding tasks are to:

- View results as if a different launch structure was present
- View results as if a new matching circuit was being used
- View results as if an added cable length or transmission line length was needed

De-Embedding Tasks

Common de-embedding tasks are to:

- Remove the effects of a test fixture
- Remove the effects of a launch or launching transmission line
- Remove the effects of a test matching circuit that will later be physically removed

The MS46122A/B and MS46322A/B embedding/de-embedding engine (E/DE) is a flexible tool for performing tasks of this type. A number of different circuit element primitives are available and full S2P files can also be loaded.

Note

Circuit parameters for embedding-de-embedding network elements are stored in S2P files that can be loaded into the ShockLine VNA.

Embedding On/Off Control

E/DE can be turned on and off with the Embed/De-embed toggle button at the top of the main MEASUREMENT menu as shown above (Figure 9-1) or with a duplicate toggle button at the top of the EMBEDDING control menu as shown below (Figure 9-2).

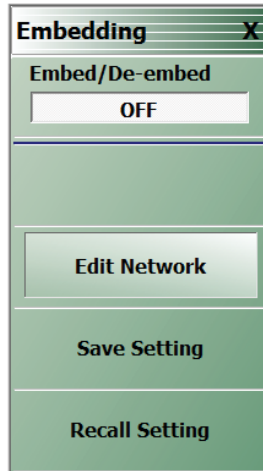

Figure 9-2. EMBEDDING Menu

Clicking on Edit Network displays the main EDIT EMBEDDING/DE-EMBEDDING dialog box. An example with Embedding, L Circuit, and L(S) selected, but with no network information entered is shown in the figure below.

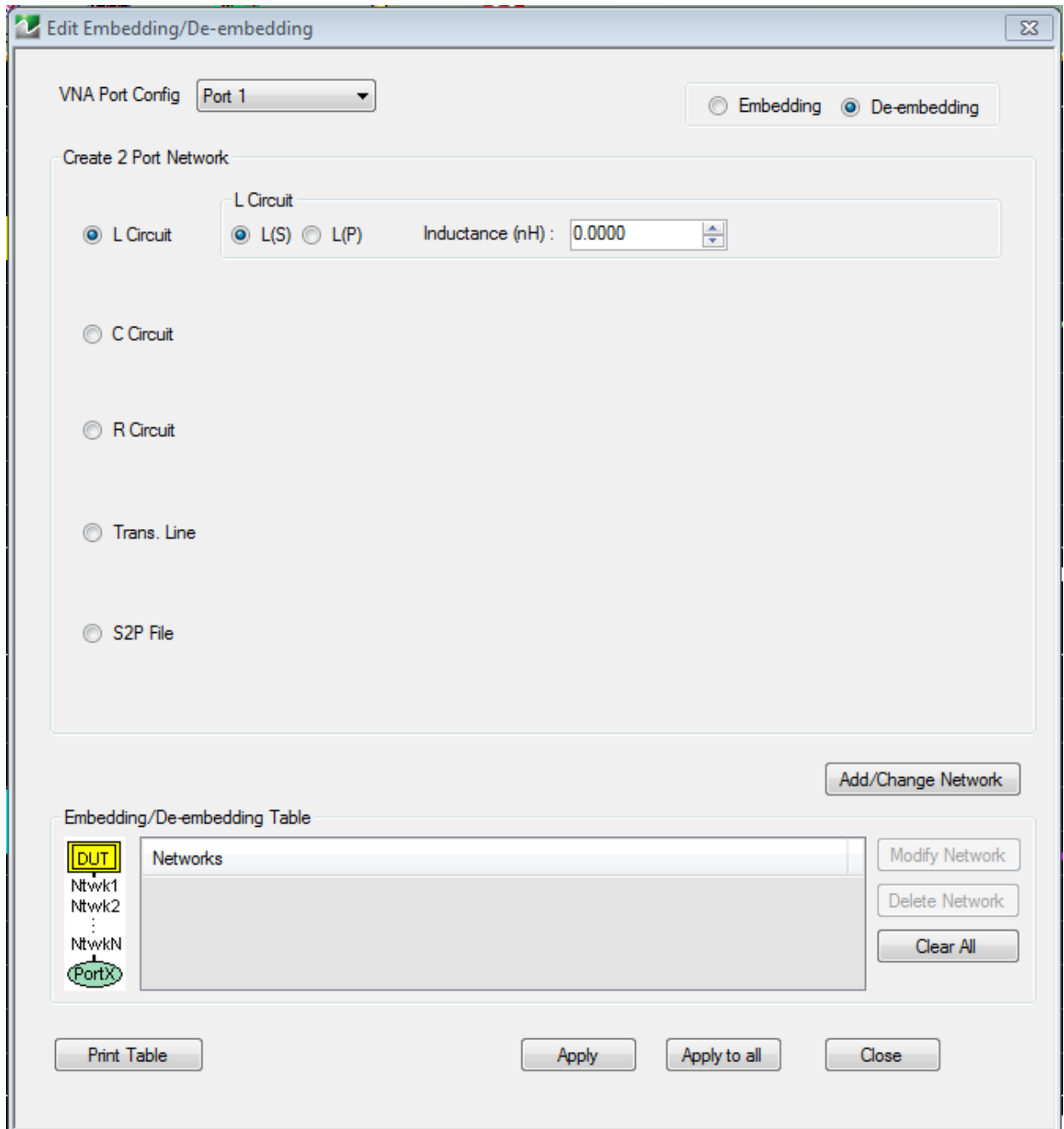

Figure 9-3. EDIT EMBEDDING/DE-EMBEDDING (2 PORT DUT) Dialog Box - L Circuit

Note

Embedding and de-embedding is setup for each port and the networks used on the two ports are entirely independent. Also, any number of networks can be cascaded at a given port and the first network entered is always nearest the DUT.

The key concepts for embedding and de-embedding are:

- Networks are setup on a per-port basis
- The networks used on the two ports are entirely independent
- Any number of networks can be cascaded at a given port

The first network entered is always nearest the DUT. The pull-down menu at the top of [Figure 9-3](#) shows which port's networks are currently being edited. The diagram in [Figure 9-4](#) illustrates the independence concept.

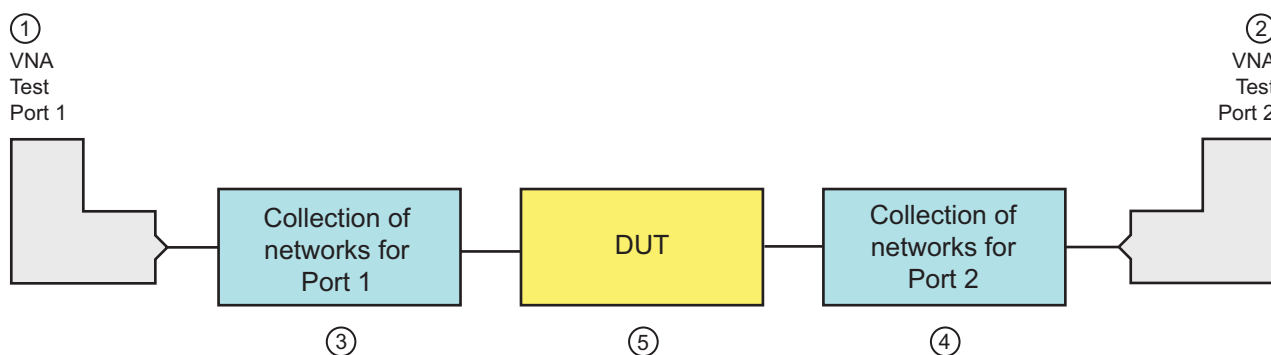

1. Test Port 1

2. Test Port 2

3. Collection of networks attached to Port 1.

4. Collection of networks attached to Port 2.

5. DUT attached to Port 1 networks (at left) and Port 2 networks (at right).

Figure 9-4. Global E/DE Diagram Showing Independence of Port Networks

Types of E/DE Networks

There are five types of networks that can be entered:

- Inductive elements
- Capacitive elements
- Resistive elements
- Transmission lines
- .S2P-defined, file-based networks

In the EDIT EMBEDDING/DE-EMBEDDING dialog box in [Figure 9-3](#) above, the radio button for entering an LC network has been selected. An additional version of the dialog box is shown in the figure below where a C(S) network has been selected.

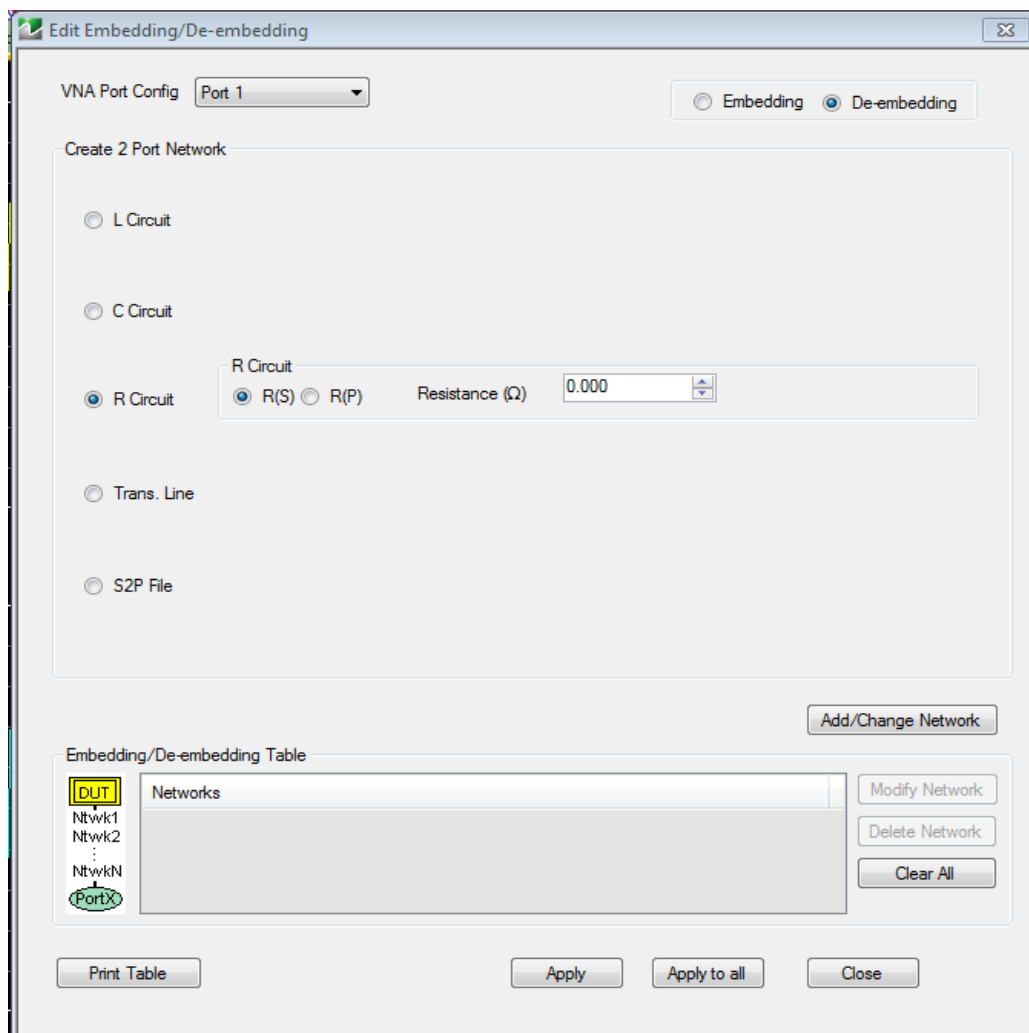

Figure 9-5. EDIT EMBEDDING/DE-EMBEDDING - C Circuit

Entry Mode for Resistive Elements

The entry mode for these resistive elements is shown in the E/DE dialog box below (Figure 9-6). Both series (denoted by an (S)) and shunt (to ground) elements (denoted by a (P) for parallel) are allowed and selectable with the radio buttons. Since this element is symmetric, no orientation knowledge (with respect to DUT port and VNA port) is needed. The default units are:

- Inductance: nH
- Capacitance: pF
- Resistance: ohms

It should be emphasized that the shunt or (P) elements are always shunting to ground (not to the other port). If cross-port elements are desired, then the multiport version of the instrument should be used with an appropriate calibration.

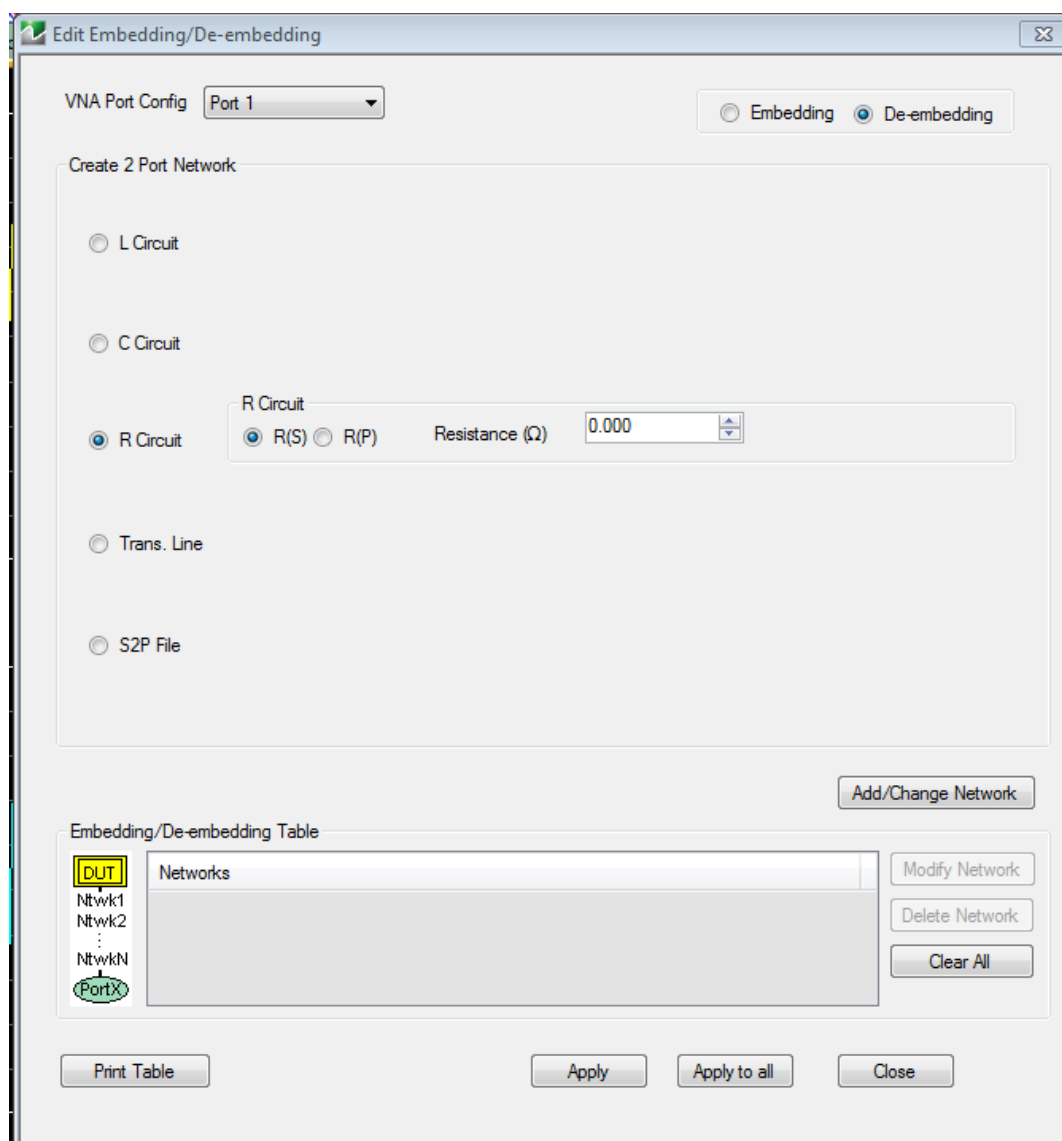

Figure 9-6. EDIT EMBEDDING/DE-EMBEDDING Dialog Box - R Circuit Setup Selected

Entry Mode for Transmission Lines

Transmission line entry is illustrated in the E/DE dialog box below (Figure 9-7). As with transmission line entry in other parts of the system, loss can be entered along with a reference frequency. The loss at other frequencies will be computed using:

$$\text{Loss}(f) = \text{Loss}(f_0) \times \sqrt{\frac{f}{f_0}}$$

Eq. 9-1

As elsewhere in the system, if a 0 (zero) frequency reference is entered, the loss value entered will be used as a constant at all frequencies.

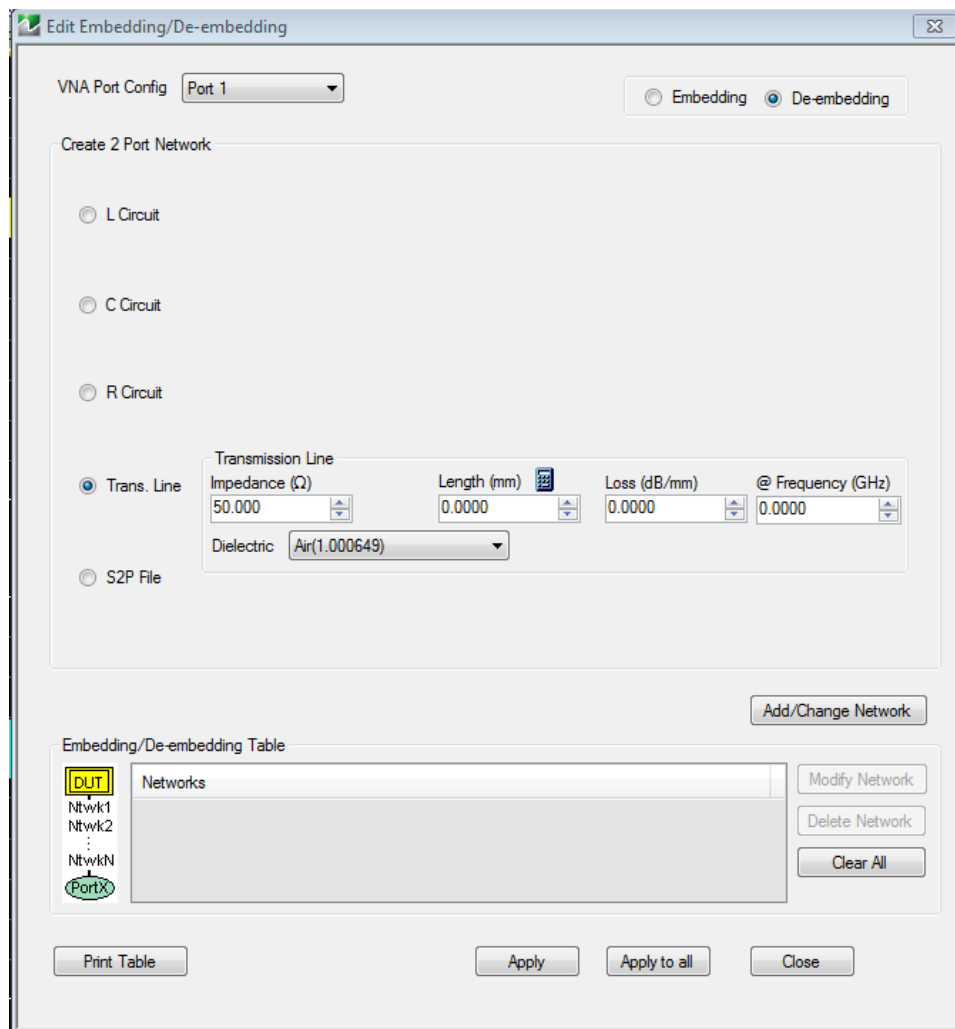

Figure 9-7. EDIT EMBEDDING/DE-EMBEDDING Dialog Box

Physical line length is normally entered here along with a dielectric constant but the Calculator icon shown in above in Figure 9-7 can be used (which links to the AIR EQUIVALENT LENGTH CONVERSION dialog box) if only a time delay is known. Again, since this element is symmetric, no orientation knowledge is needed.

Entry Mode for S2P Defined File-Based Networks

Finally, direct file entry of network S-parameters is shown in the E/DE menu below (Figure 9-8). A standard S2P file format is assumed and the headers will be interpreted. The system will attempt to interpolate the provided data the best it can in the context of the current channel sweep range. If there is no overlap between the sweep range and the file frequency range, an error will be generated.

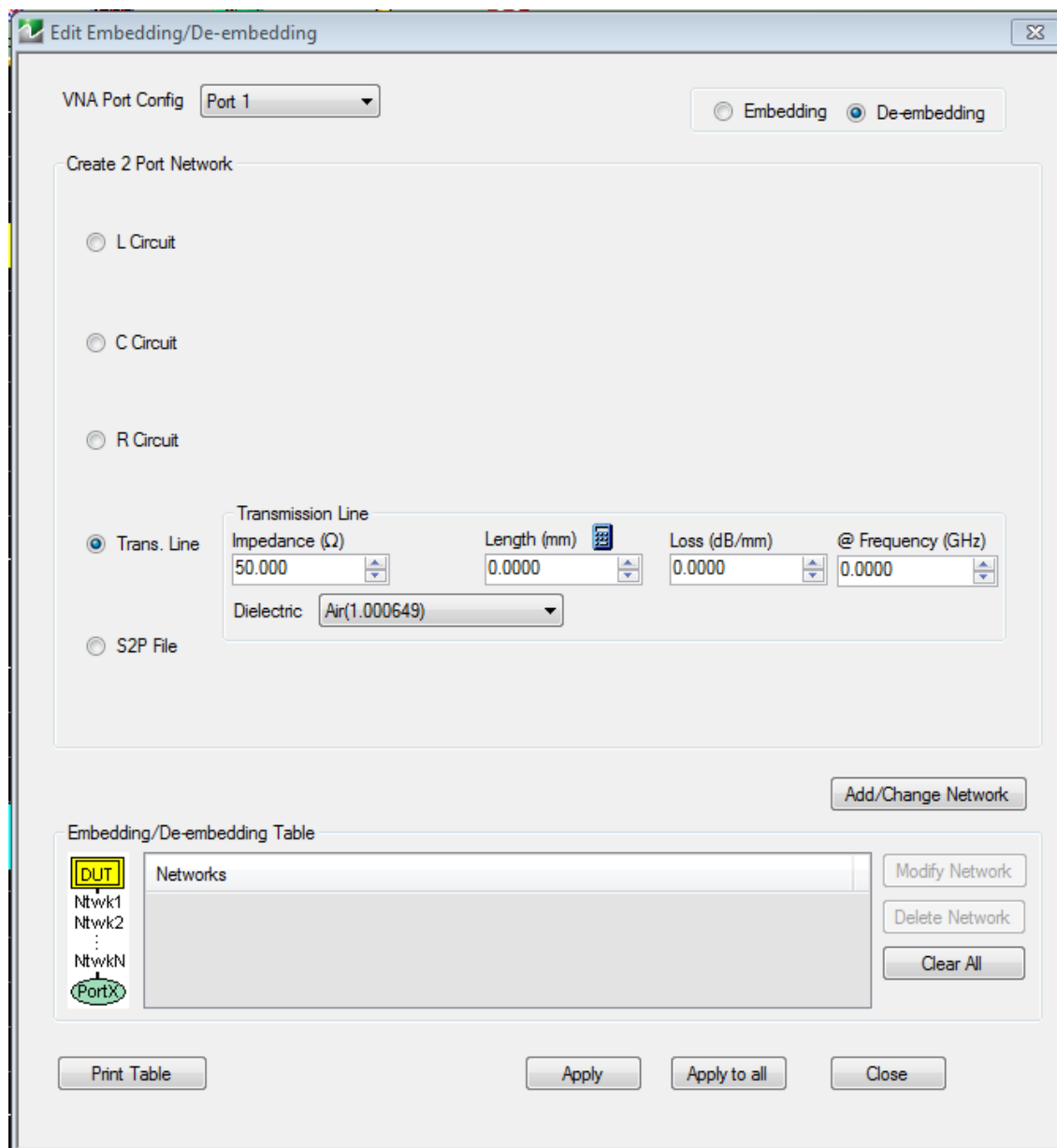

Figure 9-8. EDIT EMBEDDING/DE-EMBEDDING Dialog Box

Note

The network Port 2 is always assumed to be closer to the DUT regardless of which VNA port is involved. See Figure 9-9. If “Swap port assignment” is checked, the relationship is reversed.

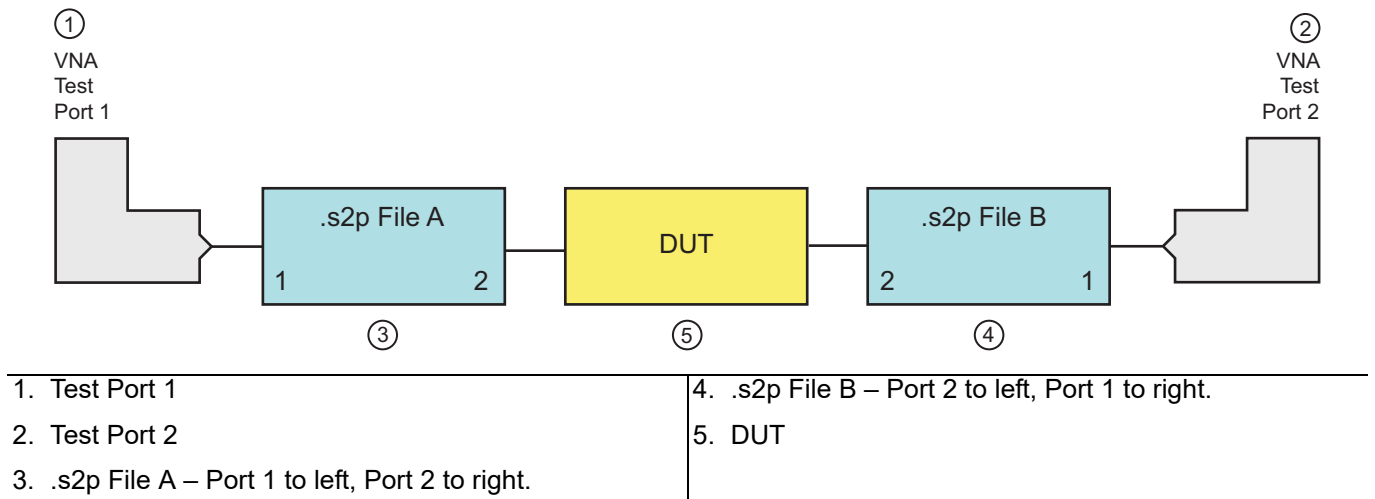

Figure 9-9. Orientation of Loaded S2P Files

Saving and Recalling Embedding Network Configuration

Once a set of networks (consisting of one or more individual networks) is defined, the E/DE configuration information can be saved to a file using the **Save Setting** button on the **EMBEDDING** menu (Figure 9-2, “**EMBEDDING Menu**” on page 9-4). Similarly, a stored E/DE setup can be recalled by using the **Recall Setting** button on the **EMBEDDING** menu.

The current E/DE setting is also saved as part of the primary setup save (under the menu bar **File** menu) but multiple embedding and de-embedding circuits can be saved in these menus as well.

9-3 Reference Plane Control

A simplified means of performing de-embedding (and embedding in some contexts) can be accomplished using reference plane control. The function of this control is to remove transmission line lengths from the data. By entering a time or distance, this length of line will be removed (negative lengths are allowed to effectively add length). Various dielectrics and the full dispersion choices (see calibration section of the Measurement Guide for more information) are available as shown in the REFERENCE PLANE control menu below (Figure 9-10). The ports are handled independently, as in E/DE, and the current port being affected is indicated by the toggle at the top of the menu.

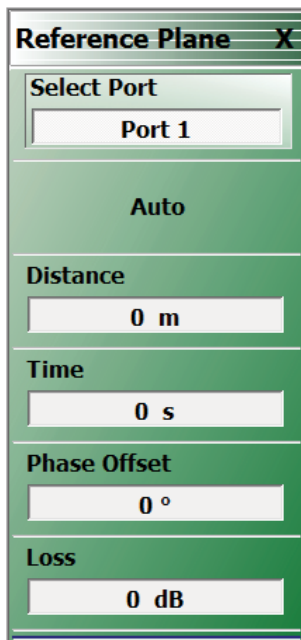
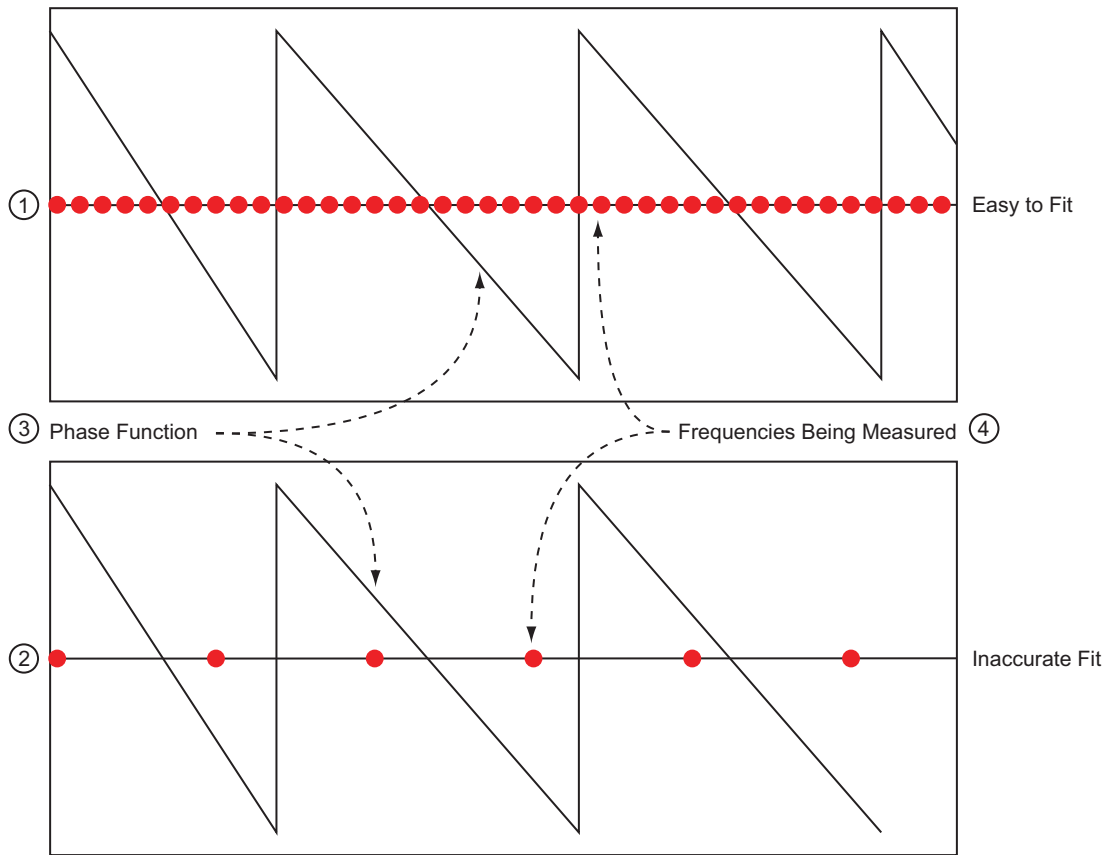

Figure 9-10. REFERENCE PLANE Control Menu

Auto Button Functions

The Auto button performs a best fit operation to the current phase data to estimate the equivalent line length. It will attempt to generate a line length that, when removed, will make the phase flat. This routine will be less accurate if the DUT has very non-linear phase (a dispersion function not matching that selected) or if the DUT is electrically long relative to the current frequency step size. This latter problem, related to aliasing, occurs because not enough information is being collected relative to the true behavior of the DUT phase function (see Figure 9-11 below). Increasing the frequency point density can help this problem.



- 1. Easier to Fit – Small frequency step size compared to phase function is easier to fit and yields higher accuracy.
- 2. Inaccurate Fit – Larger frequency step size compared to phase function is can produce inaccurate results.

- 3. Phase Function
- 4. Frequencies being measured.

Figure 9-11. Auto Reference Plane Function, Frequency Step Large Relative to Phase Period

The auto reference plane function can produce inaccurate results if the frequency step (the distance between the red ovals in the figure above) is large relative to the phase function period.

9-4 Impedance Transformation

Most VNA calibrations are performed referenced to 50 ohms, as this is usually set by the calibration kit. While some calibration kits exist for other impedances (75 ohm N and F connectors for example), they are not common and a custom impedance may be of interest. The impedance transformation function allows performance of a calibration in one impedance and then transform the result to appear as if it had been calibrated in a different impedance. As a crude example, if a 75 ohm N calibration kit is not available, but a 50 ohm kit is, neglecting issues with adapters, the 50 ohm calibration could be performed and the utility used to reference the results to 75 ohms. The IMPED. TRANS. (IMPEDANCE TRANSFORMATION) menu for this function is shown in [Figure 9-12](#).

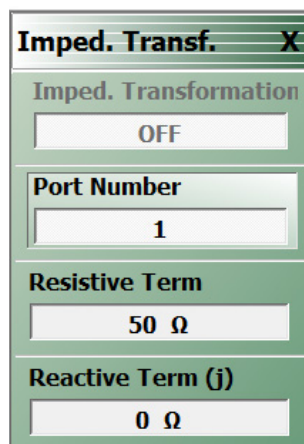

Figure 9-12. IMPED. TRANSF. (IMPEDANCE TRANSFORMATION) Menu

The impedances can be set on a per port (single-ended) basis or a per mode (differential vs. common-mode) basis. On a per-port basis, use the port number toggle to select the current port for entry. On a per-mode basis, select the mode for a given pair with the toggle/dialog.

The per-port and per-pair entries are obviously inter-related and the system will convert the values when switching between per-port and per-mode entries. If per-mode entries are being used, Z_c is the common mode impedance, and Z_d is the differential mode impedance, then the per-port impedances Z_a and Z_b are given by [Eq. 9-2](#) and [Eq. 9-3](#). In 2-port systems on a per-mode basis, there is no port pair choice as the port pair must be 1-2.

$$Z_a = \frac{Z_d + \sqrt{Z_d^2 - 4Z_c Z_d}}{2}$$

Eq. 9-2

$$Z_b = \frac{Z_d - \sqrt{Z_d^2 - 4Z_c Z_d}}{2}$$

Eq. 9-3

There is an inherent ambiguity in the assignment (Z_a and Z_b could be swapped) as the two modal impedances alone do not give enough information (if the assignment is important, per-port entries should be used). Similarly, given per-port entries of Z_a and Z_b , the modal impedances can be found from [Eq. 9-4](#) and [Eq. 9-5](#).

$$Z_c = \frac{Z_a Z_b}{Z_a + Z_b}$$

Eq. 9-4

$$Z_d = Z_a + Z_b$$

Eq. 9-5

Zero real parts are not permitted for any entered impedance. Certain combinations of modal impedances are not physical (result in per-port impedances with negative real parts) but the system will process those entries anyway, so it may be a good idea to switch to per-port to see what the equivalent port impedances are when using modal entries.

A calibration with a minimum of two ports must be active for impedance transformation to take effect and only those ports currently calibrated will be affected.

9-5 Processing Order

With so many post-processing choices available, it is important to note that the order of operations can matter. A few things are fixed by the way computations are performed and others are changeable to suit user needs. The sequence of computations is as follows for S-parameter measurements:

- Acquire raw data and average/filter
- Apply calibration if enabled
- Apply E/DE if enabled (impedance transform and reference plane)
- Apply parameter conversions if enabled
- Apply time domain if enabled

Reference Plane Processing Sequence

The selectable item is the order in which impedance transformation and reference plane control are applied. This matters since the current impedance state determines the impedance of the line length that is adjusted using reference plane control (unlike in E/DE where the impedance can be specified). The menu to make this order selection is shown below (Figure 9-13).

Group Delay Processing Sequence

The second selectable item concerns the order of the group delay computation and trace memory. If trace memory precedes group delay (normal), then the complex operation can precede the numerical differentiation that is part of group delay. This could be useful to do a data normalization prior to connecting a DUT. If group delay precedes trace memory then the trace match will act on the final group delay result. An example might be a group delay comparison using data(-)memory.

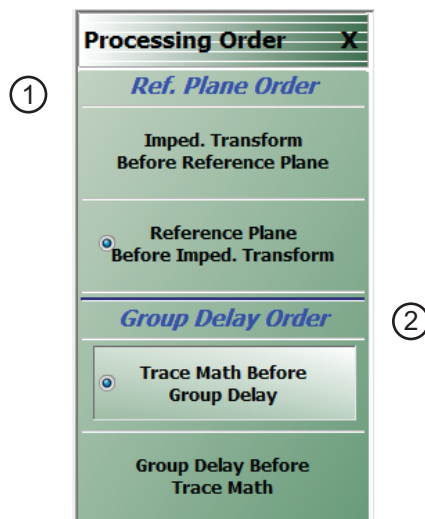

1. Reference Plane Order controls (at top).

2. Group Delay Order controls (at bottom).

Figure 9-13. PROCESSING ORDER Menu

9-6 Conversions

While S-parameters (or the un-ratioed wave parameters) are usually the display variables of interest, conversions to other parameters may be required and are possible with the ShockLine VNA.

1/S is sometimes plotted, particularly for oscillators and other negative resistance devices, where it is desirable to fold the outside of the Smith chart back to the inside. Equivalent impedances and admittances are commonly needed for device modeling and the Z and Y conversions can be used for this (note that these are not, in general, Z and Y parameters).

For each of these parameters, a conversion mode of reflection or transmission must be selected which indicates how the current parameter is to be interpreted. The calculations proceed as follows where X indicates the current displayed parameter such as S₁₁, S₂₁, b₁/a₁, b₂/a₁, and user-defined parameters:

$$Z_{reflection} = Z_0 \frac{1 + X}{1 - X}$$

$$Z_{transmission} = Z_0 \frac{2(1 - X)}{X}$$

$$Y_{reflection} = \frac{1}{Z_0} \frac{1 - X}{1 + X}$$

$$Y_{transmission} = \frac{1}{Z_0} \frac{X}{2(1 - X)}$$

Eq. 9-6

Note that reflection Z or Y values here represent shunt impedances or admittances while the transmission values represent series impedances or admittances.

All of the choices available are on the CONVERSION menu shown in the figure below. Note that this function is *PER TRACE* and is located in the DISPLAY menu.

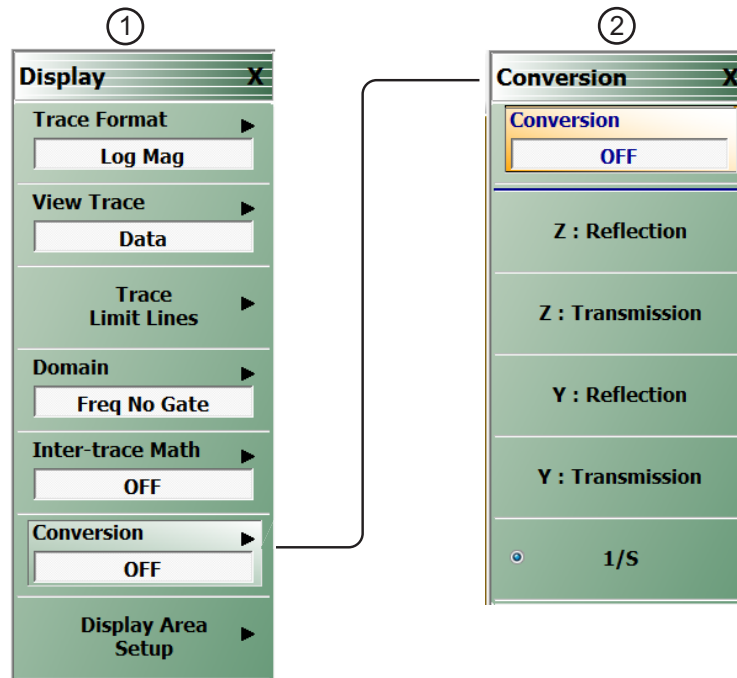

1. DISPLAY Menu (on left).

2. CONVERSION Menu (on right).

Figure 9-14. Conversion Control Menu

The calculations are a function of the current reference impedance which defaults to the calibration reference impedance unless impedance transform has been used (see the section above on [“Reference Plane Control”](#) on page 9-12) or the trace reference impedance has been changed.

Chapter 10 — Verification

10-1 Introduction to Verification

While there are many ways of verifying instrument performance, including the procedures described in the **ShockLine MS46122A/B or MS46322A/B Series VNA Operation Manual**, sometimes a simpler procedure can be useful. Verification kits available from Anritsu verify the measurement capabilities of the instrument by analyzing the measurement of artifacts that are traceable to national standards laboratories.

This chapter introduces and describes the verification process. Verification kits and software are available as a separate product and are described in detail in their associated documentation listed below:

- MS46122A/B Series VNA Operation Manual – 10410-00340
- MS46322A/B Series VNA Operation Manual – 10410-00335
- 3653A Mechanical Calibration Kit Reference Manual – 10410-00278
- Performance Verification Software (PVS) User Guide – 10410-00766
- PVS Quick Start Guide – 10410-00740
- 3663-2 Verification Kit (for Type N Connectors)
- 3668-2 Verification Kit (for Type K Connectors)
- 3668-3 Verification Kit (for Type K Connectors)

See [“Calibration Kits, Verification Kits, and Test Port Cables”](#) on page 1-3.

10-2 Basic Concepts

There are many levels to the concept of VNA verification which is a comparison against expected behaviors.

Hardware Level

On the explicit VNA hardware level are operational checkout items such as port power, receiver signal levels, and noise levels. These items are covered in the Operation Manual. On the calibrated instrument level (which includes the VNA and the calibration kit or Calibration) are the residual specifications (corrected directivity, source match, load match, and tracking) which are measured using traceable airlines (absolute impedance standards).

Intermediate System Level

An intermediate level which can look at overall system behavior (VNA, calibration kit, cables, environment) in a traceable fashion is through the use of a verification kit. While not intended for day-to-day use, the verification kit can provide a periodic check on system behavior without going through the rigor needed for full residual analysis (which can usually be done less often).

Comparison to Known Devices

The central idea of the verification kit is to have a collection of “known” devices (not calibration components) that have been measured with a calibrated VNA. By comparing the results to the “known” values, some measure of confidence can be gained in the measurement abilities of the VNA-under-test. The values in all cases are vector quantities so that both magnitude and phase responses are analyzed.

The “known” part of this discussion involves a process termed characterization performed on the same devices by Anritsu. Through a traceable process, a VNA at the factory is calibrated and validated against controlled standards before being used to measure the devices that go into the verification kit that is delivered to the user. By carefully controlling this process, measurement uncertainties on the characterization end can be carefully controlled. This allows a useful window to be defined as to what an acceptable measurement result is. At each frequency point, the measurement is compared to the characterization measurement in the context of the uncertainties. If the delta between the two measurements is consistent with the uncertainty window, the measurement is considered acceptable at that point.

Metric of Comparison

The metric of comparison, termed E_n , is a check to see if the measurement differences are consistent with the uncertainty windows of both the characterization and the verification measurements. The quantity is shown below:

$$E_n = \frac{|S_{xy}^{\text{char}} - S_{xy}^{\text{ver}}|}{\sqrt{(U_{xy}^{\text{char}})^2 + (U_{xy}^{\text{ver}})^2}}$$

Equation 10-1

The numerator contains the S-parameters measured during characterization (by Anritsu) and during verification (by the user), and the denominator contains the respective uncertainties. These uncertainties are calculated based on the VNA, the calibration kit, and repeatability. If this quantity E_n is less than 1, then the measurements during the two phases are within the overlap of the uncertainties and can be considered “equivalent” and, in some sense, verified.

Verification Kit Creation Process

The general process of the creation and use of a verification kit is shown in Figure 10-1.

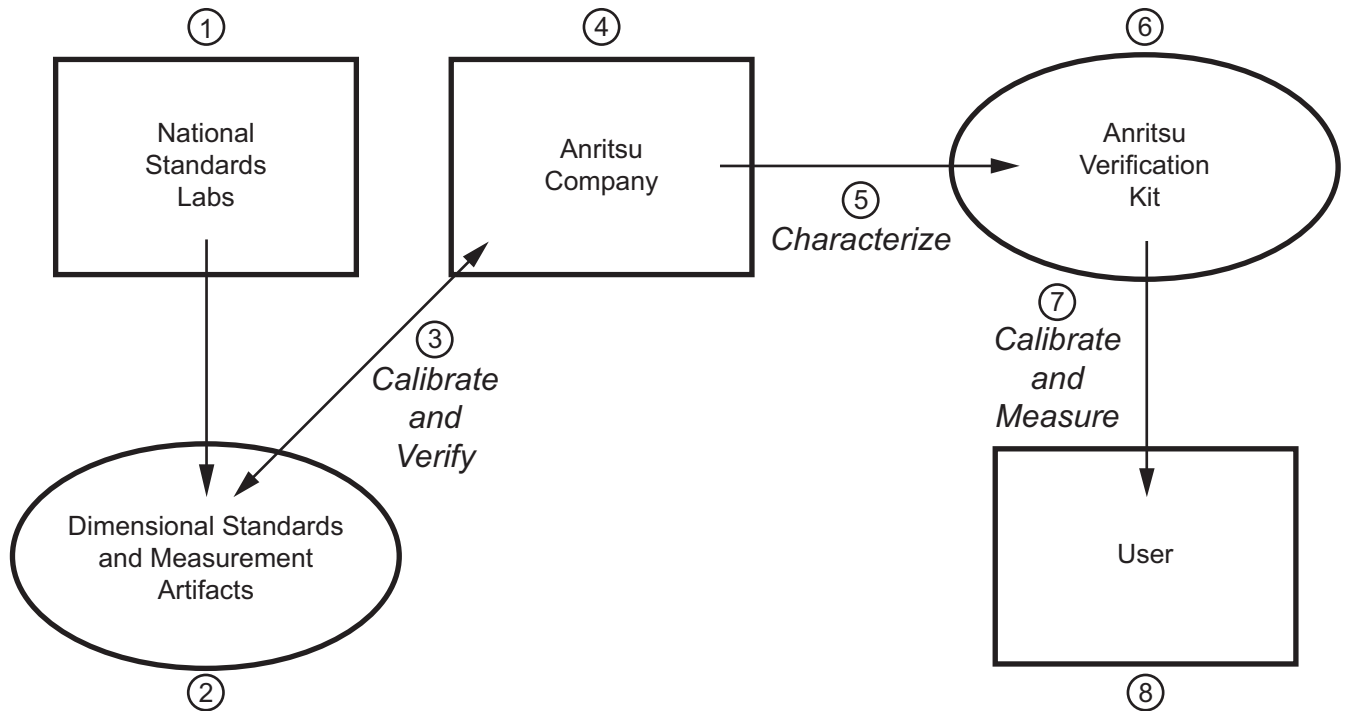

- | | |
|---|--|
| 1. National Standards Labs. | 5. Characterization processes for verification kits. |
| 2. Dimensional standards and measurement artifacts. | 6. Anritsu Verification Kits with characterization data. |
| 3. Calibrate and verify using artifacts. | 7. Calibrate instruments and measure DUTs. |
| 4. Anritsu Company processes and standards. | 8. Verification kit used to verify instrument calibration. |

Figure 10-1. General Process of the Creation and Use of a Verification Kit

A national standards laboratory (through standards and measured artifacts) helps validate the calibration and Anritsu which is then used to characterize the verification kit sent to the user.

It is important to note that the results are influenced by not only the instrument, the calibration kit, and the verification kit, but also the cables, the environment (temperature, humidity and vibration), connector quality, and the care exercised by the user during calibration and measurement. It should also be emphasized that this is not a measurement against absolute standards (which is the case for the residuals measurement process) but is a study of an “equivalent” measurement; the same devices measured with the instrument at the user site versus those devices measured with a controlled instrument at Anritsu (under traceable conditions).

10-3 Verification Kit Components

The verification kits for the ShockLine Series VNAs are:

- 3663-2 MS46122A, MS46322A Verification Kits (for Type N Connectors)
- 3668-2 MS46122A, MS46322A Verification Kit (for Type K Connectors)
- 3663-3 MS46122B, MS46322B, MS4652xB Verification Kits (for Type N Connectors)
- 3668-3 MS46122B, MS46322B, MS4652xB Verification Kit (for Type K Connectors)

The verification kits and their use are described in the following documents:

- Performance Verification Software (PVS) User Guide – 10410-00766
- PVS Quick Start Guide – 10410-00740

The devices in these kits are selected based on their ability to stress the envelope of possible measurement parameters while still providing a very stable and repeatable behavior. The key attribute of the devices is that of long term stability.

These kits contain the following devices:

- An airline to represent a low loss, well-matched device.
- A stepped impedance (Beatty) airline to represent a variable match device with a range of insertion losses.
- A 20 dB attenuator to represent a moderate loss, well-matched device.
- A higher value 50 dB attenuator to represent a very lossy device.

No Verification with Calibration Kits

Calibration kit components cannot be used for verification since the result would be biased (some calibrations force the result to match expectations for the components used during calibration). Higher loss devices could have been used but they become more difficult to characterize accurately and the value of the verification would be reduced. Active devices with gain have not been used due to concerns about stability of the response over time. The envelope of coverage of the existing standards is illustrated in [Figure 10-2, “Regions of Parameter Coverage of Verification Kit Component” on page 10-5](#). Each standard has a regime of coverage in terms of insertion loss and return loss; when combined, the entire kit reasonably exercises a wide variety of parameter values.

The diagram in [Figure 10-2](#) illustrates the regions of parameter coverage of the various verification kit components. The regions are not drawn to scale.

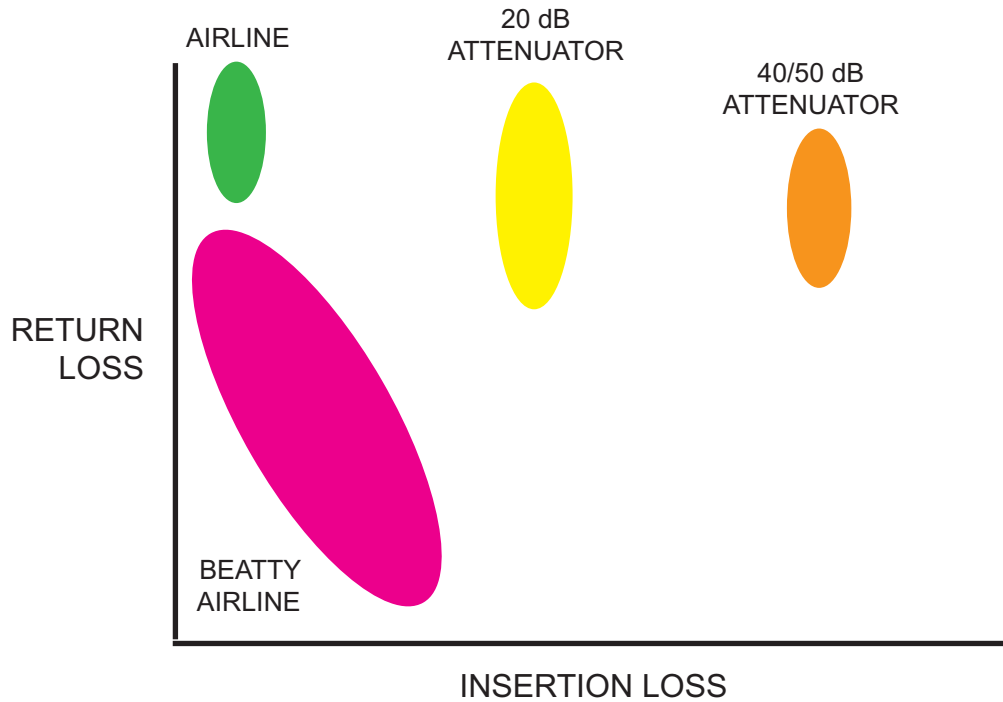

Figure 10-2. Regions of Parameter Coverage of Verification Kit Component

For the MS46122A/B, 131A, 322A/B, ME7868As, the verification comparison is valid for calibrations performed with the calibration kits listed under the verification kit:

- 3663-3 Type N Connector Verification Kit
TOSLNF50A Type N Manual Calibration Kit
- 3668-3 Verification Kit (for Type K Connectors)
TOSLKF50A-40 Type K Manual Calibration Kit
- 3668-4 Verification Kit (for Type K Connectors)
TOSLKF50A-43.5 Type K Manual Calibration Kit
- PVS Quick Start Guide – 10410-00766

Other combinations of calibration kits with verification kits are not supported. Verification kits based on other connector types such as GPC-7 exist for other Anritsu VNAs but the MS46122A/B, 131A, 322A/B, ME7868A verification software does not support all of these.

10-4 Verification Kit Software

The application provided with the verification devices prompts calibration of the VNA, acquires measurements of the devices, and compares those measurements against the characterization values generated by Anritsu (these values ship with the verification kit). The software also generates reports indicating the outcome of the verification. More information is available in the user guide provided with the verification kit:

- Performance Verification Software (PVS) User Guide – 10410-00766
- PVS Quick Start Guide – 10410-00740
- 3663-3 Verification Kit (for Type N Connectors)
- 3668-3 Verification Kit (for Type K Connectors)

Chapter 11 — Measurement Setup Requirements

11-1 Chapter Overview

This chapter provides general measurement setup fundamental concepts, requirements, and options for different types of measurements. Specifically, this chapter describes traces, limit lines, external analog input/output, averaging and smoothing, and organizes their configuration in the same hierarchy. Traces are concepts that represent a data group with a maximum of 16 traces for MS46122A/B and MS46322A/B. Limit lines are described with setup tasks and test functionality. External analog input/output is described with setup issues, range, functions, resolution, and accuracy. A description of averaging and smoothing with their available functions and the effects on measurements conclude the chapter.

11-2 Channels and Traces Introduction

Two of the central concepts in the MS46122A/B and MS46322A/B VNA that will enable the maximum functionality of the system are channels and traces.

Channel Concept

At a high level, the channel defines the sweep configuration and the calibrations for a measurement. Sixteen channels are possible and each can have a different frequency range, different power levels, different IF bandwidths and different RF calibrations (among other things). In a sense, 16 distinct VNAs within one instrument are possible with each one executing sequentially.

Trace Concept

The trace is a concept that represents a data group. Sixteen (16) traces are available on the MS46122A/B and MS46322A/B family. Each trace can represent a different response parameter, can be on a different graph type, and have certain different levels of post-processing applied to it.

The objective of this section is to explore how the traces can be setup, what possibilities are available, and what configurations are commonly used.

11-3 Measurement General Concepts

The hierarchy of setups is illustrated in Figure 11-1. At the highest tier is per-system, these are variables that apply to all measurements on a given physical instrument. There are very few of these variables and they include:

- Certain portions of the hold system and certain triggering functionality
- Cal kit files
- SnP and text file header/format setups
- Blank frequency display (security feature)
- Interface setup items (network config, touchscreen setup)

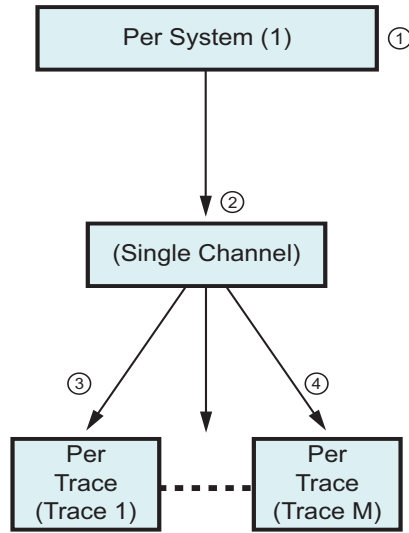

Setup Hierarchy – System then Traces

- | | |
|--|---|
| <ol style="list-style-type: none"> 1. Per System Settings – These settings affect the entire instrument. 2. Single Channel – The default setting. Up to 16 channels can be active. | <ol style="list-style-type: none"> 3. Per Trace Settings – Each trace can be configured as a separate measurement, with separate markers, and a different display method. 4. Each trace can have up to 12 total measurement markers and one (1) reference marker. |
|--|---|

Figure 11-1. Setup Information Hierarchy

Per-System Variables

These variables are often per-system to prevent a setup scenario that could significantly shorten the life span of the hardware. In the case of hold and triggering, it also allows an entire measurement suite to be more easily controlled externally. Others fall more in the category of utilities that are somewhat per-system in nature. M (the trace count) may always be up to 12 on MS46122A/B and MS46322A/B.

Per-system variables apply to all measurements on a given physical instrument. These variables include:

- Portions of the hold system and triggering functionality
- AutoCal characterization files and Cal kit files
- SnP and text file header/format setups
- Blank frequency display security feature
- Interface setup items such as network configuration

11-4 Channels and the Channel Menu

The second tier is that of the channel. As mentioned in the overview, the channel can almost be thought of as a separate virtual VNA. Although this term has been used differently in the past with other Anritsu VNAs, in the MS46122A/B, 131A, 322A/B, ME7868A Series family, the variables include a frequency list, calibrations and sweep control

The channel menu itself is fairly simple. While the system defaults to 1 channel (under a preset command), here a different number of channels may be selected. The active channel (indicated by a thick white border) may be selected by clicking on that channel's window or it can be incremented using this menu (Chan. Next and Chan. Previous).

The button Chan. Max can be used to force the active channel to occupy the entire data screen area. Note that the other defined channels will continue to sweep even when this mode is entered. The Chan. Max command is a toggle and can be undone by clicking it again. Chan. Max can also be accomplished by double-clicking the channel area away from a specific graph (that leads to Trace Max discussed later). These commands are illustrated in the top level menu shown in [Figure 11-2](#).



Figure 11-2. CHANNEL Menu

Once a given number of channels is selected, the layout of those channels is selected in a submenu shown in [Figure 11-3](#). Note that selecting a layout with more channels will update the channel count since gaps in the sweep processing are not allowed. Because there are many combinations of channels possible, this window is quite lengthy (shown in two parts in [Figure 11-3](#)).

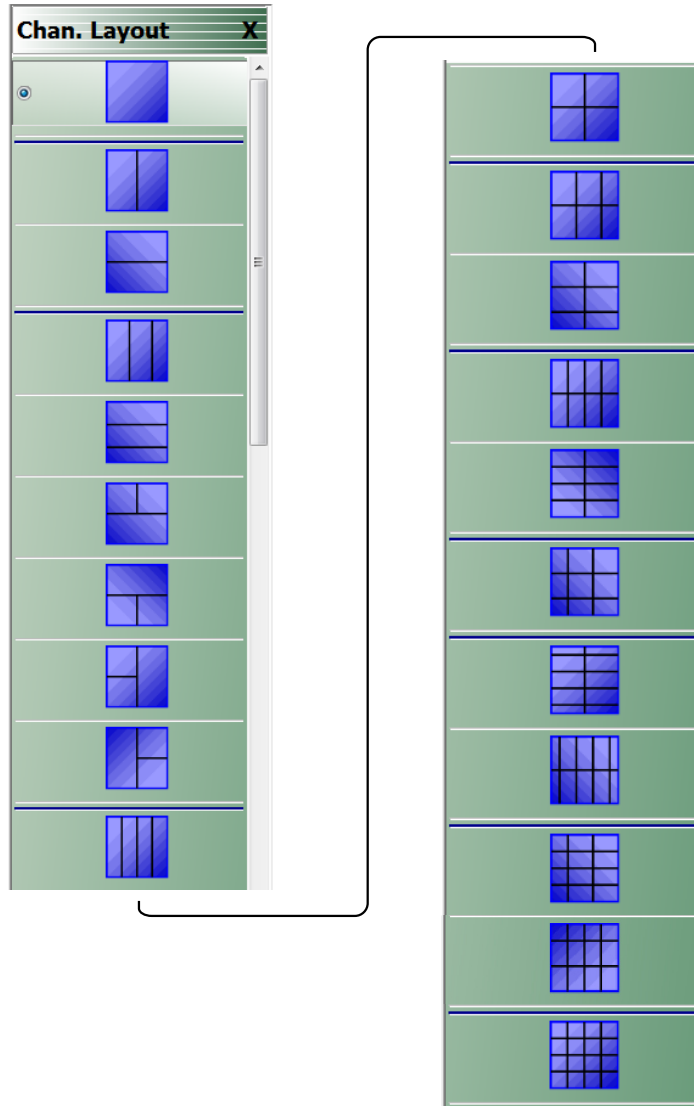

Figure 11-3. CHAN. LAYOUT (CHANNEL LAYOUT) Menu

If multiple channels are available in the VNA, any number of channels can be configured between 1 and 16 channels.

Using the CHAN. LAYOUT menu shown in [Figure 11-3](#) above, layouts are limited to values 1, 2, 3, 4, 6, 8, 9, 10, 12, or 16 channels.

Only those values corresponding to semi-symmetric layouts are allowed as suggested by the channel layout menu and other entries will be coerced.

Once the number of channels and the layout has been selected, it then remains to define each of the channels. The sweep control parameters apply to the active channel so one may cycle through the channels entering values as needed. Alternatively, the setups for a channel may be copied through the setup save/recall mechanism since setups can be saved on a per-channel basis. Note that save/recall can also be applied to all channels.

It has been discussed that most sweep-setup parameters are per-channel in nature. To clearly delineate when these apply, the per-channel functions include:

- Frequency
- Power
- Embedding/de-embedding and reference plane extensions
- Impedance transformations (note that this is distinct from impedance parameter conversions which are a post-processing calculation on trace data)
- Post-processing order
- Media type (dielectric constants, coaxial vs. waveguide, etc.)
- Hold functionality (portions can be per-system)
- Trigger functionality (portions can be per-system or per port as well as per-channel)

11-5 Traces

Up to 16 traces can be specified for display using the # of Traces button of the TRACE menu (Figure 11-4), with sequential trace activation provided by the Trace Next and Trace Previous buttons. Traces can be directly activated by clicking on the graph title, as shown in Figure 11-5. The active trace is indicated by the trace number highlighted with a solid background.

The Trace Max button toggles display of the active trace to and from the full graph area, as does double-clicking on the graph title.

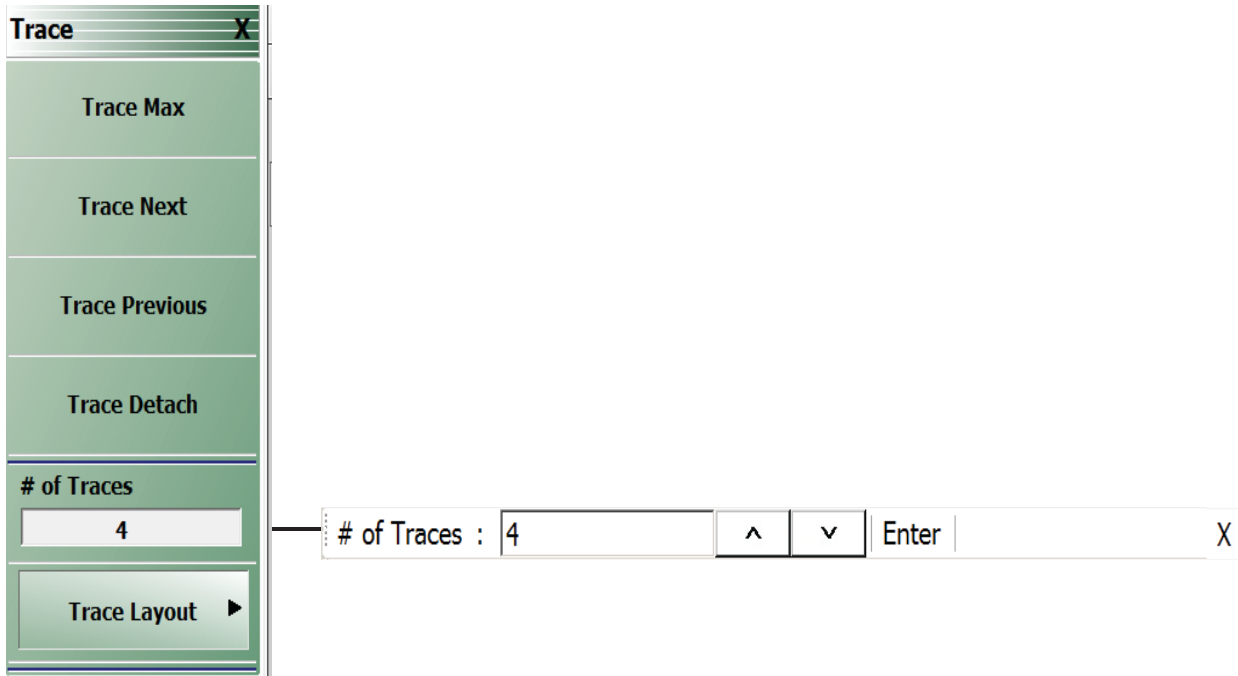

Figure 11-4. TRACE Menu and # of Traces Toolbar

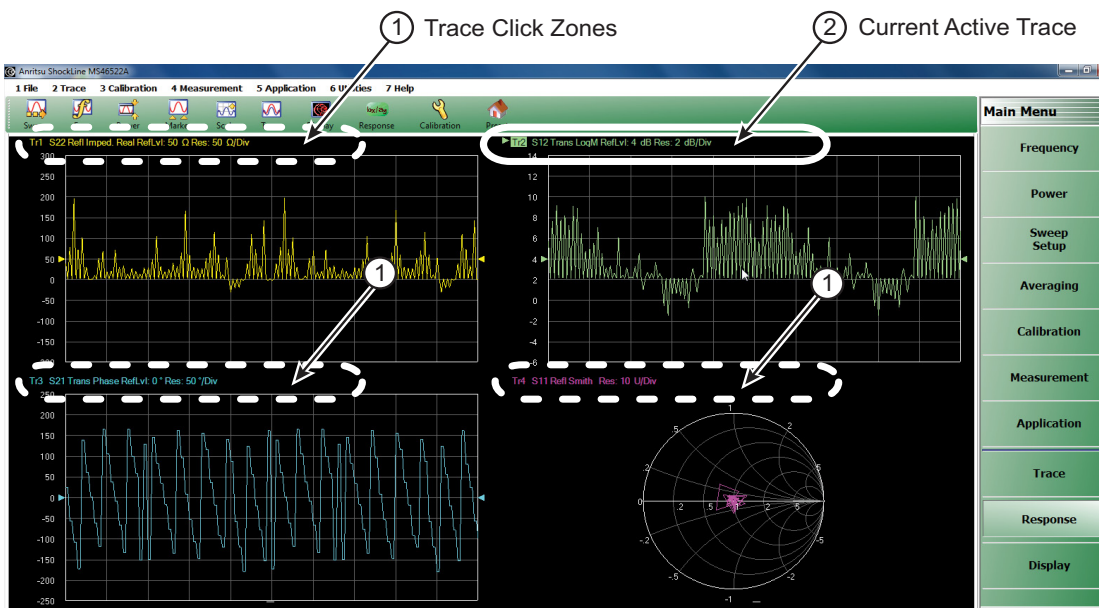

Figure 11-5. Trace Activate Click Zones

The TRACE LAYOUT menu (Figure 11-6) provides 12 trace layout options that support up to 16 traces in any configuration. If the number of traces specified in the # of Traces toolbar exceeds the number of graphs in the selected layout, the extra traces are displayed sequentially as overlays divided among the available graphs, with priority assigned to the first graph.

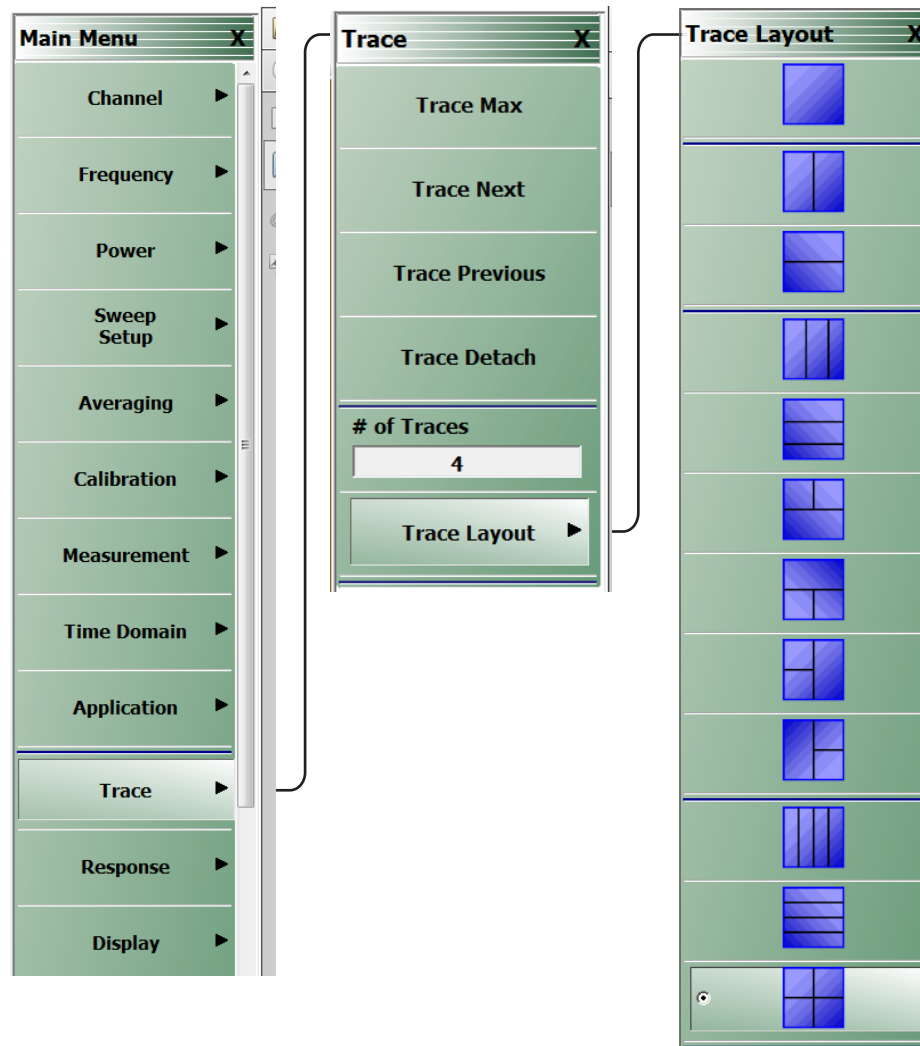

Figure 11-6. TRACE LAYOUT Menu

For example, if four traces are specified in the # of Traces toolbar with the three vertically stacked graphs layout selected from the TRACE LAYOUT menu, the traces will be assigned as follows:

- Top graph area: traces 1 and 4
- Middle graph area: traces 2
- Bottom graph area: trace 3

Similarly, a 16-layer overlay can be displayed by specifying 16 traces and selecting the single graph layout.

Per-Trace Variables

Per-trace variables include:

- Trace format (graph type)
- Trace memory and math functions (to include inter-trace math which is sort of a hybrid but is defined on a per-trace basis)
- Scale (although autoscale can also be per-channel or per-system)
- Domain (time domain and frequency w/ time gate)
- Smoothing
- Conversions
- Limit lines
- Markers (although markers can be optionally coupled between traces within a channel)
- Response: S-parameter, unratioed parameter, ext. analog in

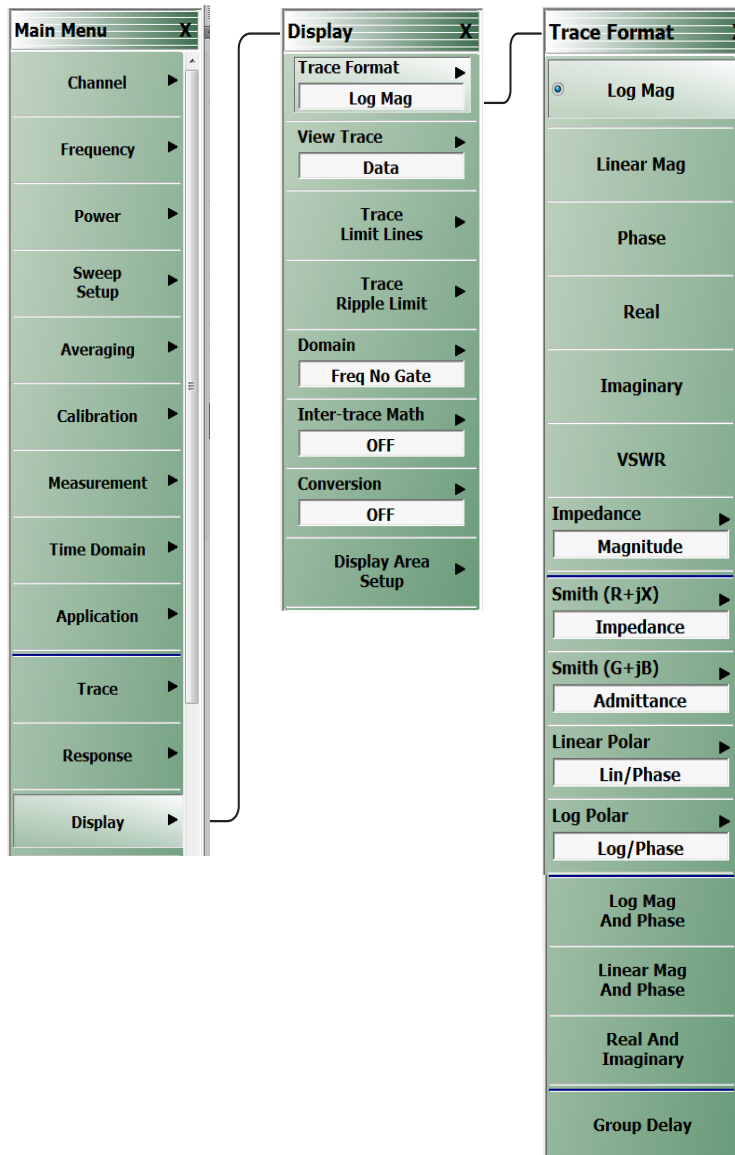

Figure 11-7. TRACE FORMAT Menu

Complex Trace Setup Example

A fairly complex trace setup example is shown in Figure 11-8 below. This example covers multiple graph types and scaling options as well as different transformations applied to the data in certain traces. Symbols at the end of the annotation line provide information about these trace definitions. For example, Trace 2 is showing Data and Memory [D&M], while Trace 3 and Trace 5 are showing Data Memory Math; [D/M], and [D-M] labels. A list of abbreviations and their definitions are shown in Table 11-1. Some of the abbreviations may appear without brackets at the end of the annotation line. Details on these functions can be found in other sections of this measurement guide and the ShockLine Operation Manual.

Table 11-1. Trace Labels and Annotations

Abbreviation	Definition
FGT	Frequency domain with time gating
TLP	Time domain low pass
TBP	Time domain bandpass
D&M	Data and memory
D/M	Data memory math
D+M	
D-M	
D-M	
M	Memory

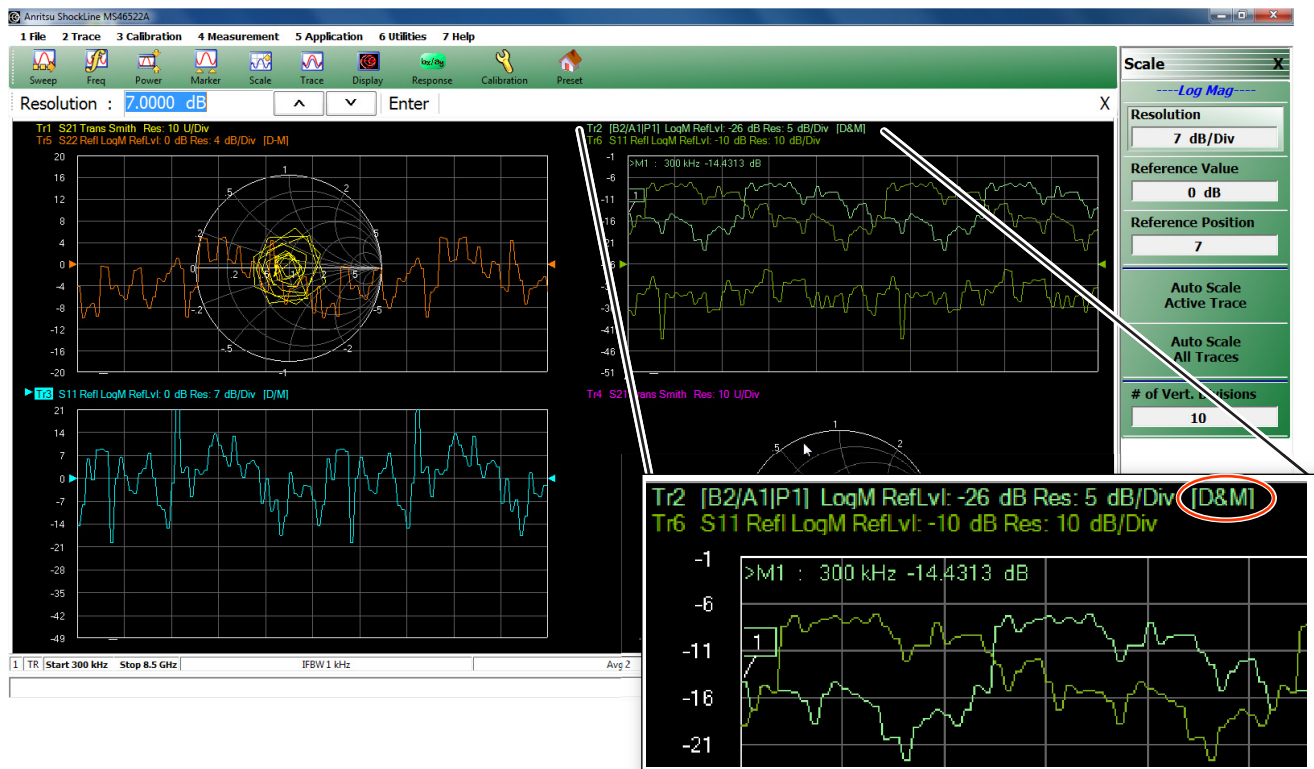

Figure 11-8. Multi-Trace Display with right-side SCALE menu

Figure 11-8 also illustrates an example of a function, auto scale in this case, available on per-trace and per-system levels.

11-6 Trace Math, Inter-trace Math, and Equation Editor

Although some trace manipulations were alluded to in the previous section, there are considerable trace computation capabilities that warrant further discussion. The simplest of these is TraceMemMath where some operation (addition, subtraction, multiplication or division) is applied between current trace data and that stored in trace memory for that trace. Some points of interest:

- The math is always applied on the basic, linear complex numbers....not on the displayed, formatted numbers.
 - Example: The trace is formatted as log mag + phase, the first data point is plotted at 20 dB, 0 degrees and the first memory point is plotted as 40 dB, 90 degrees. Data(/)Memory is selected. This will be computed as $(10+j0)/(0+j100)=-j0.1$. The result will be displayed as -20 dB, -90 degrees.
 - It does not matter if the entire complex value is being presently displayed (e.g., a real-only graph type), the math will be applied to the entire complex number.
 - If the user is commonly using log mag graph types, the math may appear counter-intuitive. If one is measuring S21 with a thru line connected, stores data to memory and selects Data(/)Memory, the immediate result is a flat line near 0 dB since one is dividing current data by something very similar (hence close to 1 in linear terms). If one selects Data(-)Memory, the result will be bouncing near the noise floor since now one is plotting the $20*\log_{10}(|X-Y|)$ where X and Y are nearly identical.
- The math is applied after smoothing.
- The math may be applied before or after group delay, depending on the user selection for order of operations (this matters since group delay is computed as a derivative of phase, so if trace match comes first, it acts on phase).

The math is applied before self-normalization (as used in gain compression)

Inter-trace Math

This function allows one to combine measurements from two traces into a result to be plotted in a third trace position. In the Simple Operation mode, the concept is very similar to trace math just discussed, the available operators are the same and the operations again occur on the base, linear complex value. The difference is that the input variables can come from different traces (with completely different S-parameters or user-defined parameters) and can even be based on trace math in that different trace (hence the Type selection in the menu shown in [Figure 11-9 on page 11-11](#)).

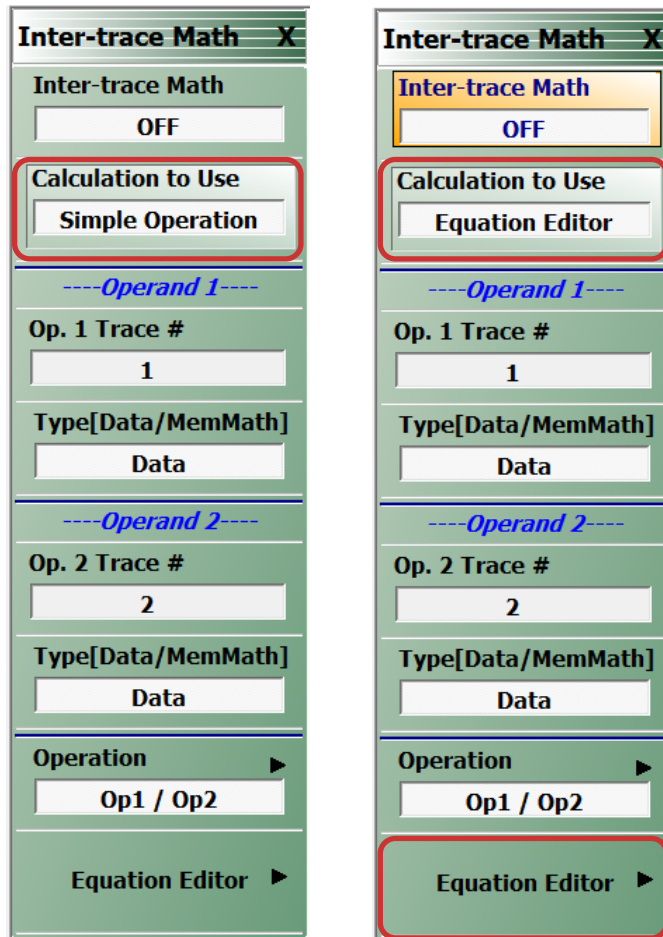

Depending on the 'Calculation To Use' selection, either a simple (+ - * /) operation set with two arguments is allowed (Simple Operation) or a much more complete set of operations and arguments are possible (Equation Editor).

Figure 11-9. INTER-TRACE MATH Menu

An example could be someone wanting to measure S_{21}/S_{12} for a device as a measure of reciprocity (e.g., the device is an isolator). If trace 1 was configured as S_{21} and trace 2 was configured as S_{12} , then the above settings for the Simple Operation would allow a display of the ratio in real-time. In contrast to basic trace math (where one could measure S_{21} , save it to memory, then change the measurement to S_{12} and plot DataMemMath) which would be quasi-static, the inter-trace measurement version allows for observing changes during tuning correctly. On a more advanced level, one could normalize each of the input variables using DataMemMath on those traces and then operate on the normalized variables using Inter-trace math (e.g., $Tr1/Mem1 + Tr2/Mem2$).

Equation Editor

The Equation Editor allows a much more complete set of operations between trace data sets (and S-parameter sets) than does the Simple Operation inter-trace math just described. The main dialog is shown next (see [Figure 11-10 on page 11-13](#) and [Figure 11-11 on page 11-18](#)) and consists of a selection of functions, input variables (traces and S-parameters in various formats, and sNp file selection) and scalar entry along with some editing tools.

A central concept is that the entire equation is based on complex vectors (which is how trace data and S-parameters come in and what is desired for plotting) of length equal to the number of points. Scalars (real or complex) can be used throughout but, where necessary, will be automatically vectorized (same value at each position in a vector of length equal to the number of points).

Example:

Trace 1 has three points [1+j1, 2+j2, 3+j3]. The equation is $\text{Tr1} + \pi$. The result of the calculation will be [(1+ π)+j1, (2+ π)+j2, (3+ π)+j3].

Syntax errors will be flagged if parentheses are not used to resolve precedence problems (e.g., $\text{Tr1} * -\text{T2}$ will not be accepted but $\text{Tr1} * (-\text{Tr2})$ will be).

If the input variable format is selected as **Raw** or **Corrected**, the variable will enter the equation as a linear complex number (either with or without calibration applied; note that receiver calibrations are applied to all). If **Formatted** is selected, the current graph type format will be used so the vector may be purely real.

If the time domain checkbox is selected, all traces and parameters will be processed into time domain in the background if they are not already displayed that way. Lowpass Processing will be used if the current frequency list supports it, but otherwise Bandpass Process will be used. Trace time domain parameters will be used, which may be at default if not already configured. It is recommended to configure desired variables in time domain so the results are predictable. See [Chapter 12 — Measurement – Time Domain \(Option 002\)](#) of this guide for more information.

Note that trace memory and trace math (discussed earlier in this section) can be used as the incoming variables. Constant π (PI) is available and the 'j' button is used for entering complex scalars. The scientific notation exponent marker 'E' is also available (e.g., 1E9 for 1000000000).

Only single-ended S-parameters are available as direct arguments for the editor. Any mixed-mode S-parameter can, however, be created as a trace variable and used that way as an argument. This is because of the wide variety of underlying port permutations possible with the mixed mode parameters.

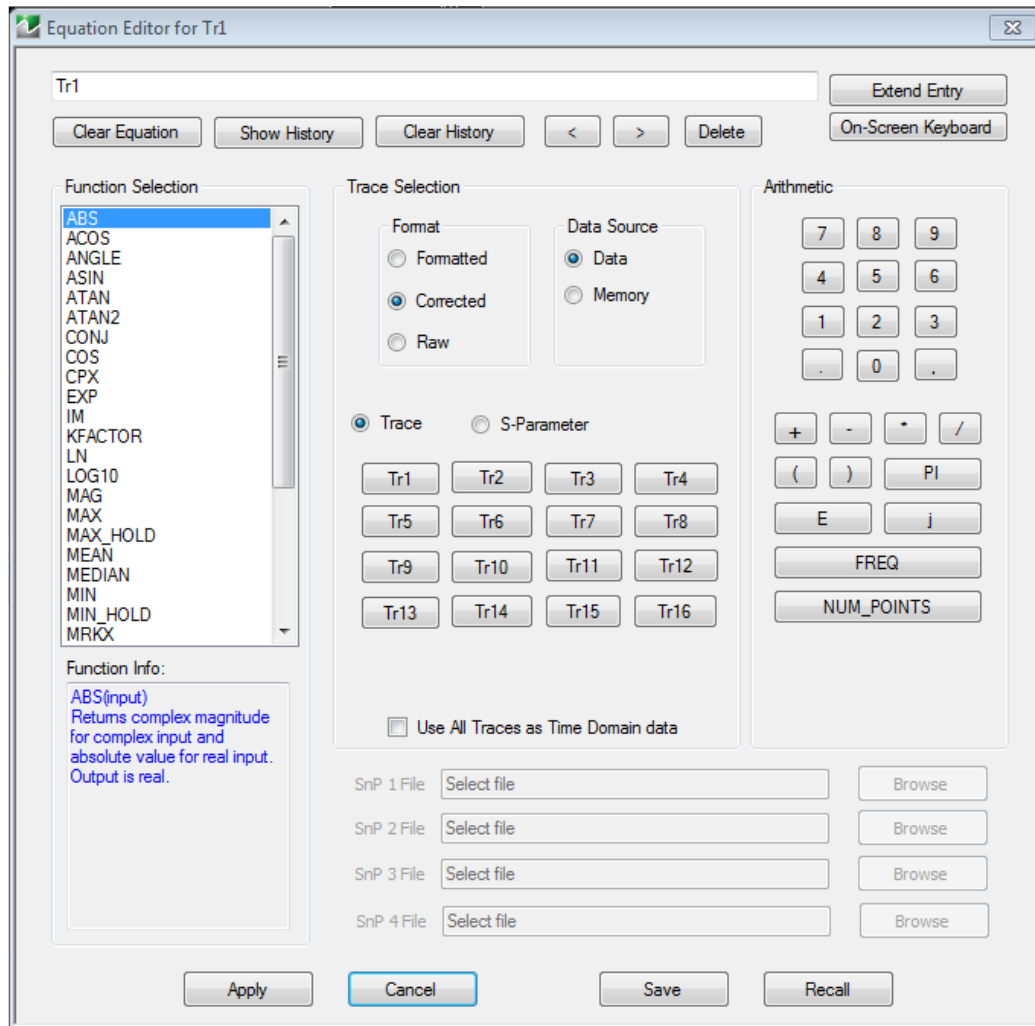

Figure 11-10. EQUATION EDITOR Dialog - Trace Mode

Supported Complex Functions

Following are description of the more complex functions supported (the output of the function is complex unless otherwise noted).

- **ABS()** – Complex magnitude for complex input and absolute value for real input. Output is real.
- **ACOS()** – Arccosine; radian output. This will accept complex arguments and uses the standard branch cut.
- **ANGLE()** – Phase of complex input; radian output. Output is real.
- **ASIN()** – Arcsine, radian output. This will accept complex arguments and uses the standard branch cut.
- **ATAN()** – Arctangent, radian output. This will accept complex arguments and uses the standard branch cut.
- **ATAN2()** – Arctangent with the ability to properly resolve quadrants. The argument is complex and it is internally split into real and imaginary components with sign checking. Radian output
- **CONJ()** – conjugate

- COS() – Cosine, radian input. Note that this function will accept complex inputs and treat them as such. Commonly one would use this function only with a formatted trace set up for phase and then multiplied by pi/180 to convert to radians.
- CPX(a,b) – Complex equivalent taking 2 real inputs; output is a+jb. If the inputs are complex, the real part of each is taken prior to combination into a new complex variable.
- EXP() – Exponential
- IM() – Imaginary part of a complex input. Output is real.
- KFACTOR() – Stability factor accepting 4 complex inputs (generally representing S11, S12, S21, and S22).
KFACTOR(Tr1,Tr2,Tr3,Tr4) produces:

$$\frac{1 - |Tr1|^2 - |Tr4|^2 + |Tr1 \cdot Tr4 - Tr2 \cdot Tr3|^2}{2|Tr2 \cdot Tr3|}$$

Output is real.

Equation 11-1.

- LN() – Natural log; standard branch cut
- LOG10() – Log base 10; standard branch cut
- MAG() – Magnitude accepting complex input (same as ABS). Output is real.
- MAX() – Maximum value of the MAGNITUDE of the variable selected. (Note that this updates only after a sweep completes so there may be a one sweep delay until the value propagates to a plotted equation). Output is real.
- MAX_HOLD() Accumulates maximum value of the MAGNITUDE of the argument sweep-to-sweep. The process is reset by clearing the equation or turning inter-trace math off. (Note that this updates only after a sweep completes so there may be a one sweep delay until the value propagates to a plotted equation). Output is real.
- MEAN() – Average value in a complex sense; (note that this updates only after a sweep completes, so there may be a one sweep delay until the value propagates to a plotted equation)
- MEDIAN() – Median value of the MAGNITUDE of the argument; (note that this updates only after a sweep completes, so there may be a one sweep delay until the value propagates to a plotted equation). Output is real.
- MIN() – Minimum value of the MAGNITUDE of the argument ... (note that this updates only after a sweep completes, so there may be a one sweep delay until the value propagates to a plotted equation). Output is real.
- MIN_HOLD() – Accumulates maximum value of the MAGNITUDE of the argument sweep-to-sweep. The process is reset by clearing the equation or turning inter-trace math off. (Note that this updates only after a sweep completes, so there may be a one sweep delay until the value propagates to a plotted equation). Output is real.
- MRKX() – Readout of active marker on entered trace, x-value. If no marker is on, a 0 will be returned. If more than one marker is on, the active marker will be used. Output is real. Since this function relies on a trace marker value, the argument can be ONLY a trace and not a function involving a trace.
- MRKY() – Readout of active marker on entered trace, y-value. If no marker is on, a 0 will be returned. If more than one marker is on, the active marker will be used. Since this function relies on a trace marker value, the argument can be ONLY a trace and not a function involving a trace.

- MU() – mu stability factor accepting 4 complex inputs (generally representing S11, S12, S21, and S22). MU(Tr1,Tr2,Tr3,Tr4) produces:

$$\frac{1 - |Tr1|^2}{|Tr1 - Tr4^*(Tr1 \cdot Tr4 - Tr2 \cdot Tr3)| + |Tr2 \cdot Tr3|}$$

(where the * denotes conjugate)

Output is real.

Equation 11-2.

- PHASE() – Same as ANGLE but degree output. Output is real.
- POW(z,n) – Raises a complex variable z to the nth power. n is a scalar.
- RE() – Returns real part of a complex input. Output is real.
- REWRAP() – Rewraps phase of a complex variable when range was truncated (often by a power function). The calculation is based on slope of low frequency data.
- SDEV() – Standard deviation of input data. This is evaluated only at sweep completion, so there may be a one sweep delay for values to propagate to a displayed equation. This calculation is based on the equation below where N is the number of points. Note that the output is real.

$$SDEV = \sqrt{\frac{\sum_{k=1}^N |y_k - MEAN|^2}{N - 1}}$$

Equation 11-3.

- SIN() – Sine. Note that this function will accept complex inputs and treat them as such. Commonly one would use this function only with a formatted trace set up for phase and then multiplied by pi/180 to convert to radians.
- SQRT() – Square root; standard branch cut
- TAN() – Tangent. Note that this function will accept complex inputs and treat them as such. Commonly one would use this function only with a formatted trace set up for phase and then multiplied by pi/180 to convert to radians.
- XAXISARRAY() – Generates the vector corresponding to the current sweep variable. Output is real.

11-7 Markers Overview

The ShockLine VNA provides up to thirteen markers per trace of which twelve can be direct markers and one a reference marker. Each marker can be individually controlled on/off and positioned as required. If the reference marker is off, each marker provides measurement data based on its display position. If the reference marker is on, each marker provides differential measurement data based on its position relative the reference. Other functions for display options and various types of single-peak search are available.

Marker Button Label Changes

The labels for marker buttons 1 through 12 change depending on whether they are on or off and whether the Ref. Mkr function (described below) is on or off.

Marker Unit Changes

The marker units change depending on the selected instrument sweep setting on the SWEEP TYPES menu and settings on the DOMAIN and RANGE menus:

- Frequency Sweep:
 - Marker units set to frequency (GHz, MHz, kHz, Hz)
- Segmented Sweep (Frequency-Based):
 - Marker units set to frequency (GHz, MHz, kHz, Hz)
- Segmented Sweep (Index-Based):
 - Marker units set to Index number.
- Power Sweep (CW Frequency):
 - Marker units set to power (dBm)

Reference Marker OFF or On

If Ref. Mkr is set to OFF, the label is formatted as:

- Mkr # [OFF] if the marker is off (where # is the marker number).
- Mkr # [ON] if the marker is on.
- For example, Marker 1 would be labeled either Mkr #1 [OFF] or Mkr #1 [ON].

If Ref. Mkr. is set to ON, the label is formatted as:

- Mkr#-Ref [OFF] if the marker is off.
- Mkr#-Ref [ON] if the marker is on.
- For example, Marker 1 would be labeled either Mkr#1-Ref [OFF] or Mkr#1-Ref [ON].

Turning Individual Markers Off and On

The MARKERS [1] menu described below is shown with Marker 1 (Mkr 1) through Marker 4 (Mkr 4) turned off. Individual markers can be turned off manually by clicking their buttons.

Turning All Markers On

All markers can be turned on either manually one-by-one (as above) or at the MARKERS [2] menu, by clicking the All Markers On button.

Navigation

MAIN | Markers | MARKERS | More Markers | MARKERS [2] | All Markers On

Note that selecting Inductance/Capacitance on the Smith (Impedance) menu enables marker Inductance or Capacitance measurement readout.

Turning All Markers Off

All markers can be turned off either manually one-by-one or at the MARKERS [2] menu, by clicking the All Markers Off button.

Navigation

- MAIN | Markers | MARKERS [1] | More Markers | MARKERS [2] | All Markers Off

Naming Conventions for Marker Buttons and Toolbars

The following conventions are used to label the marker buttons and toolbars in this section.

Marker Buttons

- Mkr # [Ref] [OFF/ON] is used for all button names (where # is the number of the marker).
- For example, Mkr1 [Ref] [OFF/ON] is used for the Marker 1 button when it is labeled Mkr 1 [OFF], Mkr 1 [ON], Mkr1-Ref [OFF], or Mkr1-Ref [ON].

Marker Toolbars

- Mkr # [Ref] [ON] is used for all marker toolbars (where # is the number of the marker).
- For example, Mkr1-[Ref] [ON] is used for the Marker 1 toolbar when it is labeled Mkr 1 [ON] or Mkr1-Ref [ON].
- Note the marker must be on for the toolbar to be available.

Position Marker(s)

A single marker or an array of marker data displays can be repositioned with a drag/drop within the signal response trace display. See [Figure 11-11 on page 11-18](#). Each marker can be individually controlled on/off and positioned as required on the signal response display.

If the reference marker is off, each marker provides measurement data based on its display position. If the reference marker is on, each marker provides differential measurement data based on its position relative the reference.

The marker(s) can be repositioned while using any parameter setup menu. Note that the marker data display placement area on the main display window may be limited if the detachable trace view windows in use are smaller in size than then the main display window.

The example below [Figure 11-11](#), depicts a two trace display. On the top trace display, the individual marker [9] is selected, and repositioned. In the bottom trace, the marker data display is repositioned

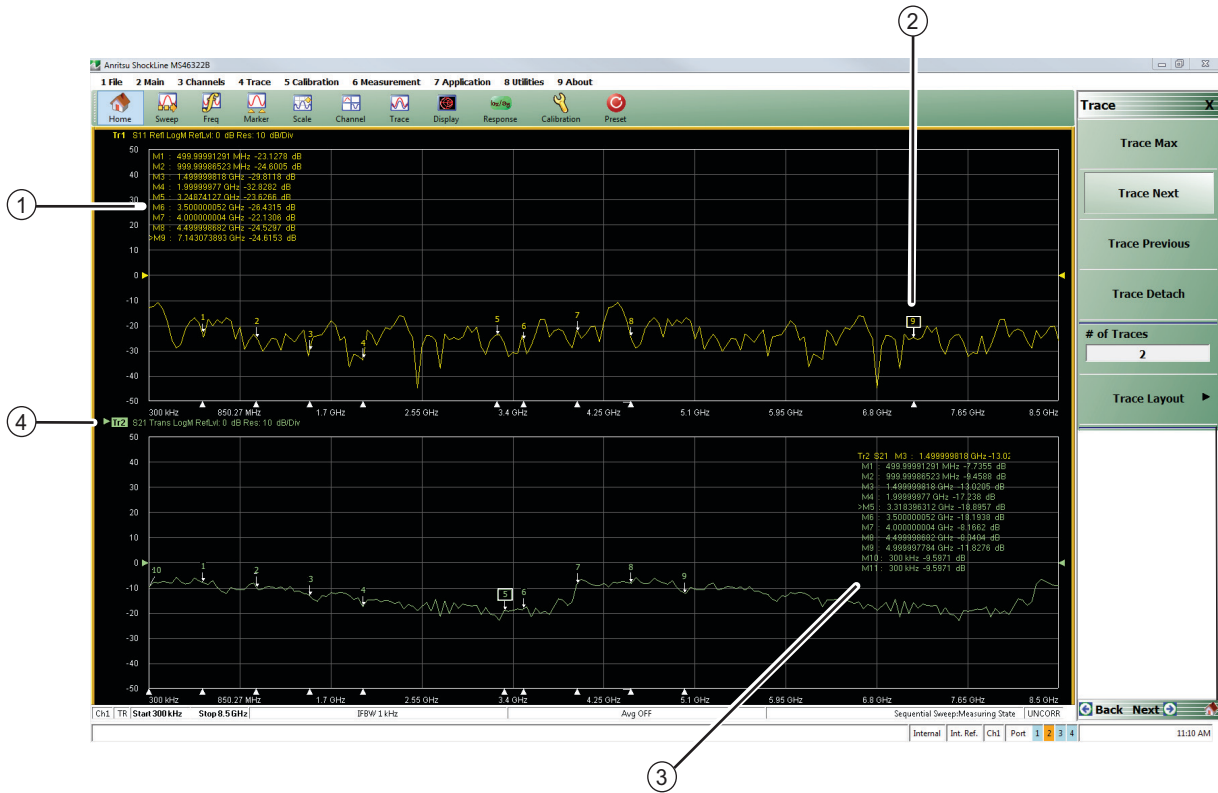

- | | |
|---|---|
| 1. Trace 1 marker data display with nine active markers | 3. Trace 2 marker data display with 11 active markers repositioned by click-drag-drop |
| 2. Trace 1 marker with a single selected marker [9] repositioned by click-drag-drop | 4. Highlighted active trace. |

Figure 11-11. Marker Data Display Drag-Drop

11-8 Hold Functions

Hold events and triggering events are per-channel. These menus are shown in [Figure 11-12](#) for hold events. The HOLD FUNCTIONS menu is available from the SWEEP SETUP menu.

- MAIN | Sweep | SWEEP SETUP | Hold Functions | HOLD FUNCTIONS

.Selecting Hold Conditions provides a toggle for RF on or off.



Figure 11-12. HOLD FUNCTIONS Menu

11-9 Overview of Limit Lines

There are a number of relatively simple measurement topics that require some comment but are not large topics by themselves. These issues have been grouped into this miscellaneous section to ensure that the information is readily available. These topics include:

- Limit lines: Setup tasks and test functionality
- Ripple Limit: Setup tasks and test ripple tolerance
- Averaging and smoothing: Functions and their effects on measurements

11-10 Limit Lines

Limit lines are a powerful tool to help quickly compare a set of measured DUT data against specifications or expectations. All limit testing is per trace and, depending on firmware version, limit testing may only be available on rectilinear graph types. Upper and lower limits on any parameter may be set and these may be separated into many frequency bands. There is a limit of a total of 50 segments (upper and lower combined) per trace. The main limit line menu is shown in [Figure 11-13](#).

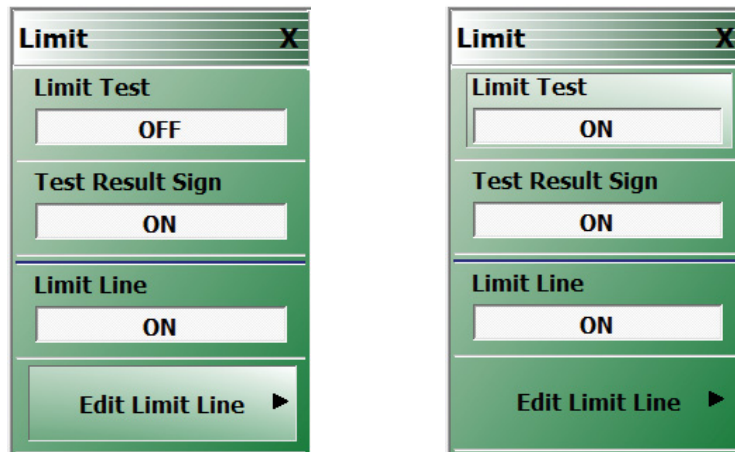

Figure 11-13. LIMIT Menu - Various Functions Toggled ON or OFF

The toggle buttons on the top level of this menu are straightforward:

Limit Test

The Limit Test button enables comparison of the data to the limit lines existing (this is per trace). The results of the test (pass or fail) will appear in the upper right corner (see [Figure 11-16](#)) of the graph for that trace.

Test Result Sign

The Test Result Sign button enables a large graphic displaying the pass/fail result. This will be in the middle of the screen and is visible from a large distance. The Limit Test must be on for this sign to appear. If any limit tests fail, the large fail sign will appear with a notation of which channel has failed. If the Test Result Sign function is used with both Limit lines and Ripple limit lines, the test result will be a logical OR between both limit line values meaning if either limit line fails, the FAIL sign will result.



Figure 11-14. Pass and Fail Signs Configured by the LIMIT Menu

Limit Line

Displays the current limit lines on the data graph. The limit lines will appear in red. Failing points are marked with a red dot.

Limit Fail Signal

Determines the state of the external limit status bit for a fail condition (see next item). High or Low (in a 3.3V logic sense).

Editing Limit Lines

The editing of the limit lines is controlled on the one submenu and that is shown in [Figure 11-15](#). When entering this menu, the limit line table will appear at the bottom of the screen (not unlike the multiple source and segmented sweep tables). Initially, the table will often be empty. If a limit line set was created on another trace, those values may appear here but they may be cleared or edited. The limit line tables may be saved and recalled separately using this menu (much like segmented sweep tables) or they may be saved and recalled as part of the global setup (use commands under the File menu to do this).

Edit Limit Line Menu

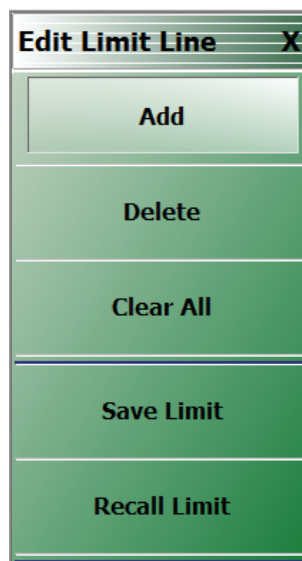

Figure 11-15. EDIT LIMIT LINE Menu

An example limit line table is shown in [Figure 11-16](#) using two upper limit segments and two lower limit segments. For each segment, a number of things need to be entered: Upper or lower: Use the pull-down to indicate if it is an upper limit or lower limit. Another option on the pull-down is “off” to enable suspension that segment.

X1 and X2

The constraints of the segment in the X-direction. Usually this variable will be frequency (segmented or linear frequency sweeps) but it could be time (time domain) or power (power sweep). If two segments cover the same frequency range (or portions thereof), the first segment will have precedence.

X1 (Actual) and X2 (Actual) (Read-only)

The X1 (Actual) and X2 (Actual) columns indicate the actual X1 or X2 value selected by the instrument, based on the value entered by the user. This value indicates where the Limit Line is actually drawn on-screen, and the actual span used for judging pass/fail per point on a trace. User-entered X1 and X2 values for Limit Line Segments are rounded down to the nearest actual data point

Y1 and Y2

The constraints of the segment in the Y-direction. These will have units of the graph type for the active trace (dB in the examples here).

	Type	X1	X1 (Actual)	X2	X2 (Actual)	Y1	Y2	X Offset	Y Offset
1	Upper	30 MHz	300 kHz	7 GHz	6.970054 GHz	9.8 dB	9.8 dB		
2	Lower	300 kHz	300 kHz	8.5 GHz	8.5 GHz	9.8 dB	9.8 dB		
3	Lower	3 MHz	300 kHz	4 MHz	300 kHz	9.8 dB	9.8 dB		
4	Upper	5 MHz	300 kHz	10.5 MHz	300 kHz	9.8 dB	9.8 dB		

Figure 11-16. Limit Line Table

The X offset and Y offset values allow one to shift both indices in a row by a constant amount. This can be useful in copying multiple rows and, for example, incrementing by a fixed frequency offset.

11-11 Ripple Limit Lines

Limit lines are a powerful tool to help quickly compare a set of measured DUT data against specifications or expectations. All limit testing is per trace and, depending on firmware version, limit testing may only be available on rectilinear graph types. Upper and lower limits on any parameter may be set and these may be separated into many frequency bands. There is a limit of a total of 50 segments (upper and lower combined) per trace.

An adequate number of points must be used for effective use of this function. The ripple line limit will be automatically placed on the ripple based on the frequency start and stop set and ripple value. The ripple value is divided between the upper and lower limit when set. The main RIPPLE (Limit) LINE menu is shown in [Figure 11-17](#)

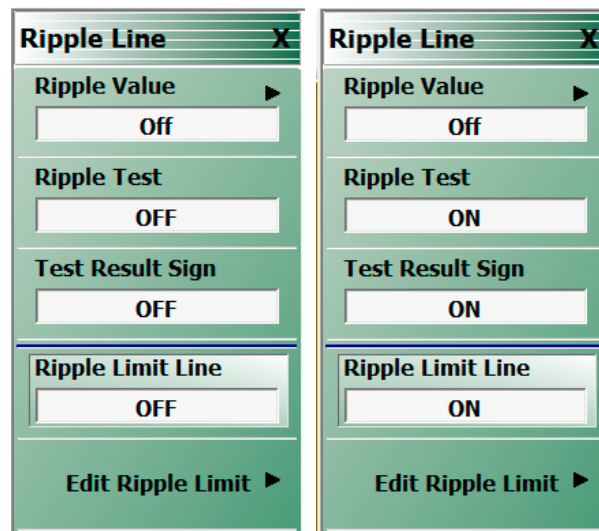

Figure 11-17. RIPPLE LINE Menu - Various Functions Toggled ON or OFF

The toggle buttons on the top level of this menu are:

Ripple Value

The Ripple Value button allows the user to set the ripple value setting to Absolute Value or Margin. Absolute Value is the between the minimum and maximum of the ripple while Margin is the difference relative within the ripple limit line.

Ripple Test

The Ripple Test button enables comparison of the data to the limit lines existing (this is per trace). The results of the test (pass or fail) will appear in the upper right corner of the graph for that trace.

Test Result Sign

The Test Result Sign button enables a large graphic displaying the pass/fail result. This will be in the middle of the screen and is visible from a large distance. The Limit Test must be on for this sign to appear. If any limit tests fail, the large fail sign will appear with a notation of which channel has failed. If the Test Result Sign function is used with both Limit lines and Ripple limit lines, the test result will be a logical OR between both limit line values meaning if either limit line fails, the FAIL sign will result.

Ripple Limit Line

Displays the current ripple limit lines on the data graph. The limit lines will appear in red. Failing points are marked with a red dot.

Limit Fail Signal

Determines the state of the external limit status bit for a fail condition (see next item). High or Low (in a 3.3V logic sense).

Editing of Ripple Limit Lines

The editing of the Ripple Limit lines is controlled on the one submenu and that is shown in [Figure 11-17](#). When entering this menu, the Edit Ripple Limit Line table will appear at the bottom of the screen (not unlike the multiple source and segmented sweep tables). Initially, the table will often be empty. If a limit line set was created on another trace, those values may appear here but they may be cleared or edited. The limit line tables may be saved and recalled separately using this menu (much like segmented sweep tables) or they may be saved and recalled as part of the global setup (use commands under the File menu to do this).

An example ripple limit line is shown in [Figure 11-19](#) using two frequency segments. The ripple value determines the ripple upper and lower limits. For example, the 300 kHz to 5 GHz start and stop range will have an upper and lower limit of 1 dB about the ripple.

	Active	Start	Stop	Ripple
1	On	300 kHz	5 GHz	2 dB
2	On	5 GHz	8.5 GHz	1 dB

Figure 11-18. Ripple Limit Line

Response Menu

These are selectable on the response menu as shown in Figure 11-19 below. The submenu allows a choice of which port is driving during that particular analog in measurement. This port selection may be important particularly with the use of external power detectors.

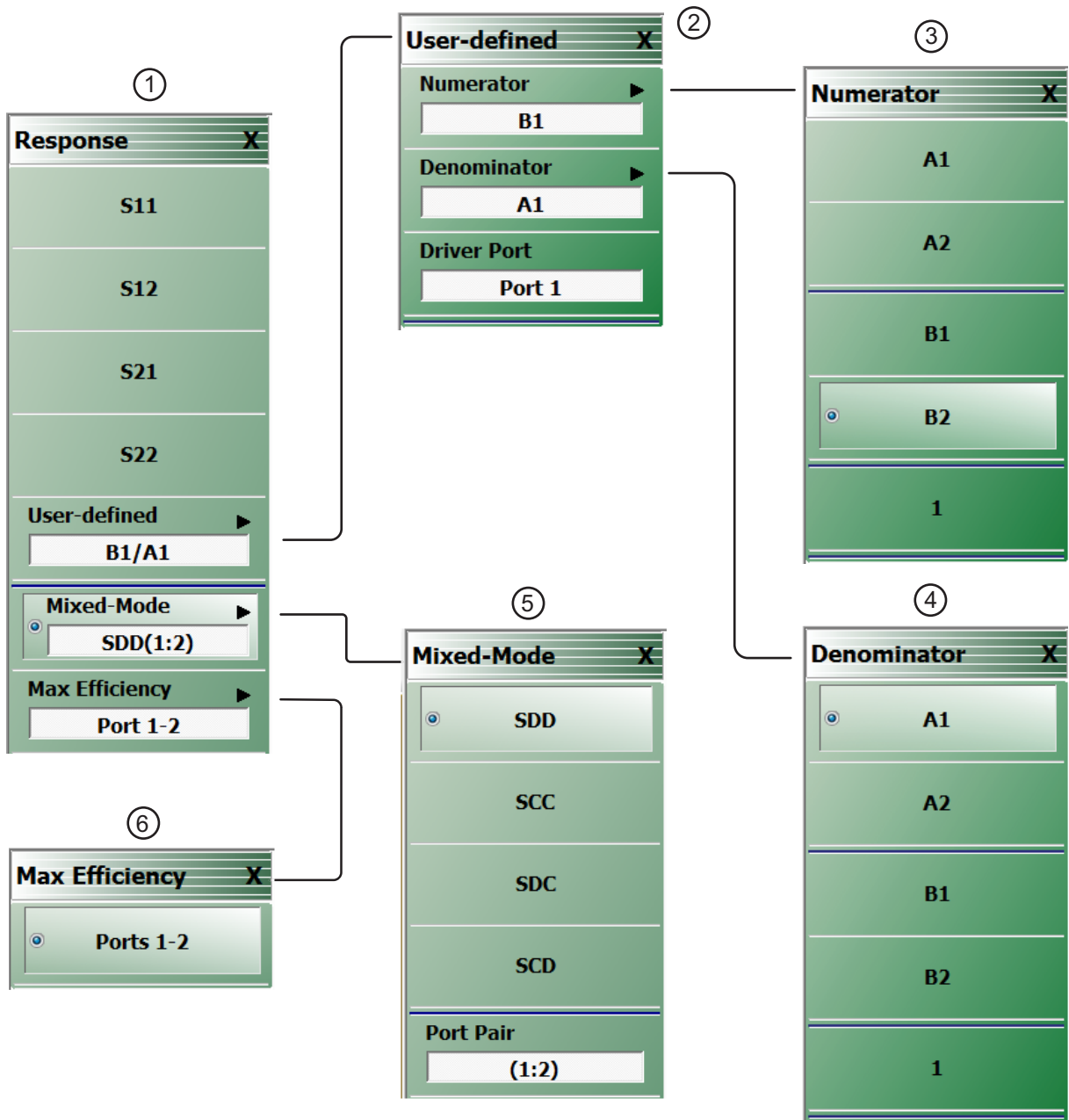

1. RESPONSE menu

2. USER-DEFINED menu

3. MIXED-MODE menu

4. NUMERATOR menu

5. DENOMINATOR menu

6. MAX EFFICIENCY menu

Figure 11-19. RESPONSE Menu and Submenus

11-12 Averaging and Smoothing

Overview

Averaging and smoothing are covered to a considerable extent in the operations manual but there are some measurement-related impacts that should be discussed in this section. The control menu is repeated in [Figure 11-20](#) for reference.

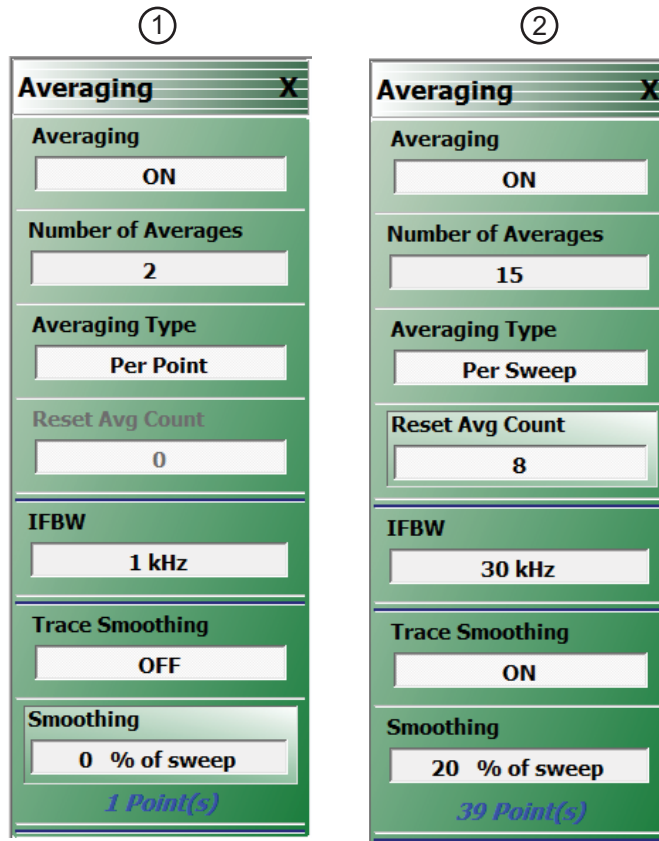

1. IFBW is set to 1 kHz and Trace Smoothing set to OFF (at left).

2. IFBW is set to 30 kHz, Trace Smoothing set to ON with Smoothing applied to 20% of the sweep (at right).

Figure 11-20. AVERAGING Menu - Both menus show that averaging has been toggled on.

Averaging

The Averaging button toggles the function OFF and ON.

Avg. Factor - Number of Averages

The Avg. Factor (Averaging Factor) represents the number of measurements performed at each frequency point in the case of per-point averaging, and represents the number of sweeps averaged (in a running average sense) for per-sweep averaging.

Averaging Type

The Averaging Type button toggles between per-point and per-sweep averaging.

- **Per-Point Averaging**

Per-point averaging acquires additional samples at each frequency (or power) point and performs the averaging process at that time. In this sense, it is quite similar to an IFBW reduction (adding 10 per point averages is equivalent to a 10x reduction in IFBW). Since the time between sample acquisitions is small in this case, per point averaging works best at removing high rate noise.

- **Per-Sweep Averaging**

Per-sweep averaging averages a given frequency (or power) point's behavior on subsequent sweeps. This can be a very long time constant between samples (depending on sweep speed) so this type of averaging does best with low rate noise.

Per-sweep averaging is performed on a rolling basis. That is, if 10 per sweep averages are selected, the most recent sweeps are used to compute the result.

Since per-sweep averaging has a long time constant, setup changes or DUT changes can appear to have an odd effect. Powering down an active DUT, for example, may lead to an S21 display to slowly drift away since it takes some time for the gain change to work its way through the sweep count. If a setup or DUT change is made, it may be desirable to reset the averaging count.

IFBW

The Intermediate Frequency Bandwidth (IFBW) is allowed in the range of 10 Hz to 300 kHz on the MS46122A/B and MS46322A/B. At lower IFBW, additional per point averaging will have little effect.

At very low frequencies, where the IFBW may be on the order of the system frequency, there could be measurement issues. By default, the IFBW will be limited at system frequencies below 3 MHz although this can be overridden under the System menu.

Trace Smoothing

Trace smoothing is toggled OFF and ON by this button. Trace smoothing performs a weighted averaging around each frequency point using a window size set by the percentage of smoothing. Since this process combines data at different frequency points, it should be used with care since it can remove valid frequency response information.

Averaging and Smoothing Conclusions

In time domain, averaging and IFBW apply to the basic frequency domain data. Smoothing applies to the time domain data.

Chapter 12 — Measurement – Time Domain (Option 002)

12-1 Chapter Overview

This chapter provides time domain measurement guidelines and procedures. General descriptions, key concepts, and example procedures are presented for time domain measurement modes of low pass, bandpass and gating.

12-2 Introduction

The time domain option offers the ability to transform the native frequency domain data of the MS46122A/B and MS46322A/B into time domain information for TDR-like displays, distance-to-fault analysis, and general spatial-based circuit and network troubleshooting. Uses for time domain include:

- Identifying the location of significant mismatches/discontinuities in a launch structure in a fixture or PC board
- Finding and quantifying defects in a cable assembly
- Identifying the characteristics of a discontinuity (inductive or capacitive) in a transition within a fixture or on-wafer
- Determining semi-quantitatively the impedance levels in a cascaded series of transmission lines.

There are a significant number of choices in how to configure the transformations that this section will cover. To begin, time domain is a per-trace invocation so that frequency domain and time domain traces can be freely mixed on any response parameter. Note that since there is a single x-axis readout per channel, and it will be in the units of the active trace (either frequency or time range, not both at the same time will be displayed). Time domain and the TIME DOMAIN menu is accessed from the DISPLAY menu and its top level selections are shown in [Figure 12-1 on page 12-2](#).

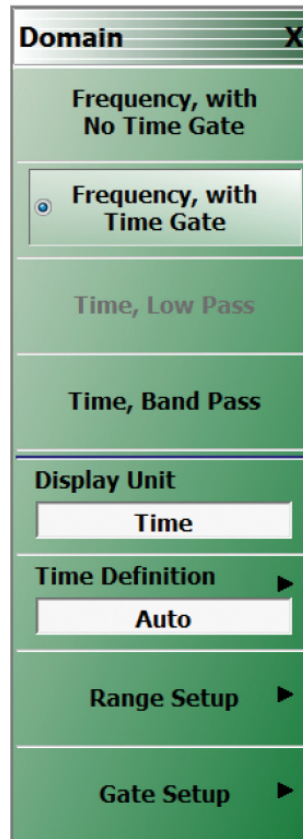

Figure 12-1. DOMAIN Menu - Top Level Domain Menu

12-3 Basic Time Domain Modes

The four basic modes of the Time Domain menu available from the Domain Menu [Figure 12-1, “DOMAIN Menu - Top Level Domain Menu”](#):

- **Frequency With No Time Gate**

This is the regular frequency sweep mode.

- **Frequency With Time Gate**

This is frequency domain data that has passed through time domain where a gate is applied to exclude certain data (such as to remove certain defects) before returning to the frequency domain.

- **Time, Low Pass**

A time domain mode where frequency content fairly close to DC is available (start frequency no more than about 10 step sizes). Step response (like a TDR) processing is available and resolution is better but this mode may not be available for all frequency lists. The selection will be greyed out if incompatible.

- **Time, Bandpass**

A time domain mode for any frequency list. Only impulse response can be displayed, defect identification tools are more limited, and resolution is a factor of 2 worse than in lowpass (for the same sweep width) but it can be used for any frequency sweep. This is the only choice in band-limited scenarios such as waveguide.

12-4 General Concepts

Chirp-Z Transform

The time domain functionality is provided by a chirp-Z transform (in most cases) of the available frequency domain data for that parameter. Since the transform simply treats the frequency domain values as input data, any parameter can be transformed. Unratioed parameters are less useful since they do not contain phase information that the transform relies upon.

The chirp-Z transform is, in a macro sense, very similar to the Fast Fourier Transform with the exception that the output range can be variable. This allows the ability to specify an arbitrary time range to look at while maintaining the desired point count. A different algorithm is used with dispersive media, such as waveguide and microstrip where the time-frequency relationship is more complex, but the functionality remains the same.

Defects as Impulse Functions in the Time Domain

Defects can be considered to be impulse functions in the time domain. This sum of impulses transforms to a sum of complex exponential in the frequency domain. While these produce the characteristic ripples seen in frequency domain data of mismatched systems, the frequency domain data can be hard to interpret as to the location of the defects causing the ripples. This is the value of a time domain analysis.

One-Way or Round Trip Time

One question that arises is whether the time (or distance) plotted represents a one-way or round trip time, particularly in the case of reflection measurements. The time definition menu, shown in [Figure 12-2 on page 12-3](#), controls this behavior. When in **Auto**, the system will always display one-way times and detects whether the measurement parameter is reflection or transmission to help sort that out. If using user-defined parameters or unusual loop-access configurations, going to manual control may be needed. The transform itself will generate a round-trip time for reflection and a one-way time for transmission without any intervention from the system.

The following menus are accessible through the Display sub-menus. Users can access these same features through the Measurement Setup dialog menu.

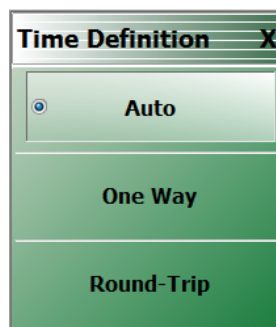

Figure 12-2. TIME DEFINITION Menu

12-5 Low Pass Mode

Low pass mode assumes the existence of data near DC which enables the ability to compute step responses and to create a pure real transform. While any graph type can be used (except Imaginary which would have a flat line), Real is sometimes the most valuable since information about the defect can be determined. An example plot showing a short at the end of a small transmission line length of approximately 100 ps appears in [Figure 12-3](#). Both the impulse response and step response are plotted on real graph types. Many aspects of this plot will be discussed in this section including the impulse and step presentation of the same data.

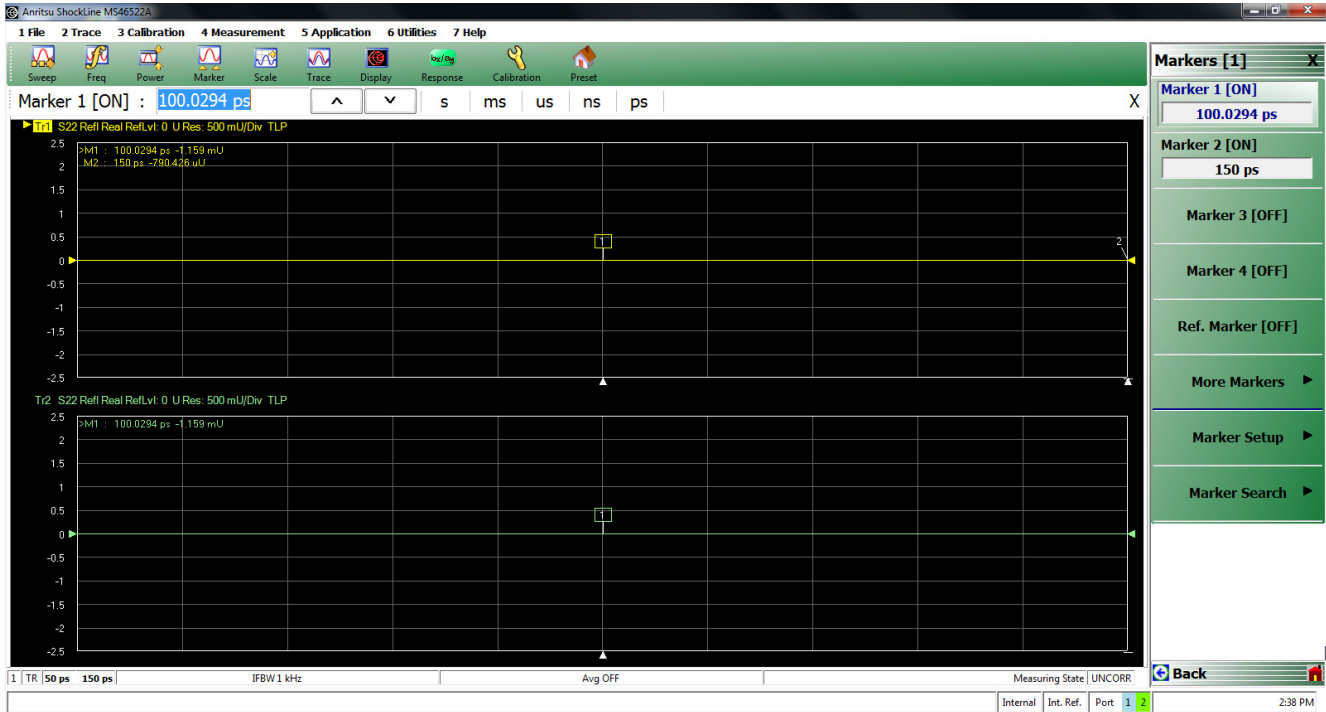

Figure 12-3. Example Low-pass Time Domain Plot

Many of the other submenus change slightly depending on which mode is selected so the remaining subsections will be partitioned according to the mode.

Range Setup Menu Functions

The Range Setup menu for low-pass time domain is shown in [Figure 12-4](#). The top button, Display Unit, toggles between Time and Distance and is a duplicate button to the Display Unit button on the TIME DOMAIN menu ([Figure 12-1](#)).

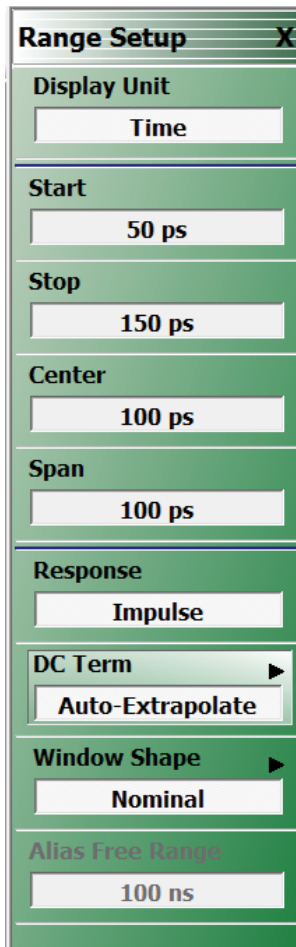

Figure 12-4. RANGE SETUP Menu - Time, Low Pass Domain

The fundamental output of the transform depends on the non-dispersive or dispersive nature of the media. In the case of non-dispersive media (to include coax), time is the fundamental output of the transform and distance is calculated using the media information on the measurement menu. In the case of dispersive media (waveguide or microstrip), distance is the fundamental output and time is calculated from that.

The **Start**, **Stop**, and **Center** buttons all invoke field tool bars that allow user-input for each value (in distance or time); with the **Span** button displaying the calculated result. There are few limits to what may be entered but extreme entries may not always be useful due to constraints of resolution and alias-free range. These limits are determined by the frequency list used as well as the window selected.

Resolution is interpreted as impulse width (the width of a singular defect) while alias-free range is the maximum time range that can be studied before defects start repeating themselves (due to the cyclical nature of the transform). To help, the resolution (impulse width) is displayed as a read-only variable on the main time domain menu ([Figure 12-1](#)) and the alias-free range is displayed on this range menu as a read-only variable.

The response choice is either Impulse or Step. The step response, which allows a TDR-like display is simply an integration of the impulse response which is the natural output of the transform. Normally, this integration begins at the start time used in the current range (and continues to the stop time). This is advantageous when using results for certain de-embedding activities. It can, however, be confusing if one zooms into a region of impedance different from the reference impedance since the integration would not capture the transition. For this reason, there is the selection available to start the integration at 0 (regardless the range setting). The integrated result will be mapped back into the current start-stop range using interpolation with the linear value set to zero at negative times. If the stop time is also negative, the integrated result will all be near zero.

Note that the integration for step response also requires an initial integration value and this comes from the network's DC response. Since the ShockLine MS46122A/B-10 and MS46322A/B-10 VNAs cannot get all the way to DC, some additional information is needed to perform this integration. To see this consider:

$$\begin{aligned} \text{ImpulseResponse} &= \mathfrak{S}^{-1}\{X(\text{DC}) + \{X(\text{sweepRange})\}\} \\ \text{ImpulseResponse} &\approx A \cdot X(\text{DC}) + \mathfrak{S}^{-1}\{X(\text{sweepRange})\} \\ \text{StepResponse} &= \int_0^t [A \cdot X(\text{DC}) + \mathfrak{S}^{-1}\{X(\text{sweepRange})\}] dt \end{aligned}$$

Equation 12-1

DC Term Menu

Note The term menu is only available in low pass time domain mode.

Since the DC value ends up being integrated from time 0 (zero), the value used here is quite important and the choices to compute this value are shown in [Figure 12-5](#). The default choice is to allow the system to auto-extrapolate from existing frequency data to estimate the DC value.

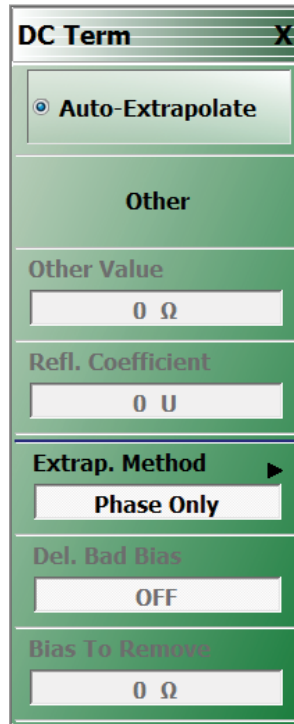

Figure 12-5. DC TERM Selection Menu

There are options on how the extrapolation is done, as shown in [Figure 12-6](#).

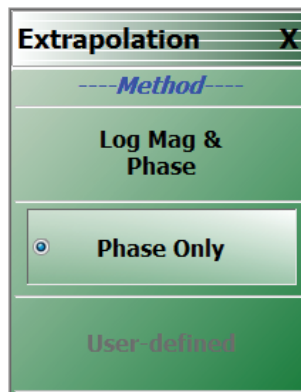

Figure 12-6. The DC Term EXTRAPOLATION Menu

The default method, Mag-Phase, extrapolates both portions as would be expected and is energy-conserving. For cases where the start frequency is low and the DUT loss changes slowly over frequency, sometimes the magnitude may be assumed constant and only the phase function need be extrapolated (most common with long cable assemblies). The other option allows a table of low frequency values to be entered (two-column, tab-delimited). If the DUT is well-known, extrapolation can be avoided altogether by entering the DC impedance.

Window Shape Menu

The last item on the Range Setup menu is the Window Shape selection button which displays the Window Shape submenu shown in [Figure 12-7](#).

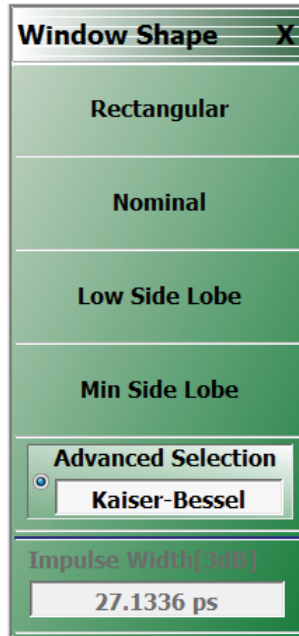

Figure 12-7. WINDOW SHAPE Menu

Since the frequency range of the VNA is finite, the frequency domain data will have a discontinuity at the stop frequency. This introduces side lobes in the time domain data that can obscure smaller defects and hamper separation of defects. The window provides some pre-processing of the frequency domain data to reduce the severity of the discontinuity and hence the side lobe level. This also reduces resolution but is unavoidable.

The Nominal window is the default and provides about half of the resolution of Rectangular (no window) but with an approximate 30 dB reduction in side lobe levels. The Nominal window is advised for most applications.

Since the window so strongly affects resolution, the Impulse Width display is repeated on this submenu to help determine the impact on the desired measurement.

An example of how the window shapes affect the impulse data (main lobe width and side lobe level being traded-off) is shown in Figure 12-8. Here the same data appears with the four different window selections. For this plot, data was saved to TXT files and plotted externally.

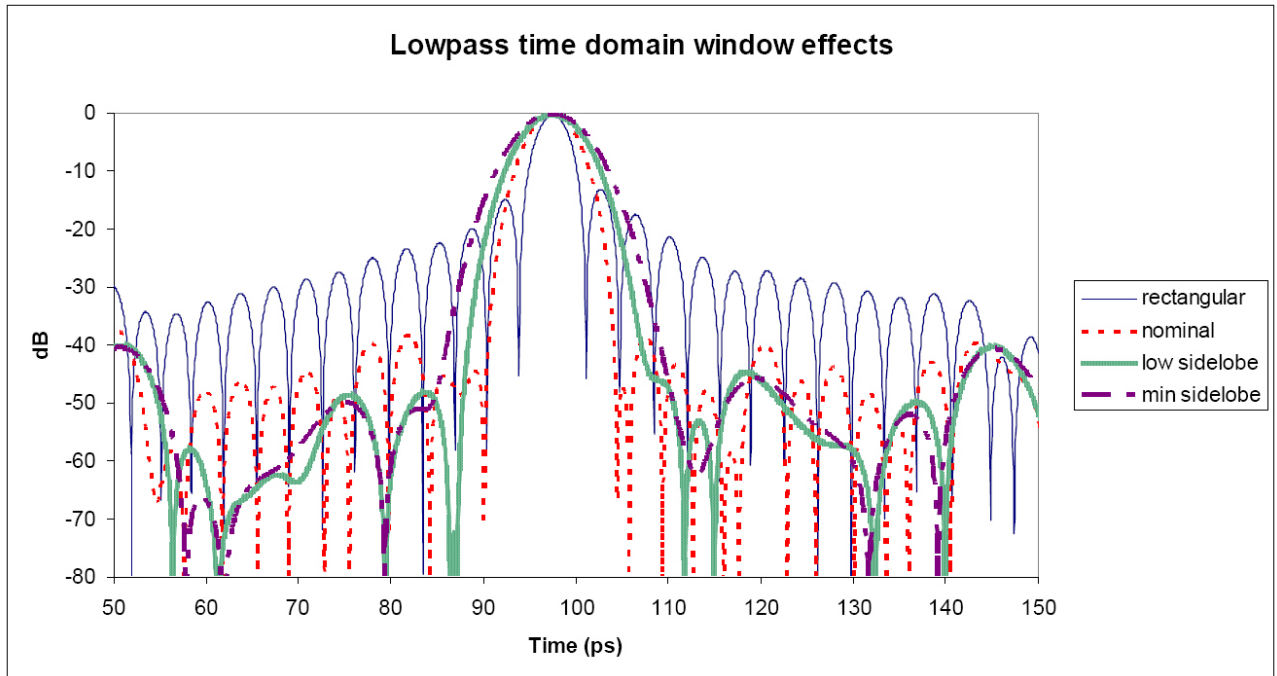

Figure 12-8. Effects of Window Shapes Plot

The Advanced Window selection button brings up the dialog shown in Figure 12-9 that has the previous four choices along with two new parameterized windows, Kaiser-Bessel and Dolph-Chebyshev.

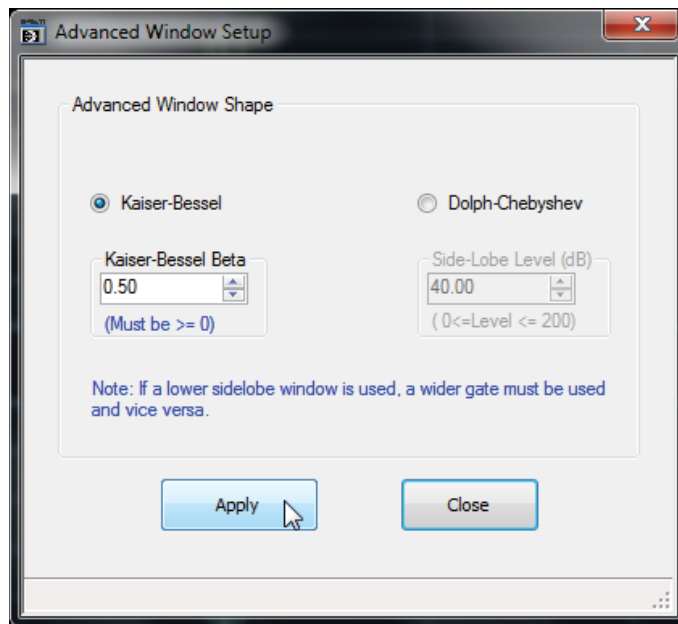

Figure 12-9. Advanced Window Setup Dialog

The dialog for advanced window setup makes two new window choices available (Kaiser-Bessel and Dolph-Chebyshev). The Apply button must be used for a radio-button selection to take effect.

These two new window types allow for a finer selection of the trade-off between side lobe level and resolution. For the Kaiser-Bessel window, a larger Beta value leads to lower side lobes, but a wider main lobe width (and hence poorer resolution). For the Dolph-Chebyshev window, the side lobe level is parameterized explicitly (in absolute dB) and a larger value leads to a wider main lobe width as well. The windows for two parameter values for each of these windows are shown in Figure 12-10 along with the rectangular window for comparison.

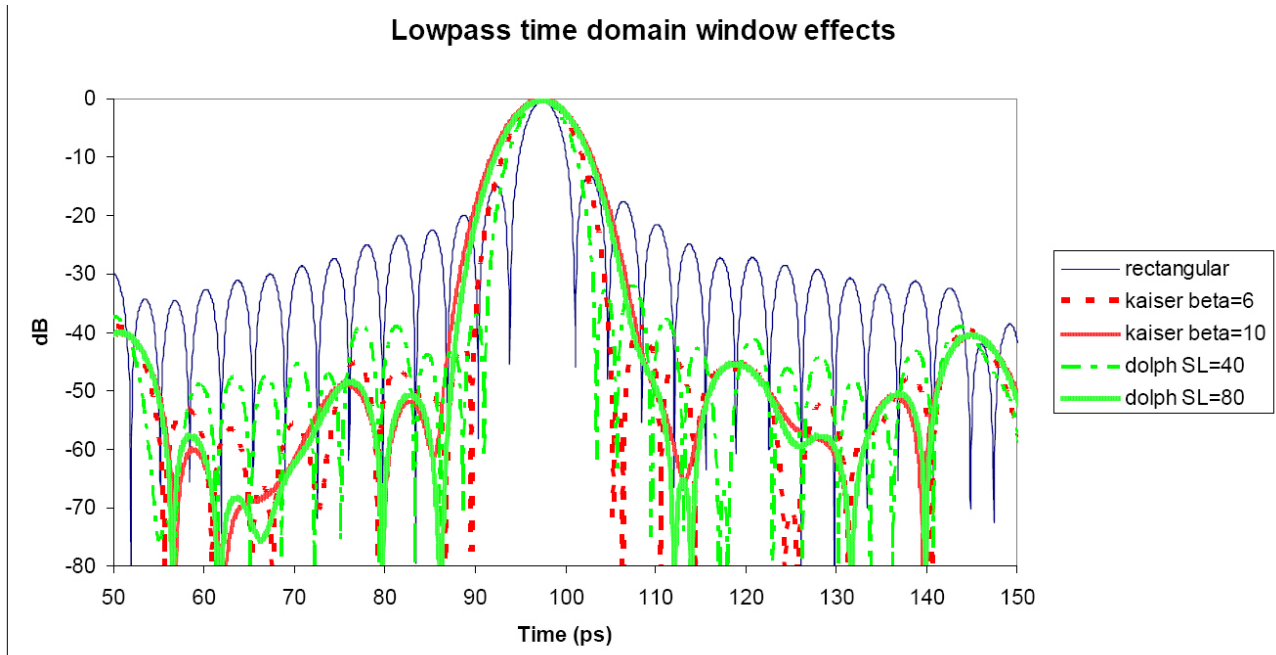

Figure 12-10. Effects of Window Shapes Plot with Advanced Windows Selection

The approximate relationship between these parameters and the main lobe width (null-to-null) is suggested in Figure 12-11. Here, everything is scaled relative to a rectangular window (a nominal window is at 2, a low side-lobe window is at 3, and a minimum side-lobe window is at 4 on this scale) and the y-axis is normalized relative to the lobe width of a rectangular window.

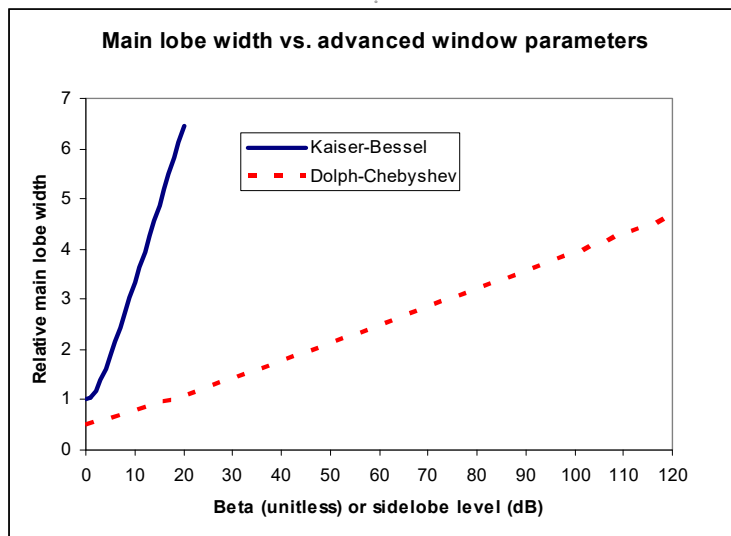

Figure 12-11. Comparison of Lobe Width vs. Window Parameters

12-6 Bandpass Mode

The Bandpass Time Domain mode is similar to low pass but a few menu items change. Any graph type can be used with bandpass mode but log magnitude and linear magnitude are the most common. The top level of the time domain menu is repeated in [Figure 12-12](#) for convenience. This menu level does not change between the time domain modes. An example measurement (of a short on a transmission line like in [Figure 12-2](#)) is shown in [Figure 12-17](#). Here, a real and imaginary plot is shown to illustrate the difference from the pure real low pass time domain result but this graph type is not commonly used in practice.

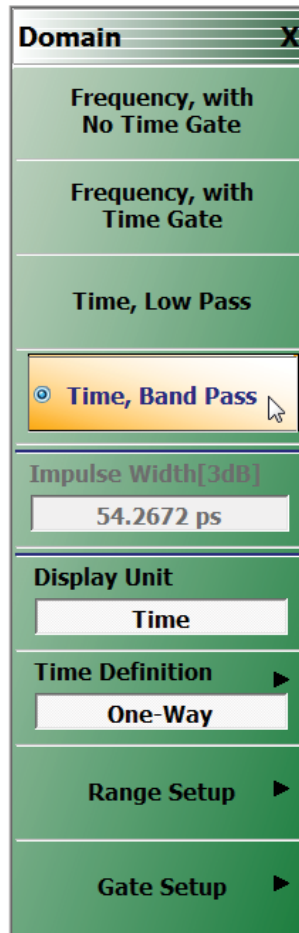

Figure 12-12. Top Level DOMAIN Menu - Time, Band Pass Selected

An example bandpass time domain plot is shown below for a short at the end of a transmission line. In a log magnitude display, there is a single impulse of approximately unity amplitude near the 100 ps mark.

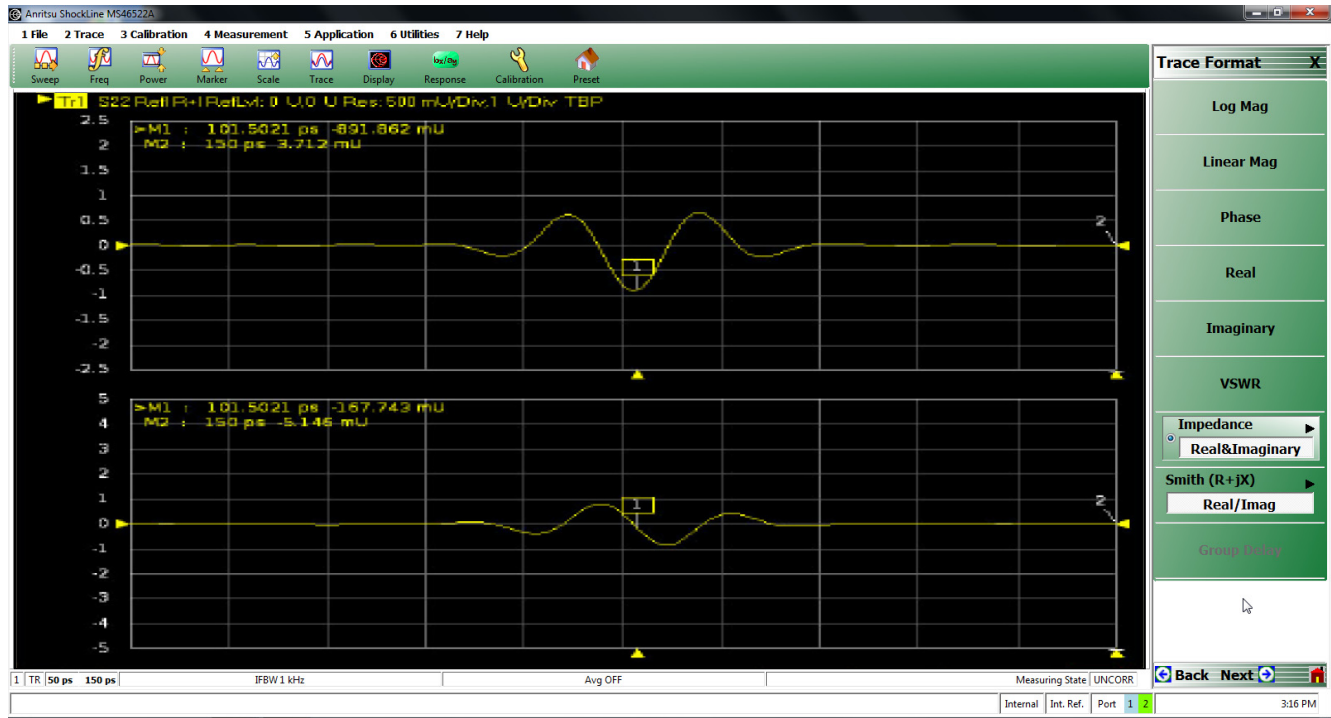

Figure 12-13. Example Band-pass Time Domain Plot

The range menu for bandpass mode is shown in [Figure 12-14](#). The differences here are that the response choice and DC terms are gone since they do not apply to this mode, and a new item appears: Phasor Impulse.

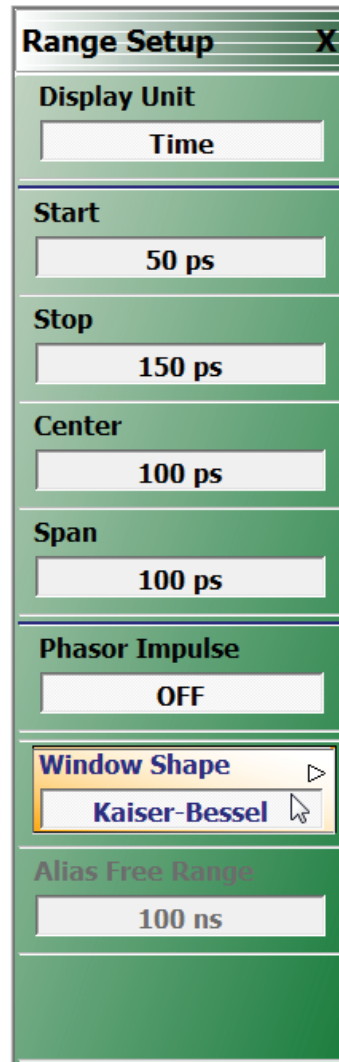

Figure 12-14. RANGE SETUP Menu for Bandpass Time Domain

In low pass mode, the sign of the data can be used to provide some hints as to the nature of the defect (inductive or capacitive). It is less obvious in bandpass mode since the time domain data is complex. A function termed Phasor Impulse Mode is an attempt to simulate the data reduction of low pass mode when operating in bandpass mode. It is only correct if the defect can be described by a single defect (a single complex exponential in the frequency domain). The range should be adjusted to have one peak on screen occupying a reasonable fraction of the span. The Phasor Impulse function processes this single peak to produce a pure real transform carrying sign information much like lowpass mode (positive for inductive, negative for capacitive).

The window shapes have the same effect as in low pass but the starting resolution is only half that of low pass (the window effects are multiplicative). The window effects are illustrated in Figure 12-15 and correspond to the measurement of Figure 12-13 on page 12-12, but expressed in log magnitude. Note the trade-off of side lobe height for main lobe width and that the lobe width is twice that for low pass (Figure 12-8 on page 12-9).

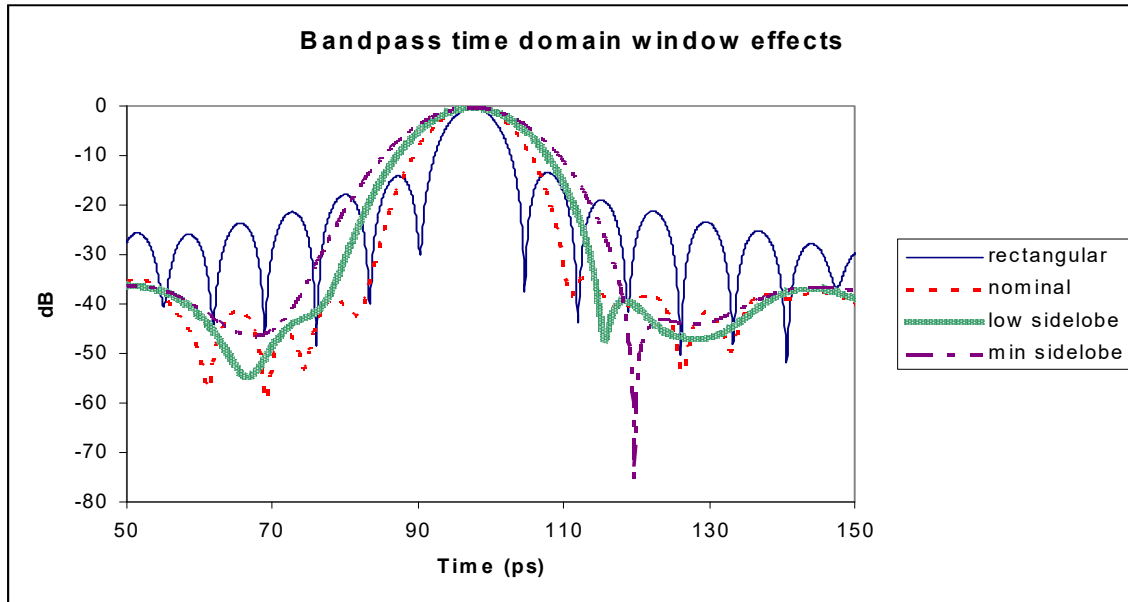

Figure 12-15. Window Effects in Bandpass Time Domain

As with lowpass time domain, the Advanced Windows are also available. Some example results are shown below compared to the rectangular window for a few parameter values.

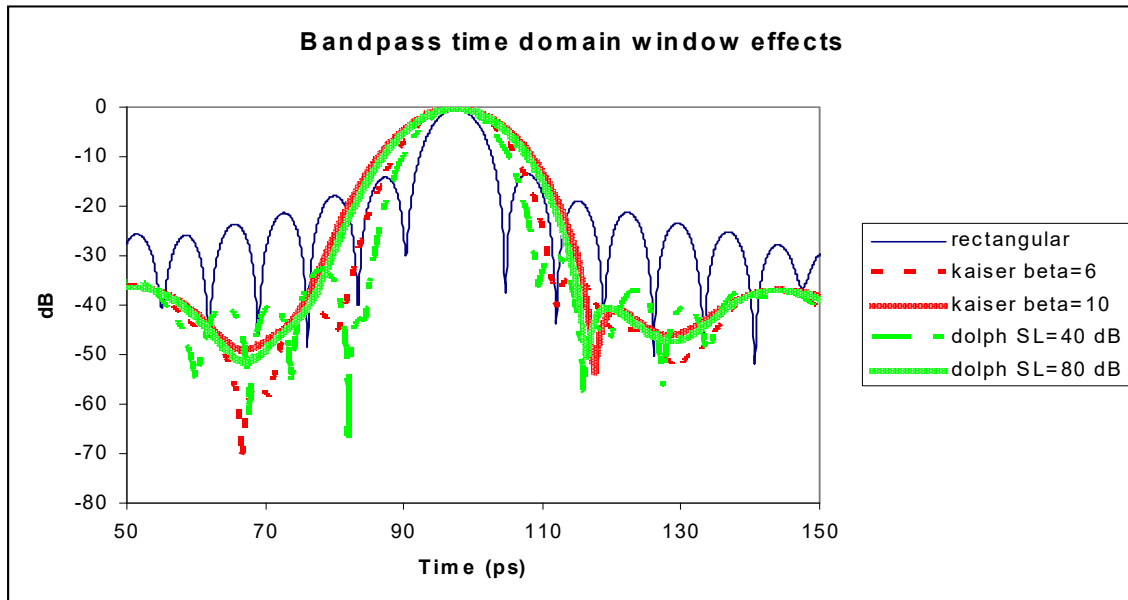

Figure 12-16. Window Effects in Bandpass Time Domain (advanced window types)

12-7 Gating

Both lowpass and bandpass work similarly with regards to gating. Gating is the process of selecting or deleting certain defects to study. This can be left in time domain but, more commonly, the gated results are fed back through the forward transform to get the frequency domain result corresponding to the modified defect scenario just created.

Gate Menu

The Gate menu looks much like the Range Menu. The Display Unit toggle button and Start, Stop, Center, and Span buttons (for the gate this time) control values as described in the sections above.

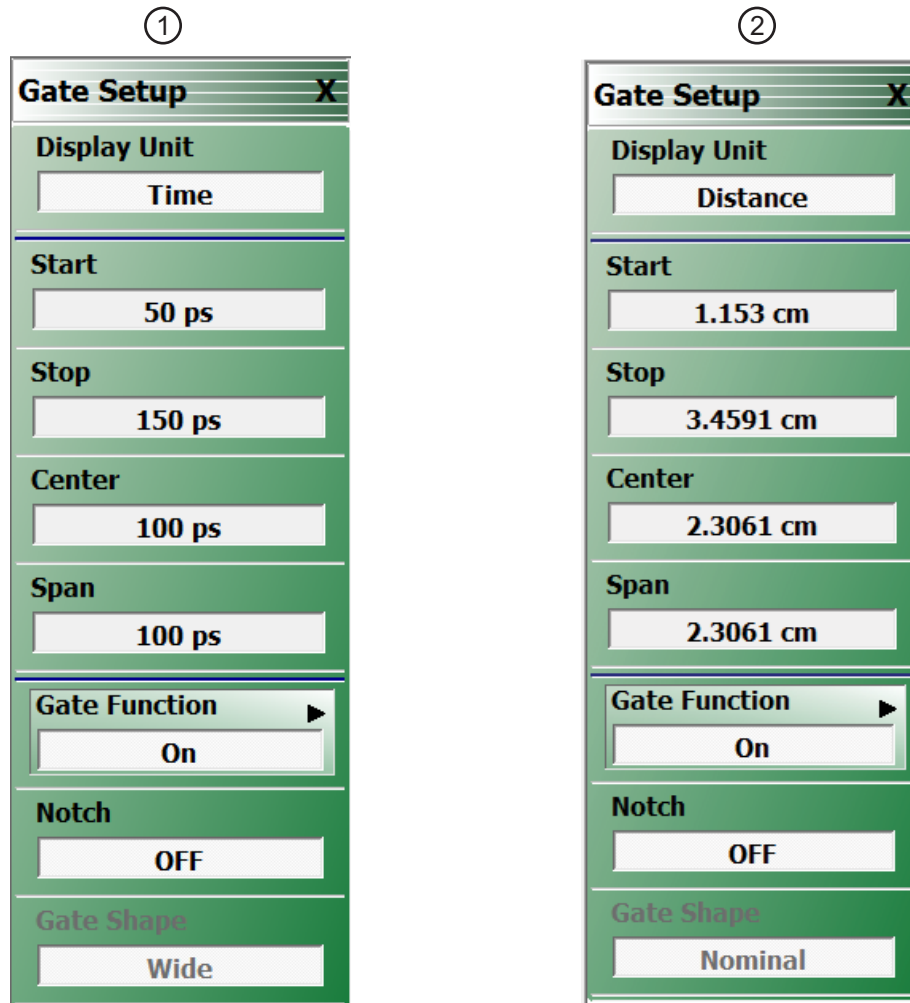

1. Time units (at left)

2. Distance units (at right)

Figure 12-17. GATE SETUP Menu

The Notch toggle selects the polarity of the gate. When notch is OFF, the gate will keep everything between start and stop. When notch is ON, the gate will reject everything between start and stop. The main submenu, Gate Function, is shown in [Figure 12-18](#).

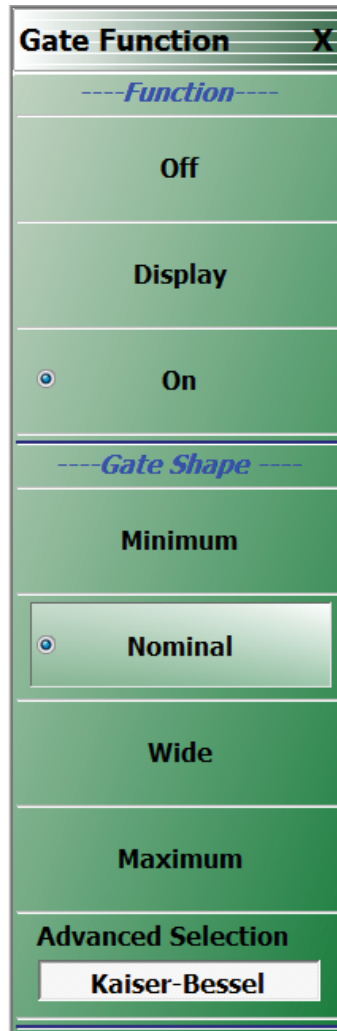

Figure 12-18. GATE FUNCTION Submenu

The default gate shape is nominal. By default, the gate is off. Selecting **Display** will allow the gate function to be drawn on screen (using the current graph type for the active trace). This can be helpful in visualizing what is being included in the gate. Turning gate on will apply the gate to the current time domain data.

The gate shape is analogous to the window selection. If the data was truncated with a sharp gate (minimum, akin to rectangular), maximum resolution is used determining the gate but ripple is introduced in the frequency domain. For more gradual gates, the resolution in separating defects decreases, but the size of the artifacts added to the frequency domain data decreases as well.

The window and gate shapes cannot be selected entirely independently since they interact through the transform. In particular, the use of a very sharp gate with a low side lobe window can lead to large errors. The allowed combinations are shown in the table below. If an invalid combination is selected, the variable not being currently modified will be changed to the nearest valid value.

With the advanced gates and windows, selections are not precluded although substantial errors can result if values are chosen without caution. If a more aggressive window is chosen (larger beta or side-lobe level), then the gate must be wider (wide or maximum; larger beta or side-lobe level).

Table 12-1. Window Type and Gate Shape Allowed Combinations

Window/Gate	Minimum	Nominal	Wide	Maximum
Rectangular	OK	OK	OK	OK
Nominal	OK	OK	OK	OK
Low side lobe	No	OK	OK	OK
Minimum side lobe	No	No	OK	OK

DUT Example - Gate and Window Nominal

To work through an example, a DUT consisting of a short at the end of a slightly mismatched transmission line is used. It is desired to examine the short more closely in frequency domain, excluding the effects of the transmission line. In [Figure 12-19](#), the gate is in display mode surrounding the desired reflection. Both gate and window are set to nominal in this case.

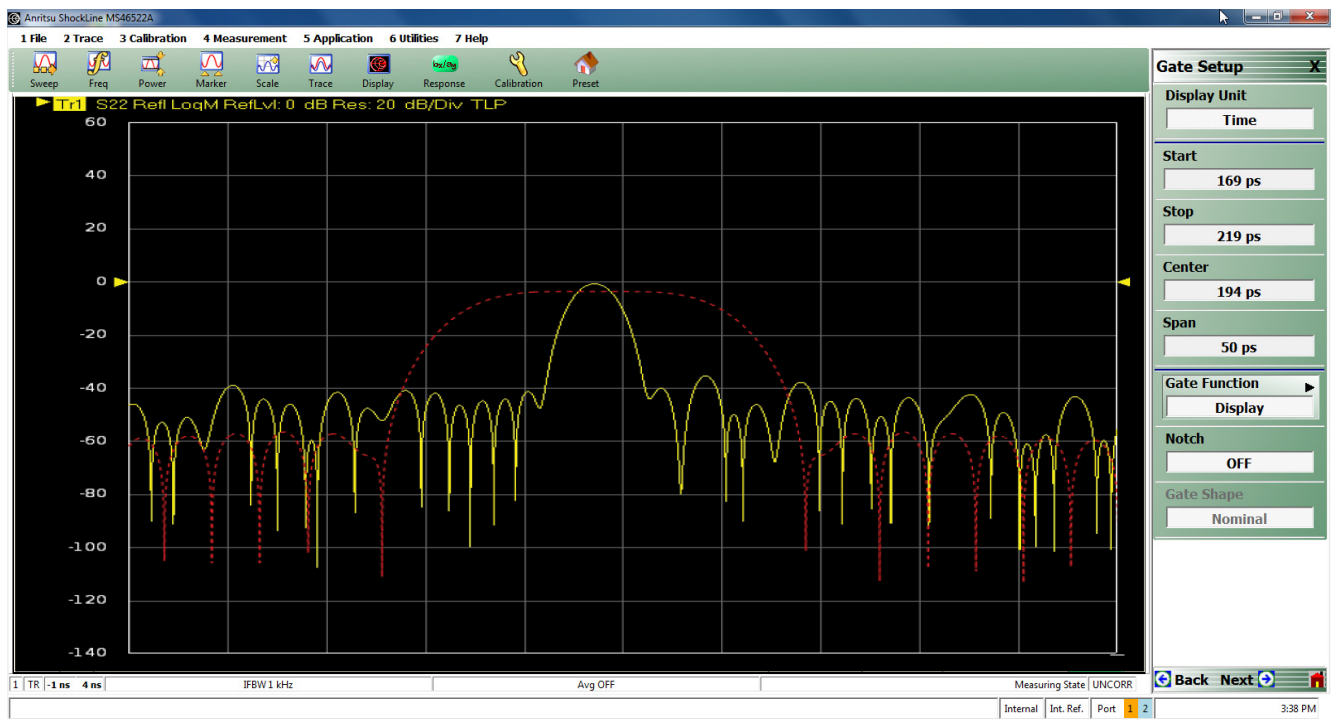

Figure 12-19. Gate in Display Mode Example

Next the gate is turned to on. In [Figure 12-20](#), the suppression of the time domain information outside of the gate area is seen.

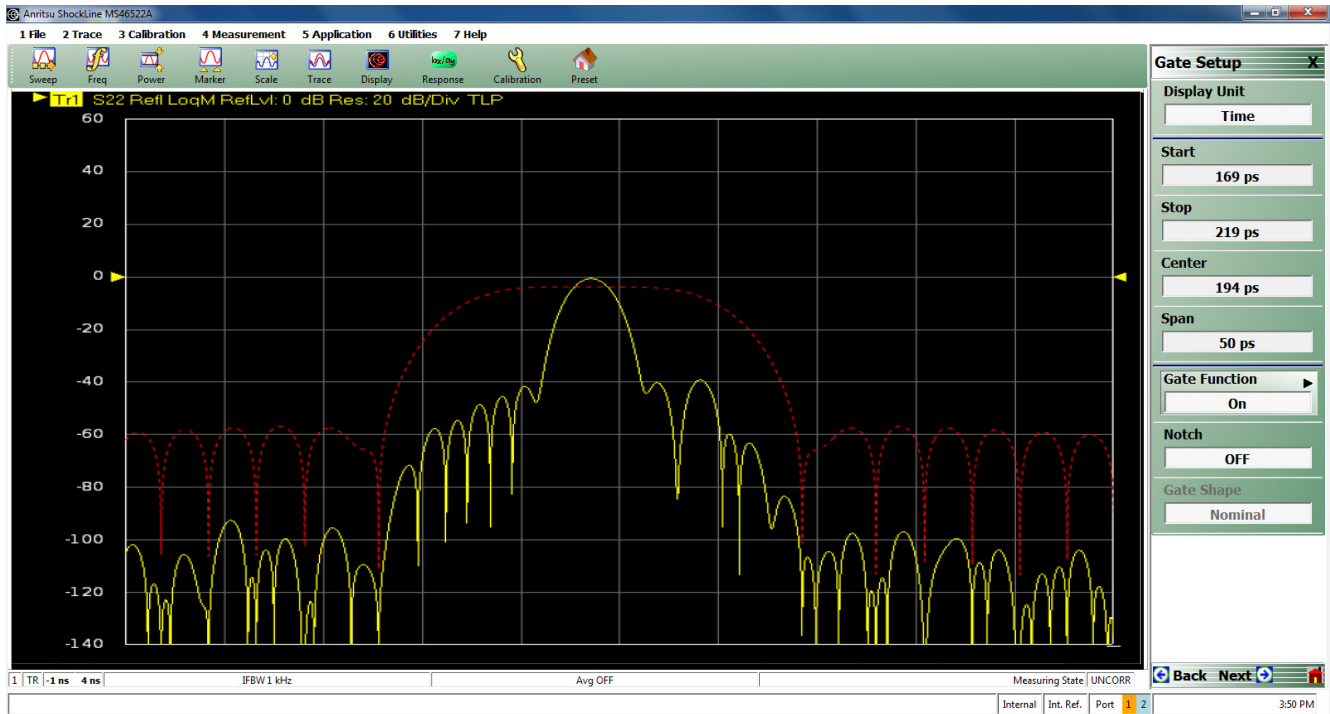

Figure 12-20. Gate Turned On Example

Finally, frequency with time gating is activated and the result is shown in [Figure 12-21](#). The result from frequency without time gating is shown in memory as a darker trace. The time gating has removed much of the ripple due to the mismatched transmission line and residual source match of the instrument.

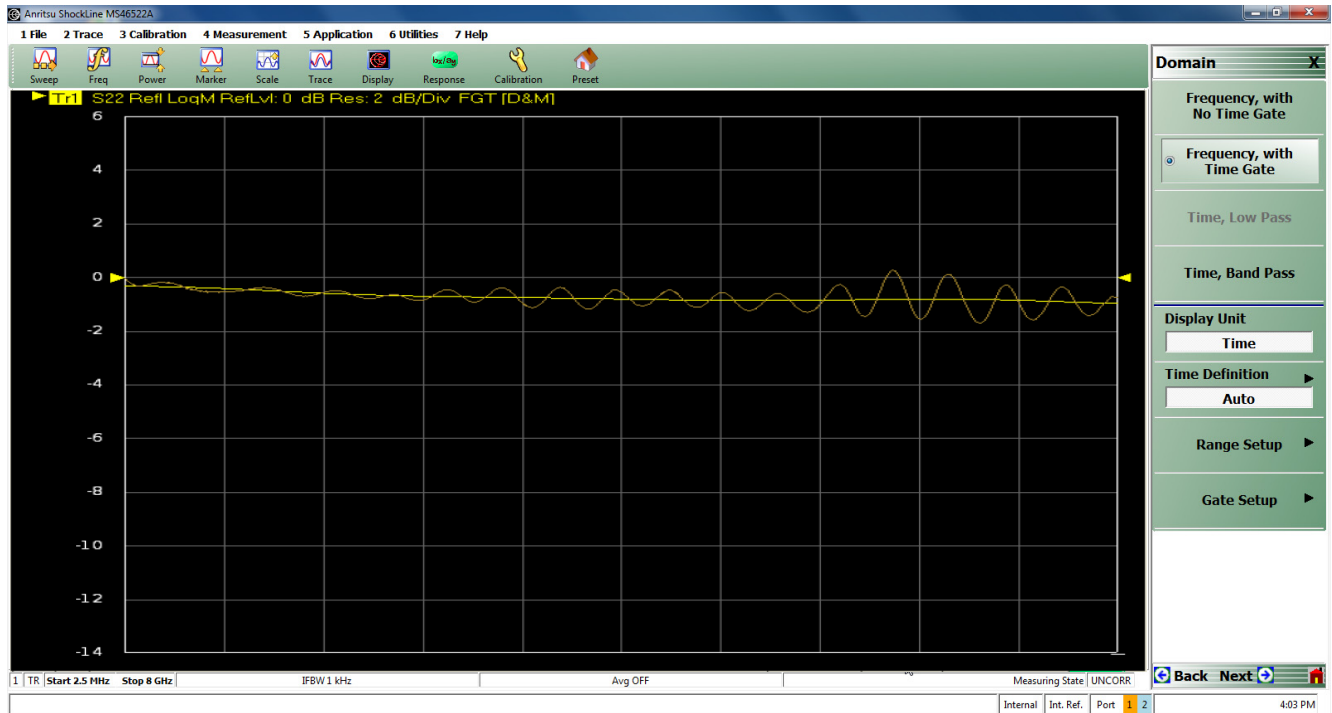

Figure 12-21. Frequency with Time Gating Example

Other Frequency-with-time-gate Calculation Items

Questions are sometimes asked about the details of the gating process and the subject of uncertainty in the final result. The latter topic is addressed in the next section. In terms of the process itself, the basic concept is simple enough: a particular functional form (to exclude or include certain portions) is applied to the time domain data before it is returned to the frequency domain. As the time domain data is theoretically of infinite extent, the limited data roster forces some truncation to happen by default so even with an infinitely wide gate, the process is not conservative.

To get around this problem, a calibration signal (a single, synthetic tone) is applied to the current window/gate setup to generate a set of correction factors. Normally this does not introduce any significant errors. If the gate is very narrow (in the sense of approaching $1/BW$), there is an additional issue in that the equivalent frequency domain convolution starts trying to interact more with frequencies outside of the sweep range. In the extreme case, this results in distorted final result, particularly at the extreme frequencies. To improve these results, the gate processing is done on a synthetically larger frequency range (using modeled extrapolation) to minimize out-of-range convolution effects. It is still advisable that the gate not be any narrower than a few resolution intervals.

A second type of question that often arises is on how to use and interpret FGT results on transmission parameters. Suppose one had a device in a fixture, one might think that one could de-embed transmission by simply placing a gate around the appropriate place. Unfortunately, it is not quite that simple. Consider the time domain representation of an impulse traveling through our fixture + DUT assembly.

In the time domain sense, an impulse is incident from the left and, at the first interface, some is reflected and some is transmitted. The transmitted impulse then sees the output plane of the DUT and again, some is reflected and some is transmitted. The transmitted impulse (labeled 'A' in Figure 12-22) goes to the receiver and this is the first response observed in the time domain transmission measurement.

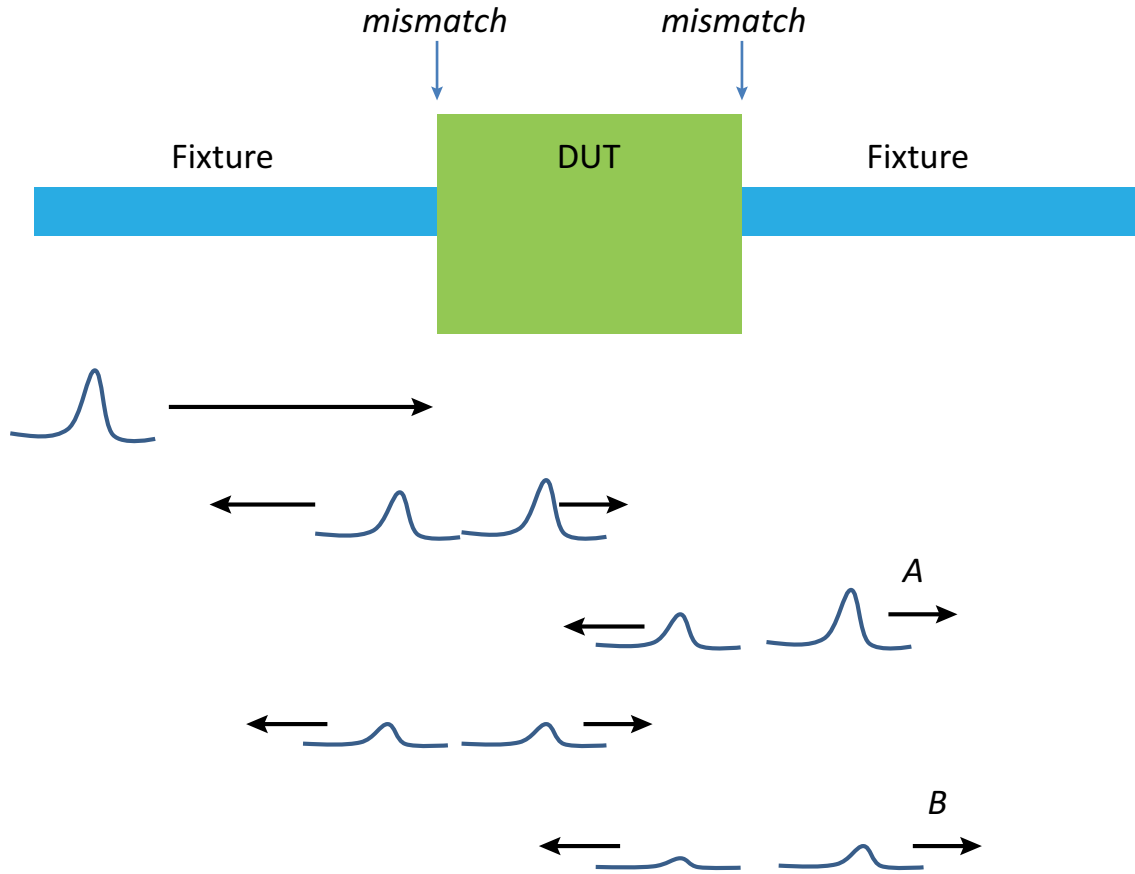

Figure 12-22. Illustration of Gating Effect on Pulse Re-reflections

If one follows the remaining pulse energy, there is an internally reflected impulse in the DUT that again emerges towards the receiver (labeled *B*). There may be additional re-reflections that contribute depending on the loss and reflection levels. Now if one places a gate around 'A', one will remove the contribution of re-reflections and this may reduce the ripple in the FGT response. This is not complete de-embedding, however, since 'A' includes loss effects of the fixture as well as any incident mismatch. Those effects were not removed by this gating process. For that fuller level of correction, more traditional de-embedding steps usually need to be followed.

Saving Gated Results

As usual, .txt and .csv formats (along with the graphical formats) can be used to save post-processed results. Many users also wish to save gated results in the .sNp file formats, but this is not enabled by default to avoid confusion on what the S-parameters represent. This can be turned on using a control at the bottom of the sNp Setup dialog box as shown in [Figure 12-23](#).

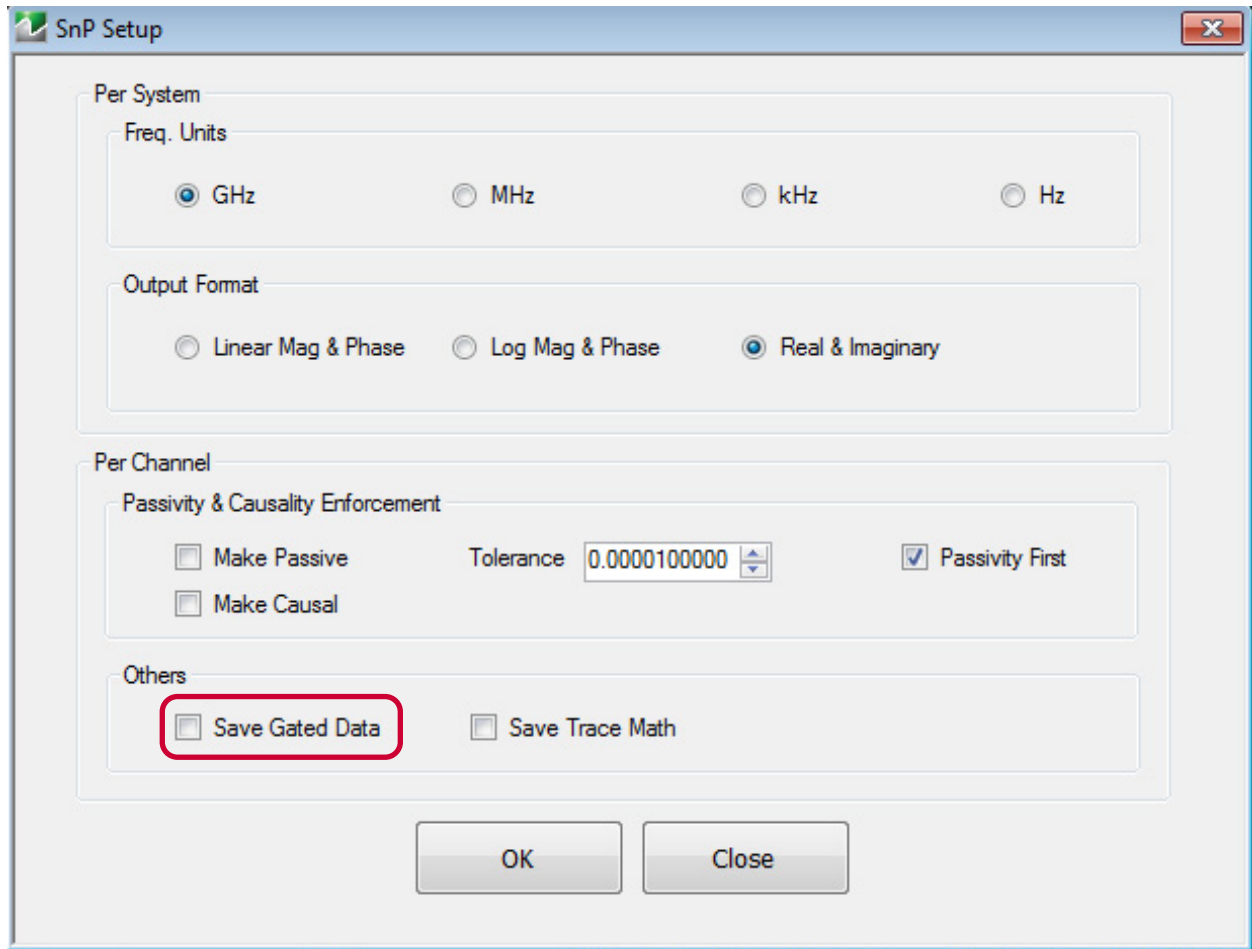

Figure 12-23. SnP FILES SETUP Dialog

As might be expected, there is some potential for confusion on which gate is applied to which parameter. The following rules are employed:

- If gating is applied on no traces on the current channel, only ungated .sNp data will be saved.
- If gating is applied on at least one trace and the save gated button described above is ON, gated data will be saved for all parameters (that are part of the current .sNp save request). In this case:
 - If all parameters of the .sNp are setup as gated in the current channel, those parameter-specific gate parameters will be used. The data from the last processed run will be used for the save.
 - If not all parameters are setup as gated, the gate parameters of the first gated trace of the same parameter type (transmission/reflection) will be used. If such a trace does not exist, the gate parameters of the first gated trace will be used. If a trace does not exist for the required parameter, its measurement will be taken from the buffer (if a calibrated parameter) or a measurement re-triggered (if not a calibrated parameter but part of the sNp save definition).
- If gating is applied to the .sNp file, a comment line (! GATING applied) will be added to the header of the file.

Chapter 13 — Measurement – Sweep Types

13-1 Chapter Overview

This chapter covers the sweep type available with the ShockLine MS46122A/B and MS46322A/B Series VNA to increase measurement functionality.

13-2 Introduction

A single sweep type is available within the MS46122A/B and MS46322A/B Series VNAs.

- Traditional frequency sweep (defined by a start frequency, a stop frequency and a number of points)

The SWEEP SETUP menu is shown in [Figure 13-1](#)

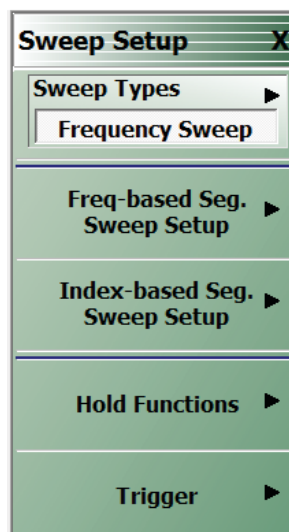

Figure 13-1. SWEEP SETUP Menu

13-3 Setting Up Traditional Frequency Sweeps (Linear and Log)

A traditional frequency sweep is based on a start frequency, a stop frequency, and a number of points (or, alternatively, substitute center/span for start/stop). The number of points is not confined to certain preset values. The minimum number is two (otherwise use CW mode) and the maximum number is usually 16,001.

Power entry while in frequency sweep mode is accomplished through the POWER [COUPLED] menu shown in [Figure 13-2](#).

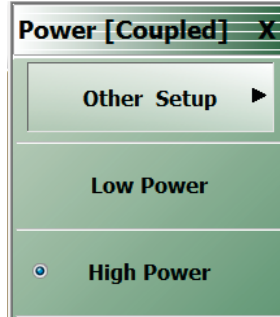

Figure 13-2. POWER [COUPLED] Menu

13-4 Maximum and Minimum Power Settings

For all configurations, the maximum power setting for:

MS46122A, MS46322A

- -3 dBm

MS46122B and MS46322B:

- +5 dBm (1MHz to 8 GHz)
- -3 dBm (>8 GHz to 43.5 GHz)

A summary of the power settings is in [Table 13-1](#) below.

Table 13-1. Summary of Maximum and Minimum Power Levels

VNA	Power Level	Power Setting	Output Power (Typical)
MS46122A/B-010 MS46122A/B-020 MS46122A/B-040	Maximum Power	High	-3 dBm
MS46122A/B-043 MS46322A/B-010 MS46322A/B-020 MS46322A/B-040 MS46322A/B-043	Minimum Power	Low	-20 dBm

Other Setup

This selection opens the MIN. PORT POWER dialog. (See description of dialog below) When Sweep Type is Segmented (Frequency or Indexed), this capability is not available and the button is deactivated and grayed out.

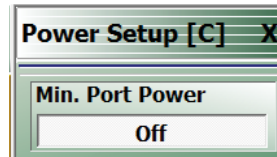

Figure 13-3. POWER SETUP Menu

Min. Port Power Dialog

This dialog has one button for on/off control of minimum power on the ports. When set On, the VNA will use the lowest output power it can achieve. (This is not the same as the Low Power setting, which simply applies the normal Low Power setting in sweeps.

13-5 Frequency-Based Segmented Sweep

In many applications, having a simple list of frequencies where the step size between points is uniform is not adequate. The DUT specifications may have specifications in certain bands and certain specific frequencies that must be tested, there may be certain communications bands that must be tested, or there may be certain spot frequencies that are of interest for troubleshooting or analysis.

For these cases and others, segmented sweep allows one to put together a very arbitrary list of frequencies to sweep as well as having some control of instrument behavior that is distinct at these different points and/or segments. The entire sweep is broken into segments (a segment may contain one or many points) and in each segment, one can independently control:

- IF bandwidth
- Averaging
- Port 1 Power and Port 2 Power

There is a distinction made between frequency-based and index-based segmented sweep that should be explained:

- **Frequency-Based**

Frequency is always monotonically increasing (within a segment and between segments). Plotting may be based on the frequency or the index of the particular point (more on this later).

- **Index-Based**

The segments do not have to be in any order with regards to frequency. Plotting is always based on the point index.

Frequency-based is most commonly used and will be discussed in this section. Index-based sweeps, which is used when reverse sweeps and particular frequency order is important, is covered in the next section.

The main menu and an example entry table are shown in Figure 13-4 and Figure 13-5. The main purpose of this menu is to aid entering data into the table and to help save and recall that data. Note that segmented sweep tables can be saved/recalled separately from this menu or they can be saved/recalled as part of the global setup using the entries under the FILE menu.

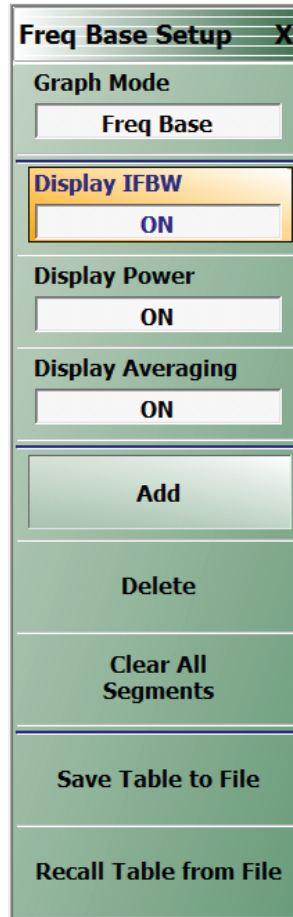

Figure 13-4. FREQ BASE SETUP (FREQUENCY-BASED SETUP) Menu

of Pts : 2 ^ v Enter

	Seg. On	Freq Def. for F1 & F2	F1	F2	# of Pts	Step/Stop Freq	IFBW	Src Power [Coupled]	Averaging
▶ 1	<input checked="" type="checkbox"/>	Start & Step Size	9.999992 MHz	13.5 GHz	2	13.50999999...	100 kHz	Low	2
2	<input checked="" type="checkbox"/>	Start & Stop	21.09999829...	30 GHz	2	8.900001701 ...	100 kHz	Low	3
3	<input checked="" type="checkbox"/>	Start & Stop	30.00000000...	30.00013 GHz	50	2.653040816...	100 kHz	Low	3

Figure 13-5. Tableau Entry Table for Frequency-based Segmented Sweep

The table will start with one segment and the start, stop and number of points must be defined. The pull-down item in Column 3 allows an alternatively specified start and step or a CW frequency. The step or stop frequency (which depends on the pull-down selection) will appear as a read-only field in Column 7. The IFBW, power and averaging columns can be enabled on the setup menu and entered separately by segment. The current source attenuator setting will appear in the column header and may not be changed by segment (will read 0 dB if the attenuators are not installed). If the display of these fields is not enabled, the values for those variables set in regular frequency sweep mode will prevail for all segments.

The Add, Delete, and Clear All functions are obvious. The delete function applies to the current row as indicated by the caret in column 1.

As with the multiple source tables, there are two ways to enter numbers

- Click on the cell and the text entry box above the table becomes active.
- Click twice on the cell and type directly into the cell. Frequency units must be entered and must have a space between the number and the units.

If an invalid number is entered in any field, the system will change the value to the nearest valid entry.

The one remaining item on the setup menu for frequency-based segmented sweep is graph mode, which controls how the x-axis is setup for all plotting activities but does not affect the sweep itself. In Frequency-based graph mode, the x-axis will be in frequency and all segments will be plotted where those frequencies lie. While correct, this can lead to an odd-looking display if the segments are disjointed as shown in Figure 13-6.

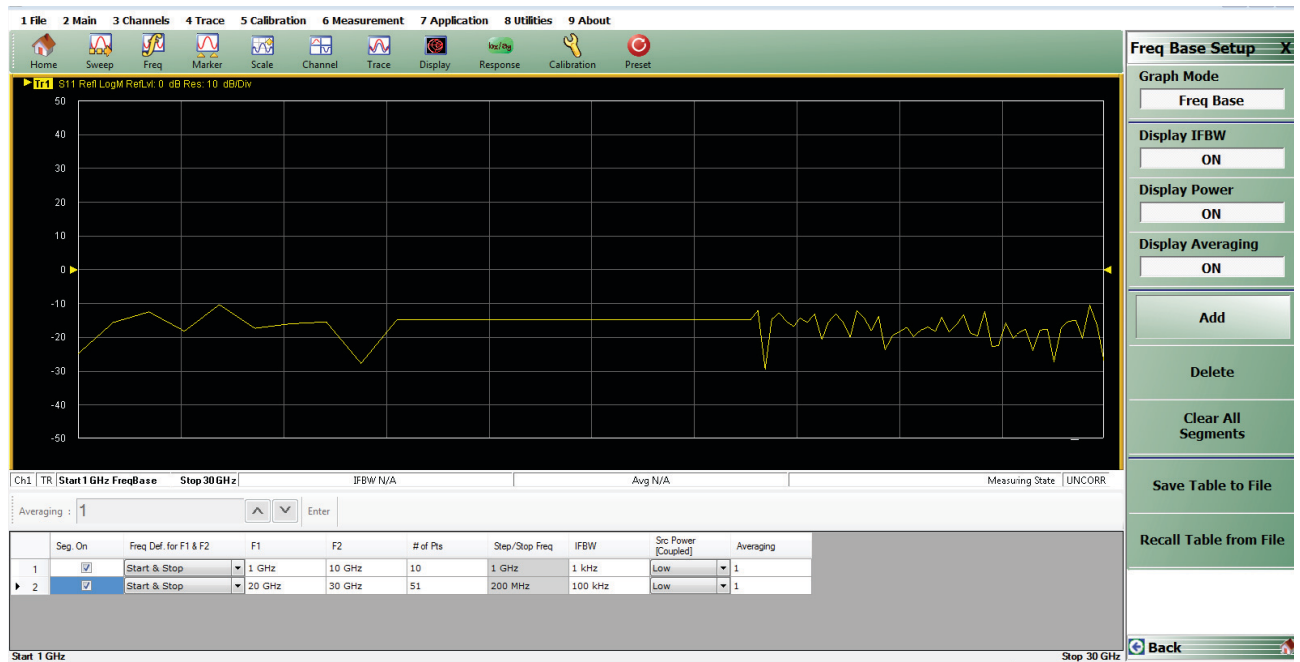

Figure 13-6. Frequency-Based Graph Mode

Since Segment 1 covers 1-10 GHz and Segment 2 covers 20-30 GHz, there is a gap in frequency where no measurements are made. For the purposes of plotting in this graph mode, the two areas are connected by a single line segment. Note that the point spacing in the plot precisely matches the frequency spacing.

When all of the data points plotted without regard to proportional frequency separation are required. For these occasions, the Index-based graph mode is available and an example is in Figure 13-7 for the same setup as Figure 13-6. Here, the x-axis is point index so all plotted points are equally spaced in the x-direction and the frequency based segmented sweep is disjointed.



Figure 13-7. Index-Base Graph Mode

It is important to keep separate the concepts of frequency- vs. index-based for the graph mode (which only controls how things are plotted) and frequency- vs. index-based segmented sweep type (which determines how the points are swept by the instrument hardware).

13-6 Index-Based Segmented Sweep

In index-based segmented sweep the frequency segments may be in any order. This may be useful for particular test patterns where reverse sweeps are needed or particular frequencies must be measured before others due to DUT hysteresis. The setup menu and an example table are in [Figure 13-8](#) and [Figure 13-9](#).

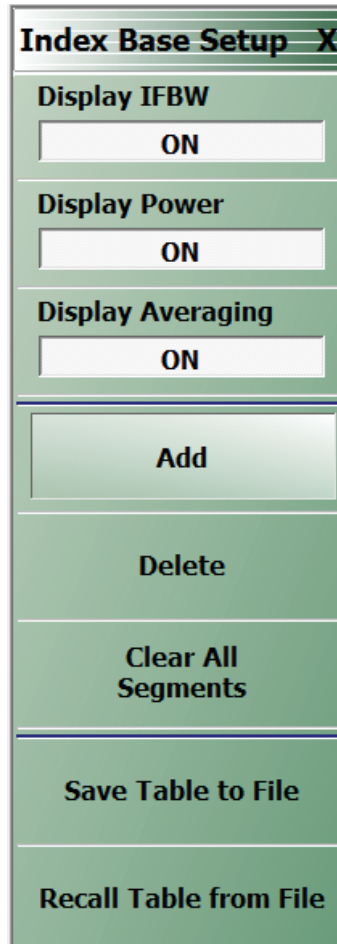

Figure 13-8. Main Menu for Index-based Segmented Sweep - INDEX BASE SETUP Menu

All plotting in this sweep type is based on the point index, which is listed in the last column of the table below.

Ch1	TR	Start 0	IndexBase	Stop 67	IFBW N/A		Avg N/A			
F2 :		10.000000000		GHz	MHz	kHz	Hz			
	Seg. On	Freq Def. for F1 & F2	F1	F2	# of Pts	Step/Stop Freq	IFBW	Src Power [Coupled]	Averaging	Index Range
▶ 1	<input checked="" type="checkbox"/>	Start & Stop	10 MHz	10 GHz	15	713.5714285...	100 kHz	High	1	0-14
2	<input checked="" type="checkbox"/>	Start & Stop	25 GHz	26 GHz	51	20 MHz	100 kHz	High	1	15-65
3	<input checked="" type="checkbox"/>	Start & Stop	6 GHz	27 GHz	2	21 GHz	100 kHz	High	1	66-67

Figure 13-9. Tableau Entry Table for Index-based Segmented Sweep

Aside from the increased flexibility in ordering, there are few other differences relative to frequency-based segmented sweep. One exception is that there is now no choice of graph mode; it will always be index-based. In this case, it is to avoid confusing and unreadable displays where one could have many reverse tracing operations.

Chapter 14 — E/O and O/E Converter and Optical Measurements

14-1 Chapter Overview

As fiber and free-space optical communication bandwidths increase, the need for very high speed optical modulators and detectors has also increased. The frequency response characterization of these *electrical-to-optical* (E/O, modulators sometimes integrated with lasers) and *optical-to-electrical* (O/E, detectors and receivers) converters can be important in terms of such parameters as bandwidth, flatness and phase linearity. In addition, the microwave frequency response characteristics of certain *purely optical* (O/O) components may be of interest as their optical bandwidth may be narrow (couplers, amplifiers, filters, etc.) or may have unusual dispersion characteristics. The ShockLine Series VNA have a number of measurement utilities to facilitate this kind of analysis and, coupled with the MN4765X O/E calibration module or some other calibration device, some level of measurement traceability is possible. This chapter will discuss some of the measurements of interest, setup considerations, possible measurement performance, and examples of execution procedures.

14-2 Introduction and Background

Conceptually, the job of the optical modulator is to place a microwave signal as modulation onto an optical carrier. Similarly, the job of the photodetector or receiver is to recover that modulation and regenerate the microwave signal. For a VNA-based measurement, both directions of conversion are required so that the processing can occur in the microwave or modulation signal domain. The result is a setup like that shown in Figure 14-1. The optical carrier is generated (usually) by a coherent laser source (which may be integrated with the modulator), modulation is applied, and then the modulation is recovered. Optical fiber is shown as the media in Figure 14-1 but it could be some other optical guiding medium or free-space in some cases. The VNA acts as a microwave stimulus (Port 1 in the figure) and receiver (Port 2 in the figure). Although a fiber is shown as the only element between the detector and modulator in Figure 14-1, some optical DUT may be there for O/O measurements.

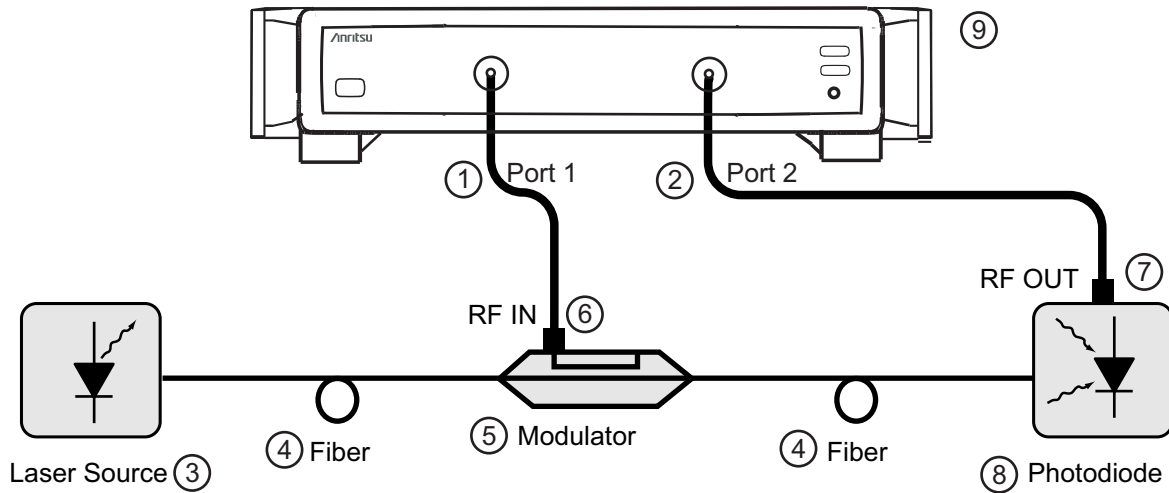

Index	Description	Index	Description
1	VNA Port 1	6	Modulator RF IN
2	VNA Port 2	7	Photodiode RF OUT
3	Laser Source	8	Photodiode
4	Fiber	9	MS46122A/B or MS46322A/B VNA
5	Modulator		

Figure 14-1. A general 2-port E/O or O/E measurement setup

In some cases, the laser and modulator may be one assembly. The photodiode may be integrated with amplifiers or other components into a photoreceiver.

Since the measurements results will be classed as normal S-parameters, one may wonder how these relate to the actual optical behaviors of the components. In some sense, they all become relative because the conversion between domains introduces dependencies on optical laser power, optical path losses (usually small) and other absolute shifts. Thus the real measure of conversion is essentially a responsivity slope between the optical and electrical domains as illustrated in Figure 14-2.

The S-parameters that appear on the instrument display for an O/E or an E/O component then represent a relative responsivity measure (in both magnitude and phase). Often, the frequency response of this quantity is of interest as that determines bandwidth and magnitude vs. frequency plot gives this information. The phase linearity and group delay are both ways of looking at the deviation from a purely linear phase function that can be an important assessment of potential phase-related modulation distortion. Return loss of the component may also be of interest but that is a purely microwave measurement.

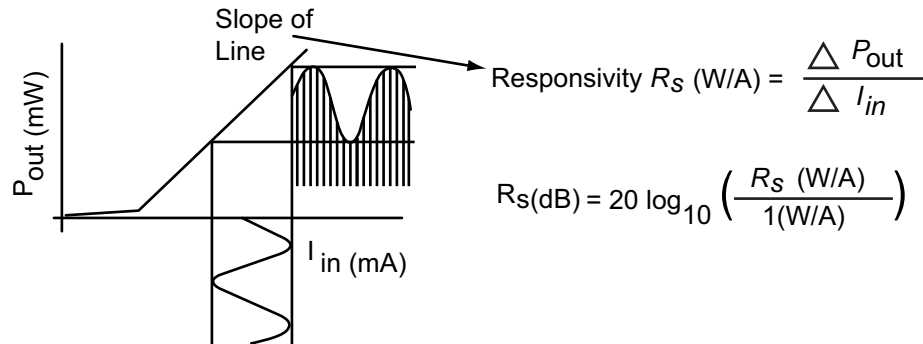

Figure 14-2. Concept of responsivity

The conversion parameters of the O/E and E/O devices measured with the VNA are essentially measures of responsivity.

A next question may be how the measurements are conducted. The starting point is a two-port VNA calibration as has been discussed in earlier chapters of this measurement guide. This calibration establishes reference planes at the microwave ports of the optical devices as shown in [Figure 14-3 on page 14-4](#) (often coaxial ports but could be waveguide, in a fixture, etc.).

The next step is the use of an O/E calibration device such as the MN4765X. That particular model is a wide bandwidth photodetector housed in a thermally controlled module with carefully designed bias circuitry. This module is characterized at a traceable facility using electro-optic sampling techniques (or references derived from that) so its frequency response (in magnitude and phase) is well-known with established uncertainties (e.g., [1] -[2]).

If such a calibration device is the detector in Figure 14-1, then its effects can be de-embedded (see the embedding/de-embedding sections of Chapter 9 in this guide for more general information) since those behaviors are known. This then moves the reference plane to the optical side of the photodiode/calibration detector as shown in Figure 14-3. Now a measurement of S21 will describe the loss and phase of the modulator alone (plus some effect of the fiber which will be discussed). This frequency response (magnitude and phase) gives the required performance information discussed earlier when combined with the microwave reflection measurement (S11 in the diagram) of the modulator RF port that comes for ‘free’ with the calibrated VNA measurement.

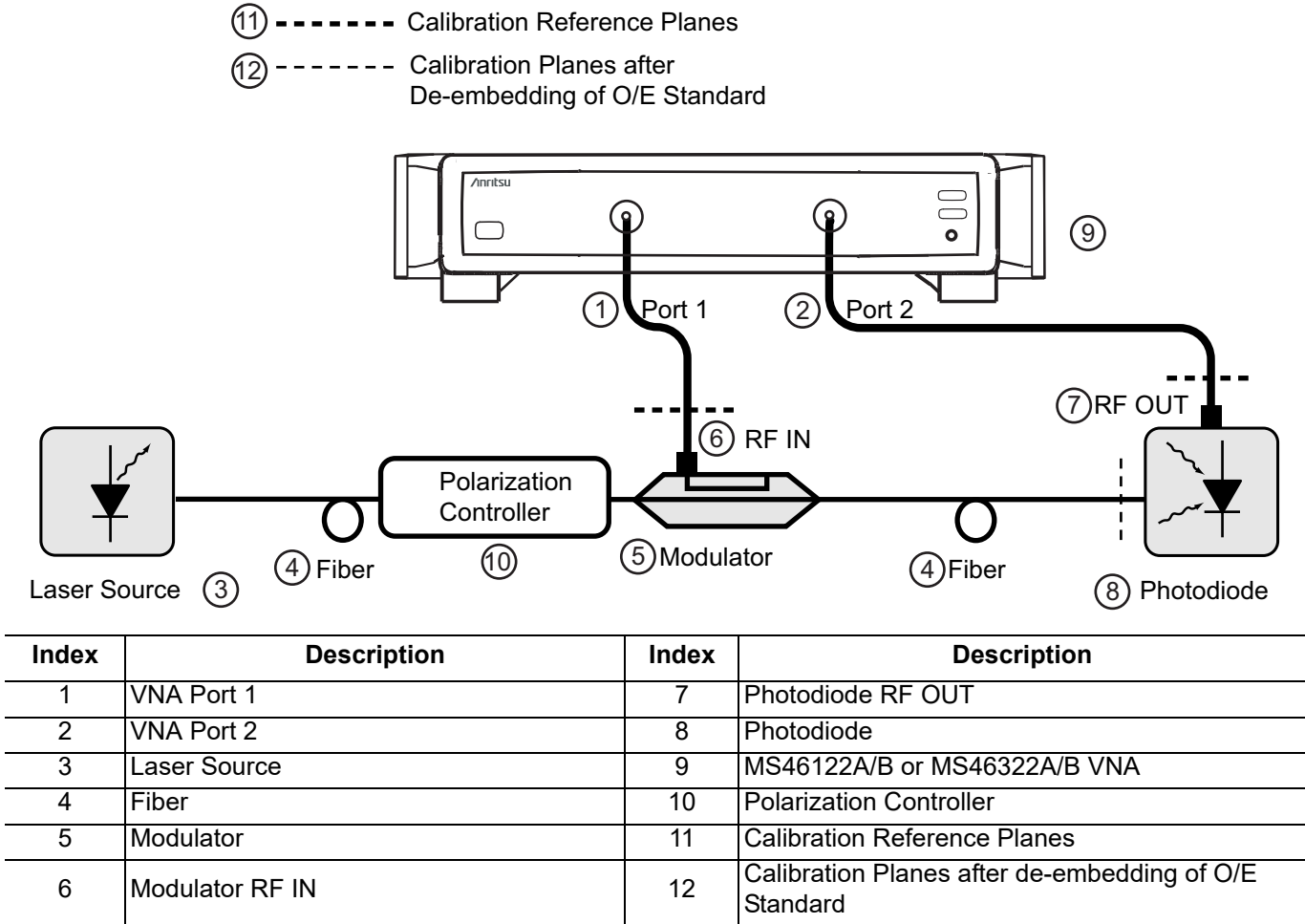

Figure 14-3. Reference plane placement

A calibration is done in coax, waveguide, or some other electrical media and the de-embedding function, via the O/E-E/O measurement utility, of the VNA are used together with optical data to move a reference plane into the optical domain.

The MS46122A/B and MS46322A/B have a maximum frequency of 43.5 GHz. The following example is primarily for explanatory purposes. An example plot of the conversion response of a 50 GHz photodetector is shown in Figure 14-4. From the magnitude response, the 3-dB bandwidth is indeed around 50 GHz but the roll-off is sufficiently slow that this device is commonly used beyond 65 GHz.

Device Response

The device response is shown in the figures below, but the linear portion has not been removed. The group delay plot (derivative of phase with respect to frequency) is often a more convenient way of looking at the phase behavior. Towards 50 GHz, there are some deviations from flat group delay (equivalent to deviations from linear phase) that are not surprising in view of the device's bandwidth. If being used as a characterization device, these deviations are not important since they can be well-characterized (to beyond 65 GHz in this case).

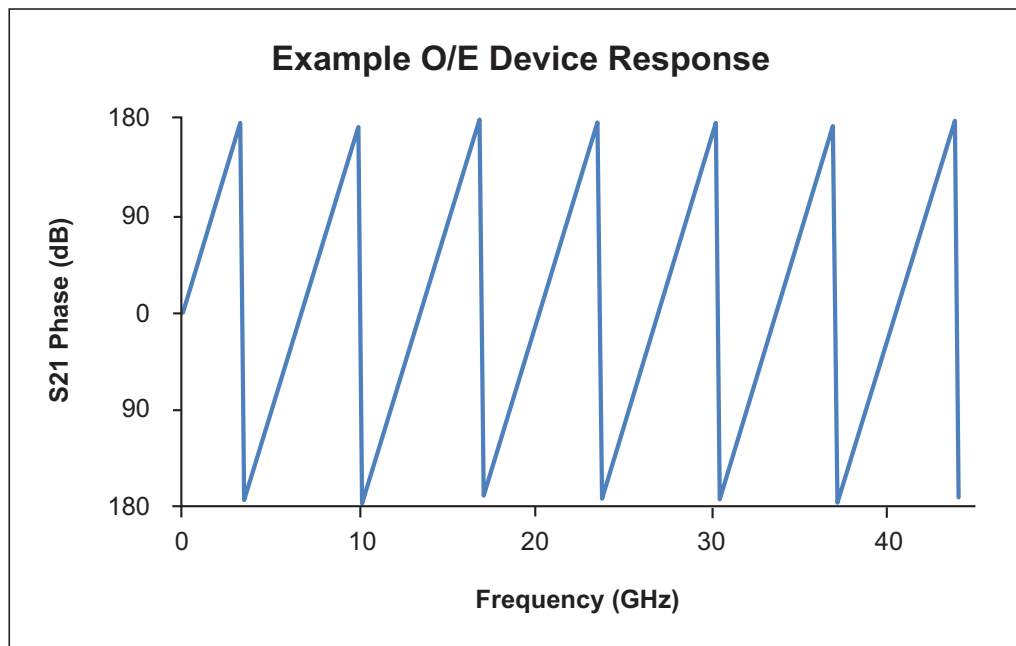
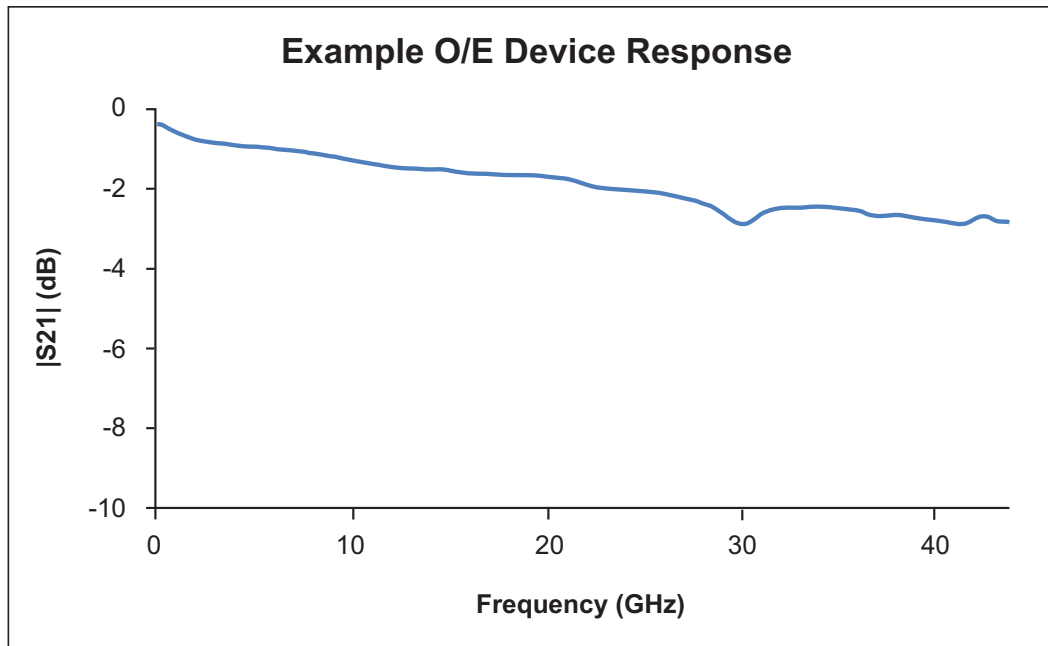

Figure 14-4. Characteristics of an example O/E device

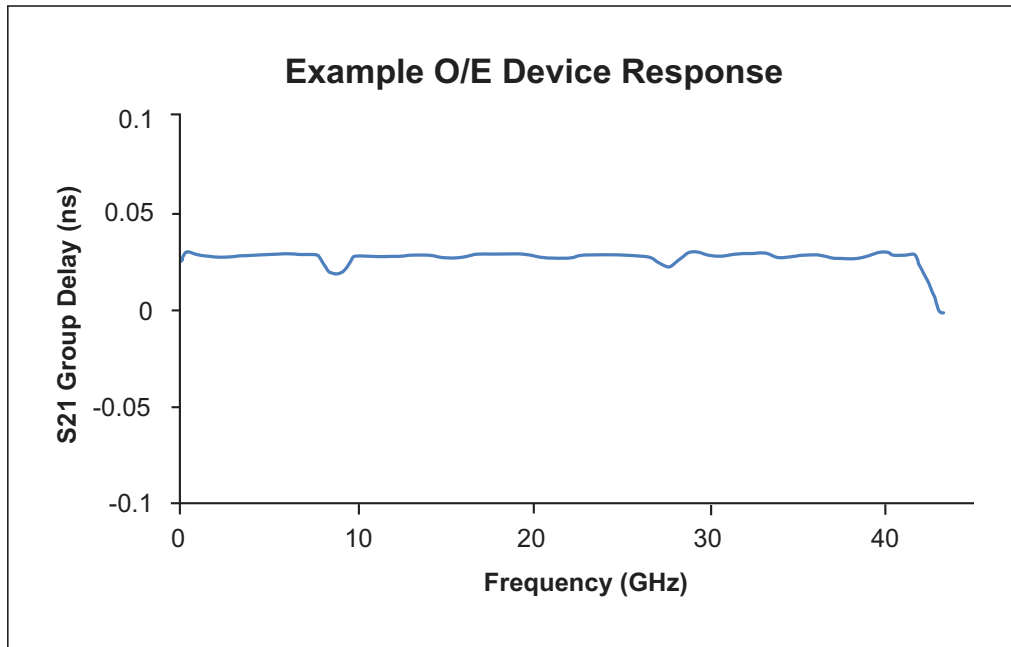

Figure 14-4. (Continued) Characteristics of an example O/E device

If one now wanted to measure a different O/E device (not a calibration module), one could then insert that detector into the setup of [Figure 14-3 on page 14-4](#) and instead now de-embed the modulator response that was just found. In this case, because it is a second level de-embed, there may be some elevation of uncertainties that will be discussed. One could also obtain an E/O calibration device and use that instead in a one-step process.

The de-embedding (or sequential de-embedding) steps form the basis of this O/E-E/O measurement utility. The key points are controlling traceability and uncertainties throughout the process when multiple devices are being used, to control match so minimal additional artifacts are introduced, and to not try to de-embed what cannot be de-embedded. This last point is important in that inner-plane (optical) match is not known and the transmission path is unilateral anyway, so there are no multiple reflections within the DUT assembly to remove.

Optical Measurements Menu

All of these measurement aids are available under the O/E-E/O-O/O button on the MEASUREMENTS menu (Navigation: MAIN | Measurement | MEASUREMENT | O/E-E/O-O/O button | OPTICAL MEAS. menu.) As might have been guessed from the previous discussion, these approaches naturally separate based on whether the target is an O/E device (e.g., detector or receiver), an E/O device (e.g., modulator), or an O/O device (e.g., coupler, amplifier, or filter, etc). The menu selections, as shown in [Figure 14-3](#) delineate that choice.

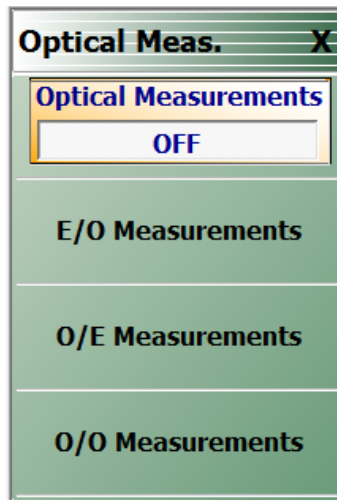

Figure 14-5. On the OPTICAL MEASUREMENTS menu are three selections based on which type of device is to be solved for.

A certain class of purely optical (O/O) measurements can also be made where both the detector and the modulator have been de-embedded. One essentially performs the steps for both the E/O and O/E measurements in series to place the reference planes in the optical domain. This is still a microwave/millimeter wave frequency response measurement so the O/O measurement is really a measure of the response to changing modulation bandwidths and, as such, is most suited to relatively narrowband optical devices such as amplifiers, filters, couplers, resonators, etc. For example, it would be unusual for a patch cord to show variation over a millimeter wave modulation bandwidth (unless it had some particularly unusual distortion properties). Also, mismatch in the optical domain is not correctable with this technique and, if the fiber runs are long, it is possible that ripple will occur on the scale of millimeter wave frequencies.

All of the measurements in this chapter work by using information about optical converters to modify an RF calibration coefficient set on the ShockLine VNA. This is exactly how conventional de-embedding works but the optical variants of this process take additional steps to handle the unilateral nature of the optical system (one cannot apply RF to the detector and usually expect RF to be produced by the modulator) and some differences in match terms. As with regular de-embedding, the optical modification to the calibration coefficients can be turned on and off. Turning the Optical Measurements to OFF will cause the original RF calibrations coefficients to be loaded. Returning Optical Measurements to ON will reload the modified coefficients. Both sets of coefficients are stored as part of the setup file.

14-3 Measurement Setups and Considerations

It is not the intent of this chapter to fully cover the optical setup details. However, some common issues and concerns will be discussed. More general information of fiber optic measurement setups can be found elsewhere (e.g., [3]-[4]).

Optical Linearity

The linearity of the characterized photodiode directly affects the accuracy of the measurement and the optical input power at which RF photocurrent will remain linear is important. One way to check that the measurement path is still linear is to normalize the S21 plot against itself and increase the optical power to see if there is a gross sensitivity. For example, set the optical laser power to 4 or 5 dBm with the setup like that of [Figure 14-1](#). Store the resulting S21 to memory (under the Display/View Trace menu) and then view DataMemMath (data divided by memory). Now increase the laser power in 1 dB steps until some compression is seen in the normalized plot on the scale of 2 dB/div. At that point, decrease the optical power level until it is out of compression. Make sure that the maximum DC current for the photodiode is not exceeded.

Laser Power and Photodetector Bias Sequencing

Always make sure the photodiode is biased properly before turning the laser on. Improper bias or no bias can degrade photodiode performance and can also result in damage. Instructions on handling and biasing of the photodiode are shipped with the characterized photodiode accessory. Always observe ESD precautions as these devices are very sensitive to static discharge.

Optical Fiber Lengths

The measurement setup will typically require optical fibers to interconnect optical components with different connectors. For example, a modulator with an FC/PC connector at the output will require an optical patch cord to adapt to the FC/APC connector on the input of the characterized photodiode accessory. Optical fibers have negligible frequency dependent loss over microwave modulation bandwidths. Thus, adding short lengths of optical patch cords to the setup does not affect the accuracy of transfer function measurements. To avoid certain polarization-related issues, it is recommended to keep the patch cord length under 10 m. The use of patch cords appropriate for the wavelength being used is recommended, as multi-mode propagation is possible in some cases and may result in some measurement instability.

Modulator Bias Control

Lithium niobate modulators are generally biased using a modulator bias controller (MBC) to control the operating point of the modulator. When biased in quadrature, the input RF signal linearly modulates the optical carrier. Note that when an MBC is applied, it must be designed for small signal operation. The default power from the Port 1 test port is -10 dBm. This level results in a modulation depth of <10% for many commercially available modulators. If a different model VNA or a different option configuration is being used, it may be required to drop the VNA power level from the default setting to ensure that the modulator is operating linearly. Different technology modulators may have different linearity limits so it may be required to consult the manufacturer of that device.

A DC power supply can be used in place of an MBC. However, the stability of the measurement may be degraded due to drift in the modulator's bias point.

Connector Care

It is important to establish proper cleaning procedures when connecting fiber optic devices together. Fiber optic cores are made of glass and can easily be scratched or chipped if care is not taken. The connectors found on the MN4765X are of the FC/APC type. APC (Angled Physical Contact) is chosen to help minimize back-reflection. The 8° angle at the end-face of the APC connector has an optical return loss of better than 50 dB. DFB lasers require large amounts of reflection isolation to function properly. The optical return loss from a common PC connector can 30 dB or worse, depending upon the polish and cleanliness of the connector.

The following are some tips to help ensure quality connections:

- Always clean connectors after every connection.
- Use a fiber optic scope often to ensure there are no defects on the connector end face that can cause damage to other connectors.
- Use insertable patch cords for expensive devices that require many connections.
- Always use a cloth that is free of fiberglass to clean the connectors. If necessary, use alcohol to remove stubborn dirt and oil. Thoroughly remove any alcohol residue before reconnecting.
- Avoid using any oils for connecting two cables together. Oils are messy and very difficult to clean up.
- Optical connectors do not need torque. Some connections are better when the two fibers are barely touching. Tightening the connector too much will result in higher insertion loss, more reflection, and in some cases damage to the connector.
- Always observe proper mating to APC connectors. Connecting APC to PC connectors will damage the connectors.

14-4 Example 2-Port Procedures

With the physical setup described, the next task is really how to interface with the measurement utilities. Consider first the case of a 2-port E/O measurement where one has a characterized O/E device (such as the MN4765X). The dialog for this measurement is shown in [Figure 14-7 on page 14-11](#) (the system automatically detects if it is a 4-port configuration in which case one of the later dialogs would be displayed instead). One choice that has to be made is the port configuration. The default is to have the E/O device connected to port 1 of the VNA, but this can be changed.

Navigation to 2-Port E/O Measurement Dialog Box

MAIN | Measurement | MEASUREMENT | O/E-E/O-O/O button | OPTICAL MEASUREMENT |
E/O Measurements | 2-PORT E/O MEASUREMENT dialog

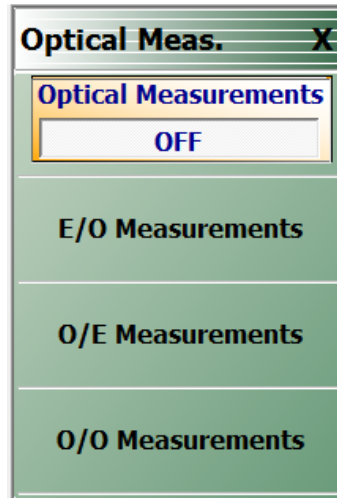

Figure 14-6. OPTICAL MEASUREMENT Menu

The other major requirement is a 2-port VNA calibration. This dialog assumes that the calibration has already been done with the desired method, frequency range, etc. and saved (using **Save Setup** under the **FILE** menu) as a .chx file. Most of the setup parameters are obvious:

- **Frequency Range and Number of Points** (dictated by the bandwidth of the DUT among other test requirements)
- **Power Level** (this depends on the linear drive range of the modulator as discussed above and the maximum available power of the VNA, which varies with options. Generally, the higher the better within those limits for best signal-to-noise ratio)
- **IF Bandwidth and Averaging** (trade-off between measurement time and trace noise. Generally 10-100 Hz IFBW is recommended for very wideband devices since the conversion losses tend to be high and the signal-to-noise ratio is stressed). Averaging can be added for additional trace noise reduction but there is a point of diminishing returns beyond about 10 sweep-by-sweep averages or if IFBW/(pt-by-pt averages) falls below 1 Hz.
- **Calibration Method** The only requirement is that the calibration contain a transmission path that match the E/O → O/E path (anything beyond that is acceptable). Some of the choices are:

E/O Port = 1

Forward transmission tracking (1 → 2)

1 path – 2 port forward (1 → 2)

Full 2 port calibration

E/O port= 2

Reverse transmission tracking (2 → 1)

1 path – 2 port reverse (2 → 1)

Full 2 port calibration

Any calibration algorithm can be used as appropriate.

Assuming this setup file is now available, it can be loaded in the dialog of [Figure 14-7](#) as can the O/E characterization file (in a .s2p file format). Note the **Swap ports** checkbox availability near the characterization portion of the dialog box. It is always assumed that the dominant path in the characterization file is the S21 parameter. If the file was constructed differently (e.g., S12 was the measurement path for the calibration device), then selecting the checkbox will force the instrument to reorder the ports in the file before processing.

When **Done** is selected on this dialog, the de-embedding is applied and the resultant calibration left on the system includes the shifted reference plane as suggested by [Figure 14-3 on page 14-4](#). This state can be saved as a new setup file (again using the **Save Setup** command under the **File** menu) if desired. Note that to go back to the non-de-embedded state, one can recall the old setup file that was just loaded in the dialog box. At this point, one can make measurements of any number of E/O devices and save the results using any of the usual techniques.

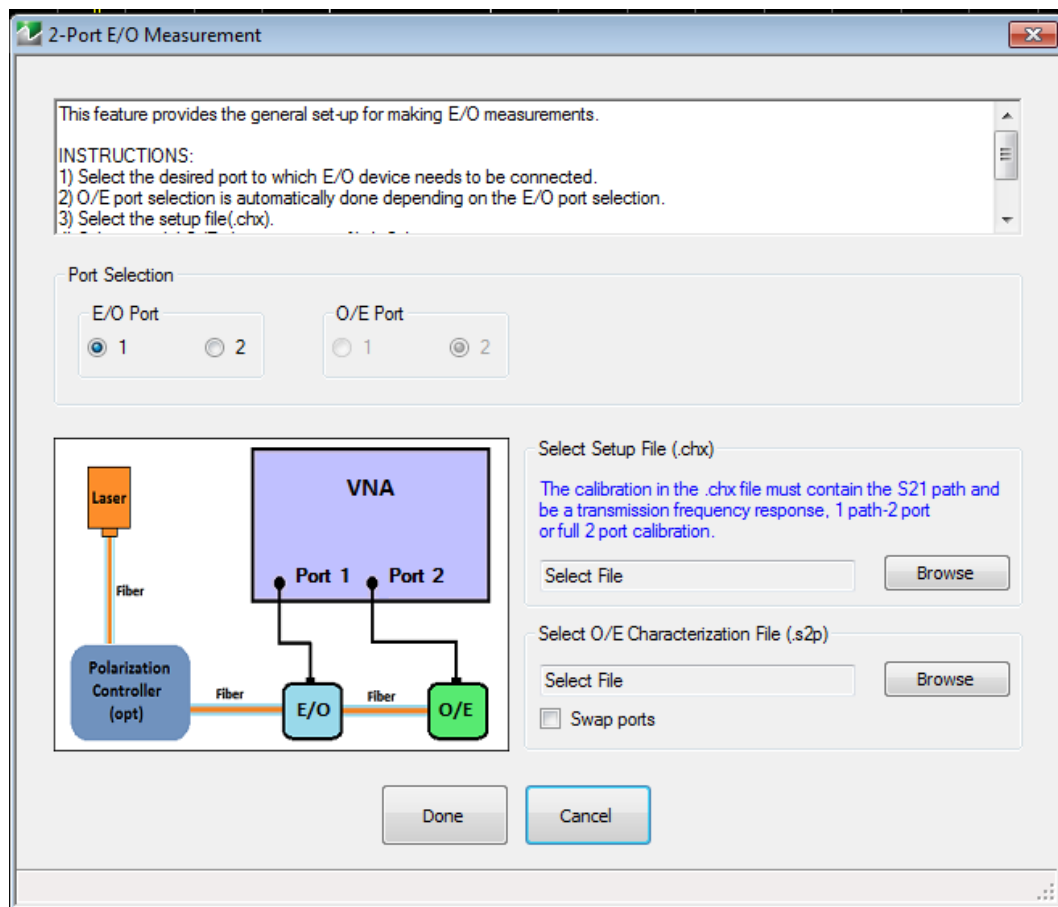

Figure 14-7. Dialog for 2-port E/O measurements

The O/E measurement setup is quite similar and that dialog is shown in [Figure 14-8](#). The difference, of course, is that an E/O characterization file must now exist. One can generate it using the previous procedure and saving the measurement result as a .s2p file or one may already have a characterization file for the E/O device. If this is not the case, a shortcut is provided to help generate an E/O characterization file with less work. This path is triggered with the **Go Measure E/O** button which will bring up the sub-dialog of [Figure 14-9](#).

Assuming one has an O/E calibration device (such as the MN4765X), this Go Measure feature allows one to load that photodetector characterization file and use the setup file found on the main E/O dialog to do a quick measurement of the modulator (or assembly). The sub-dialog also has a field to save this new E/O characterization file. When completed, one can go back to the previous dialog and select Done. The resultant setup will now have the Port 1 reference plane moved to after the modulator so one can now measure any number of new O/E devices. Again, the final setup (with shifted reference planes) can be saved as can any new measurement data of the O/E devices.

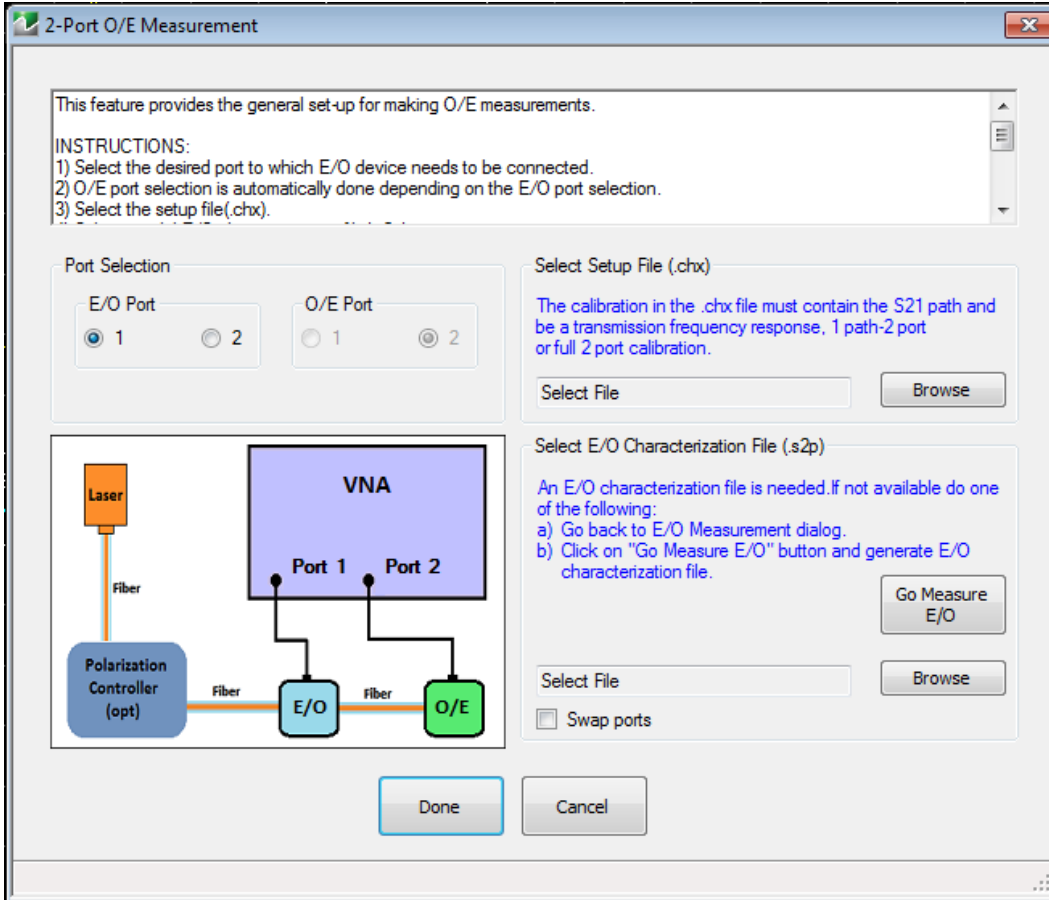

Figure 14-8. Dialog for 2-port O/E measurements.

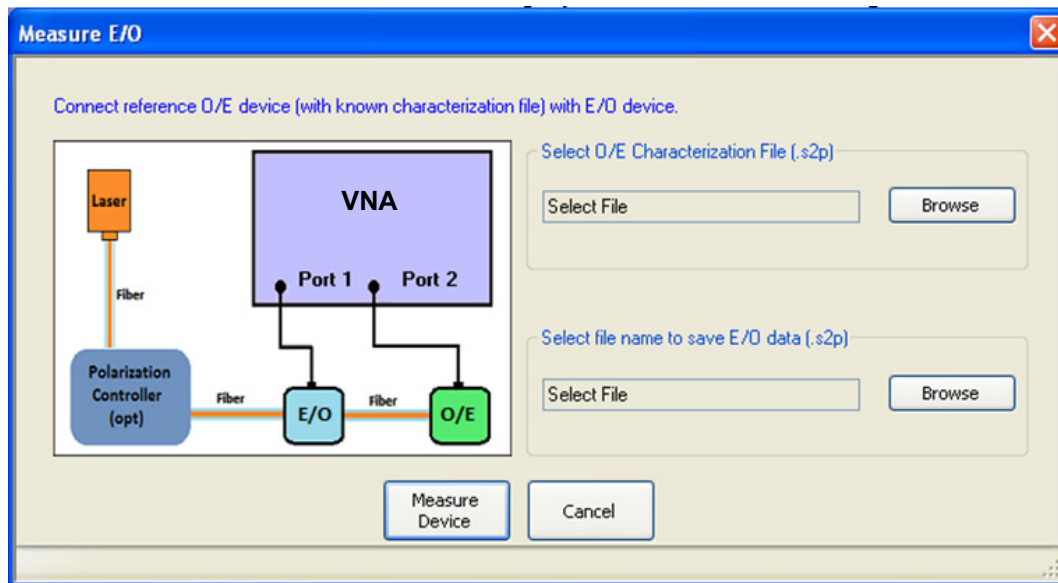

Figure 14-9. When measuring O/E devices, the characteristics of the E/O device must be known. If a file does not already exist, this dialog can help in doing the intermediate measurement with the help of a calibration O/E device such as the MN4765X.

The O/O measurement is somewhat like the E/O and O/E measurement setups in series: both the detector and the modulator must be de-embedded to leave the reference planes in the optical domain. As suggested by [Figure 14-10](#), if both .s2p files exist, their file names can be entered directly and the de-embedding will proceed. If one of them does not exist (usually the modulator file, but either is allowed), it can be measured on the fly much like with the Go Measure process in the O/E measurement previously. This Go Measure process (dialog shown in [Figure 14-11 on page 14-15](#)) allows one to enter the known device's file and to define the file name for the newly created file. Note that this Go Measure process assumes the modulator and detector are directly connected together in an optical sense and this defines the reference plane locations. In some sense, this step is like an optical normalization.

Note that the .s2p file name for the known device is assumed to be the same as that used on the main O/O dialog as this device normally doesn't change between Go Measure and O/O configuration steps. If a different device is to be used, the file name on the main O/O dialog can simply be changed after the Go Measure process is completed.

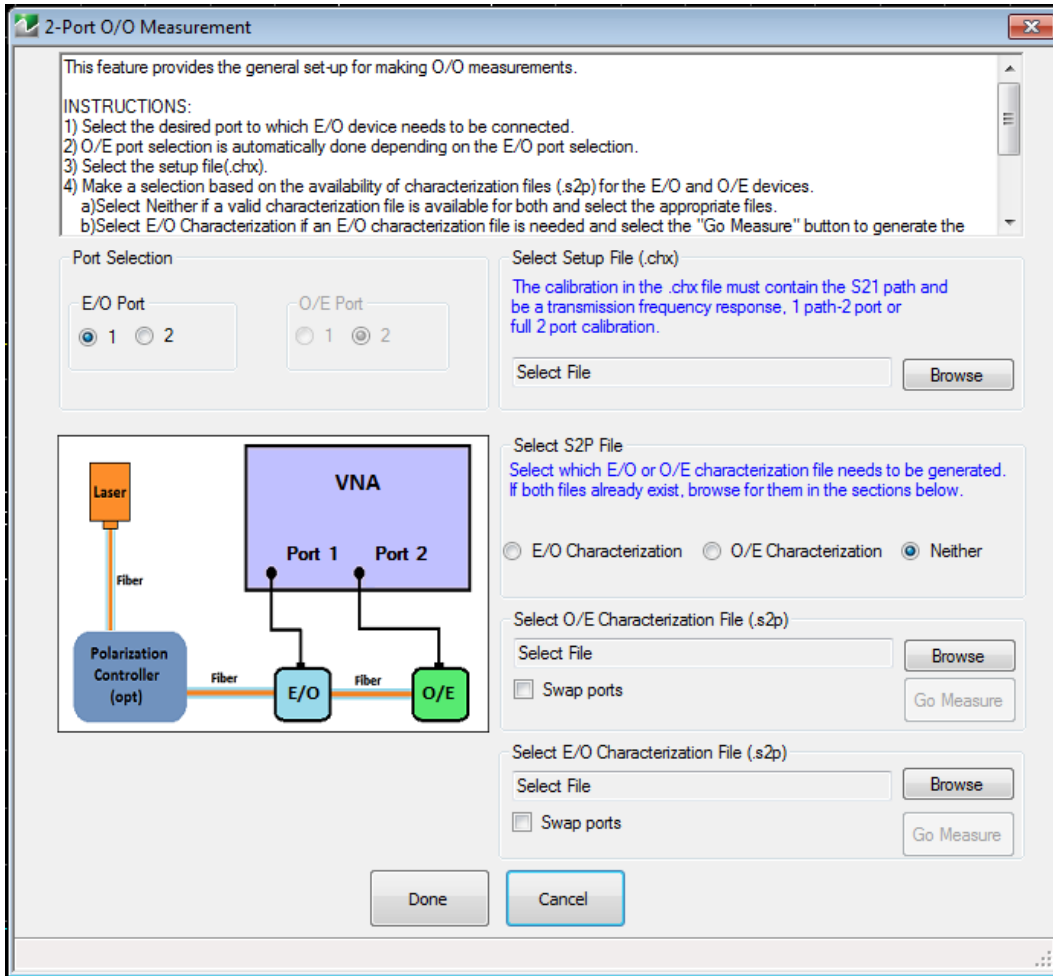

Figure 14-10.2-port O/O Measurements Dialog

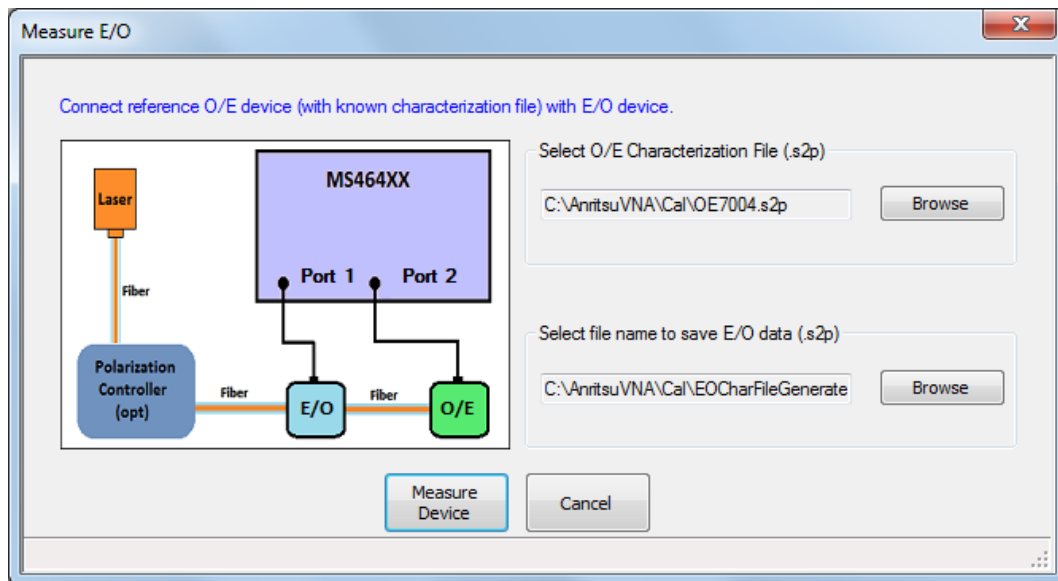

Figure 14-11. Help in Doing the Intermediate Measurement with the Help of the File for a Second Device

When measuring O/O devices, the characteristics of both O/E and E/O devices must be known. If a file for one does not already exist, this dialog can help in doing the intermediate measurement with the help of the file for the other device (usually a calibration O/E device such as the MN4765X). At least one converter must have a .s2p file to do the measurement.

Example E/O Measurement

As an example, consider the following setup:

- 2 GHz to 40 GHz, 10 Hz IFBW, power -20 dBm, no averaging.
- A full two-port SOLT/SOLR calibration is performed using a 3652A Calibration Kit.
- The resulting setup file is saved as setup.chx. This setup file will include all of the above parameters including the calibration data.
- The optical assembly is hooked up with the modulator-under-test connected to Port 1 and an MN4765X O/E calibration module connected to Port 2 of the VNA. The laser is powered up after setting up bias control on the modulator and applying bias to the MN4765X (and, of course, connecting the fiber).
- The E/O measurement utility is invoked using the default port assignment, loading the .chx setup file and loading the characterization file of the MN4765X. Upon selecting Done on the dialog, the resulting S21 measurement reflects the conversion behavior of the modulator and is shown in [Figure 14-12](#). In this case, there is about 10 dB of roll-off over the bandwidth of the measurement.

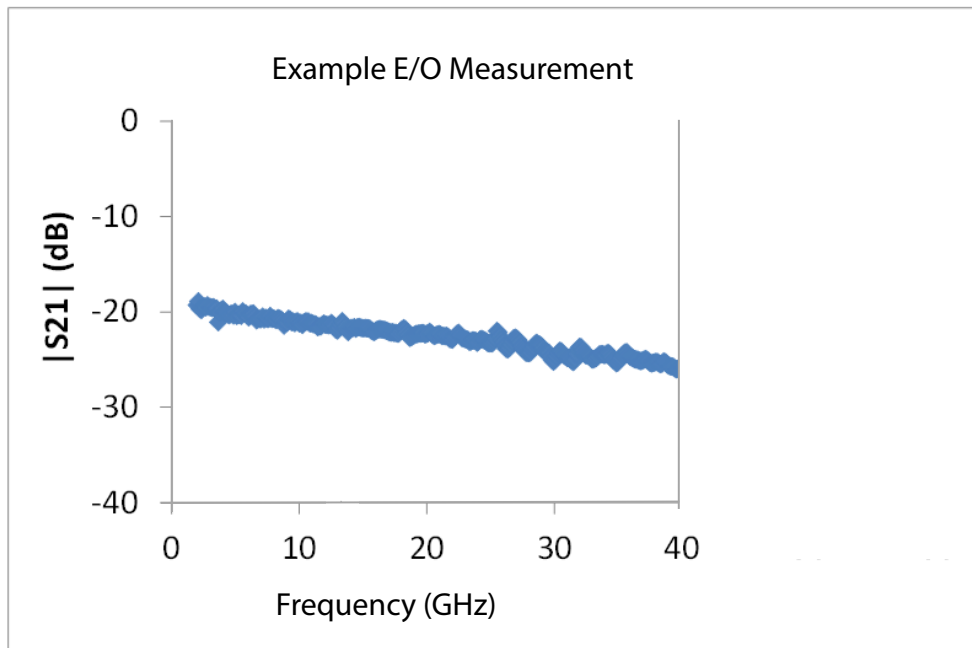

Figure 14-12. Results of an example 2-port E/O measurement using the procedure discussed in the text.

14-5 Uncertainties

In the measurements just described, the uncertainty can be broken into two broad categories:

1. Uncertainty associated with the characterization of the calibration device (such as the MN4765X)
2. Uncertainty in the measurement with the DUT

Typically the user will purchase a characterized photodiode and receive a data file describing that device's transfer function. There is some uncertainty associated with that data based on the characterization technique.

There are different levels of characterization possible. A direct characterization using such optical techniques as electro-optic sampling (e.g., [1]) or the heterodyne method (e.g., [2]) would be termed 1st tier. It is outside the scope of this note to go into detail on these characterization techniques but they are discussed in the references and elsewhere in the literature. These 1st tier characterizations are typically performed at National Metrology Institutes (NMIs, such as NIST or NPL) or large private laboratories.

A 2nd tier standard is characterized by a laboratory based on a 1st tier standard. It would be generated using a process similar to the techniques discussed here but under carefully controlled conditions (bias, temperature, wavelength, etc.) using a 1st tier standard as the characterization device. This 2nd tier device is much more commonly available (the MN4765X is an example) and the uncertainties for a 2nd tier standard will be used in later calculations. The uncertainty penalty in going to 2nd tier device is typically small (on the order of 0.1 dB additional).

When measuring the DUT, there is an uncertainty associated just with the VNA measurement which is discussed elsewhere (e.g., [5]). Since the characterized photodiode response is then de-embedded, the characterization uncertainty must be combined with the VNA measurement uncertainty to obtain an overall value. In the case of an O/E measurement, there are actually two user measurements involved (one with a modulator and the characterized photodiode and one with that modulator and the DUT) so an additional uncertainty must also be included (note the distinction between this second level de-embed and a 2nd-tier calibration device). Typically these uncertainties are all added on a root-sum-square basis since the measurements are assumed to be dominated by uncorrelated quantities.

Before proceeding to some uncertainty values, it may be useful to examine dependencies. On the VNA side, S21 uncertainty is typically quite low for medium power levels but will deviate at high signal levels (receiver compression, not an issue in these measurements) and at low signal levels (effects of the receiver noise floor). Thus the overall uncertainty will be a function of detector output signal level (getting worse as the signal level gets closer to the noise floor). Results can be improved by using higher RF drive levels (keeping all devices linear) and high optical power levels (same caveat). The RF match of the modulator and photodiode will also influence uncertainties to some degree (at all signal levels) but the dependence is relatively weak as long as return loss is better than a few dB.

On the optical side, there is little high level signal dependence as long as the devices are operating linearly. The characterized photodiodes are usually chosen to be very linear over wide power ranges to keep this from being an issue. The characterized detectors typically also have very weak wavelength dependencies; usually less than a few hundredths of a dB over 40 nm. When using a modulator as a transfer standard (as in an O/E measurement), however, it is important that the same wavelength be used in the different measurements with that modulator since much greater wavelength sensitivity usually exists in that component (although this will vary with technology). The use of different VNAs and/or calibration kits may result in slightly different values.

14-6 Summary

The E/O, O/E, and O/O measurement utilities have been discussed in this chapter. This utility is essentially an advanced de-embedding tool allowing one to remove the effects of one optical conversion device to learn the properties of the other. There are a large number of configuration choices, particularly in the 4-port cases, but the measurement principle is the same: use a good VNA calibration to characterize the converting pair and then de-embed the effects of a calibrated/characterized device to analyze the DUT. Signal-to-noise ratio is often a limiting uncertainty factor so it is important to carefully choose drive levels (as high as possible without being nonlinear), IF bandwidth, and averaging in order to optimize the measurements.

14-7 References

1. D. F. Williams, P. D. Hale, T. S. Clement, and J. M. Morgan, "Calibrating electro-optic sampling systems," 2001 Int. Micr. Symp. Dig., pp. 1527-1530, May 2001.
2. P. D. Hale and C. M. Wang, "Calibration Service For Evaluating and Expressing Optoelectronic Frequency Response at 1319 nm for combined photodiode/rf power sensor transfer standards," NIST Special Publ. 250-51, 1999.
3. D. Derickson, Fiber optic test and measurement, Prentice-Hall, pp. 252-263 and 621-638, 1998.
4. J. Hecht, Understanding fiber optics, Prentice-Hall, pp. 28-31, 1999.
5. "What is your measurement accuracy," Anritsu application note 11310-00270, 2001.
6. "E/O and O/E measurements with the 37300c series VNA," Anritsu Application Note 11410-00311, 2003.

Chapter 15 — Maximum Efficiency Analysis (MEA) Measurements

15-1 Overview

The ability to accurately measure maximum efficiency and the kQ product for Wireless Power Transfer (WPT) systems is becoming very important. Anritsu, in collaboration with Toyohashi University of Technology, have provided a measurement system that evaluates the product of the WPT coupling coefficient and quality factor. This kQ product is mathematically related to the maximum efficiency of the WPT and both can be shown in real time.

More and more devices are becoming disconnected from cables as wireless power transfer continues to become a dominant technology. This chapter will discuss some of the measurements of interest, setup considerations, and examples of execution procedures.

15-2 Introduction

The VNA acts as a wireless power transfers system that transfers electromagnetic power from one VNA port to the other VNA port via Transmit/Receive elements.

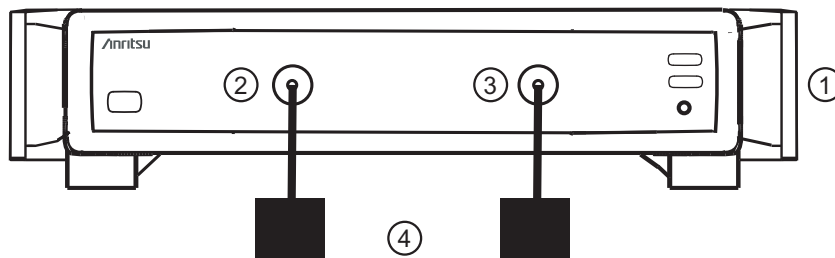

1. ShockLine MS46122A/B or MS46322A/B VNA

2. VNA Port 1

3. VNA Port 2

4. Transmit/Receive Elements

Figure 15-1. 2-Port MEA Measurement Setup

A general 2-port MEA measurement setup is shown in [Figure 15-1](#). The Transmit/Receiver elements are not limited to coils or antennas and can be a device that moves electromagnetic energy.

Software Setup for Maximum Efficiency Analysis

ShockLine software provides a simple interface to setup parameters for Maximum Efficiency Analysis. The initial parameter that must be setup is the Response type. The Response type is not an S parameter but a Z parameter that is mathematically manipulated to provide key parameters for measuring a WPT system. The correct response for this measurement Max Efficiency as shown in [Figure 15-2](#).

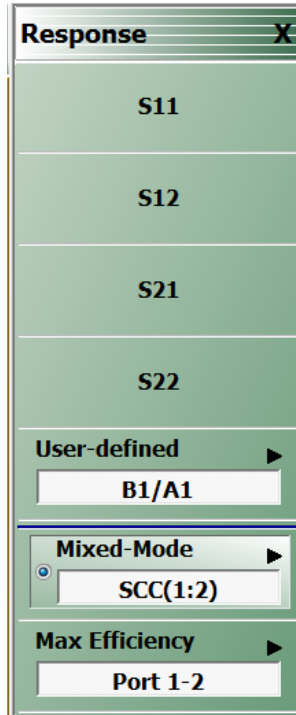

Figure 15-2. RESPONSE Menu with Max Efficiency for WPT

When the Response type has been set to Max Efficiency, ShockLine software enables a set of hidden menus that allows the user to access kQ product and maximum efficiency buttons. This menu is accessible via the ShockLine customized toolbar or through the MAIN MENU function. The DISPLAY menu with enabled Maximum Efficiency Analysis display option is shown in [Figure 15-3](#).

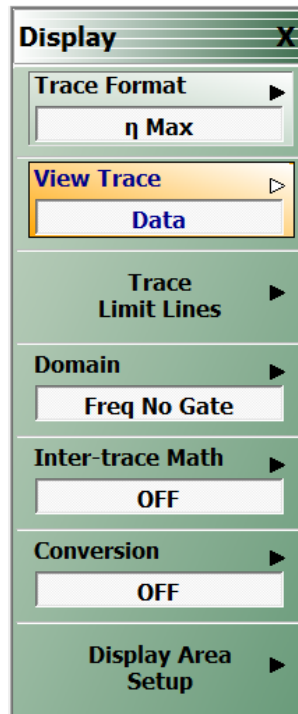

Figure 15-3. Maximum Efficiency Analysis Display

The Display type will be limited to η Max (Maximum Efficiency), kQ or both. The user may want to see one format, the other or both and the measurement data is real time. See the Trace Format options for MEA in [Figure 15-4](#)

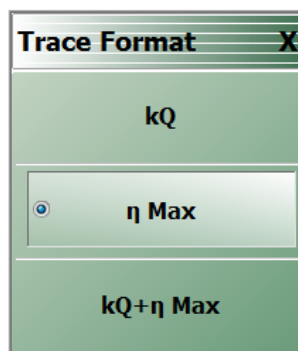

Figure 15-4. TRACE FORMAT Menu

Chapter 16 — MS46131A/ME7868A-Specific Topics

16-1 Overview

The MS46131A and ME7868A series of VNA modules are architecturally unique in that they are single port entities that are synchronizable over significant distances (100 m and more) in the sense of being able to measure transmission phase and be calibrated in a full two-port sense. While these conditions are easily met in an integrated two port (or more) VNA, it has been more of a challenge for remote ports as the measurement synchronization is not trivial to achieve. In the MS46131A family, this is enabled with the PhaseLync option (option 012) that must be installed on both modules. A cable/fiber harness linking the modules is also required that will be described in this chapter. Complete 2-port VNAs using the MS46131A with option 12 and the required PhaseLync cables and accessories are available as complete configurations under the ME7868A part number.

This type of separable VNA modules enables a number of interesting measurement applications including

- Antenna/array/OTA measurements where one port is located at a DUT location and the other is remote for pattern measurements, phase/gain analysis, beam steering studies, and other measurements. Stability and dynamic range of the measurement setup may be important so long cable runs after the test port do not help.
- Materials measurements where the applicator/antenna must be mounted in a complex structure and getting the VNA as close as possible to minimize uncertainties (e.g., large samples, complicated vessels for liquids, ...)
- Any S-parameter measurement where the setup geometry is complicated and may ordinarily require long cable runs from the VNA ports.

This remote module structure raises some important performance behaviors that should be understood in order to maximize performance in a given application. The 1-port alone behaviors are rather similar to the MS46121 family (although the RF component is different, so coverage to 43.5 GHz is available) so this chapter will primarily focus on the impacts on measurements in a more-than-one-port context. Some points about the one-port case (no option 012) are covered in [Appendix A, “MS46131A 1-Port-Only Behavior”](#).

This chapter covers the following topics:

- [Section 16-2 “Background on the Architecture”](#)
- [Section 16-3 “High Isolation Mode and the LO-Generating Module”](#)
- [Section 16-4 “Phase Compensation”](#)
- [Section 16-5 “Gain Ranging”](#)

16-2 Background on the Architecture

Assuming one is not driving both ports simultaneously in some forced phase relationship (not the case for the MS46131A or ME7868A), the main objectives for synchronizing the modules are:

- A common LO for both transmit and receive modules
- A means of sharing the frequency references between modules so the ADC clocks can be synchronous.

The latter objective is met by one module (the Base module that is defined at start-up time) supplying a reference to the other module. This ‘reference’ between the modules forms the frequency reference for the synthesizers as well as providing synchronization at the ADC clock level. Since this reference does not change, the ADC clocks in both modules will remain phase locked to each other. The former objective is met by literally sharing a LO between modules as shown in [Figure 16-1](#). This is possible with an optical link (E/O conversion at one end and O/E conversion at the other) between modules to keep insertion loss to a minimum.

Not all of the details are shown in this figure for simplicity. Each module has a 12V power supply (or battery) and each module has a USB cable to connect to the remote PC. These connections can be achieved through a USB extender or a more complete unit such as the Anritsu MN25131A Multi-function extender that provides the USB relaying and a local battery pack which may be helpful for greater separations between modules (included as part of the system configuration for cables sets of 25 m and longer).

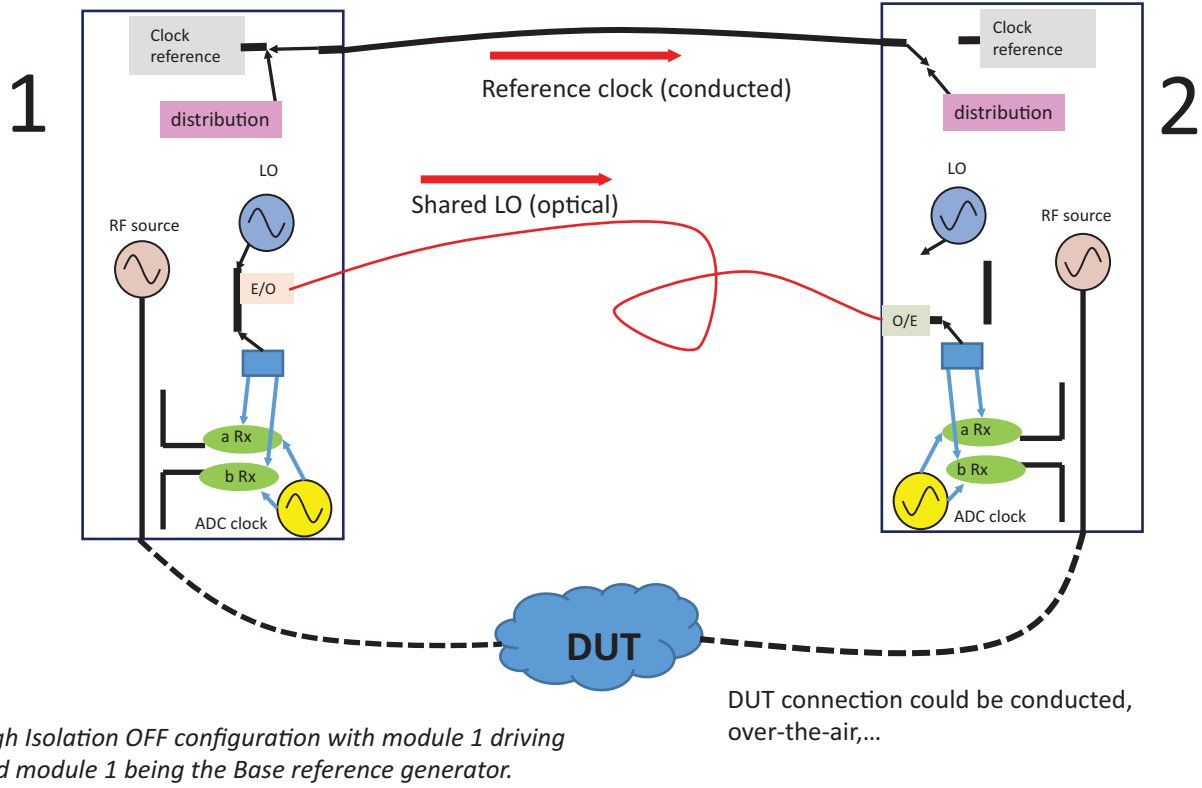

Figure 16-1. The basic assembly of two MS46131A modules with the PhaseLync option is shown here. A cable harness connects the clocking reference (and control signals) from one module to the other (the module sourcing these signals is defined at startup) and an optical fiber allows the sharing of an LO. USB cables connecting each module to the PC (either directly or through an extender) are not shown here.

This LO connection is an analog signal link so the phase and amplitude information embedded in the LO is transferred (although the amplitude information is limited due to a strong limiting operation). While the insertion loss is low in the fiber link, the optical fiber is not immune to dielectric constant changes with temperature and/or flexure (although less than that observed with a typical coaxial cable) so there could be phase shift in the measured transmission response. To understand this, consider how (for example) S₂₁ is constructed from the raw measurement data in an initial state with no LO path electrical length change:

$$S_{21}^{original} = \frac{b_2}{a_1} \approx \frac{Ke^{j\theta_{LO}} B e^{-j\theta_{RF}}}{Ke^{j\theta_{LO}} A e^{-j\theta_{RF}}} = \frac{B}{A}$$

Equation 16-1.

If, now the phase on the LO path between the modules changes by Φ , the relationship changes to

$$S_{21}^{new} = \frac{\widetilde{b}_2}{\widetilde{a}_1} \approx \frac{K e^{j(\theta_{LO} + \Phi)} B e^{-j\theta_{RF}}}{K e^{j\theta_{LO}} A e^{-j\theta_{RF}}} = \frac{B e^{j\Phi}}{A}$$

Equation 16-2.

Had the phase change been common to both the test and reference paths, the phase would have cancelled out. Since the receivers are separate and the longer run exposed, this kind of un-cancelled phase change is a possibility.

There are unique methods on the MS46131A to minimize effects of changes to the link, which will be discussed in a later section. Another aspect is one must choose which module generates the LO for a particular measurement, since each module must be capable of that task (i.e., each module must be capable of performing a one-port measurement). There are different sub-modes that alter the LO-generating module and some resulting trade-offs to consider.

16-3 High Isolation Mode and the LO-Generating Module

In a fully-corrected two-port measurement, the ports alternate in driving the stimulus signal (RF source). The original (now called High Isolation Mode OFF and not the default) LO behavior in the MS46131A pair is that the module providing the port stimulus also provides the LO signal (so it also alternates). Because of the way the RF and LO signals are synthesized, this provides some advantages in high level noise (trace noise).

The sharing that helps trace noise, however, can degrade isolation particularly at lower (<8 GHz) frequencies. Thus a High Isolation mode is available that improves dynamic range (without isolation corrections) to the 100 dB range in a 10 Hz IF bandwidth at the expense of some degradation in trace noise (roughly a doubling). In the High Isolation mode (default), the module that is NOT sourcing the RF signal is used as the LO generator. These two configurations are illustrated in [Figure 16-2](#) for the case when the RF source on module 1 is driving (the LO directions shown in the figures will be reversed for both if the RF source of module 2 is driving). The upper image shows the High Isolation OFF mode and the lower image shows the normal (High Isolation ON) mode configuration.

Note that the Reference clock distribution is independent of the driving port and High Isolation selections (path direction determined by the Base module selection at startup) but the reference is used in slightly different ways in the two modes. This resultant processing change does not visibly affect S-parameter data but does affect unratiod parameter displays (e.g., b2/1 | P1) at IF bandwidths below about 300 Hz and higher IF bandwidths are recommended for those measurements if High Isolation mode is needed with unratiod measurements.

Because of the different signal paths used, a calibration performed in one of these modes cannot be used in the other. A calibration should be performed again (or recalled) when switching between these modes.

The High Isolation mode selection is per-channel and, as such, will be retained in .chx setup files being saved and recalled. The mode is selected on the Sweep Setup menu, as shown in [Figure 16-3](#).

For both modes, if an external reference is used, it must be connected to the Base module since that is the only location that can place the reference onto the line between the modules.

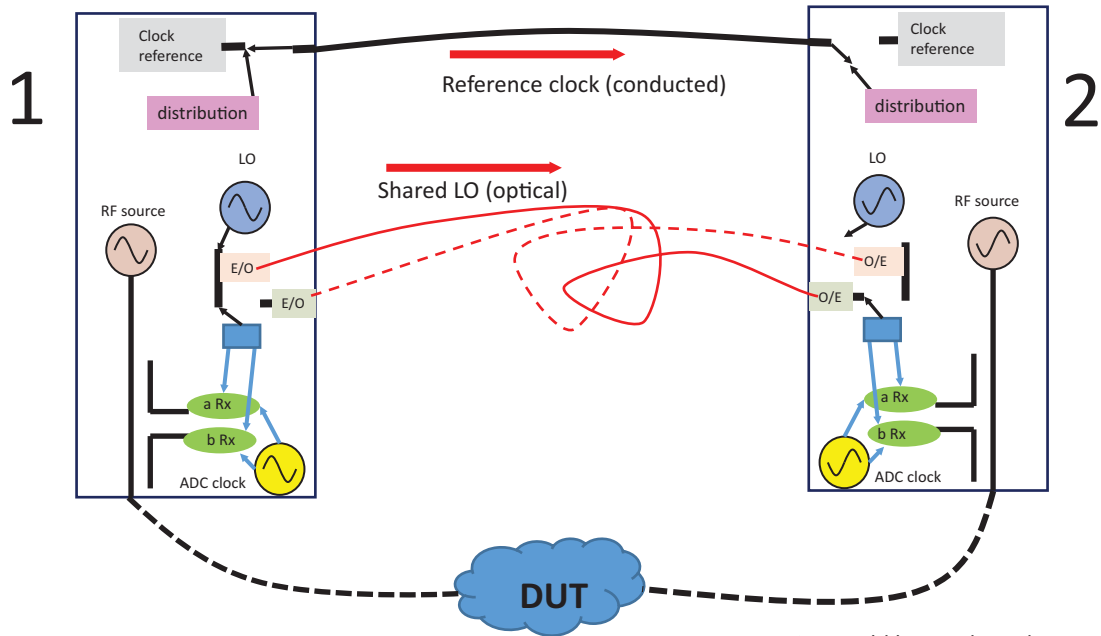

High Isolation OFF configuration with module 1 driving and module 1 being the Base reference generator.

DUT connection could be conducted, over-the-air, ...

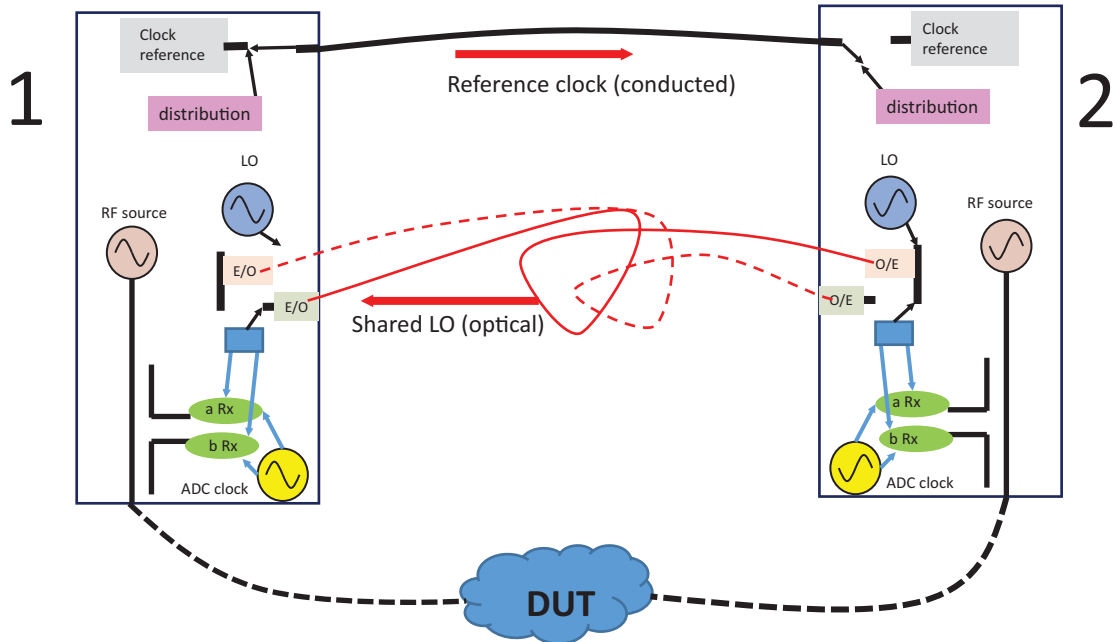

High isolation ON (default) configuration with module 1 driving and module 1 being the Base reference generator.

DUT connection could be conducted, over-the-air, ...

Figure 16-2. 1. The differences in LO sharing between High Isolation OFF (upper image) and High Isolation ON modes (default, lower image) are illustrated here for the case when the RF source of module 1 is driving (e.g., in a S21 or S11 measurement). In the High Isolation OFF case, the module generating the RF stimulus will also provide the LO, but in the High Isolation ON (default) case, the opposite module will provide the LO. The LO is shared over an optical fiber with the help of electrical-to-optical and optical-to-electrical converters at either end.

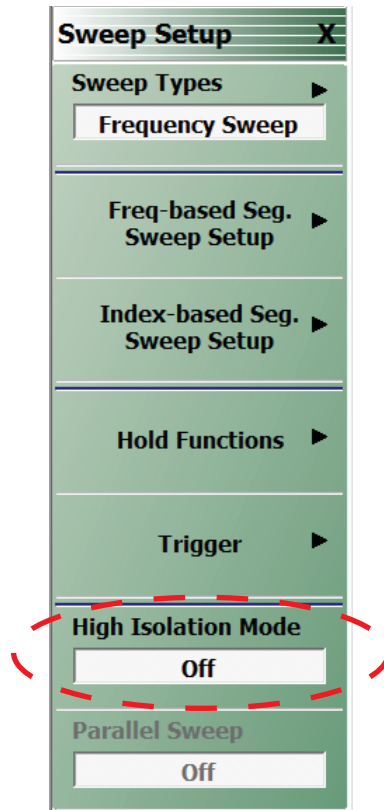

Figure 16-3. The Sweep Setup menu for the MS46131A (with the PhaseLync option and 2 modules connected) is shown here to help illustrate the High Isolation mode switch position.

A further special case relates to those calibrations that make use of switch-term load match corrections (LRL, LRM, TRL, TRM, SOLR, SSLR, and SSSR). In these calibrations, a different configuration is automatically used where the same module is always used for LO generation (the port 2 module by default but this can be changed). This mode is automatically activated when one of the above calibrations is performed or applied. No separate mode selection is needed and the behavior will override any High Isolation selections. This does have the side effect of the instrument behaving like the High Isolation OFF configuration in one transmission direction (generally S12) and like the High Isolation ON in the other direction (generally S21). Those parameter assignments will be reversed if, instead, the port 1 module is chosen to always provide the LO. As with High Isolation mode, unratiod measurements at lower IF bandwidths ($\sim < 300$ Hz) may show distortion with this mode. If unratiod measurements are needed, turning off a calibration of the above type, using a higher IF bandwidth, or performing the unratiod measurement in a separate channel, would be recommended.

16-4 Phase Compensation

Because of the potential large separation of modules (over 100 m in some cases) and the dependence of optical fiber dielectric constant on temperature, pressure, etc., noticeable environmentally-induced phase change is possible. While this might not present too much of a problem in some measurements (e.g., magnitude-only antenna pattern measurements), it can be an issue in others (near-field measurements, for example).

A phase compensation algorithm is available where an additional measurement of just the LO path is made periodically and compared to an initial reference measurement and the phase difference (on a per frequency basis) is computed and used to correct the data. The reference measurement can be re-initialized at any time. In some sense, monitor measurements are used to periodically assess the state (in an electrical length sense) of the optical fiber link. When this mode is turned on and a new user RF calibration is performed, the reference is automatically re-initialized. Again, because it is the relative LO phase between modules that is of concern here, it is mainly transmission phase that is affected. In highly transmissive devices, there is a coupling to load match so reflection measurements in that class can also be affected. The mode switch and the re-referencing button are located on the Calibration menu as suggested in [Figure 16-4](#).

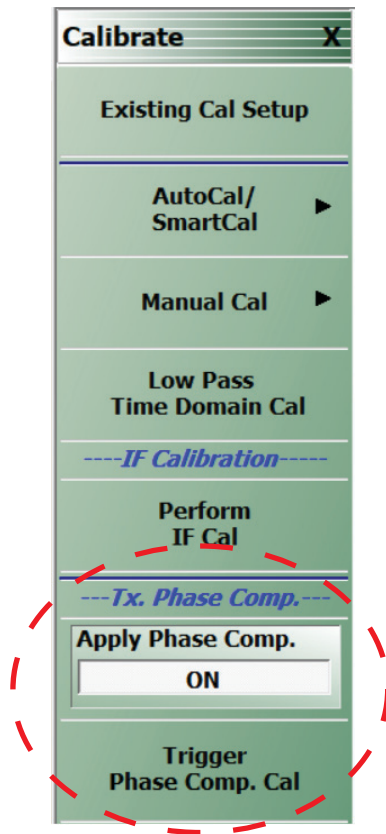

Figure 16-4. The Calibrate menu for the MS46131A (with the PhaseLync option and 2 modules connected) is shown here to help illustrate the position of the Phase Compensation algorithm mode switch and the button to re-reference the phase data.

As an example, consider a setup where a localized cold source is positioned near the optical fiber cable. S21 of a transmissive device is being measured and a reading is taken before the temperature change occurs and then again after a two-second blast of ~ -40 °C cold spray. Admittedly this is not a precise thermal experiment but it is a bounding case on some thermal shock events that can occur in practical measurement setups. The results with and without phase compensation (the optical cable was allowed to return to its initial starting temperature between the experiments) are shown in [Figure 16-5](#). Note that the measurement was done with two different calibrations and at two different points in time but the data is suggestive of the improvement. The algorithm is not limited to handling small phase excursions and can be useful in more thermally and mechanically dynamic environments.

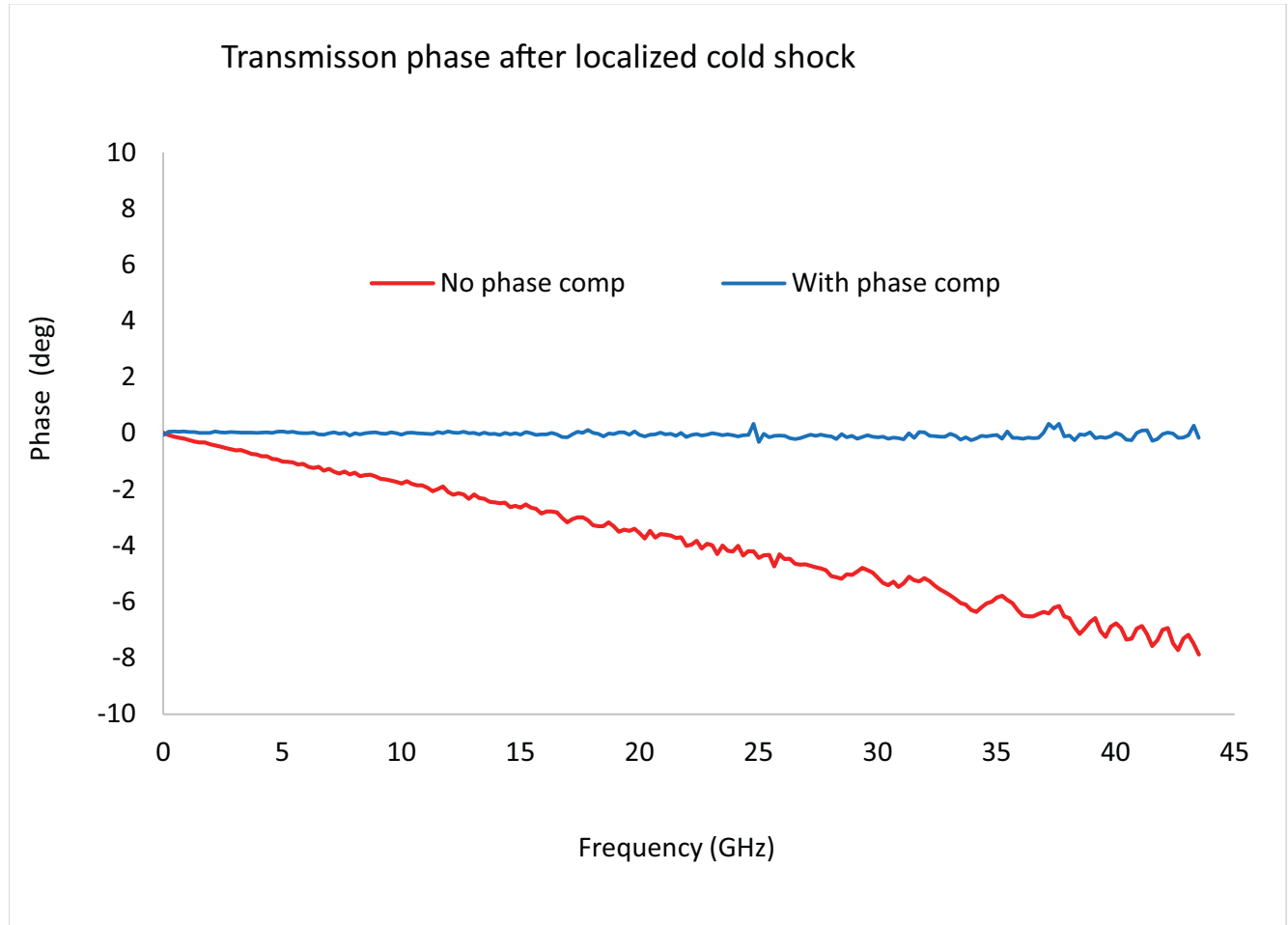

Figure 16-5. A change in transmission phase of a DUT due to a thermal shock on the optical fiber between the two modules is shown here. Without phase compensation, the DUT phase would appear to have moved about 8 degrees at 43 GHz due to that distortion. With phase compensation active, the distortion was considerably less than 1 degree at 43 GHz.

It should be pointed out that, had conventional coaxial cables been used between the modules, not only would the separation distance have been more limited (due to cable loss) but the temperature sensitivity could have been similar or greater.

A second-order effect (and only relevant for very low loss, well-matched devices) is a load match change as that interacts with the transmission parameters within a calibration. The effect on that parameter with the same chilling experiment is shown in [Figure 16-6](#) expressed in vector-delta form. The magnitude of the effect is small.

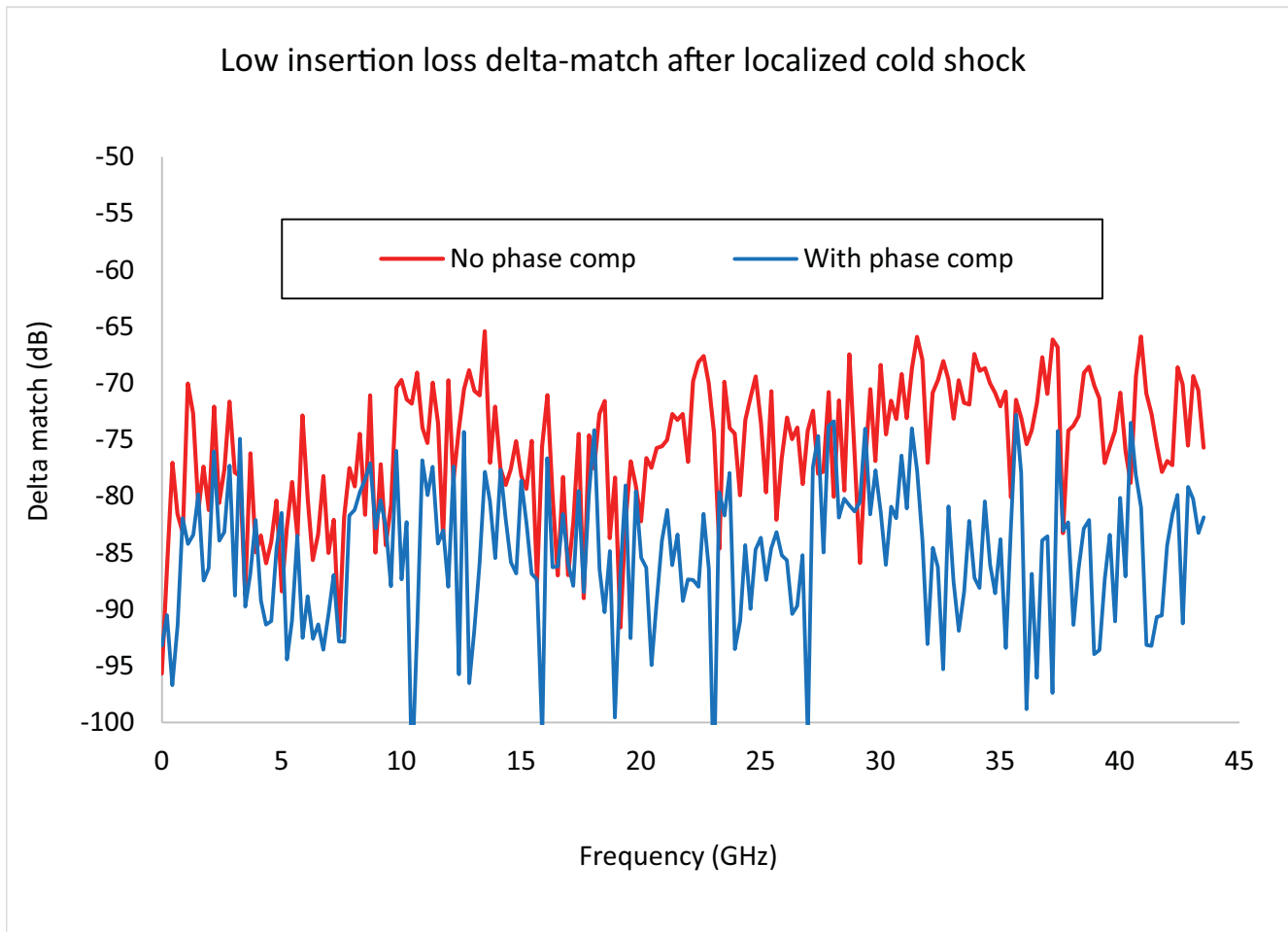

Figure 16-6. The effect on load match is plotted here for the same thermal shock experiment of [Figure 16-3](#). This is a second-order effect but one can see the phase compensation algorithm is able to somewhat reduce the vector match error. It should be emphasized that this level of correction will not impact many common measurements.

In a more conventional 5 °C temperature-rise type of experiment, the same kind of phase change relationship was observed although the size of the deviations are smaller (see Figure 16-7). The phase compensation algorithm reduced the apparent distortion from about 5 degrees at 43 GHz to much less than 1 degree. As these are all electrical length effects, the size of the potential phase distortion will scale roughly linearly with frequency. In all of these experiments, the magnitude of the transmission parameter was not significantly affected since (a) the LO amplitude is largely saturated and (b) only the effective dielectric constant of the path was being changed by the perturbation.

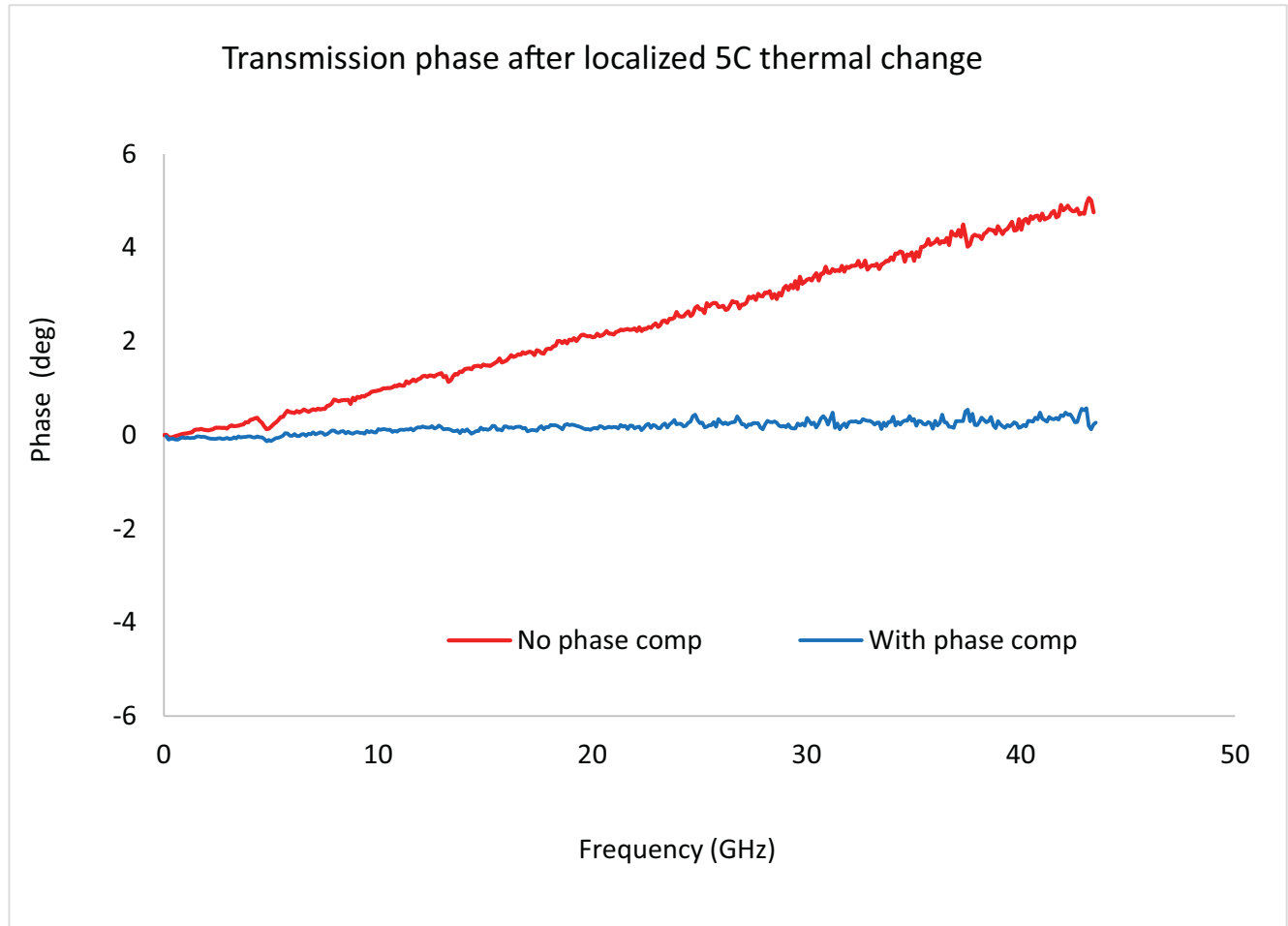

Figure 16-7. The effect of phase compensation on a DUT measurement when the temperature changed by about 5 °C is shown here. The fiber was 1 m long in this case and the differences would be proportionately larger for longer fiber runs.

Because of the measurement of monitoring signals to check for phase shift in the LO path, the phase compensation does result in a reduction in sweep speed. With phase compensation applied, the sweep time increases by a value on the order of a millisecond per point (independent of IF bandwidth settings).

16-5 Gain Ranging

There are certain cases, particularly when measuring very lossy devices or lossy paths in over-the-air test, when having added IF gain would be beneficial. Increasing gain dynamically at low signal levels allows one to stay out the less linear region of an analog-to-digital converter's (ADC's) response. This non-linearity arises in part from the discrete nature of ADC output that becomes visible with small signals and the slight imprecision in those levels (termed integral nonlinearity).

When Gain Ranging is turned on, additional IF gain is automatically added when the detected b1 or b2 signal levels get below a certain threshold. Then this gain change value is numerically removed from the data so the displayed values are correct. By staying out of the lower part of the ADC response, this can improve absolute accuracy on high loss measurements (generally when the transmission coefficient is under -40 dB when in high power mode).

A potential downside is that the gain decision is based on the signal level at the desired frequency. If interfering signals are present (in OTA test sometimes) or the signal being measured is not the dominant one (making distortion measurements, for example), then the decision could be incorrect and result in the ADC being overloaded. Also, sweep time will be increased to support the gain decision making. Thus, the ability to turn gain ranging off is provided for these cases.

Appendix A — MS46131A 1-Port-Only Behavior

When the PhaseLync option (option 012) is not enabled in both MS46131A modules (and/or the synchronizing cable is not connected at application launch), the system behaves as one or two 1-port VNAs. In this sense, the modules become similar to the MS46121X family, except with a higher potential frequency range and different hardware performance levels. There are some aspects related to one-port only operation that may be obvious:

- Only full 1-port and reflection response calibrations are available
 - If a transmissive device is connected between two MS46131A modules operating in 1-port-only mode, the measured reflection will be a combination of the other module's raw (not corrected) load match and the DUT parameters. As a result, the measured match will likely be worse than the true S11 of the DUT (unless the DUT is relatively lossy).
- Embedding/De-embedding and network extraction options are limited in the 1-port-only operating mode.
 - Reference plane extension (including with loss) is available
 - The main embedding/de-embedding engine is available when a full one-port calibration is active. The usual primitives and .s2p files can be used but, of course, only the reflection parameter will be affected.

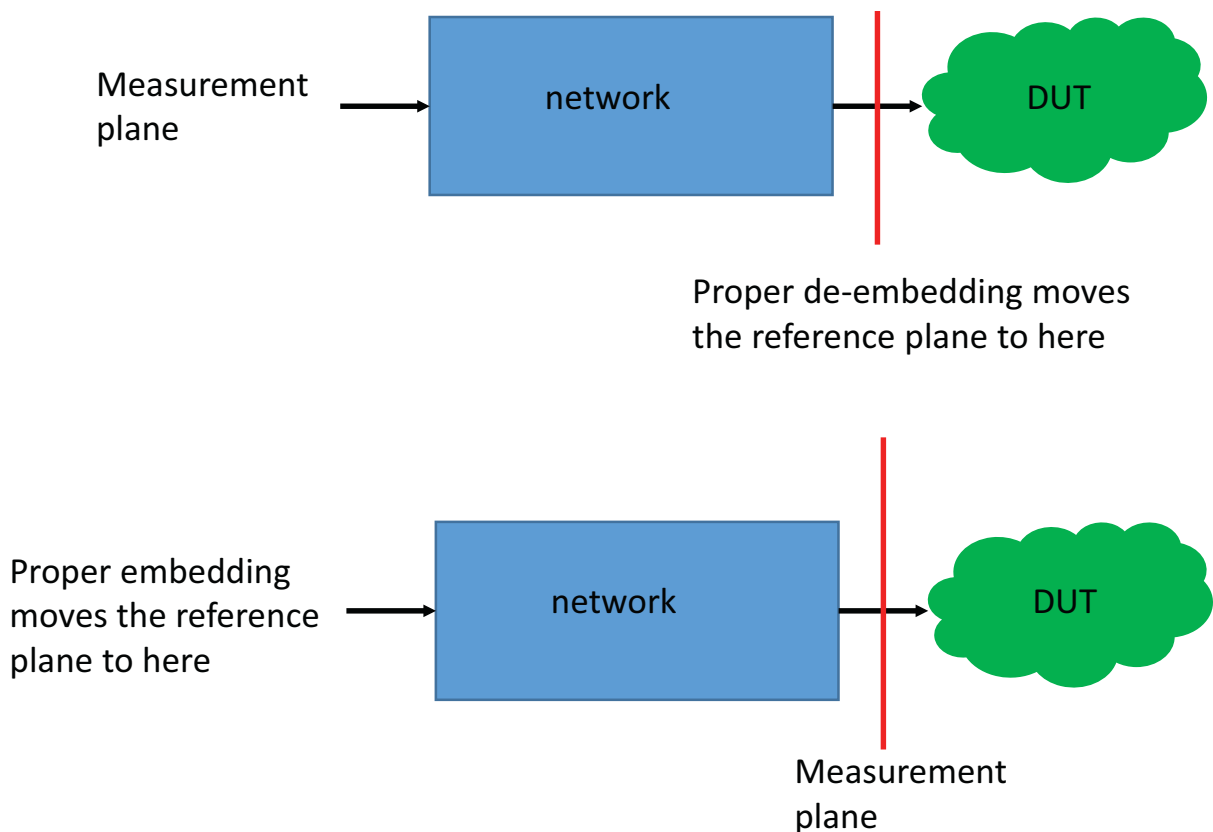

Figure A-1. De-embedding and Embedding are allowed with the 1-port instruments, but only affect reflection measurements.

- Type B network extraction (the Bauer-Penfield approach relying on two one-port calibrations on different planes) (see [Figure A-2](#)) is the only extraction tool available (as all others require multiport calibrations).

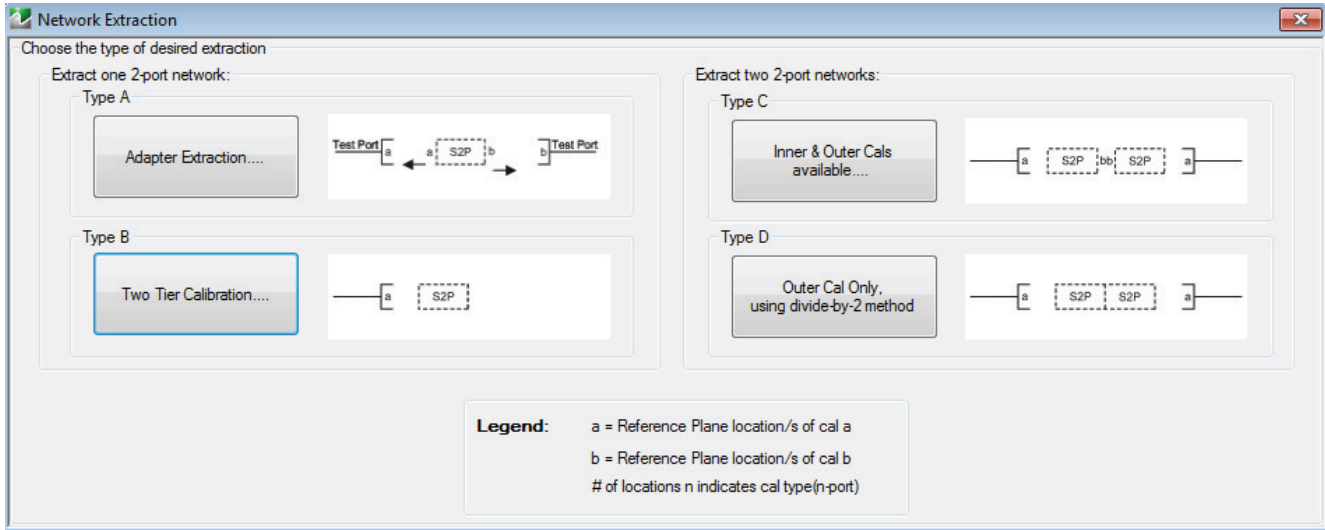

Figure A-2. Network Extraction for MS46131A 1-Port-Only Mode

- While the MS46121X product has an available option for scalar transmission measurements, this is not available with the MS46131A (since a vector transmission measurement, which has inherently better range and accuracy than a scalar measurement, is available with the MS46131A).
- The MS46121X product allows the connection of 16 modules to a single computer where each module is assigned to a different channel. Currently, only two MS46131A modules can be connected to a single PC but they are allowed to operate within the same channel or channels.
 - Thus one can do a double 1-port calibration with the two MS46131A modules and perform two 'simultaneous' one-port measurements.

Index

Numerics

1 Path 2 Port 1-9
 20 dB attenuator 10-4
 2-Port Mode 1-9, 1-10

A

Adapter removal 2-7, 2-31, 7-1
 Adapter Removal Calibrations 7-1
 Airline 10-4
 Anritsu Part Numbers
 3650x SOLT Kits 1-7
 3655X Kit 1-7
 36585K-2F Precision AutoCal 2-5
 36585K-2M Precision AutoCal 2-5
 36585K-2MF Precision AutoCal 2-5
 36585V-2F Precision AutoCal 1-3, 2-5
 36585V-2M Precision AutoCal 1-3, 2-5
 36585V-2MF Precision AutoCal 1-3, 2-5
 3668-1 Verification Kit 10-1
 3669B-1 Verification Kit 10-1
 36804-XXX Fixture 1-7

AutoCal

 Adapter removal 2-7, 2-31
 Characterization file 2-12
 Description 1-6
 Port auto-sense 2-2
 AUTOCAL CHARAC. menu 2-29, 2-30
 AutoCal Modules 2-2, 2-5
 Auto-sense 2-2
 Averaging 1-10, 11-26, 13-3
 AVERAGING menu 11-26

B

Bandpass mode 12-11
 Beatty airline 10-4

C

CAL KIT menu 1-7, 2-12
 CAL METHOD menu 6-7
 CAL OPTIONS menu 8-3, 8-12
 CAL SETUP menu 6-7
 CALIBRATE menu 6-7, 16-6
 Calibration
 LRL/LRM 6-1
 Calibration - Full Two Port - Internal Through 2-17
 Calibration - Two Port Cal - True Through 2-22
 Calibration kits 1-3
 CALIBRATION menu 6-7
 CALIBRATION TR menu 6-9
 Calibrator Modules 2-4
 CHAN. LAYOUT menu 11-4
 CHANNEL menu 11-3
 Channels and Traces Introduction 11-1
 Characterization 2-2, 2-29

Characterization File 2-2, 2-12
 Chirp-Z transform 12-3
 Complex Trace 11-9
 Connect the True Through 2-26
 Connector care 2-6
 CONVERSION menu 9-17
 Conversion mode
 Of reflection/transmission 9-17
 Coplanar waveguide 1-7
 Creation of verification kit 10-3

D

DC TERM menu 12-7
 De-embedding 7-1, 7-9, 9-1
 DENOMINATOR menu 11-25
 Dielectric constant 1-13
 DIELECTRIC menu 9-2
 Directivity 1-8, 1-12, 5-1
 Dispersive media 1-13
 DISPLAY menu 9-17, 11-8, 15-3
 DOMAIN menu 12-2, 12-11

E

E/DE (Embedding/De-embedding) 9-1, 9-11
 E/O and O/E Converter 14-1
 Effects of fixtures 7-1
 Electrical to Optical Measurements 14-1
 Embedding 9-1
 Embedding and De-Embedding 7-9
 EMBEDDING menu 9-4
 Equation Editor 11-10, 11-11
 Extraction, Network 7-9
 EXTRAPOLATION menu 12-7

F

Fast Fourier Transform 12-3
 Fixed load 3-1
 Fixtures 7-1
 FREQ BASE SETUP menu 13-4
 FREQUENCY menu 2-15
 Frequency response 1-8, 1-9
 Frequency-Based 13-3
 Full 1-Port 1-9
 Full 2-Port 1-9

G

Gain Ranging 16-9
 GATE FUNCTION menu 12-16
 GATE SETUP menu 12-15
 Gating 12-15
 GPC-7 connector 10-5
 Graph mode 13-5

H

High isolation mode 16-3

Hold Functions	11-5
HOLD FUNCTIONS menu	11-19

I

IF Bandwidth (IFBW)	1-10, 2-14
IMPED. TRANSF. menu	9-2, 9-14
Impedance Transformation	9-1, 9-2, 9-14
Impulse functions	12-3
INDEX BASE SETUP menu	13-7
Index-Based	13-3
Index-Based Segmented Sweep	13-7
Insertable	2-2
Internal Through	2-2, 2-17
Interpolation	8-2
Inter-Trace Math Equation Editor	11-10
INTER-TRACE MATH menu	11-11
Isolation	1-13
ISOLATION menu	6-9

L

Limit lines	11-20
LIMIT menu	11-20
Line length	6-1
LINE TYPE menu	6-7
Linear	13-2
LINES/MATCHES menu	6-9
Load	3-1
Load match	1-12
Log	13-2
LO-generating module	16-3
Low pass mode	12-4
LRL (Line-Reflect-Line)	6-1
LRM (Line-Reflect-Match)	6-1

M

MAIN menu	11-7, 11-8
MANUAL CAL menu	6-7
Match	1-8
MAX EFFICIENCY menu	11-25
Maximum Efficiency Analysis	15-1, 16-1
MEA Measurements	15-1
MEASUREMENT menu	9-2
Measurement setup	11-1
Measurements/(O/E-E/O)	14-7
Microstrip	1-7
MIXED MODE menu	11-25

N

National Institute of Standards & Technology	1-4
--	-----

Network Extraction	7-9
Sequential Extraction	7-38
Type A	7-11
Type B	7-13
Type B—Flex Standards (with Option 24)	7-15
Type B—Full Standards	7-13
Type C	7-23
Type D	7-25
Type D—Multi-Standards (with Option 24)	7-26
NIST	1-4
Non-insertable	2-2
Notch	12-16
NUMERATOR menu	11-25

O

O/E-E/O menu	9-2
OE-EO	
Example 2-Port Procedures	14-10
Example 4-Port Procedures and Variations	14-17
Measurement Concepts	14-2
Measurements	14-1
Offset length	6-6
Opens	3-1
OPTICAL MEAS. menu	14-7, 14-10
Optical to Electrical Measurements	14-1

P

Peeling	7-38
Phase compensation	16-5
PhaseLync option (option 012)	16-1
Phasor impulse	12-13
Pin depth	1-15
Point-by-Point	1-10
Port auto-sense	2-2
Port Power	13-3
Power	1-10
POWER COUPLED menu	13-2
POWER SETUP menu	13-3
Precision AutoCal Module	1-6
PROCESSING ORDER menu	9-2, 9-16

R

RANGE SETUP menu	12-5, 12-13
Reciprocal	3-1
Reference plane	9-12
Reference plane control	9-1
REFERENCE PLANE menu	9-2
Reflection	6-6
Response	1-11
SSST reflection	5-1
Tracking	1-12
REFLECTIVE menu	6-9
Reflectivity Error Terms	5-1
Re-reference phase data	16-6
Resolution	12-5
RESPONSE menu	11-25, 15-2
Round trip	12-3

S	
Sequential Extraction, Peeling (with Option 24)	7-38
ShockLine	1-1
Shorts	3-1
Sliding load	3-1
SmartCal Modules	2-2, 2-5
SMARTCAL SETUP menu	2-21
Smoothing	11-26
SnP FILES SETUP menu	12-21
SOLT (Short-Open-Load-Through)	1-7, 1-9, 3-1
Source match	1-12
SSLT (Short-Short-Load-Through)	4-1
SSST (Short-Short-Short-Through)	1-9, 5-1
SSST Calibration Example	5-4
Standard AutoCal Module	1-6
Sweep	
Sweep frequency	13-1
Sweep types	13-1
Sweep-by-Sweep	1-10
SWEEP SETUP menu	13-1, 16-5
Synchronizing 1-port VNAs	16-1
T	
Through	2-2
Through, internal	2-2, 2-17
Through, True	2-2
Thru	2-2, 3-1, 8-1
THRU menu	8-1
Thru update	8-1
TIME DEFINITION menu	12-3
Time domain	12-1
Time domain modes	12-2
TRACE FORMAT menu	11-8, 15-3
TRACE LAYOUT menu	11-7
TRACE menu	11-6, 11-7
Transfer calibration	2-1
Transmission	
Frequency response	1-11
Tracking	1-12
Triple Offset Short	5-1
True Through	2-2
TWO PORT CAL menu	6-9
TWO PORT CAL/S menu	6-7
Type A—Two Full 2-Port Cals	7-10
Type B—Extraction With Flex Standards	7-10
Type B—Two Tier Two 1-Port Cals	7-10
Type C—Inner and Outer Cal	7-10
Type D—Extraction—Phase Localized	7-10
Type D—Outer Cals (Multi-Standards)	7-10
U	
Update through	8-1
USB	2-12
USER DEFINED menu	11-25
UTILITY menu	2-29, 2-30
V	
Verification kits	1-3, 10-1
Verification process	10-1, 10-3
W	
Waveguide	3-3
Waveguide kit	1-7
Window	12-8
WINDOW SHAPE menu	12-8

Anritsu



Anritsu utilizes recycled paper and environmentally conscious inks and toner.

Anritsu Company
490 Jarvis Drive
Morgan Hill, CA 95037-2809
USA

<http://www.anritsu.com>