

365xx-x Mechanical Calibration Kits

- 365xx** Cal Kit with Pin Depth Gauge
- 365xx-2** Cal Kit with No Pin Depth Gauge
- 365xx-3** Cal Kit with Pin Depth Gauge and s1p Characterization
- 365xx-4** Cal Kit with No Gauge and s1p Characterization



NOTICE

Anritsu Company has prepared this manual for use by Anritsu Company personnel and customers as a guide for the proper installation, operation and maintenance of Anritsu Company equipment and computer programs. The drawings, specifications, and information contained herein are the property of Anritsu Company, and any unauthorized use or disclosure of these drawings, specifications, and information is prohibited; they shall not be reproduced, copied, or used in whole or in part as the basis for manufacture or sale of the equipment or software programs without the prior written consent of Anritsu Company.

UPDATES

The latest service and sales contact information, and updated documents can be downloaded from the Anritsu Website at: <http://www.anritsu.com>

Table of Contents

1—Calibration Kit Descriptions

1-1	Introduction	1-1
1-2	Related Documentation	1-1
	Product Information, Compliance, and Safety	1-2
1-3	Contacting Anritsu	1-2
1-4	Kit Descriptions	1-3
	Model 3650A – 3.5 mm Connector Calibration Kit	1-3
	Model 3651B – GPC-7 Connector Calibration Kit	1-5
	Model 3652A – K Connector Calibration Kit	1-6
	Model 3653A – N Connector Calibration Kit	1-8
	Model 3654D / 3654D-x – V Connector Calibration Kit	1-10

2—Connector Pin Depth Measurement

2-1	Introduction	2-1
	Pin Depth Defined	2-2
	Pin Depth Limits	2-3
	Reading Pin Depth	2-4
2-2	Pin Depth Gauging Procedures	2-5
	Model 3650A – 3.5 mm Connector Pin Depth Measurement	2-5
	Model 3651A – GPC-7 Connector Pin Depth Measurement	2-6
	Model 3652A / 3652A-X – K Connector Pin Depth Measurement	2-7
	Model 3653A – Type N Connector Pin Depth Measurement	2-8
	Model 3654D / 3654D-X – V Connector Pin Depth Measurement	2-9

3—Maintenance Instructions

3-1	Introduction	3-1
	Common Causes of Connector Failure	3-1
	Coaxial Connector Care	3-1
3-2	Visual Inspection	3-2
	Outer Conductor and Thread Inspection	3-2
	Center Conductor Inspection	3-3
3-3	Connector Cleaning	3-4
	Required Cleaning Items	3-4
	Procedure	3-5
3-4	Making a Connection	3-7
	Before Connection	3-7
	Initial Connection	3-7
	Torquing the Connection	3-9
	Torque Specifications and Tools	3-10
	Disconnection	3-11
	Connector Types and Cross-Mating Compatibility	3-11



Chapter 1 — Calibration Kit Descriptions

1-1 Introduction

Calibration kits contain components used to identify and separate error sources inherent in microwave test setups. The kits described in this document contain all of the precision components and tools required to calibrate Anritsu Vector Network Analyzer (VNA) systems for error corrected measurement. Included are memory devices which provide coefficient or measurement data for each component.

These kits are applicable to the MS464xA/B Series VNA and the Lightning 37xxxD/E Series VNA.

Note	Options 3 and 4 are applicable only to MS464xA/B, and .s1p characterization is not supported by Lightning 37xxxD/E.
-------------	---

This chapter provides illustrations and a list of contents for each calibration kit. [Chapter 2](#) provides connector pin depth measurement instructions and [Chapter 3](#) provides maintenance instructions applicable to the kits. Use of the mechanical calibration kits is described in the Measurement Guide or Operation manual for each VNA.

Note	All components in these kits are of the highest quality and accuracy and are NMI (National Metrology Institute) and NIST (National Institute of Standards and Technology) traceable. Mechanical shock can damage them. Handle with care.
-------------	--

Table 1-1. Kit List with Connector Type and Option Applicability

Cal Kit Model-Option	Connector Type	Additional Option Applicability	
		Pin Depth Gauge	.s1p Characterization
3650A	3.5 mm	Yes	
3651B	GPC-7		
3652A	K	Yes	
3652A-2	K		
3652A-3	K	Yes	Yes
3652A-4	K		Yes
3653A	N	Yes	
3654D	V	Yes	
3654D-2	V		
3654D-3	V	Yes	Yes
3654D-4	V		Yes

1-2 Related Documentation

All the latest product documentation related to the VectorStar MS464xB Series VNA is accessible at Anritsu's Web site at:

<http://www.anritsu.com/test-measurement/products/ms4640b-series>

On this web page, you can select various tabs for more information about your instrument. Included is a “Library” tab which contains links to all the latest technical documentation related to this instrument.

Product Information, Compliance, and Safety

Refer to the VectorStar Product Information, Compliance, and Safety (PICS) – 10100-00063 for applicable product information, compliance statements, and safety information, including links to applicable product web pages.

1-3 Contacting Anritsu

To contact Anritsu, please visit:

<http://www.anritsu.com/contact-us>

From here, you can select the latest sales, service and support contact information in your country or region, provide online feedback, complete a “Talk to Anritsu” form to get your questions answered, or obtain other services offered by Anritsu.

1-4 Kit Descriptions

Model 3650A – 3.5 mm Connector Calibration Kit

The 3650A Calibration Kit contains all the precision components and tools required to calibrate VNAs with error-corrected measurements for test devices with 3.5 mm connectors. Components are included for calibrating both male and female test ports. The kit supports calibration with broadband loads. See [Table 1-1 on page 1-1](#) for additional component option applicability.

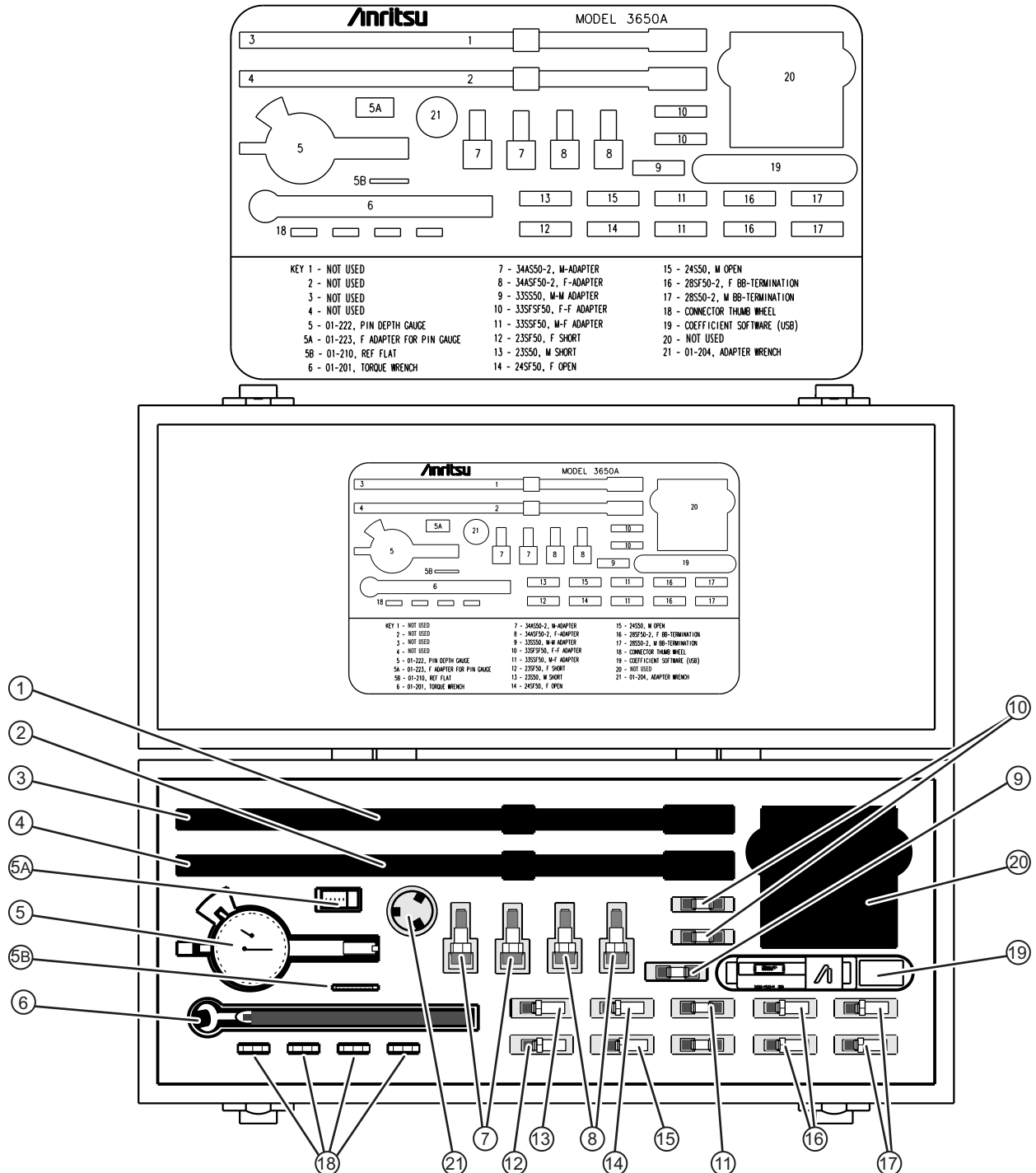

Figure 1-1. Model 3650A – 3.5 mm Connector SOLT Calibration Kit (1 of 2)

1	Not Used (Sliding Loads no longer available.)
2	Not Used (Sliding Loads no longer available.)
3	Not Used
4	Not Used
5	01-222 Pin Depth Gauge
5A	01-223 Female Adapter for Pin Depth Gauge
5B	01-210 Reference Flat for Pin Depth Gauge
6	01-201 5/16" (8 mm) Torque End Wrench, set to 8 lbf·in (0.9 N·m)
7 ^a	34AS50-2 GPC-7 to 3.5 mm Male Adapter (2 each)
8 ^a	34ASF50-2 GPC-7 to 3.5 mm Female Adapter (2 each)
9	33SS50 Male-Male Phase Equal Adapter
10	33SFSF50 Female-Female Phase Equal Adapter (2 each)
11	33SSF50 Male-Female Phase Equal Adapter (2 each)
12	23SF50 Female Short
13	23S50 Male Short
14	24SF50 Female Open
15	24S50 Male Open
16	28SF50-2 Broadband Female Termination (2 each)
17	28S50-2 Broadband Male Termination (2 each)
18	A18311 Connector Thumb Wheel (4 each)
19	Calibration Component Coefficients on USB Memory Device
20	Not Used
21	01-204 Universal Adapter Wrench

Figure 1-1. Model 3650A – 3.5 mm Connector SOLT Calibration Kit (2 of 2)

- a. Starting with kit serial number 1644002, part numbers 34AS50-2 and 34ASF50-2 (3.5 mm to GPC-7 Adapters) are not supplied with the 3650A/3650A-1 calibration kits.

Model 3651B – GPC-7 Connector Calibration Kit

The 3651B Calibration Kit contains all the precision components and tools required to calibrate a VNA with error-corrected measurements for test devices with GPC-7 connectors. The kit supports calibration with broadband loads.

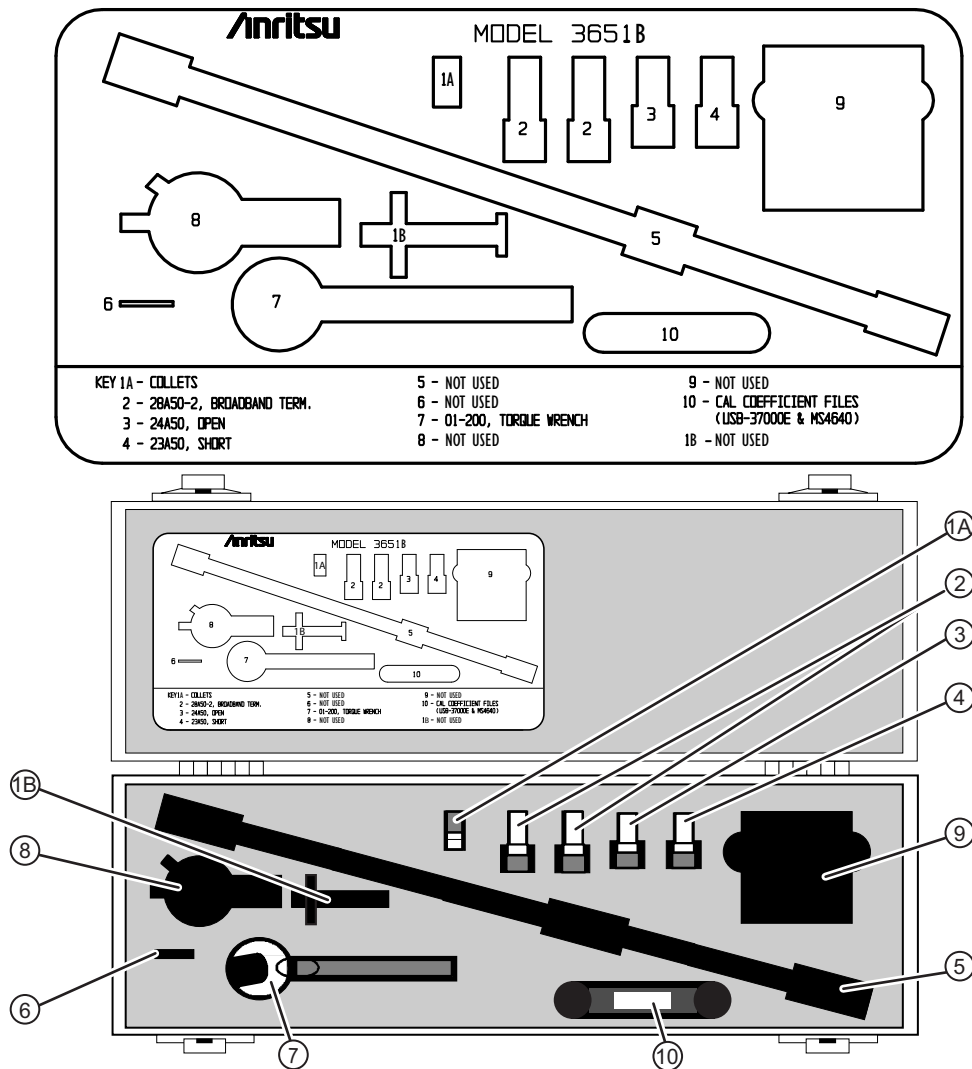

1	Collets (4 each)
2	28A50-2 Termination, DC to 18 GHz (2 each)
3	24A50 Open
4	23A50 Short
5	Not Used (Sliding Loads no longer available.)
6	Not Used
7	01-200 3/4" Torque End Wrench, set to 12 lbf·in (1.36 N · m)
8	Not Used
9	Not Used
10	Calibration Component Coefficients on USB Memory Device

Figure 1-2. Model 3651B GPC-7 Connector SOLT Calibration Kit

Model 3652A – K Connector Calibration Kit

The 3652A/3652A-x Calibration Kits contain all the precision components and tools required to calibrate a VNA with error-corrected measurements for test devices with K Connectors. Components are included for calibrating both male and female test ports. The kit supports calibration with broadband loads. See [Table 1-1 on page 1-1](#) for additional component option applicability.

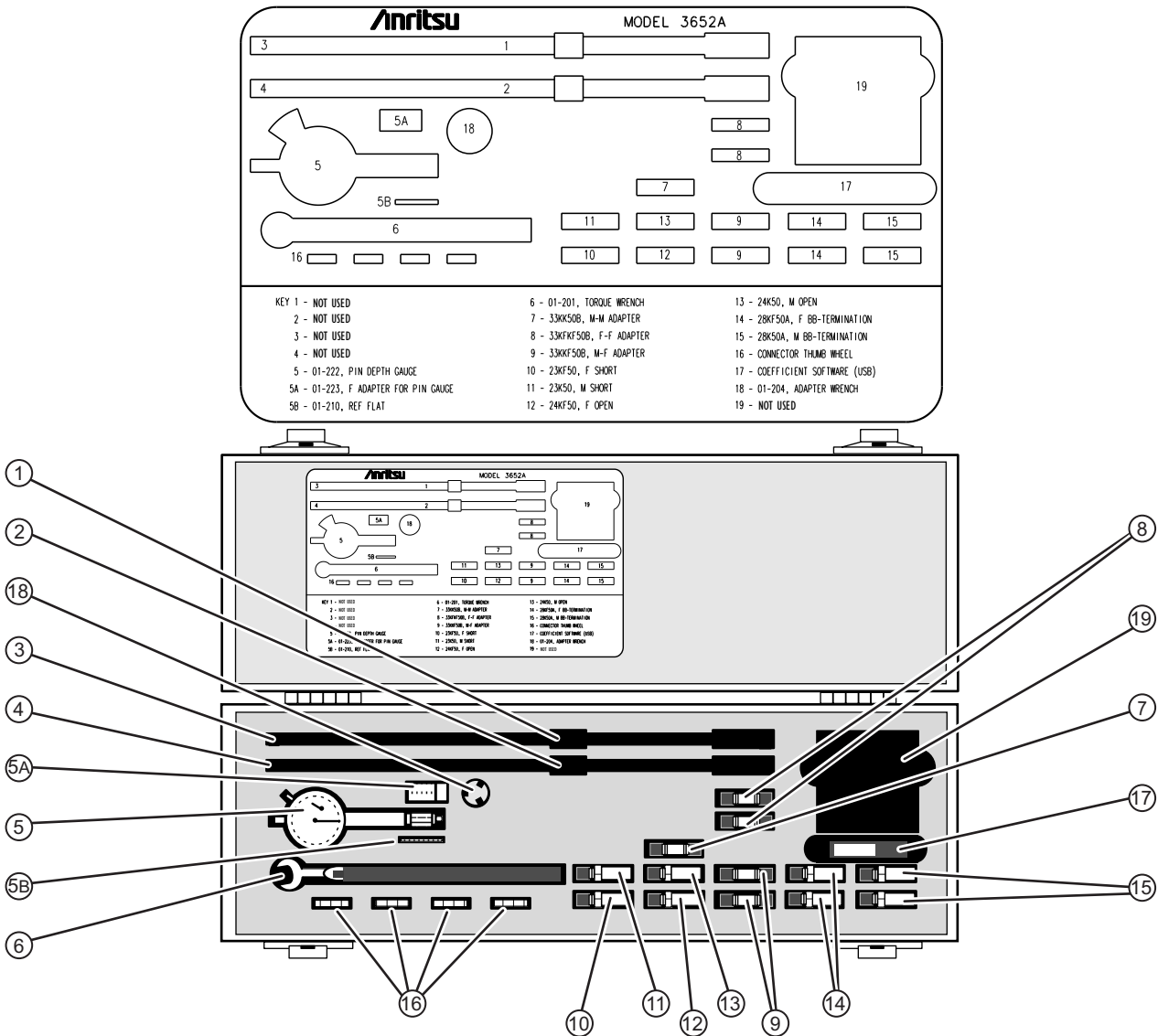

1	Not Used (Sliding Loads no longer available.)
2	Not Used (Sliding Loads no longer available.)
3	Not Used
4	Not Used
5	01-222 Pin Depth Gauge (3652A, 3652A-3)
5A	01-223 Female Adapter for Pin Depth Gauge (3652A, 3652A-3)
5B	01-210 Reference Flat (3652A, 3652A-3)
6	01-201 5/16" (8 mm) Torque End Wrench, set to 8 lbf·in (0.9 N·m)
7	Male to Male Adapter
8	Female to Female Adapter (2 each)

Figure 1-3. Model 3652A K Connector SOLT Calibration Kit (1 of 2)

9	Male to Female Adapter (2 each)
10	23KF50 Female Short
11	23K50 Male Short
12	24KF50 Female Open
13	24K50 Male Open
14	28KF50A Broadband Female Termination, DC to 40 GHz (2 each)
15	28K50A Broadband Male Termination, DC to 40 GHz (2 each)
16	A18311 Connector Thumb Wheel (4 each)
17	Calibration Component Coefficients on USB Memory Device
18	01-204 Universal Adapter Wrench
19	Not Used

Figure 1-3. Model 3652A K Connector SOLT Calibration Kit (2 of 2)

Model 3653A – N Connector Calibration Kit

The 3653A N Connector Calibration Kit contains all the precision components and tools required to calibrate a VNA with error-corrected measurements for test devices with Type N connectors. Components are included for calibrating both male and female test ports. The kit supports calibration with broadband loads.

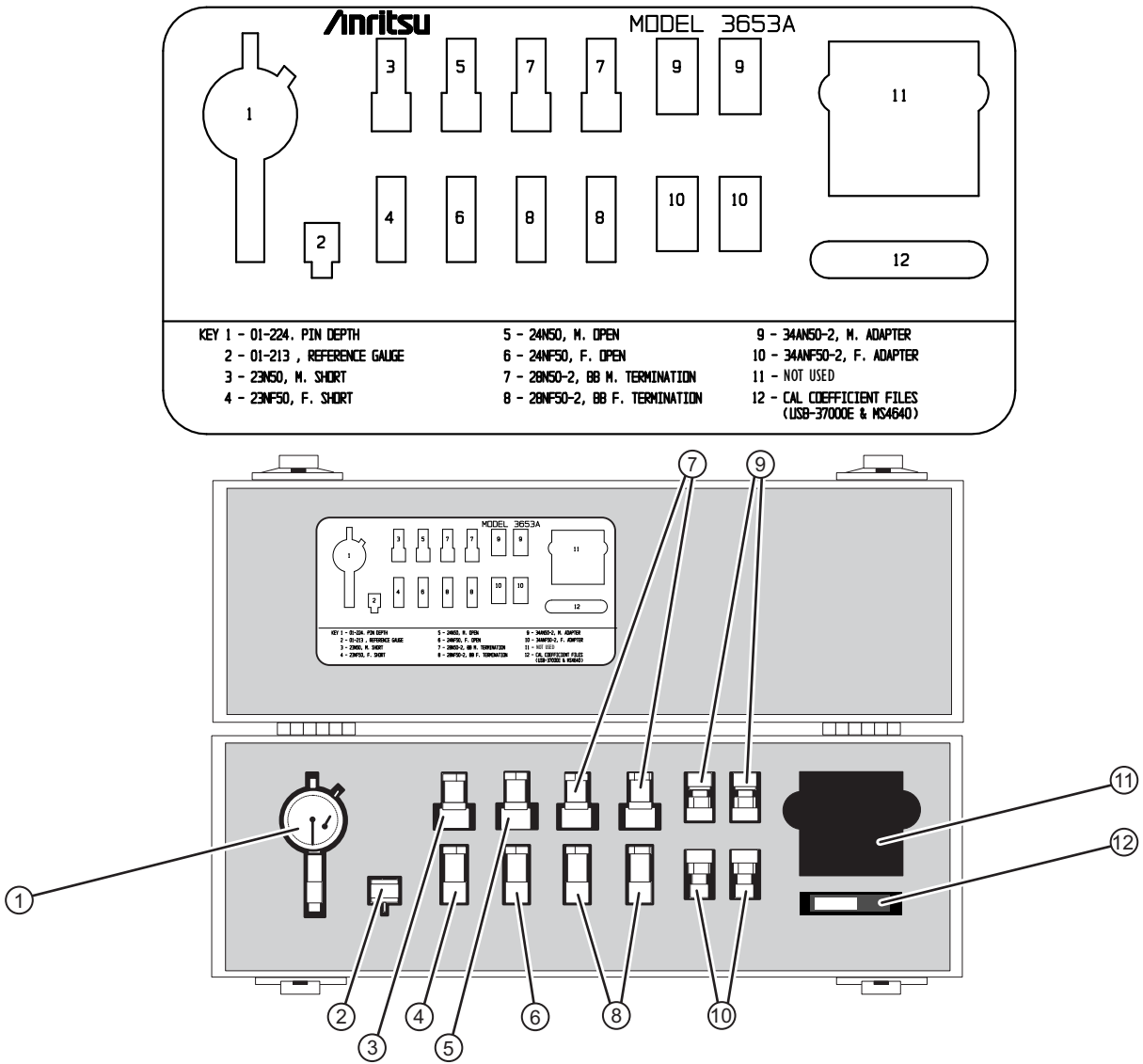

1	01-224 Connector Pin Depth Gauge (for Type N Connectors)
2	01-213 Reference Gauge (for Type N Connectors)
3	23N50 Male Short
4	23NF50 Female Short
5	24N50 Male Open
6	24NF50 Female Open
7	28N50-2 Broadband Male Termination (2 each)
8	28NF50-2 Broadband Female Termination (2 each)
9	34AN50-2 Male Adapter, GPC-7 to N(m) (2 each)

Figure 1-4. Model 3653A N Connector SOLT Calibration Kit (1 of 2)

10	34ANF50-2 Female Adapter, GPC-7 to N(f) (2 each)
11	Not Used
12	Calibration Component Coefficients on USB Memory Device

Figure 1-4. Model 3653A N Connector SOLT Calibration Kit (2 of 2)

Model 3654D / 3654D-x – V Connector Calibration Kit

The 3654D/3654D-x Calibration Kits contain all the precision components and tools required to calibrate a VNA with error-corrected measurements for test devices with V Connectors. Components are included for calibrating both male and female test ports. The kit supports calibration with broadband loads. See [Table 1-1 on page 1-1](#) for additional component option applicability.

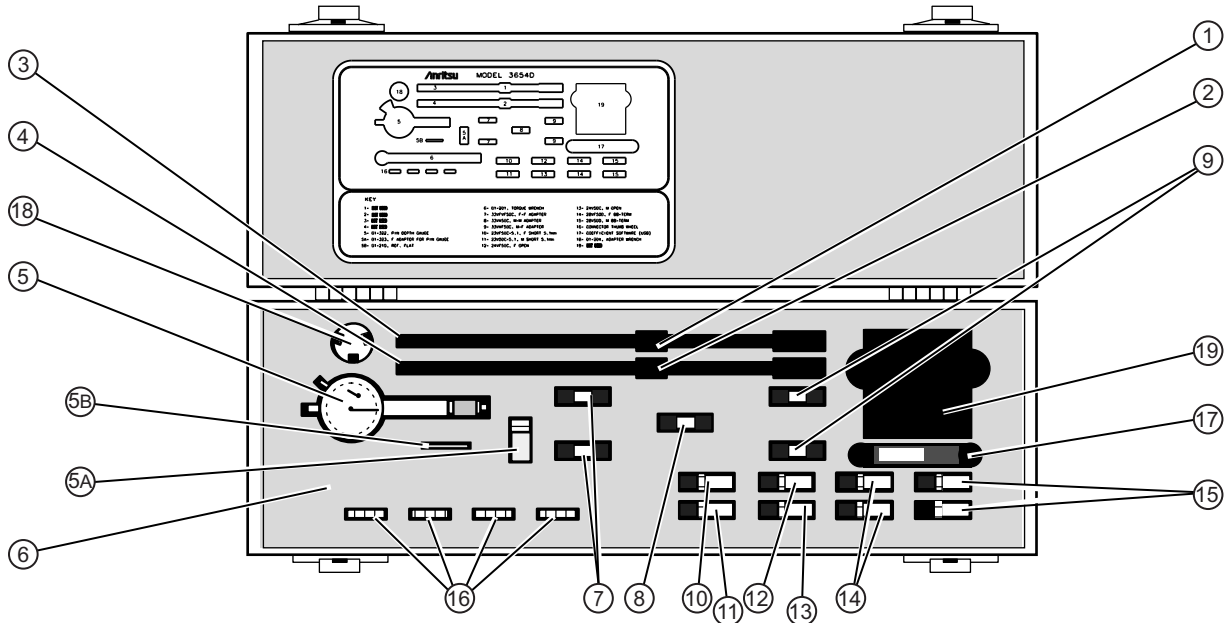
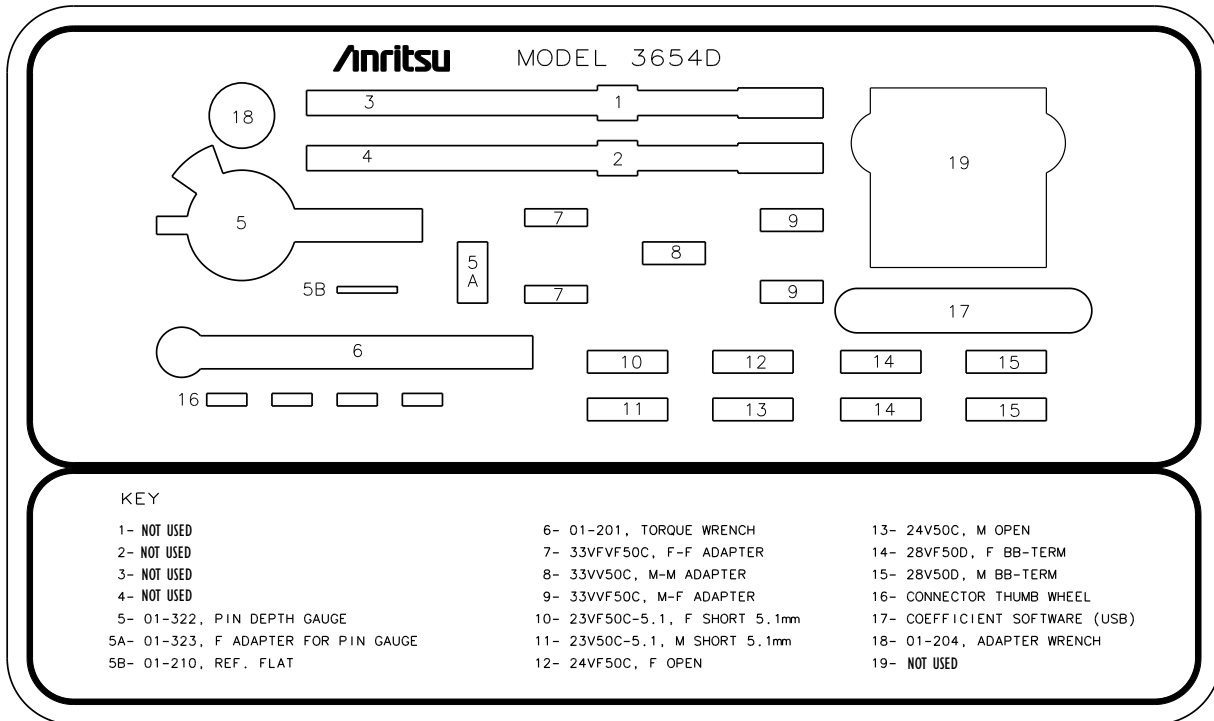

1	Not Used (Sliding Loads no longer available.)
2	Not Used (Sliding Loads no longer available.)
3	Not Used

Figure 1-5. Model 3654D V Connector Calibration Kit Contents (1 of 2)

4	Not Used
5	01-322 Pin Depth Gauge (3654D, 3654D-3 only)
5A	01-323 Female Adapter for Pin Depth Gauge (3654D, 3654D-3 only)
5B	01-210 Reference Flat (3654D, 3654D-3 only)
6	01-201 5/16" (8 mm) Torque End Wrench, set to 8 lbf·in (0.9 N·m)
7	33VVF50C Female to Female Phase Equal Adapter (2 each)
8	33VV50C Male to Male Phase Equal Adapter
9	33VVF50C Male to Female Adapter (2 each)
10	23VF50C-5.1 Female Short (5.1 mm offset)
11	23V50C-5.1 Male Short (5.1 mm offset)
12	24VF50C Female Open
13	24V50C Male Open
14	28VF50D Female Broadband Termination (2 each)
15	28V50D Male Broadband Termination (2 each)
16	A18311 Connector Thumb Wheel (4 each)
17	Calibration Component Coefficients on USB Memory Device
18	01-204 Universal Adapter Wrench (2 each)
19	Not Used

Figure 1-5. Model 3654D V Connector Calibration Kit Contents (2 of 2)

Chapter 2 — Connector Pin Depth Measurement

2-1 Introduction

Pin depth dimensions are critical for the mechanical integrity, non-destructive mating and electrical performance of coaxial RF connectors. Before mating RF connectors, the pin depth of each device should be measured. This chapter provides instructions for properly measuring pin depth using the pin depth gauge provided in each applicable Anritsu calibration kit.

Mechanical gauging of coaxial connectors will detect and prevent the following problems:

Positive Pin Depth

- Positive pin depth or pin protrusion can result in buckling of the fingers of the female center conductor or damage to the internal structure of a device due to the axial forces generated.

Negative Pin Depth

- Excessive negative pin depth or pin recession can result in poor return loss, unreliable connections, and could even cause breakdown under peak power conditions.

A connector should be checked before it is used at a minimum of once per day when in use. If the connector is to be used on another item of equipment, the connector on the equipment to be tested should also be gauged.

Pin depth gauges should be checked for cleanliness before they are used at a minimum of once per month. The connector cleaning procedures in [Chapter 3, “Maintenance Instructions”](#) can be used to clean the pin depth gauges.

Pin Depth Defined

Pin depth is the distance between the outer conductor reference plane and the plane that intersects the shoulder of the male or female center conductor.

- For a female connector, it is the plane that intersects the shoulder (face) of the female center conductor.
- For a male connector, it is the plane that intersects the shoulder of the male center conductor.

The pin depth definition for 3.5mm, K, and V female and male connectors is illustrated in [Figure 2-1](#).

The pin depth definition for Type N female and male connectors is illustrated in [Figure 2-2](#).

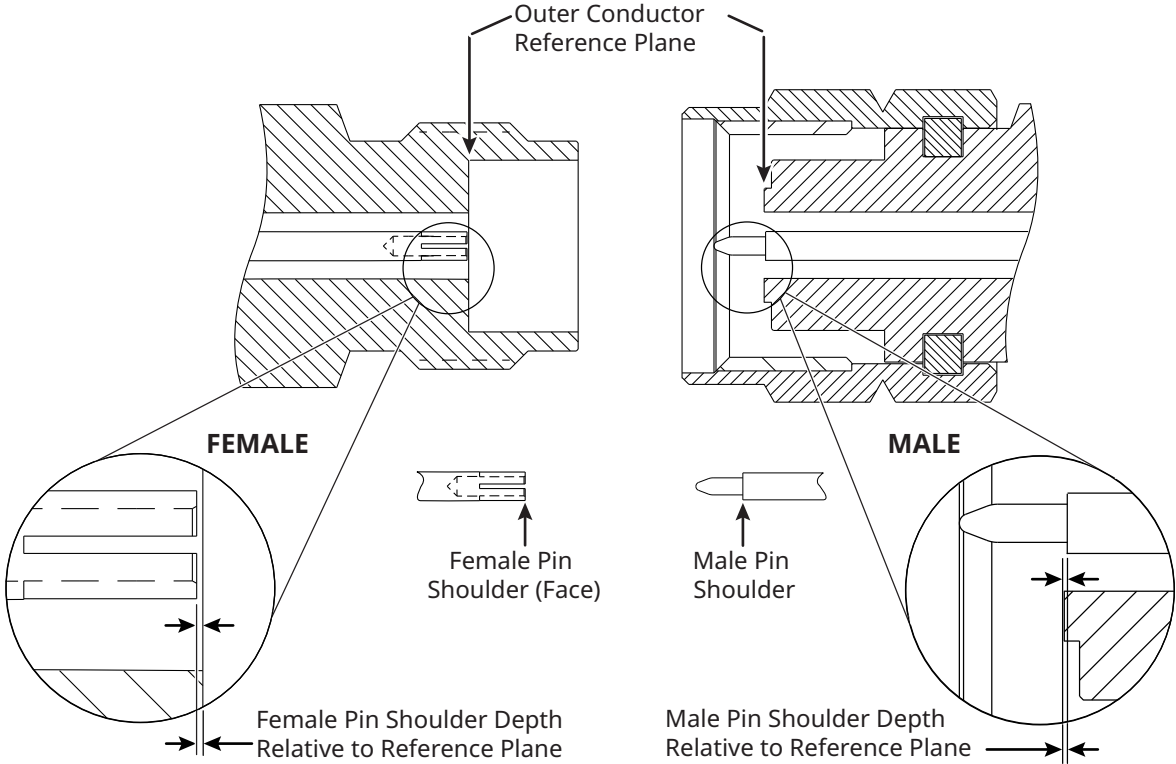

Figure 2-1. 3.5 mm, K, and V Connector Pin Depth Definition

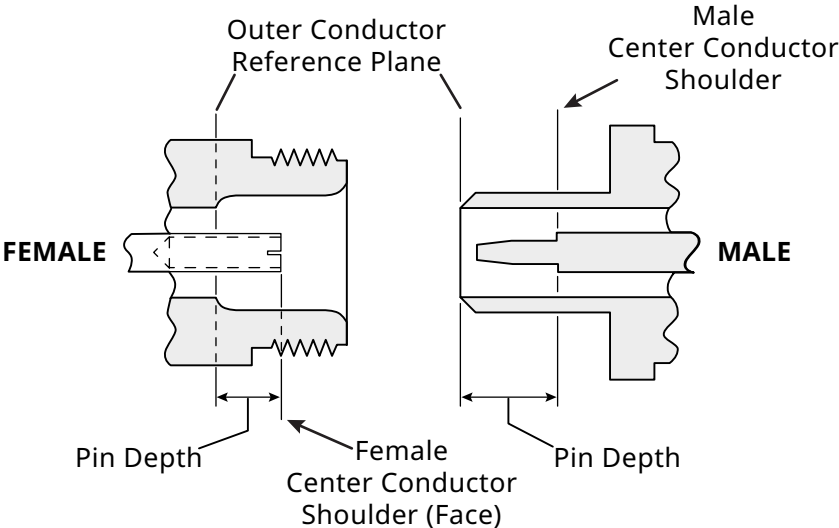

Figure 2-2. Type N Connector Pin Depth Definition

Pin Depth Limits

Pin depth is not a performance specification but it provides an indication of the mechanical condition of the calibration kit components. By verifying whether the pin depth is within the expected range of limits, one can determine if the component is in good mechanical condition. [Table 2-1](#) lists the range of the observable limits of each calibration kit component as shown on the pin depth gauge that is supplied with the calibration kit.

Note	Standards and government committees have created pin depth limits on the most common connectors to ensure the ability of mating with connectors of the same type. Components in the calibration kit might have a narrower acceptable range of pin depth limits due to electrical performance optimization.
	Connectors on devices that mate with connectors of calibration kit components may not have the proper depth. They must be measured before mating to ensure suitability and to avoid connector damage to the components.
	Anritsu Pin Depth Gauge accuracy specification is ± 0.0002 in.

Table 2-1. Pin Depth Limits (1 of 2)

Connector Type/Device Type	Observed Pin Depth Limits (Inches)	
	Male	Female
GPC-7		
Terminations/Loads	-0.0002 to -0.0007 (GPC-7 has no gender)	
Shorts	Not applicable due to design	
Opens	+0.0005 to -0.0010	
Type N		
Note: For Type N connectors, the pin depth gauge (P/N 01-224) is zeroed on the +0.207 or -0.207 inch reference block depending on the gender of the N connector, so the gauge reading is always +0.000 to -0.002 inches for the 34 Series adapter, and +0.000 to -0.001 inches for Loads/Opens/Shorts.		
34 Series Adapter (N to GPC-7)	Type N: -0.207 to -0.209 GPC-7: -0.0002 to -0.0007	Type N: +0.205 to +0.207 GPC-7: -0.0002 to -0.0007
Terminations/Loads	-0.207 to -0.208	+0.206 to +0.207
Shorts	-0.207 to -0.208	+0.206 to +0.207
Opens	-0.207 to -0.208	+0.206 to +0.207
3.5 mm		
33 Series Adapter	-0.0002 to -0.0010	-0.0002 to -0.0010
34 Series Adapter (3.5 mm to GPC-7) ^a	-0.0002 to -0.0007 (3.5 mm and GPC-7)	-0.0002 to -0.0007 (3.5 mm and GPC-7)
Terminations/Loads	-0.0002 to -0.0007	-0.0002 to -0.0007
Shorts	-0.0002 to -0.0007	-0.0002 to -0.0007
Opens	-0.0002 to -0.0007	-0.0002 to -0.0007
K Connector		
33 Series Adapter	-0.0002 to -0.0010	-0.0002 to -0.0010
34 Series Adapter (K to GPC-7)	-0.0002 to -0.0007 (K and GPC-7)	-0.0002 to -0.0007 (K and GPC-7)
Terminations/Loads	-0.0002 to -0.0015	-0.0002 to -0.0015
Shorts	-0.0002 to -0.0007	-0.0002 to -0.0007
Opens	-0.0002 to -0.0007	-0.0002 to -0.0007

Table 2-1. Pin Depth Limits (2 of 2)

Connector Type/Device Type	Observed Pin Depth Limits (Inches)	
	Male	Female
V Connector		
33 Series Adapter	-0.0002 to -0.0010	-0.0002 to -0.0010
Terminations/Loads	-0.0002 to -0.0020	-0.0002 to -0.0020
Shorts	-0.0002 to -0.0010	-0.0002 to -0.0010
Opens	-0.0002 to -0.0010	-0.0002 to -0.0010

a. Starting with kit serial number 1644002, part numbers 34AS50-2 and 34ASF50-2 (3.5 mm to GPC-7 Adapters) are not supplied with the 3650A calibration kits.

Reading Pin Depth

When gauging pin depth, if the connector measures out of tolerance in the “+” region of the gauge, the center pin too long or is protruding. Mating under this condition can damage or break female pin contact fingers. If the test device connector measures out of tolerance in the “-” region, the center pin is too short or is recessed. While this will not cause any damage, it will result in a poor connection and a consequent degradation in performance.

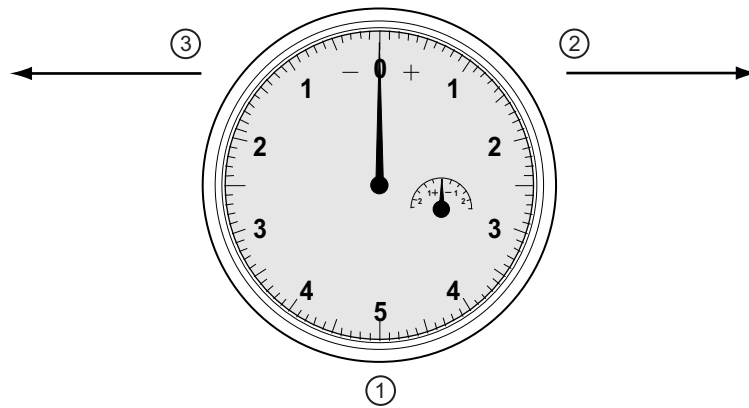

- 1 – Pin Depth Gauge with needle setting at zero.
- 2 – Positive needle direction clockwise to right. Center pin is long or protruding.
- 3 – Negative needle direction counter-clockwise to left. Center pin is short or recessed.

Figure 2-3. Pin Depth Gauge

2-2 Pin Depth Gauging Procedures

Model 3650A – 3.5 mm Connector Pin Depth Measurement

1. On the pin depth gauge, loosen the side lock knob (2).
2. If attached, remove the female adapter (5) from the gauge body coupling nut.
3. Hold the reference block (3) against the end of the gauge body and turn the gauge outer ring until the pointer rests on zero.
4. Tighten the side lock knob.
5. To measure female connectors, unscrew the gauge coupling nut (4) and slide it forward.
6. To measure male connectors, leave the gauge coupling attached to the gauge body. Screw the female adapter (5) to the coupling nut.



1	01-222 Pin-Depth Gauge measures the depth in mils of the male and female center conductors. The gauge reads from 0.001 inch to 0.025 inch (25 mils) in 0.0001 inch increments.
2	Side Lock Knob prevents the gauge face from moving.
3	01-210 Reference Flat provides a smooth surface for setting a zero reference on the pin-depth gauge.
4	Gauge Coupling Nut connects a female connector to the gauge.
5	01-223 Female Adapter attaches the gauge to male connectors.
6	01-223 Female Adapter attaches the gauge to female connectors.

Figure 2-4. 3.5 mm Pin Depth Gauge

Model 3651A – GPC-7 Connector Pin Depth Measurement

1. Turn the gauge coupling nut (2) until the threads are fully retracted.
2. Loosen the side lock knob (3).
3. Hold the reference flat against the end of the gauge connector and turn the outer dial ring until the pointer rests on zero.
4. Tighten the side lock knob.
5. Remove the center conductor contact collet from the connector to be measured using the collet removal tool (item 1 in the kit).
6. Attach the gauge to the connector and read the pin depth.
7. Remove the gauge and replace the center conductor collet.

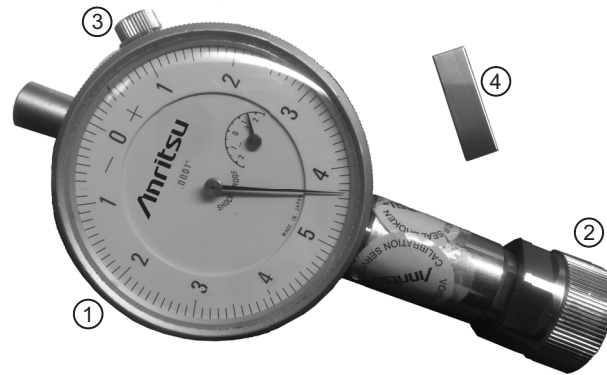

1	01-220 Pin-Depth Gauge measures the depth in mils of the male and female center conductors. The gauge reads from 0.001 inch to 0.015 inch (15 mils) in 0.0001 inch increments.
2	Gauge Coupling Nut attaches the gauge to the connector.
3	Side Lock Knob prevents the gauge face from moving.
4	01-210 Reference Block provides a smooth surface for setting a zero reference on the pin-depth gauge.

Figure 2-5. GPC-7 Pin Depth Gauge

Model 3652A / 3652A-X – K Connector Pin Depth Measurement

1. On the pin depth gauge, loosen the side lock knob (2).
2. If attached, remove the female adapter (5) from the gauge body coupling nut.
3. Hold the reference block (3) against the end of the gauge body and turn the gauge outer ring until the pointer rests on zero.
4. Tighten the side lock knob.
5. To measure female connectors, unscrew the gauge coupling nut (4) and slide it forward.
6. To measure male connectors, leave the gauge coupling attached to the gauge body. Screw the female adapter (5) to the coupling nut.



1	01-222 Pin-Depth Gauge measures the depth in mils of the male and female center conductors. The gauge reads from 0.001 inch to 0.025 inch (25 mils) in 0.0001- inch increments.
2	Side Lock Knob prevents the gauge face from moving.
3	01-210 Reference Block provides a smooth surface for setting a zero reference on the pin-depth gauge.
4	Gauge Coupling Nut connects a female connector to the gauge.
5	Female Adapter attaches the gauge to male connectors.
6	01-223 Female Adapter attaches the gauge to female connectors.

Figure 2-6. K Connector Pin Depth Gauge

Model 3653A – Type N Connector Pin Depth Measurement

1. On the pin depth gauge, loosen the side lock knob (2).
2. Hold the reference gauge (3) against the end of the gauge connector and turn the gauge outer ring until the pointer rests on zero.
3. Tighten the side lock knob.

Note For Type N connectors, the pin depth gauge is zeroed on the +0.207 or –0.207 inch reference block depending on the gender of the N connector, so the gauge reading is always +0.000 to –0.002 inches for the 34 Series adapter, and +0.000 to –0.001 inches for Loads/Opens/Shorts.

4. To measure female N connectors, screw the female adapter (5) onto the end of the gauge body.
5. To measure male N connectors, remove the female adapter.

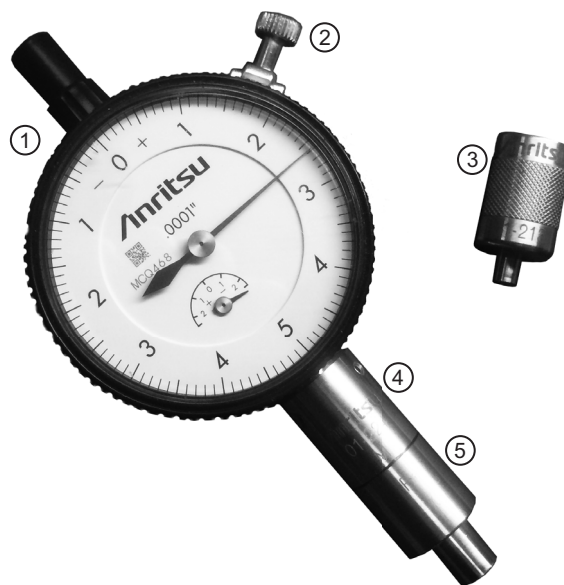

1	01-224 Pin-Depth Gauge measures the depth in mils of the male and female center conductors. The gauge reads from 0.001 inch to 0.025 inch (25 mils) in 0.0001 inch increments.
2	Side Lock Knob prevents the gauge face from moving.
3	01-213 Reference Block provides a smooth surface for setting a zero reference on the pin-depth gauge.
4	Gauge Coupling Nut connects a female connector to the gauge.
5	Female Adapter attaches the gauge to male connectors.

Figure 2-7. Type N Pin Depth Gauge

Model 3654D / 3654D-X – V Connector Pin Depth Measurement

1. On the pin depth gauge, loosen the side lock knob (2).
2. If attached, remove the female adapter (5) from the gauge body coupling nut.
3. Hold the reference gauge (4) against the end of the gauge connector and turn the gauge outer ring until the pointer rests on zero.
4. Tighten the side lock knob.
5. To measure female V connectors, screw the female adapter (5) onto the end of the gauge body.
6. To measure male V connectors, remove the female adapter.

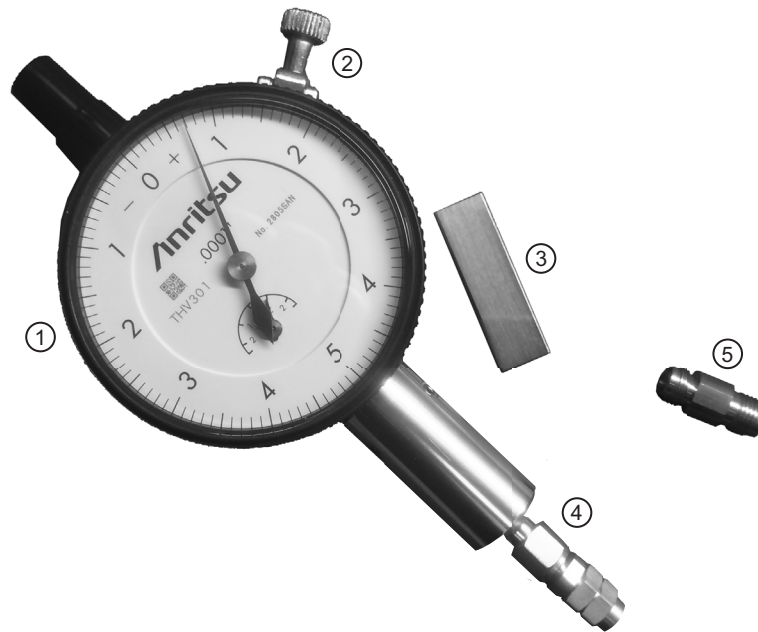

1	01-322 Pin-Depth Gauge measures the depth in mils of the male and female center conductors. The gauge reads from 0.001 inch to 0.025 inch (25 mils) in 0.0001 inch increments.
2	Side Lock Knob prevents the gauge face from moving.
3	01-210 Reference Block provides a smooth surface for setting a zero reference on the pin-depth gauge.
4	Gauge Coupling Nut connects a female connector to the gauge.
5	Female Adapter attaches the gauge to male connectors.

Figure 2-8. V Connector Pin Depth Gauge

Chapter 3 — Maintenance Instructions

3-1 Introduction

This chapter provides instructions for the maintenance and proper connection and torquing of the RF connectors on your Anritsu instrument, and components you connect to the instrument, including the calibration kit components described in this manual. Following the recommendations in this document prevents shortened connector life and less equipment downtime due to connector-related failures. The topics covered in this chapter are:

- Inspection and cleaning
- Connection techniques
- Torque specifications and tools

Note	The components in these kits are of the highest quality and accuracy. All components are NMI (National Metrology Institute) and NIST (National Institute of Standards and Technology) traceable. Mechanical shock can damage them. Handle with care.
-------------	--

Common Causes of Connector Failure

Following are common causes of connector-related instrument failures and effects on measurement accuracy and repeatability.

- Connectors contaminated with material such as metal debris and dust particles will increase the risk of damaging connector. A dusty connector affects the measurement accuracy due to lack of repeatability.
- Worn or damaged threads can damage mating connectors.
- Over torquing connectors will introduce excessive stress to connector interface. Under torquing will increase repeatability uncertainty.
- Improper pin depth of the center conductor can permanently damage the mating connector.

Coaxial Connector Care

Most coax connectors are assembled into a system and forgotten, but some, especially on test equipment are used almost continuously. The care and cleaning of these connectors is critical to maintain accurate and reliable performance. Good connector performance can be achieved with the following:

- Periodic visual inspection
- Routine cleaning
- Proper connection and disconnection techniques using a torque wrench
- Appropriate gauging techniques

3-2 Visual Inspection

Connectors contaminated with material such as metal debris and dust particles will increase the risk of damaging the connector. A dusty connector affects the measurement accuracy due to lack of repeatability. Careful visual inspection with a magnification aid and lighting should be performed at least once per day before connecting. A “good” connector may get damaged if it is mated with a “bad” one.

Any connector with the following defects should be repaired or discarded:

- Plating concerns that include bubbles, blisters, and deep scratches showing bare metal on the mating plane.
- Center conductors with bent, broken or damaged contacts.

Magnification

Use a device with a magnification range of 2X to 10X.

Connector Type	Minimum Magnification for Inspection
Type N 3.5 mm	2X
K (2.92 mm) V (1.85 mm)	7X

Figure 3-1. Magnification for Connector Inspection

Outer Conductor and Thread Inspection

When connector threads are clean and free from defects, coupling nuts should move freely. Inspect for defects such as:

- Dirt, dust, metal particles and oil
- Damaged threads (distorted, dented, or crushed)
- Dents or raised edges on the mating plane

Note

Connectors may lose some gloss over time due to normal usage. Light scratches, marks, and other cosmetic imperfections found on the mating plane surfaces are signs of normal wear and should not be considered cause for replacement.

Regular cleaning and proper connection techniques will minimize wear on the plating due to abrasion from debris.

Center Conductor Inspection

Inspect for bent, broken, or damaged center conductors:

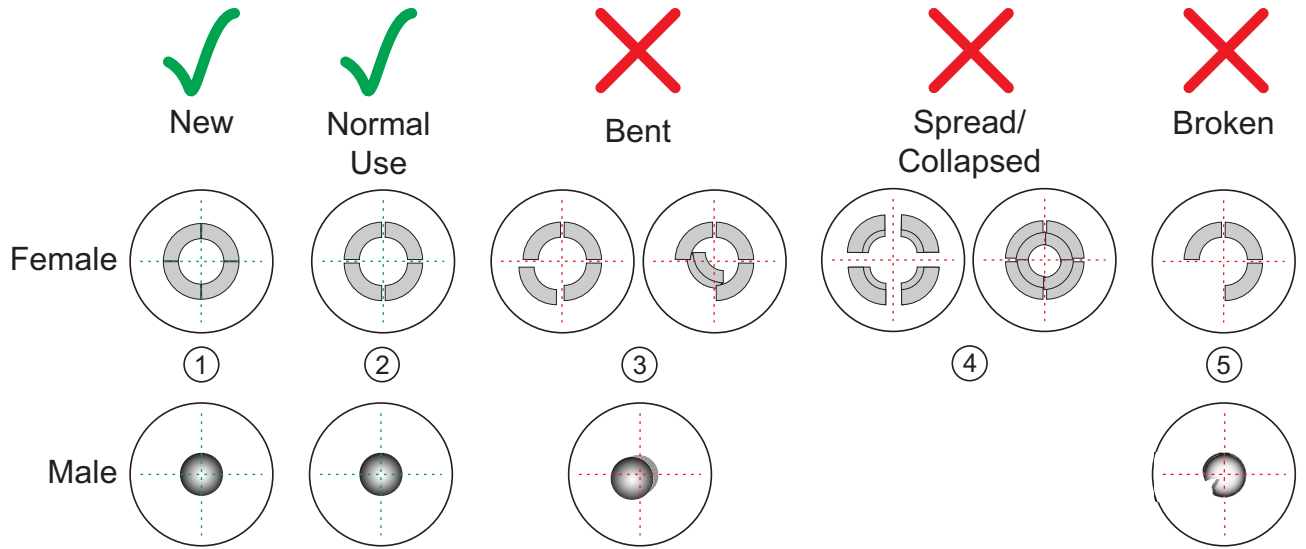

Index	Description
1	New condition
2	Normal use – Slight gap
3	Bent pin section - Discard connector
4	Fingers spread or collapsed - Discard connector
5	Broken pin or pin section - Discard connector

Figure 3-2. Example Connector Damage States

Inspect for center pin concentricity:

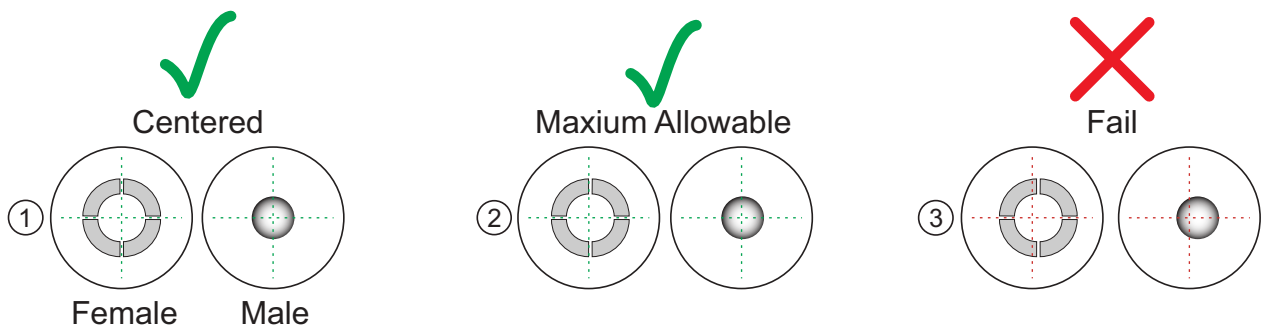

Index	Description
1	Centered
2	Maximum allowable off-center
3	Fail - off center - Discard connector

Figure 3-3. Example Connector Concentricity

3-3 Connector Cleaning

With repeated connections and disconnections, the threads and outer conductor mating interface builds up a layer of dirt and metal chips which can severely degrade connector electrical and mechanical performance. This debris can also increase the coupling torque required for a good connection which can then damage the mating interfaces. Cleaning of connectors is essential for maintaining good electrical performance. Therefore, connectors should be checked for cleanliness before making any measurements (or calibration).

Caution Use the correct sized cotton swabs that are made specifically for cleaning small areas. Oversized cotton swabs can put lateral pressure on the center pin and damage it. Inspect after cleaning to be sure that no cotton strands get caught in the connector.

Required Cleaning Items

- Low-pressure dry, compressed air (oil free, solvent free), maximum pressure: 40 PSI
- Lint-free cotton swabs
- Isopropyl alcohol (IPA), >90 %
- Microscope Cleaning Procedure

Teflon Tuning Washers: The center conductor on some RF components contains a small teflon tuning washer located near the point of mating (interface). This washer compensates for minor impedance discontinuities at the interface. The washer's location is critical to the RF component's performance. Be careful not to disturb it with a cotton swab or compressed air and don't apply alcohol to it.

Caution Compressed Air: Do not use compressed air on power sensors. Some power sensors have components internally located near the connector that can be damaged from excessive air pressure.

Solvents: Do not use industrial solvents or water to clean the connector. Use 90 % Isopropyl Alcohol (IPA) only. Do not spray alcohol directly onto connector surfaces. Do not saturate the swab with alcohol. Instead, lightly dampen it by touching the tip onto a bead of alcohol formed at the bottle tip as shown in [Figure 3-4](#).

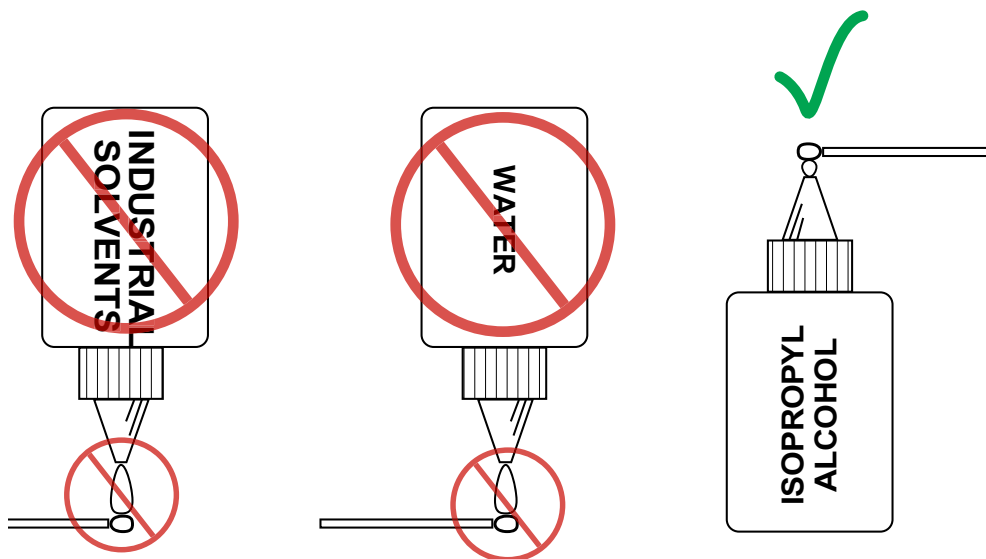

Figure 3-4. Isopropyl Alcohol Only

Procedure

1. Remove loose particles on the mating surfaces, threads, and similar surfaces using low-pressure clean (oil free, solvent free) compressed air (40 PSI max) applied at a shallow angle so foreign particles are not forced down into the connector.

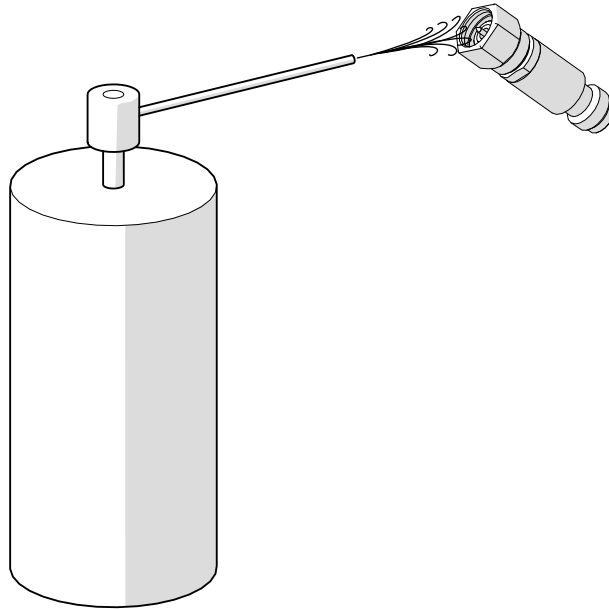

Figure 3-5. Low Pressure Compressed Air Cleaning

2. Clean the threads of the connector with a lint-free cotton swab dampened with IPA.

Caution Do not insert cotton swabs at an angle or use a swab that is too large (Figure 3-6). Doing so can damage the center pin.



Figure 3-6. Avoid Angled or Large Swab

3. Clean the mating surfaces and connector threads by gently moving the cotton swab around the center pin. Avoid applying pressure to the center pin.

When the connector is clean, you should be able to hand tighten the connector to within approximately one half turn of the specified torque.

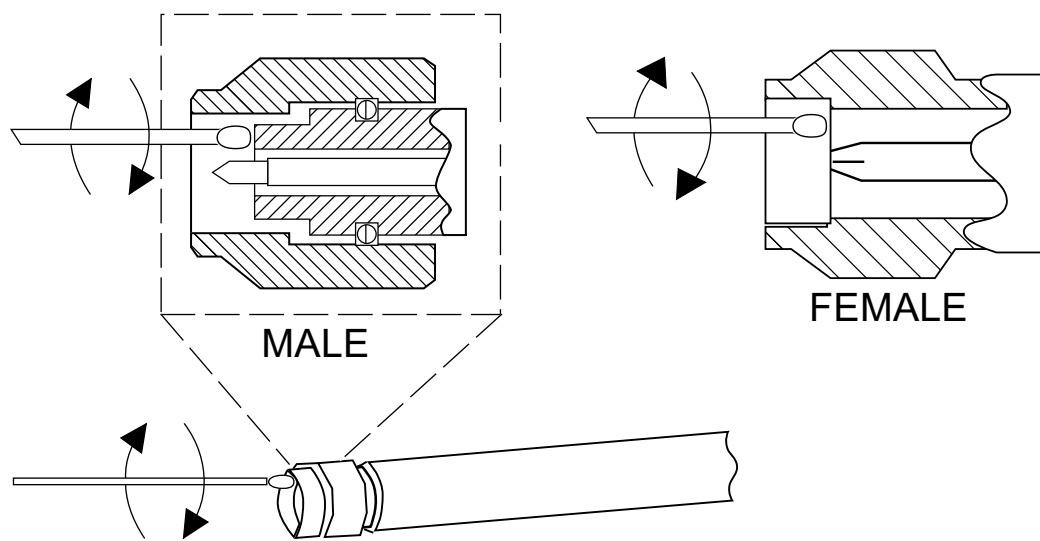

Figure 3-7. Cleaning Connector with Cotton Swabs

4. After cleaning with swabs, again use low-pressure compressed air to remove any remaining small particles and dry the connector surfaces.
5. Using magnification and adequate lighting, inspect the connectors for damage or debris.

3-4 Making a Connection

This section provides connection and torquing instructions for making a repeatable connection and avoiding damage to the connector.

Caution	Connectors should never be forced together when making a connection since forcing often indicates incorrectness and incompatibility.
	Use a torque wrench with the correct setting to tighten the connector. Over torquing connectors may damage the connector center pin.
	Never use pliers or adjustable wrenches to tighten connectors.

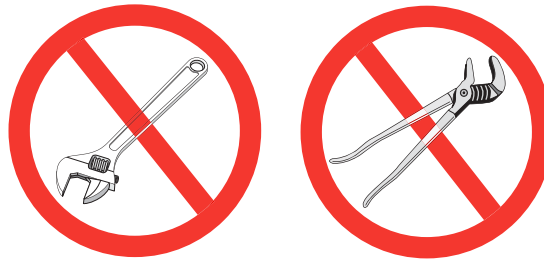

Figure 3-8. Do Not Use Pliers or Adjustable Wrenches

Before Connection

1. Verify the power and voltage levels of the device you are connecting to and the input limits of your test equipment.
2. Visually inspect the connectors for damage, cleanliness, and center pin concentricity as described in [Section 3-2](#)
The coupling nut should move freely. If necessary, clean the connectors
3. Before touching instrument connectors, make sure you have grounded yourself and eliminated all static charge by following proper ESD handling procedures that conform to ANSI/ESD S20.20-2007.

Initial Connection

1. Carefully align the connectors as shown in [Figure 3-9 on page 3-8](#).
The male connector center pin must slip concentrically into the contact fingers of the female connector. Never apply excessive force when making a connection.
2. Push the connectors straight together.
3. Do not twist while pushing them together and do not turn the connector body. As the center conductors mate, there is usually a slight resistance. Finger-tighten the connection first by turning the connector nut.
4. Back off the connection by turning the connector nut counter clockwise 1/4 turn. The final tightening is done using the appropriate torque wrench from the kit and as described in [Table 3-1](#)

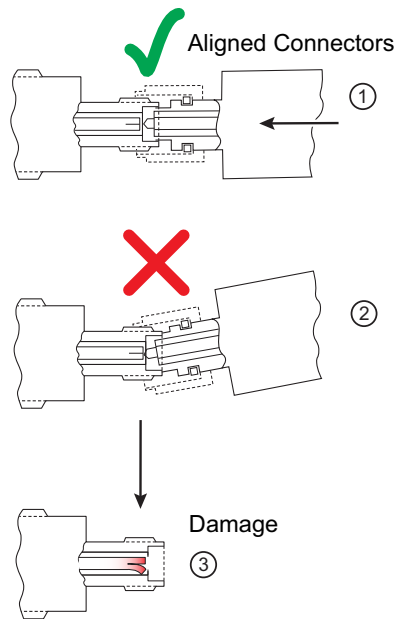

Index	Description
1	Aligned connectors
2	Misalignment can cause pin damage
3	Damaged pin

Figure 3-9. Avoid Pin Damage Due to Misalignment

Caution Do not turn the connector body. Major damage to the center conductor and the outer conductor can occur if the connector body is twisted.

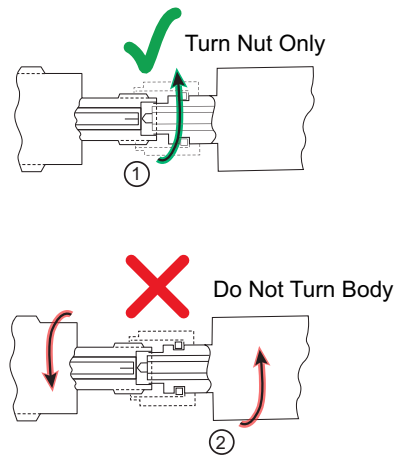

Index	Description
1	Turn nut only
2	Do not turn body

Figure 3-10. Tightening the Connector Nut

Torquing the Connection

Connectors must be correctly torqued to their required settings to make sure the connector is tight enough to ensure an accurate RF measurement but not so tight as to damage the connector or the instrument. Use the correct torque wrench for the connector type. Applying proper torque will improve connection repeatability and reproducibility. Over torquing connectors is destructive as it may damage the connector center pin. Never use pliers to tighten connectors.

1. Select a torque wrench of proper size and rating for the connector and an open end wrench. The open end wrench is used to prevent the body of the connector from turning. Refer to [Table 3-1](#) for torque specifications.
2. Place the two wrenches at an angle of less than 90° as shown in [Figure 3-11](#).

Caution

Using two wrenches with an angle greater than 90° causes the devices to lift up, which tends to misalign and stress the connectors. This becomes more of a problem when multiple devices are connected together.

Breaking the handle fully can cause the wrench to kick back which may loosen the connection.

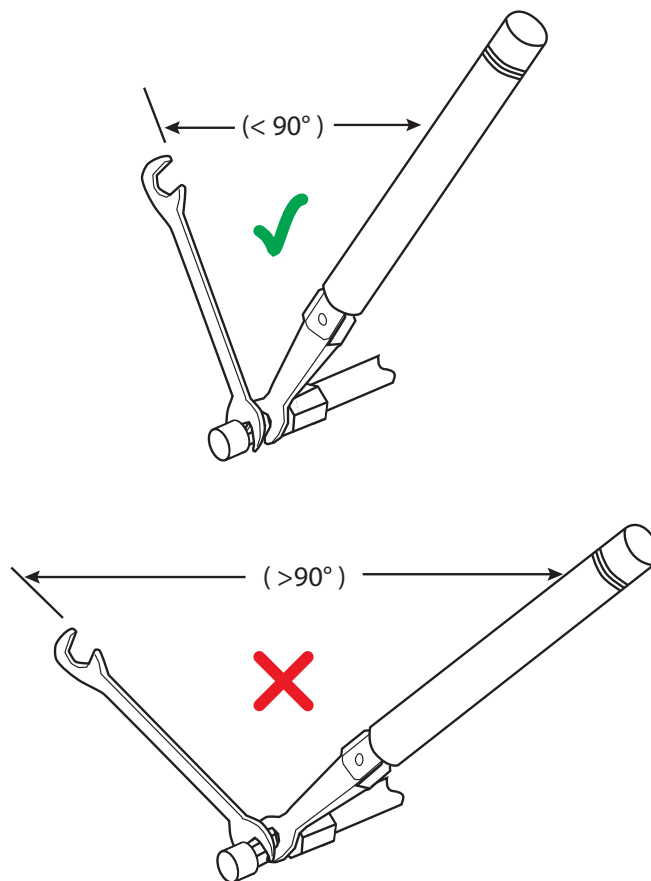
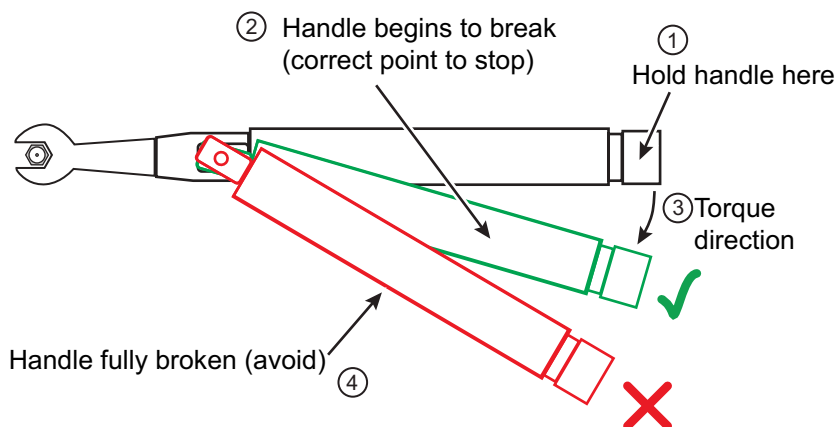

Figure 3-11. Using Wrenches at Proper Angle

3. Hold the torque wrench at the end as shown in [Figure 3-12 on page 3-10](#).

Caution

Holding the torque wrench anywhere but at the end applies an unknown amount of torque and can damage contacts and/or connectors.



Index	Description
1	Hold handle here
2	Handle begins to break - Stop torquing
3	Torque direction
4	Handle fully broken - Avoid torquing this far

Figure 3-12. Using a Torque Wrench

- Before torquing, make sure long or heavy devices or cables are supported so there is no lateral pressure on the connection
- Rotate *only* the connector nut when tightening the connection. Apply torque to the fitting until the handle begins to break as shown in [Figure 3-12](#).

Torque Specifications and Tools

Torque values are listed below for connectors used with the 365xx-x mechanical calibration kits. If you are not sure which connector types are available on your instrument, consult the instrument Technical Data Sheet available on the web at www.anritsu.com.

Table 3-1. Connector Torque Settings and Recommended Tools

Connector Type/Size	Wrench Size	Torque Setting	Recommended Tools
3.5 mm ^{a b}	8 mm 5/16 in	0.9 N·m 8 lbf·in	01-201 5/16 in Torque End Wrench 01-204 5/16 in or 8 mm Open End Wrench
GPC-7	19 mm 3/4 in	12 lbf·in 1.36 N·m	01-200 3/4 in Torque End Wrench
K (2.92 mm)	8 mm 5/16 in	0.9 N·m 8 lbf·in	01-201 5/16 in. Torque End Wrench 01-204 5/16 in. or 8 mm Open End Wrench
V (1.85 mm)	8 mm 5/16 in	0.9 N·m 8 lbf·in	01-201 5/16 in. Torque End Wrench 01-204 5/16 in. or 8 mm Open End Wrench

a. 3.5 mm, 2.92 mm and K connectors are electrically compatible with 3.5 mm and have the same connector nut size (8 mm) and torque requirement. Refer to [Table 3-2](#) for connector compatibility information.

b. Although the 2.4 mm, 1.85 mm, and V connectors have the same connector nut size (8 mm) and torque requirement, they are not mechanically compatible with 3.5 mm. Refer to [Table 3-2](#) for connector compatibility information.

Disconnection

To properly separate an RF connection:

1. Use the same wrench usage technique as shown in [Figure 3-11](#).
2. Use one to prevent the connector body from turning. Use the other to loosen the connector nut.
3. Complete the disconnection by hand, turning *only* the connector nut.
4. Pull the connectors straight apart without twisting or bending.

Connector Types and Cross-Mating Compatibility

The following table lists RF connector characteristics and cross-mating compatibilities.

Table 3-2. RF Connector Characteristics

Connector Type/ Parameter	7/16 DIN	20 GHz Type N	Type N	7 mm	SMA	3.5 mm	K (2.92 mm)	2.4 mm	V (1.85 mm)	W1 (1 mm)	0.8 mm
Upper Frequency Limit (GHz)	7.5	20	18	18	18	26.5	40	50	70	110	145
Mating Type	M/F	M/F	M/F	Sexless	M/F	M/F	M/F	M/F	M/F	M/F	M/F
Cross-mating Compatibility	7/16 DIN only	Type N	20 GHz Type N	7 mm only	3.5 mm, K	K, SMA	3.5 mm, SMA	V	2.4 mm	W1 (1 mm) only	0.8 mm only
Dielectric	Air	Air	Air	Air	Teflon	Air	Air	Air	Air	Air	Air
Thread	M29 x 1.5	5/8–24	5/8–24	0.6785-24	1/4–36	1/4–36	1/4–36	M7 x 0.75	M7 x 0.75	M4 x 0.7	M3.5 x 0.35
Outer Conductor (mm)	16	7	7	7	4.2	3.5	2.92	2.4	1.85	1	0.8

Anritsu



Anritsu utilizes recycled paper and environmentally conscious inks and toner.

Anritsu Company
490 Jarvis Drive
Morgan Hill, CA 95037-2809
USA
<http://www.anritsu.com>