

# ORTEC®

## *ICS™* *Integrated Cryocooling System*

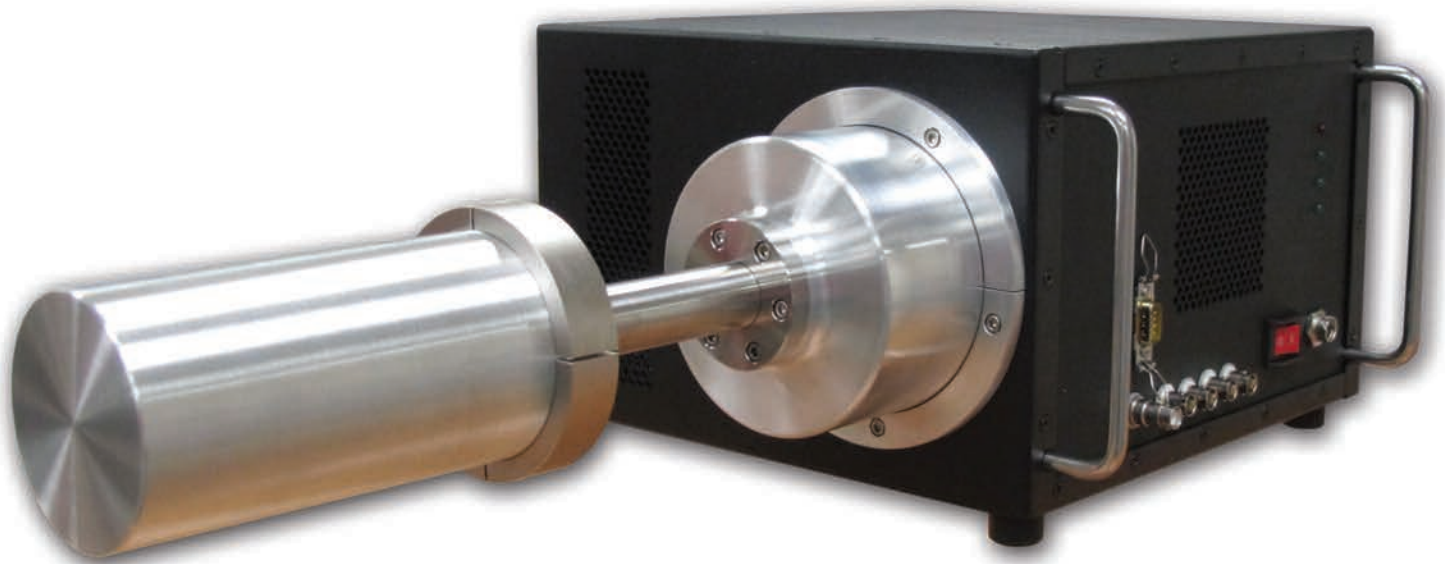

ORTEC's most advanced Integrated Cryocooling System offers premium detector resolution and LN<sub>2</sub>-free operation, for excellence in performance, safety, reliability and value.

**AMETEK®**  
ADVANCED MEASUREMENT TECHNOLOGY

# ICS™ Integrated Cryocooling System

ICS™ — The newest integrated electro-mechanical cooling system for HPGe radiation detectors from ORTEC exploits the latest generation in cryogenic technology to provide LN<sub>2</sub> free operation with no loss of detector performance. Incorporating a unique **hardened cryostat**, ICS delivers enhanced benefits for users desiring state-of-the-art electro-mechanical cooling solutions.

ICS is a highly reliable, maintenance free, electro-mechanically cooled cryostat delivering superior performance for HPGe radiation detectors. Using a Sunpower<sup>1</sup> industry proven Stirling cooler, ICS is more efficient and reliable than pulse tube designs. Increased efficiency means improved cooling with proportionally less heat generation and lower power consumption. With a cooler Mean-Time-To-Failure (MTTF) of **over 200,000 hours**, ICS operational reliability is unmatched.

ICS incorporates AVC™ (Active Vibration Cancellation) technology, and is designed to **virtually eliminate vibrational and audible noise** levels. This provides resolution performance comparable to LN<sub>2</sub> cooled systems in all operational orientations, and making it **the choice** for customers seeking premium resolution and versatility in a vast array of HPGe applications.

ICS is designed with a **vacuum hardened cryostat**. This feature eliminates the need to fully thermal cycle the detector in the event of a partial warm-up, a common deficiency in other types of electro-mechanical or LN<sub>2</sub> cryostats. Additionally, ICS does not require the use of gas filters or lines used in older generation Joule-Thomson or Klemenko cycle coolers — eliminating their associated maintenance issues. As a result, ICS delivers significant improvements in operational up time and maintenance free ease-of-use.

Simplicity in Concept and Simplicity in Use – ICS delivers **superior performance in a compact footprint that reduces weight** and eliminates the need for an external control box present in other, more cumbersome electro-mechanical cooling systems. ICS supports high resolution spectrometry with LN<sub>2</sub> free operation for legacy system upgrades as well as new HPGe radiation detector systems.



<sup>1</sup>Sunpower is a part of AMETEK Advanced Measurement Technology (AMT), a division of AMETEK's Electronic Instruments Group (EIG).

# ICS™ Integrated Cryocooling System

Benefit	Feature
<b>Performance</b> <ul style="list-style-type: none"> <li>• Resolution</li> <li>• Versatility</li> <li>• Environmental Friendly</li> </ul>	<ul style="list-style-type: none"> <li>• Supports all ORTEC GEM detectors. Consult the factory for compatibility with GMX and Profile detectors.</li> <li>• LN<sub>2</sub> free operation with LN<sub>2</sub> equivalent resolution</li> <li>• AVC™ technology</li> <li>• Vibration dampeners</li> <li>• Multi-orientation operation</li> <li>• Wide operating temperature range (-10°C to 40°C)</li> <li>• Quiet, less than 60 dB (A) at 1 meter below 30°C ambient</li> </ul>
<b>Safety</b>	<ul style="list-style-type: none"> <li>• LN<sub>2</sub> free operation</li> <li>• High Voltage Shutdown</li> </ul>
<b>Reliability</b>	<ul style="list-style-type: none"> <li>• Full 2-year warranty on the cryocooler</li> <li>• Long service life, MTTF &gt; 200,000 hours cooler</li> </ul>
<b>Cost Effective</b> <ul style="list-style-type: none"> <li>• Low Cost of Ownership</li> <li>• Availability</li> <li>• Compatibility</li> </ul>	<ul style="list-style-type: none"> <li>• LN<sub>2</sub> free operation</li> <li>• Low power consumption (Sunpower cooler)</li> <li>• Long service life, MTTF &gt; 200,000 hours cooler</li> <li>• No maintenance (no gas lines or filters)</li> <li>• Vacuum hardened cryostat (no molecular sieve, no need for thermal cycling)</li> <li>• Small footprint and light weight (integrated controller, no external box)</li> <li>• Select the cooling rod length at the time of the order. Lengths are available from 2 - 12 inches (51 - 305 mm) in .5 inch increments.</li> </ul>

## Spectroscopic Performance

When purchasing a new ORTEC detector with an ICS, resolution performance is based on the specifications in the detector configuration guide for your selected detector type. ICS cool down time depends on the detector size and starting temperature. For example, typical cool down time for a 60% relative efficiency coaxial detector from room temperature is approximately six hours.

Return to the factory is required when upgrading an existing LN<sub>2</sub> or electro-mechanical system, ORTEC or other, to an ICS. Performance of an upgraded detector is warranted to be within 10% of the combined resolution and efficiency of the HPGe detector at the time of the upgrade determined at the factory before reconfiguration. An example of combined relative efficiency and resolution is a 5% increase in resolution and a 5% decrease in relative efficiency, or a 10% increase in resolution and 0% decrease in relative efficiency.

# ICS™ Integrated Cryocooling System

## Typical Applications

- **Commercial, Government and Environmental Labs** – The ICS is a superb choice due to no compromise of resolution performance and low audible noise. There is no requirement for refilling the LN<sub>2</sub> on a regular basis, providing increased cost savings, detector availability, and minimizing work hazard.
- **Nuclear Power and Industrial Plants** – The ICS provides an advantage in deployments where power failures are frequent. The hardened cryostat increases detector availability by eliminating the need for thermal cycling and reduces equipment down time. With no need for regular maintenance and LN<sub>2</sub> filling, personnel spend less time in radiation “hot” zones. The compact size of the ICS allows easy installation into new or existing counting setups.
- **Research Facilities/Universities** – Similar to Lab applications, the ICS is an excellent choice due to no compromise of resolution performance and low audible noise. No need for LN<sub>2</sub> gives the ICS a low cost of ownership.
- **Waste Management** – Hardened cryostat specification makes the ICS an excellent choice for applications requiring maximum “up time”.
- **Health Physics** – Low heat generation, low audible noise and no compromise on resolution performance give the ICS an edge for HPGe systems in the field of health physics, whether as an upgrade or as a new HPGe system.
- **Field Remediation, Mobile or Remote Monitoring** – The ICS is an unmatched solution in these applications due to a combination of unique features: the hardened cryostat which eliminates the need to fully thermal cycle the detector in the event of a partial warm-up, low power consumption and the use of a universal power supply.

## Major Market Benefits

Key Attribute	Commercial, Government and Environmental Labs	Nuclear Power and Industrial Plants	Research Facilities/ Universities	Waste Management	Health Physics	Field Remediation, Mobile or Remote Monitoring
LN <sub>2</sub> Free	✓	✓	✓	✓	✓	✓
High Resolution	✓		✓		✓	
Quiet Operation	✓		✓		✓	
Compact Size		✓		✓	✓	✓
Hardened Cryostat		✓		✓		✓
Low Power Consumption					✓	✓
Wide Operating Temperature		✓		✓		✓
All Attitude Operation		✓		✓	✓	✓

# ICS™ Integrated Cryocooling System

## Specifications

HPGe Compatibility	All ORTEC GEM detectors. Consult factory for compatibility with GMX, Profile or other manufacturer's detectors.
Resolution	New ORTEC detectors: Warranted equivalent to LN <sub>2</sub> with cooler running at room temperature (see detector configuration guide for specifications).
Cooler	AMETEK Sunpower with AVC™ (active vibration cancelation) technology.
All-Attitude Operation	Yes
Hardened Cryostat	Yes
Molecular Sieve	No
Compatible Endcap Windows	Aluminum, Carbon Fiber, Beryllium.
Weight	40 lbs (18 kg) excluding the detector.
Environmental	Temperature range: -10°C to 40°C. Humidity: non-condensing.
Typical Power Consumption	70 W typical, 130 W maximum.
Electrical Supply	100-240 V AC (50/60 Hz) auto ranging.
Status Display	4 LED lights indicate status: power ON/OFF, COLD, cooler On/OFF, preamp count rate.
Connectors	4 each BNC (energy out, energy or timing out, HV Shutdown, test). 1 each SHV cable (high voltage in). 1 each 9 pin (preamp power). Note: 1) additional BNC is added for TRP preamp (-PL) option. 2) HV Shutdown out is converted to Temperature Readout in the SMART option.
Remote Preamp	Yes
PopTop® Compatible	No
Low-Background Option	Yes
Audible Noise	Less than 60 dB (A) at 1 meter fully operational, below 30°C ambient.
Auxiliary Cooling	Internal fan (vented).
Backup Battery	No built-in battery. ICS is compatible with commercial batteries and universal power supplies (UPS). ORTEC offers an optional UPS.
Cooler Life	>200,000 hours.
Warranty	2 years on cryocooler, internal controller and active noise cancelation. 1 year on detector and preamplifier.
Maintenance	Easily removable, washable inlet air filter. No other maintenance is required.
Stand Compatibility	Stand not included. Optional stand (ICS-STAND) is available.

# ICS™ Integrated Cryocooling System

## Dimensions

- Dimensions listed in mm [inches] are for reference only and subject to change.
- If dimensional constraints are critical, contact the factory.

Endcap Model [dia. mm]			-70	-76	-83	-95	-108	
% Efficiencies available in this endcap size			0-35	25-45	25-65	60-110	120-150	
Dim.	Unit	Tol.						
A	mm (in)	0.3 (0.01)	70 (2.75)	76 (3.0)	83 (3.25)	95 (3.75)	108 (4.25)	
BB	mm (in)	0.3 (0.01)	85 (3.4)	92 (3.6)	98 (3.9)	111 (4.4)	124 (4.9)	
CC	mm (in)	5 (0.2)	145 (5.7)	158 (6.2)	158 (6.2)	158 (6.2)	183 (7.2)	
LL	mm (in)	3 (0.1)	Choose from 51, 64, 76, 89, 102, 114, 127, 140, 152, 165, 178, 191, 203, 216, 229, 241, 254, 267, 279, 292, or 305					
NOTE: [102 mm [4 in.] is typical length]								

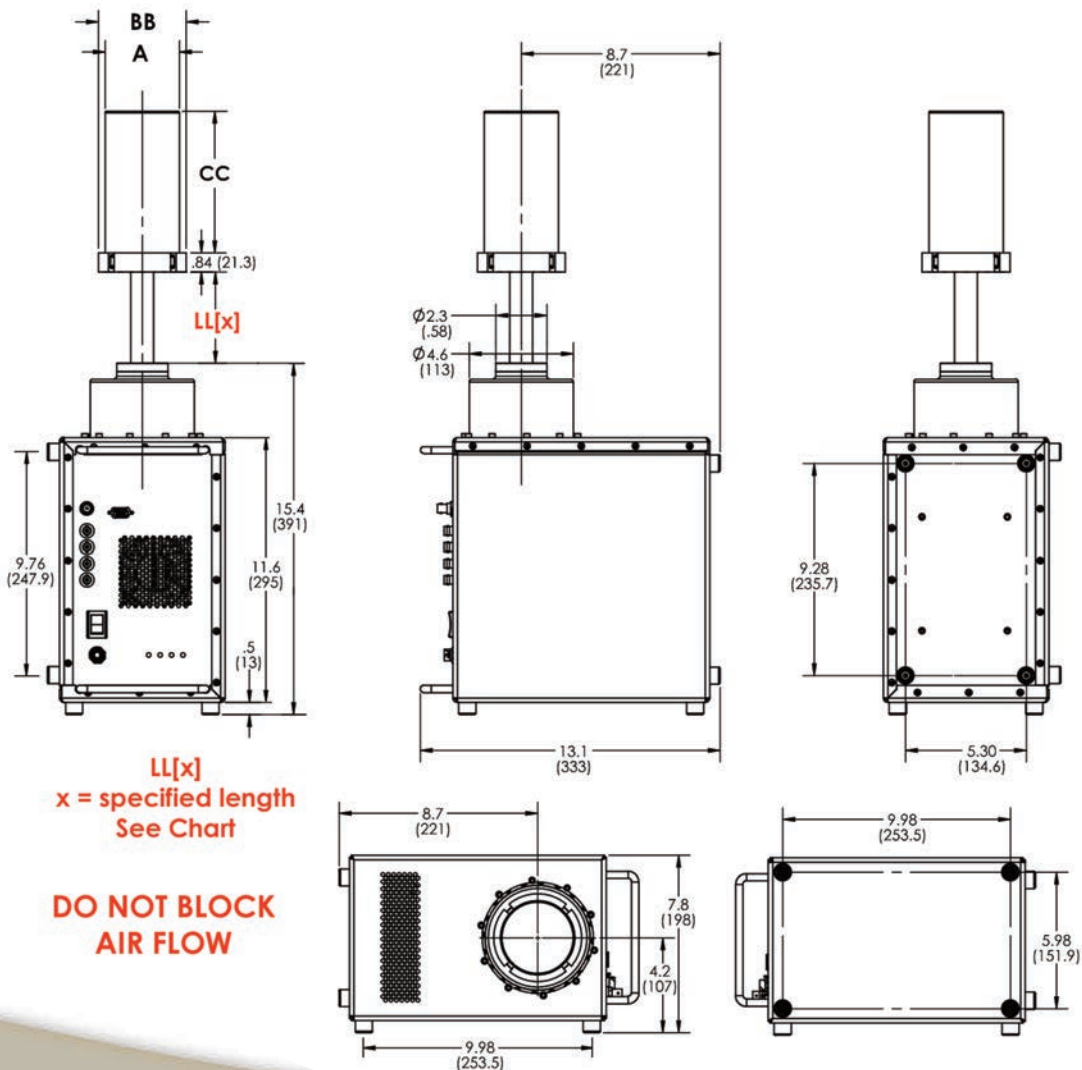

# ICS™ Integrated Cryocooling System

## Accessories

The ICS-STAND is intended for single user installation of the ICS. It incorporates a multi-positional height selector to set overall operating height, and uses a pneumatic arm to raise and lower the ICS. This variable height selection accommodates most commercial shield tables. Rollers on the stand provide easy positioning of the ICS underneath the shields. Note, the ICS-STAND is for vertical orientation only.

Caution: Since the ICS must be installed into a shield from below, the user must ensure the shield opening is greater than the detector seal-clamp diameter. (Dimension BB.)

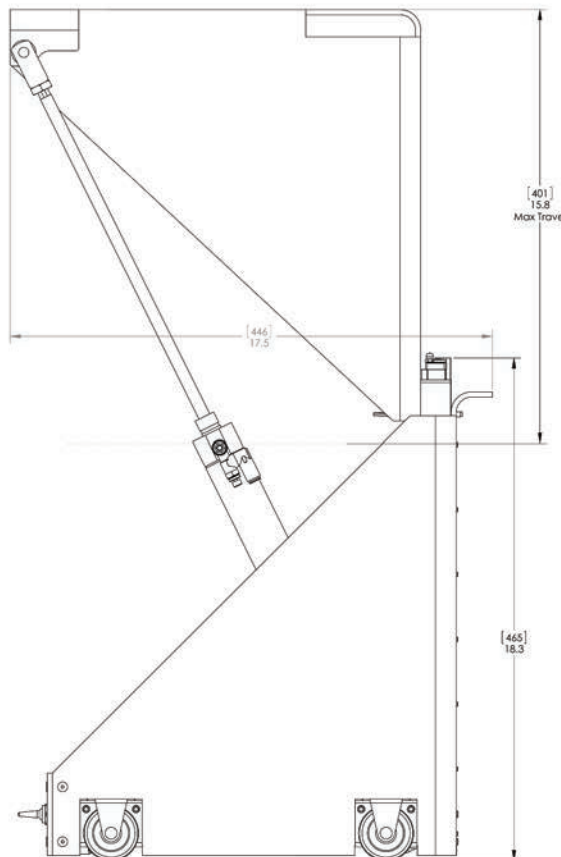
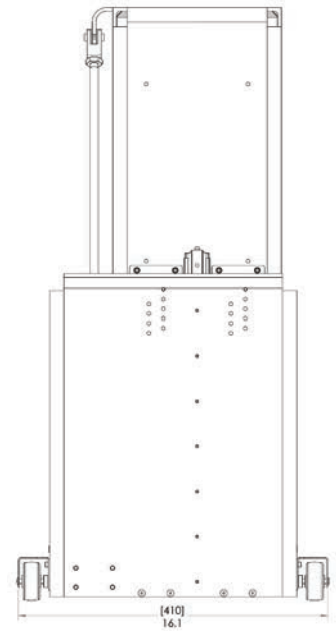
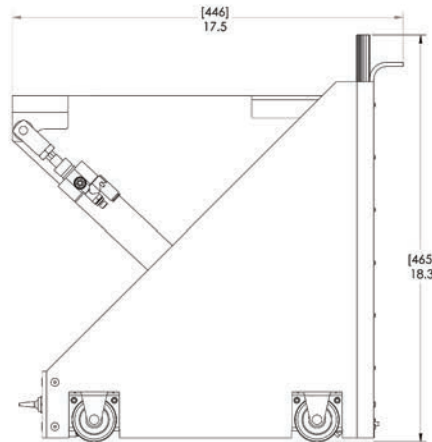



# **ICS™ Integrated Cryocooling System**

## **Ordering Information**

See the GEM detector configuration guide.

Consult the factory for ordering GMX and PROFILE detectors.

Specifications subject to change  
091014

**ORTEC®**

**[www.ortec-online.com](http://www.ortec-online.com)**

Tel. (865) 482-4411 • Fax (865) 483-0396 • [ortec.info@ametek.com](mailto:ortec.info@ametek.com)  
801 South Illinois Ave., Oak Ridge, TN 37830 U.S.A.  
For International Office Locations, Visit Our Website

**AMETEK®**  
ADVANCED MEASUREMENT TECHNOLOGY