

# Stokes 6" Series Mechanical Booster Pumps



Edwards Stokes Vacuum 6" Mechanical Booster Pumps



The 1 11/16 inch extra large shaft diameter engineered into the Stokes 6" series provides the capability for use with higher powered motors, in addition to ensuring a uniquely rugged and durable mechanical booster. The use of higher powered motors in conjunction with the high differential specification, allows the pumps to operate at their full displacement from atmospheric pressure, with appropriately sized backing pumps the 612MB offers these advantages in a standard package.

The Stokes 6" series is also available in a process isolation series (five mechanical seals) for optimum protection from dust and particulate contamination in arduous duty applications.

All mechanical vacuum boosters must be backed by a primary vacuum pump designed to discharge to atmospheric pressure. Below is a list of commonly used backing pumps:

- Oil Sealed Pumps (EM or EV)
- Liquid Ring Pump (Two-stage LR Series)
- Piston Pumps (Stokes Microvac Series)
- Dry Pump (GV Drystar or Chemical Drystar)

## Features & Benefits

- Mechanical shaft seal - improved life and serviceability
- Ringfeder® keyless gear locking system - stronger, faster timing
- Large shaft diameters - allowing improved performance at high pressures
- Belt drive or direct drive capability - flexibility of operating speeds and motor power
- Vertical or horizontal gas flow - flexibility of orientation
- Drive end roller bearing - resists belt pull and thermal effects
- Over-sized anti-friction bearings - increased uptime and longer service intervals
- Rugged proven design and construction
- Air Cooled - utility savings
- Unique impeller design -Dynamically balanced to minimise vibration
- High volumetric efficiency - optimal performance
- High differential pressure - operation capability
- Available by-pass option for improved pumpdown
- Available process isolation seal option-optimum protection from dust and particulate contamination

## Applications

Typical applications for the Stokes 6" series mechanical booster pumps includes:

- Automotive
- Chemical processing
- Heat treatment
- Leak detection
- Metallurgy
- PET processing
- Pharmaceuticals
- Thermal processing
- Transformer drying and cable fluid conditioning
- Vacuum coating
- Vacuum melting
- Many other industrial applications

Stokes 6" series mechanical boosters are available in sizes 1020-6630 m<sup>3</sup>h<sup>-1</sup> / 612-3900 ft<sup>3</sup>min<sup>-1</sup>. Features include:

- Rugged design for reliable and extended operation
- Simple maintenance features incorporated in design
- Vertical or horizontal gas flow
- Options of direct drive motors or bare shaft machines
- Options of by pass technology to reduce pump down time and process isolation seals
- Dynamically balanced impellers

### Overview

Used in conjunction with rotary-piston, rotary vane, dry vacuum and liquid ring pumps, Stokes 6" series will increase pumping speed at working pressures and shorten pump down time significantly. Whether your objective is to reduce valuable time from the front end of your pumping cycle, or to substantially boost pumping capacity for high out-gassing applications, the result is the same - significantly reduced cycle times.

Stokes 6" series are compatible with any make or type of vacuum pumping system. The boosters can be mounted separately, or on the inlet of the backing pump. The latter forms a compact integrated package as a mechanical booster system. For even lower-pressure applications, two Stokes 6" series can be used in series with one backing pump. This results in a significantly lower-cost and space-saving pumping system.

Bypass technology is available in the 615 model to enhance your productivity further, while also assuring consistent, reproducible vacuum processing. The bypass valve limits the maximum differential pressure, enabling the booster to start from atmosphere and provide increased pumping capacity over the full pressure range. Eliminating the electrical pressure switch insures continuous, booster operation regardless of vacuum level.



# Stokes 607 Series Process Isolation Boosters



Stokes 6" series mechanical boosters are designed to be used in conjunction with rotary-piston, dry vacuum, rotary vane and liquid ring pumps to increase pumping speed at working pressures and shorten pump down time significantly. They incorporate five mechanical seals for optimum protection from dust and particulate contamination and can be mounted separately or on the inlet of the backing pump to create a compact integrated package.

Featuring an extra large diameter shaft, the Stokes 6" series has the capability for use with higher powered motors in addition to ensuring a uniquely rugged and durable mechanical booster.

## Features & Benefits

- Mechanical shaft seal – improved life and serviceability
- Ringfeder® keyless gear locking system – stronger, faster timing
- Large shaft diameters – allowing improved performance at high pressures
- Belt drive or direct drive capability
- Vertical or horizontal gas flow

## Technical Data

Displacement	
V belt (2750 rpm)	1589m <sup>3</sup> h <sup>-1</sup> / 935ft <sup>3</sup> min <sup>-1</sup>
Direct drive (3000 rpm)	1733m <sup>3</sup> h <sup>-1</sup> / 1020ft <sup>3</sup> min <sup>-1</sup>
Direct drive (3600 rpm)	2080m <sup>3</sup> h <sup>-1</sup> / 1224ft <sup>3</sup> min <sup>-1</sup>
Inlet/outlet flanges	6" ASA/ANSI flange
Motor power E /Asia	7.5kW
Motor power S TEFC	10hp
Cooling water	7.6-11.4l min <sup>-1</sup> / 2-3gal min <sup>-1</sup>
Oil capacity (horizontal flow)	1.9 litre / 0.51gal
Oil capacity (vertical flow)	4. litre / 1.1gal
Max pressure differential	506 mbar / 380 Torr
Max temp rise	135°C / 275°F
Max discharge temp	191°C / 375°F
Weight bare shaft	215kg / 475lbs
Weight TEFC direct drive	345kg / 760lbs

## Dimensions

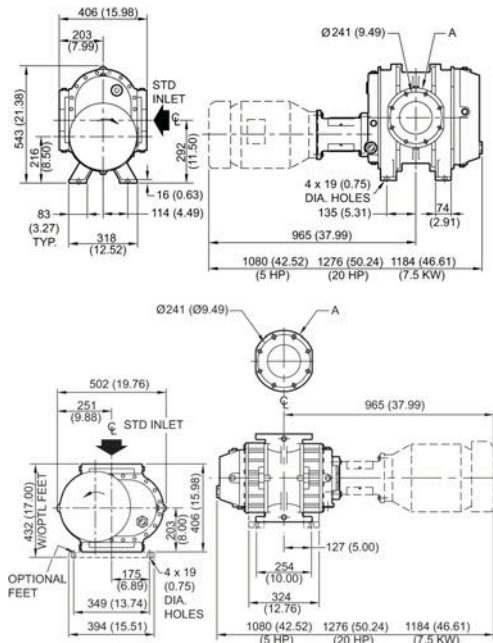

Standard dimensions: A - pipe flange connection 11" (279mm) OD x 6" (152mm) ID. 8 x 3/4-10 NC-2B x 1 1/8" (29mm) holes straddle both CL flanges

## Ordering Information

Product description	Order no.
607 5HR CE 7.5kW, 230/400V, 3-ph, 50Hz @ 3000rpm	9006075HR601
607 5HR CE 7.5kW, 200-220/380V, 3-ph, 50/60Hz @ 3000/3600rpm	9006075HR602
607 5H10, 10hp, 230/460V, 3-ph, 60Hz @1800rpm	9006075H10
607 5HR (Bare shaft) Horizontal flow	9006075HR101
607 5V10, 10hp, 230/460V, 3-ph, 60Hz @ 1800rpm	9006075V10
607 5VR (Bare shaft) Vertical flow	9006075VR101
607 5VR CE 7.5kW, 230/400V, 3-ph, 50Hz @ 3000rpm	9006075VR601
607 5VR CE 7.5kW, 200-220/380V, 3-ph, 50/60Hz @ 3000/3600rpm	9006075VR602
Accessories Spares	Order no.
Replacement 6" booster Mseal - seal kit	607552001
Replacement 6" booster - maintenance kit	607552002
Process isolation seal kit	607552004



# Stokes 615 Series Mechanical Booster Pumps

Stokes 6" series mechanical boosters are designed to be used in conjunction with rotary-piston, dry vacuum, rotary vane and liquid ring pumps to increase pumping speed at working pressures and shorten pump down time significantly. The Stokes 6" series can be mounted separately or on the inlet of the backing pump to create a compact integrated package.

Featuring an extra large diameter shaft, the Stokes 6" series has the capability for use with higher powered motors in addition to ensuring a uniquely rugged and durable mechanical booster. This allows the pumps to operate at their full displacement from atmospheric pressure with an appropriately sized backing pump.



## Features & Benefits

- Mechanical shaft seal – improved life and serviceability
- Ringfeder® keyless gear locking system – stronger, faster timing
- Large shaft diameters – allowing improved performance at high pressures
- Belt drive or direct drive capability
- Vertical or horizontal gas flow

## Technical Data

Displacement	
V belt (2750 rpm)	3375m <sup>3</sup> h <sup>-1</sup> / 2000ft <sup>3</sup> min <sup>-1</sup>
Direct drive (1800 rpm)	2210m <sup>3</sup> h <sup>-1</sup> / 1300ft <sup>3</sup> min <sup>-1</sup>
Direct drive (3000 rpm)	3685m <sup>3</sup> h <sup>-1</sup> / 2170ft <sup>3</sup> min <sup>-1</sup>
Direct drive (3600 rpm)	4420m <sup>3</sup> h <sup>-1</sup> / 2600ft <sup>3</sup> min <sup>-1</sup>
Inlet/outlet flanges	8" ASA/ANSI flange
Motor power E /Asia	11kW
Motor power S TEFC	10hp
Cooling method	Air cooled
Oil capacity (horizontal flow)	1.9liter / 0.51gal
Oil capacity (vertical flow)	4.1liter / 1.1gal
Max pressure differential	506mbar / 380Torr
Max temp rise	135°C / 275°F
Max discharge temp	191°C / 375°F
Weight bare shaft	234kg / 515 lbs
Weight TEFC direct drive	390kg / 860lbs

## Dimensions

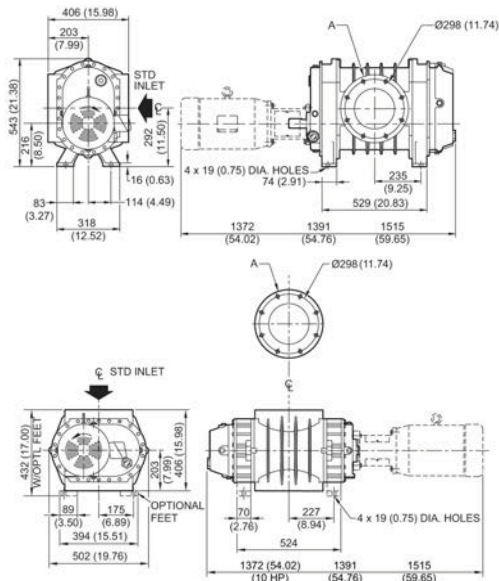

\* pipe flange connection 13 1/2" (3.3 mm) OD x (203 mm) D x 3/4" (-10 C-2B x 1 1/4" (29 mm) holes straddle both CL both flanges

## Ordering Information

Product description	Order no.
615 MHR CE 11kW, 400V, 3-ph, 50Hz @ 3000rpm	900615MHR601
615 MHR CE 11kW, 200-220/380V, 3-ph, 50/60Hz @ 3000/3600rpm	900615MHR602
615 MV10, 10hp, 230/460V, 3-ph, 60Hz @ 1800rpm	900615MV10
615 MV15, 15hp, 230/460V, 3-ph, 60Hz @ 3600rpm	900615MV15
615 MVR (Bare shaft) Vertical flow	900615MVR101
615 MVR CE 11kW, 400V, 3-ph, 50Hz @ 3000rpm	900615MVR601
615 MVR CE 11kW, 200-220/380V, 3-ph, 50/60Hz @ 3000/3600rpm	900615MVR602
615 MH10, 10hp, 230/460V, 3-ph, 60Hz @ 1800rpm	900-615-MH10
615 MH15, 15hp, 230/460V, 3-ph, 60Hz @ 3600rpm	900615MH15
615 MHR (Bare shaft) Horizontal flow	900615MHR101
Accessories Spares	Order no.
Replacement 6" booster Mseal - seal kit	607552001
Replacement 6" booster - maintenance kit	607552002

# Stokes 615 Series Process Isolation Boosters



Stokes 6" series process isolation boosters are designed to be used in conjunction with rotary-piston, dry vacuum, rotary vane and liquid ring pumps to increase pumping speed at working pressures and shorten pump down time significantly. They incorporate five mechanical seals for optimum protection from dust and particulate contamination, and can be mounted separately or on the inlet of the backing pump to create a compact integrated package.

Featuring an extra large diameter shaft, the Stokes 6" series has the capability for use with higher powered motors in addition to ensuring a uniquely rugged and durable mechanical booster. This allows the pumps to operate at their full displacement from atmospheric pressure with an appropriately sized backing pump.

## Features & Benefits

- Mechanical shaft seal – improved life and serviceability
- Ringfeder® keyless gear locking system – stronger, faster timing
- Large shaft diameters – allowing improved performance at high pressures
- Belt drive or direct drive capability
- Vertical or horizontal gas flow

## Technical Data

Displacement	
V belt (2750 rpm)	3375m <sup>3</sup> h <sup>-1</sup> / 2000ft <sup>3</sup> min <sup>-1</sup>
Direct drive (3000 rpm)	3685m <sup>3</sup> h <sup>-1</sup> / 2170ft <sup>3</sup> min <sup>-1</sup>
Direct drive (3600 rpm)	4420m <sup>3</sup> h <sup>-1</sup> / 2600ft <sup>3</sup> min <sup>-1</sup>
Inlet/outlet flanges	8" ASA/ANSI flange
Motor power E /Asia	11kW
Motor power S TEFC	15hp
Cooling water	7.6-11.4 l min <sup>-1</sup> / 2-3 gal min <sup>-1</sup>
Oil capacity (horizontal flow)	1.9 litre / 0.51gal
Oil capacity (vertical flow)	4.1 litre / 1.1gal
Max pressure differential	506mbar / 380Torr
Max temp rise	135°C / 275°F
Max discharge temp	191°C / 375°F
Weight bare shaft	234kg / 515lbs
Weight TEFC direct drive	397kg / 875lbs

## Dimensions

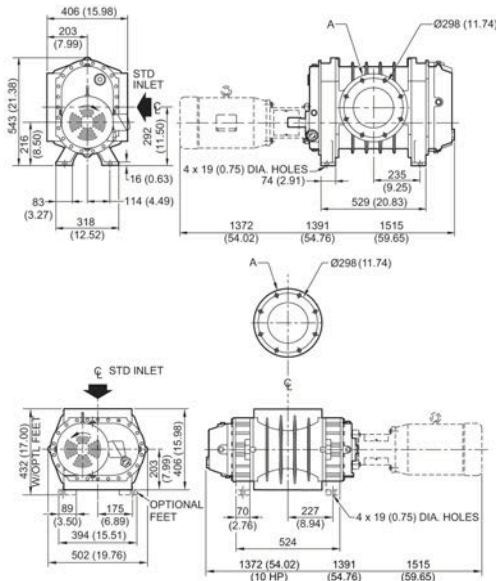

8" pipe flange connection 13 1/2" (343 mm) OD x 8" (203 mm) ID 8 x 3/4-10 NC-2B x 1 1/8" (29 mm) holes straddle both CL both flanges

## Ordering Information

Product description	Order no.
615 5HR CE 11kW, 230/400V, 3-ph, 50Hz @ 3000rpm	9006155HR601
615 5HR CE 11kW, 200-220/380V, 3-ph, 50/60Hz @ 3000/3600rpm	9006155HR602
615 5H15, 15hp, 230/460V, 3-ph, 60Hz @ 3600rpm	9006155H15
615 5HR (Bare shaft) Horizontal flow	9006155HR101
615 5V15, 15hp, 230/460V, 3-ph, 60Hz @ 3600rpm	9006155V15
615 5VR (Bare Shaft) Vertical flow	9006155VR101
615 5VR CE 11kW, 230/400V, 3-ph, 50Hz @ 3000rpm	9006155VR601
615 5VR CE 11kW, 200-220/380V, 3-ph, 50/60Hz @ 3000/3600rpm	9006155VR602
Accessories Spares	Order no.
Replacement 6" booster Mseal - seal kit	607552001
Replacement 6" booster - maintenance kit	607552002
Process isolation seal kit	607552004

# Stokes 61 Series Pass Mechanical Booster Pumps

Stokes 61B by-pass mechanical boosters are designed to be used in conjunction with rotary-piston, dry vacuum, rotary vane and liquid ring pumps to increase pumping speed at working pressures and shorten pump down time significantly. The Stokes 61B by-pass boosters include an integral by-pass valve enabling the booster to start from atmosphere, eliminating the need for a vacuum pressure switch and ensures continuous operation regardless of vacuum level. The Stokes 61B can be mounted separately or on the inlet of the backing pump to create a compact integrated package.



## Features & Benefits

- Mechanical shaft seal – improved life and serviceability
- Ringfeder® keyless gear locking system – stronger, faster timing
- Large shaft diameters – allowing improved performance at high pressures
- Belt drive or direct drive capability
- Vertical or horizontal gas flow

## Technical Data

Displacement	
V belt (2750 rpm)	3375m <sup>3</sup> h <sup>-1</sup> / 2000ft <sup>3</sup> min <sup>-1</sup>
Direct drive (1800 rpm)	2210m <sup>3</sup> h <sup>-1</sup> / 1300ft <sup>3</sup> min <sup>-1</sup>
Direct drive (3000 rpm)	3685m <sup>3</sup> h <sup>-1</sup> / 2170ft <sup>3</sup> min <sup>-1</sup>
Direct drive (3600 rpm)	4420m <sup>3</sup> h <sup>-1</sup> / 2600ft <sup>3</sup> min <sup>-1</sup>
Inlet/outlet flanges	8" ASA/ANSI flange
Motor power E /Asia	18.5kW
Motor power S TEFC	10/25hp
By-pass available	Yes
Cooling method	Air cooled
Oil capacity (horizontal flow)	1.9 litre / 0.51gal
Oil capacity (vertical flow)	4.1 litre / 1.1gal
Max temp rise	135°C / 275°F
Max discharge temp	191°C / 375°F
Weight bare shaft	284kg / 625lbs
Weight TEFC direct drive	530kg / 1170lbs

## Dimensions

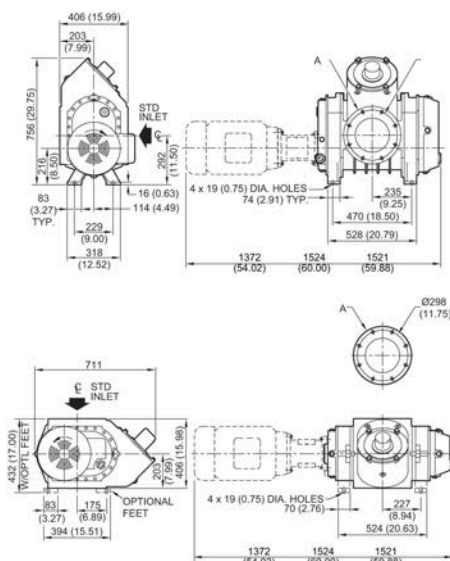

8" pipe flange connection 13 1/2" (343 mm) OD x 8" (203 mm) ID 8 x 3/4-10 NC-2B x 1 1/8" (29 mm) holes straddle both CL both flanges

## Ordering Information

Product description	Order no.
61B MHR CE, 18.5kW, 400V, 3-ph, 50Hz @ 3000rpm	90061BMHR601
61B MHR CE, 18.5kW, 200-220/380V, 3-ph, 50/60Hz @ 3000/3600rpm	90061BMHR602
61B MH10, 10hp, 230/460V, 3-ph, 60Hz @ 1800rpm	90061BMH10
61B MH25, 25hp, 230/460V, 3-ph, 60Hz @ 3600rpm	90061BMH25
61B MHR (Bare shaft) Horizontal flow	90061BMHR101
61B MV10, 10hp, 230/460V, 3-ph, 60Hz @ 1800rpm	90061BMV10
61B MV25, 25hp, 230/460V, 3-ph, 60Hz @ 3600rpm	90061BMV25
61B MVR (bare shaft) Vertical flow	90061BMVR101
61B MVR CE, 18.5kW, 400V, 3-ph, 50Hz @ 3000rpm	90061BMVR601
61B MVR CE, 18.5kW, 200-220/380V, 3-ph, 50/60Hz @ 3000/3600rpm	90061BMVR602
Accessories Spares	Order no.
Replacement 6" booster Mseal - seal kit	607552001
Replacement 6" booster - maintenance kit	607552002

# Stokes 61 Series Process Isolation Boosters



Stokes 61B series process isolation boosters are designed to be used in conjunction with rotary-piston, dry vacuum, rotary vane and liquid ring pumps to increase pumping speed at working pressures and shorten pump down time significantly. It incorporates five mechanical seals for optimum protection from dust and particulate contamination. It also includes an integral by-pass valve enabling the booster to start from atmosphere, eliminating the need for a vacuum pressure switch to ensure continuous operation regardless of vacuum level. The Stokes 61B series can be mounted separately or on the inlet of the backing pump to create a compact integrated package.

## Features & Benefits

- Mechanical shaft seal – improved life and serviceability
- Ringfeder® keyless gear locking system – stronger, faster timing
- Large shaft diameters – allowing improved performance at high pressures
- Belt drive or direct drive capability
- Vertical or horizontal gas flow

## Dimensions

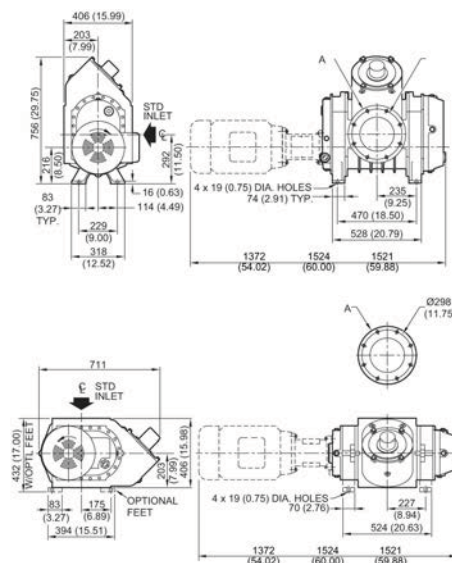

8" pipe flange connection 13 1/2" (343 mm) OD x 8" (203 mm) ID 8 x 3/4-10 NC-2B x 1 1/8" (29 mm) holes straddle both CL both flanges

## Technical Data

Displacement	
V belt (2750 rpm)	3375m <sup>3</sup> h <sup>-1</sup> / 2000ft <sup>3</sup> min <sup>-1</sup>
Direct drive (3000 rpm)	3685m <sup>3</sup> h <sup>-1</sup> / 2170ft <sup>3</sup> min <sup>-1</sup>
Direct drive (3600 rpm)	4420m <sup>3</sup> h <sup>-1</sup> / 2600ft <sup>3</sup> min <sup>-1</sup>
Inlet/outlet flanges	8" ASA/ANSI flange
Motor power E /Asia	18.5kW
Motor power S TEFC	25 hp
By-pass available	Yes
Cooling water	7.6-11.4l min <sup>-1</sup> / 2-3gal min <sup>-1</sup>
Oil capacity (horizontal flow)	1.9 litre / 4.1gal
Oil capacity (vertical flow)	4.1 litre / 8.8gal
Max temp rise	135°C / 275°F
Max discharge temp	191°C / 375°F
Weight bare shaft	284kg / 625lbs
Weight TEFC direct drive	538kg / 1185lbs

## Ordering Information

Product description	Order no.
61B 5HR CE 18.5kW, 230/400V, 3-ph, 50Hz @ 3000rpm	90061B5HR601
61B 5HR CE 18.5kW, 200-220/380V, 3-ph, 50/60Hz @ 3000/3600rpm	90061B5HR602
61B 5H25, 25hp, 230/460V, 3-ph, 60Hz @ 3600rpm	90061B5H25
61B 5HR (Bare Shaft) Horizontal flow	90061B5HR101
61B 5V25, 25hp, 230/460V, 3-ph, 60Hz @ 3600rpm	90061B5V25
61B 5VR (Bare shaft) Vertical flow	90061B5VR101
61B 5VR CE 18.5kW, 230/400V, 3-ph, 50Hz @ 3000rpm	90061B5VR601
61B 5VR CE 18.5kW, 200-220/380V, 3-ph, 50/60Hz @ 3000/3600rpm	90061B5VR602
Accessories Spares	Order no.
Replacement 6" booster Mseal - seal kit	607552001
Replacement 6" booster - maintenance kit	607552002
Process isolation seal kit	607552004







# Stokes 622 Series Process Isolation Boosters



Stokes 6" series process isolation boosters are designed to be used in conjunction with rotary-piston, dry vacuum, rotary vane and liquid ring pumps to increase pumping speed at working pressures and shorten pump down time significantly. They incorporate five mechanical seals for optimum protection from dust and particulate contamination and can be mounted separately or on the inlet of the backing pump to create a compact integrated package.

Featuring an extra large diameter shaft, the Stokes 6" series has the capability for use with higher powered motors in addition to ensuring a uniquely rugged and durable mechanical booster.

## Features & Benefits

- Mechanical shaft seal – improved life and serviceability
- Ringfeder® keyless gear locking system – stronger, faster timing
- Large shaft diameters – allowing improved performance at high pressures
- Belt drive or direct drive capability
- Vertical or horizontal gas flow

## Technical Data

Displacement	
V belt (2750 rpm)	5100m <sup>3</sup> h <sup>-1</sup> / 3000ft <sup>3</sup> min <sup>-1</sup>
Direct drive (3000 rpm)	5525m <sup>3</sup> h <sup>-1</sup> / 2350ft <sup>3</sup> min <sup>-1</sup>
Direct drive (3600 rpm)	6630m <sup>3</sup> h <sup>-1</sup> / 3900ft <sup>3</sup> min <sup>-1</sup>
Inlet/outlet flanges	8" ASA/ANSI flange
Motor power E /Asia	18.5kW
Motor power S TEFC	25hp
Cooling water	7.6-11.4l min <sup>-1</sup> / 2-3gal min <sup>-1</sup>
Oil capacity (horizontal flow)	1.9 litre / 4.1gal
Oil capacity (vertical flow)	4.1 litre / 8.8gal
Max pressure differential	333mbar / 250Torr
Max temp rise	121°C / 250°F
Max discharge temp	177°C / 350°F
Weight bare shaft	335kg / 740lbs
Weight TEFC direct drive	625kg / 1370lbs

## Dimensions

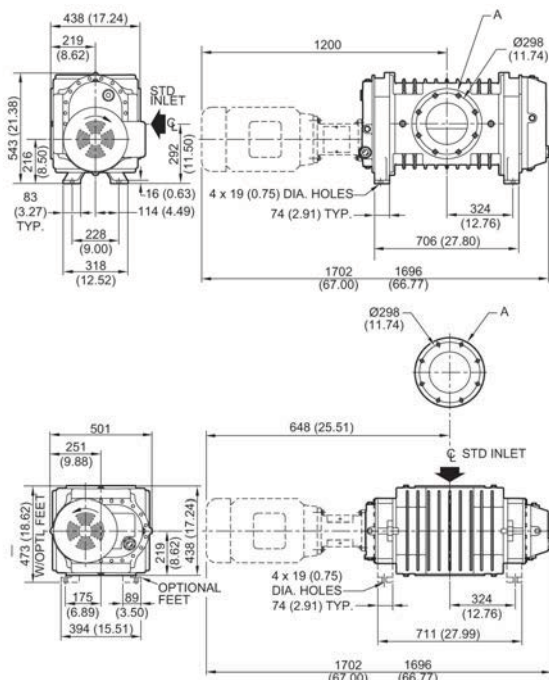

8" pipe flange connection 13 1/2" (343 mm) OD x 8" (203 mm) ID 8 x 3/4-10 NC-2B x 1 1/8" (29 mm) holes straddle both CL both flanges

## Ordering Information

Product description	Order no.
622 5HR CE 18.5kW, 230/400V, 3-ph, 50Hz @ 3000rpm	9006225HR601
622 5HR CE 18.5kW, 200-220/380V, 3-ph, 50/60Hz @ 3000/3600rpm	9006225HR602
622 5H25, 25hp, 230/460V, 3-ph, 60Hz @ 3600rpm	9006225H25
622 5HR (Bare shaft) Horizontal flow	9006225HR101
622 5V25, 25hp, 230/460V, 3-ph, 60Hz @ 3600rpm	9006225V25
622 5VR (Bare shaft) Vertical flow	9006225VR101
622 5VR CE 18.5kW, 230/400V, 3-ph, 50Hz @ 3000rpm	9006225VR601
622 5VR CE 18.5kW, 200-220/380V, 3-ph, 50/60Hz @ 3000/3600rpm	9006225VR602
Accessories Spares	Order no.
Replacement 6" booster Mseal - seal kit	607552001
Replacement 6" booster - maintenance kit	607552002